

INDUCTIVE CURRENT SENSOR BASED ON NANOCRYSTALLINE ALLOYS

*Euler C.T. Macedo¹, José G.A. Lira¹, Edson G. Costa¹, RAIMUNDO C. S. FREIRE¹, Benedito A. Luciano¹,
Marcelo J. A. Maia²*

¹ Centro de Engenharia Elétrica e Informática, Universidade Federal de Campina Grande – UFCG, Campina Grande, Brazil, euler.macedo@ee.ufcg.edu.br.

² Companhia Hidroelétrica do São Francisco – CHESF, Recife, Brazil, mjamaia@chesf.gov.br.

Abstract – In this paper are described the design and application of an inductive magnetic sensor based on nanocrystalline alloys. The sensor is adjusted for measurement and monitoring of currents with intensities from some microamperes to miliamperes. Its functional behaviour, performance and a specific application are described. One of the biggest advantages of this current sensor is its non-invasive characteristic, it means, is not required any direct contact with the circuit that is being monitored. It becomes appropriated for diverse applications where this requirement is necessary. An example of this sensor application is the metal oxide surge arresters leakage current monitoring.

Keywords: Current Sensor, Nanocrystalline Alloys, Magnetic Permeability, ZnO Surge Arresters.

1. INTRODUCTION

The ferromagnetic nanocrystalline alloys are, in general, magnetically soft materials; it means, possess high permeability μ , low coercivity H_C and small hysteresis loss, when compared with other conventional ferromagnetic alloys. This type of material is composed of a physical structure of nanocrystals with 10 nanometers of diameter, also, possess a constant magnetic permeability on a wide amplitude scale of the applied field. One another advantage of the nanocrystalline alloys is its superior induction saturation when compared with others conventional soft magnetic alloys, allowing a significant reduction of the core dimensions,[1] Such properties permit the design of current transformers appropriated for low intensity signals monitoring using nanocrystalline alloys.

In addition of the high permeability values, the alloys electric resistivity does not suffer a big variation with the temperature. Its high magnetic permeability facilitates the core magnetization process, requiring a relatively small magnetization current of the primary circuit, this characteristic allow the use of this material in current transforms applied to measurements with the motivation to reduce the turns ratio and phase errors when compared with the utilization of classic ferromagnetic materials generally used in commercial current transformers [2].

Considering the low leakage current intensity of the ZnO surge arrester, it was developed a toroidal inductive current sensor with magnetic permeability μ and high sensibility and linearity. However, it's necessary to observe the operation limits in the hysteresis and saturation curves with the purpose to avoid non-linearity problems. In Figure 1 is presented the operation region necessary to obtain a linear ratio between the voltage V in the current-voltage converter output and the leakage current I_T in the current sensor operation.

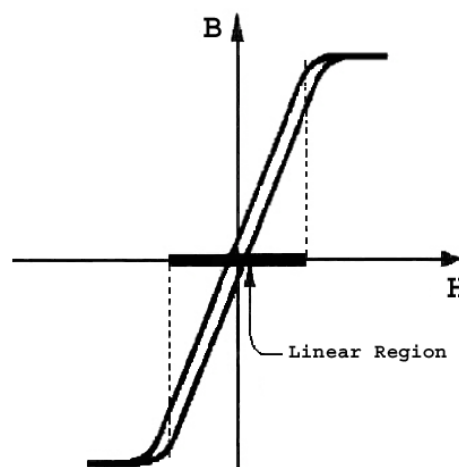

Fig. 1. Linear region of the magnetization curve.

One of the motivation for this research is the utilization of this current sensor in the ZnO surge arresters, because they lead a small leakage current when they are submitted to the nominal operation voltage. The total leakage current amplitude increase with the time, and this current it's one of the parameters used to monitoring the surge arrester degradation level. The ZnO surge arrester leakage current can be divided in two components: resistive and capacitive. The third harmonic component of the resistive current is the most sensible parameter used in the monitoring of the surge arrester degradation level. Consequently the sensor must have a high linearity, sensibility and resolution degree to allow an accurate diagnostic of the ZnO surge arrester degradation.

2. FUNCTIONAL DESCRIPTION

The basic principle of the magnetic current sensor for the acquisition of the ZnO leakage current is based on obtaining a voltage that is proportional to the current intensity that is necessary to acquire[4,5]. For such, is necessary to capture the magnetic field intensity H generated by the leakage current I_T . In normal operation, the surge arresters are energized in its top and connected to the ground in its base, the sensor should be installed in its ground cable. As presented in the Fig. 2.

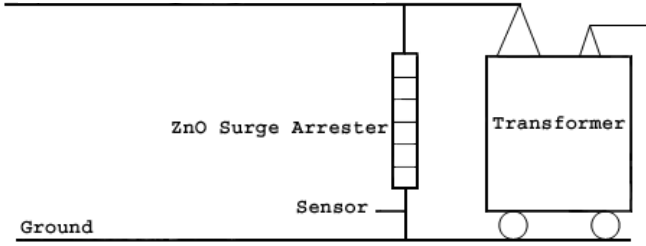

Fig. 2. Schematic installation of a ZnO surge arrester.

For the capture of the generated magnetic flux around the core, as presented in Fig. 3, was used soft magnetic material with high magnetic permeability and toroidal geometric format, with the intention of cause the flux confinement in a closed magnetic circuit.

The functional diagram presented in Fig. 3 illustrates the process used in the conversion of the leakage current value in a proportional equivalent tension. In the figure it is possible to observe that the total leakage current I_T that circulates in the ground cable, induces in the toroidal nucleus a proportional tension of the flux generated in its nucleus. Thus, if the nucleus material have a large value of magnetic permeability, it's possible to obtain a significant voltage value in the current sensor circuit output. The Ampère's Law establishes that the line integral of H in any closed loop path passage is accurately equal to the current enclosed in the loop, in agreement with (1).

$$\oint \vec{H} \cdot d\vec{l} = H 2\pi r = I_T \quad (1)$$

Equations (2) and (3) show that the voltage V_s is proportional to the time derivative of the magnetic flux and consequently to the time derivative of the leakage current I_T , requiring the use of an integrator, as presented in Fig. 3.

In (3), "A" represents the core material transversal area and μ is the permeability of the core magnetic material.

$$V_s = N_2 \frac{d\phi}{dt} \quad (2)$$

$$\frac{d\phi}{dt} = A \frac{dB}{dt} = \mu A \frac{dH}{dt} \quad (3)$$

Applying the Ampère's Law,

$$H = \frac{N_1 I_T}{l} \quad (4)$$

Deriving (4) it is obtained (5)

$$\frac{dH}{dt} = \frac{N_1}{l} \frac{dI_T}{dt} \quad (5)$$

The result of substituting (5) in (3) is (6), that presents the dependence of the magnetic flux with the current I_T .

$$\frac{d\phi}{dt} = \mu A \frac{N_1}{l} \frac{dI_T}{dt} \quad (6)$$

The circuit physical implementation is composed by the sensor toroidal core followed for a differential amplifier and an integrator, as shown in Fig. 3.

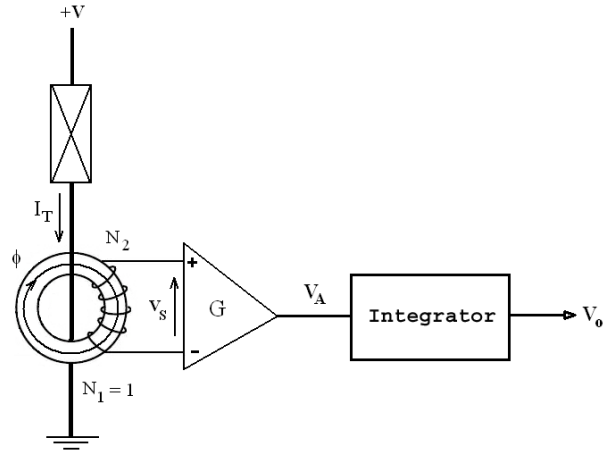

Fig. 3. Schematic diagram of the current sensor element.

2.1. Results

In the implementation of the metal oxide surge arresters leakage current measurer, it was used a toroidal core based on nanocrystalline magnetic alloy (FeSiBNbCu). In practice, most measurements have been made on a small toroid, typically 25/40 mm in inner/outer diameter and 15 mm in height. The core was submitted to a magnetization current in the primary circuit varying from 100 μ A to 10 mA.

An experimental configuration was implemented in laboratory, as shown in Fig. 4, with the objective to compare the acquired current waveform using the proposed current sensor and the current waveform measured in a knew resistance R of 1 k Ω . The two signals had been acquired, simultaneously, in two oscilloscope channels. In Fig. 5, 6 and 7, the superior signal waveform represent the voltage measured on the resistance R , and the inferior waveform represent the output voltage of the current-voltage sensor corresponding to the current sensor output.

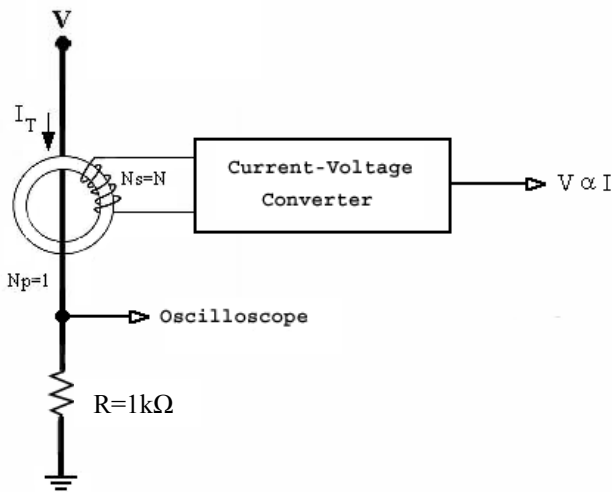

Fig. 4. Experimental tests configuration.

The first experimental step was to apply a triangular waveform of 60 Hz, 1V of peak between the terminals V and the ground, as shown in Fig. 4. The sensor was calibrated in a manner to supply 1 V in the sensor circuit output for each mA that circulates in the primary winding. The objective was to observe the linearity degree in the measurement for a linear variation increase and decrease of the current, and in the sequence, verify the sensor response in relation with the signal harmonic components, the result can be observed in Fig. 5.

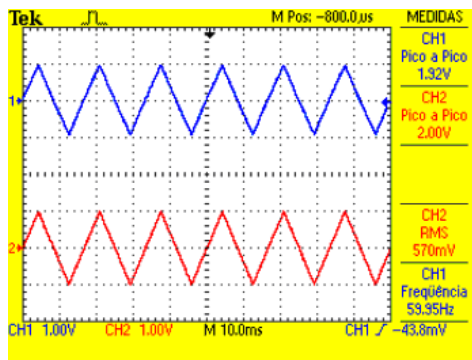

Fig. 5. Applied (upper) and acquired (below) triangular waveform.

For evaluation of the sensor response for rapid current transitions and to maintain the desired sensitivity and linearity, it was applied to the core primary winding a Sinc(t) and Pulse(t) magnetization current signals as illustrated in Fig. 6 and 7.

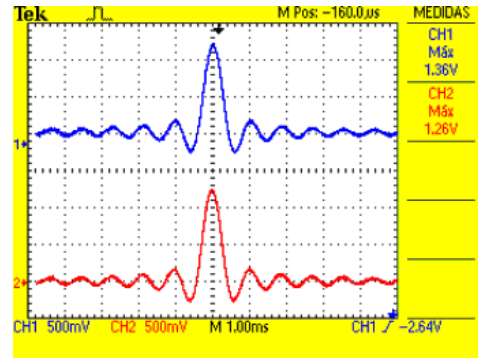

Fig. 6. Applied (upper) and acquired (red) Sinc waveform.

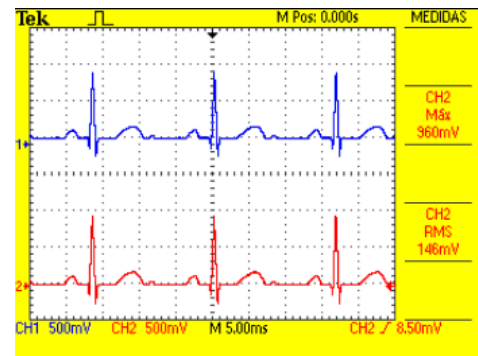

Fig. 7. Applied (upper) and acquired (below) pulse waveform.

2.2. Application

The developed magnetic current sensor was used, in a particular application, for the measurement of the total leakage current that circulates in ZnO surge arresters. An example of the ZnO surge arrester installation in a 230 kV electrical substation is presented in Fig. 8.

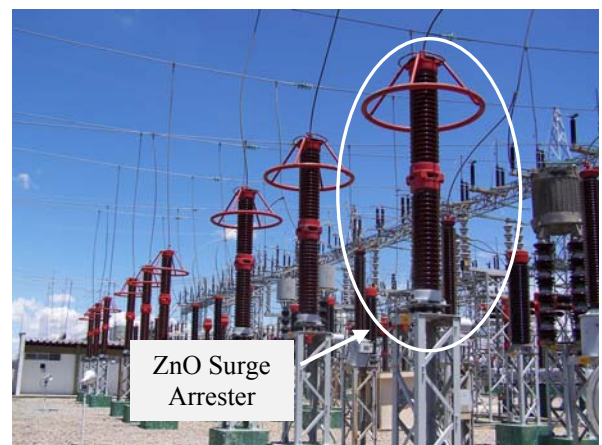

Fig. 8. Example of the ZnO Surge Arrester installation in a 230 kV electrical substation, CGII – CHESF.

Before the current sensor installation in the 230 kV electrical substation, some experimental essays were performed in laboratory, a voltage of 36 kV was applied in some surge arresters. The Fig. 9 and 10 shows the results of the total leakage current measurements in distinct conditions of functioning: the first one in good condition and the second with defect, presenting a high leakage current value.

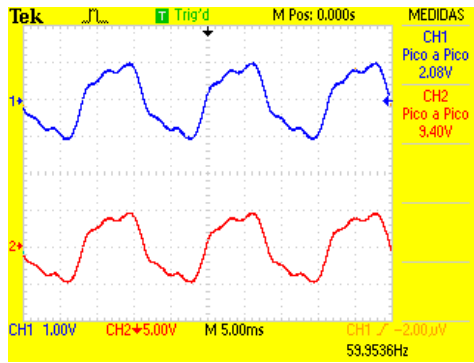

Fig. 9. ZnO surge arrester leakage when applied 36kV, this surge arrester is in good condition.

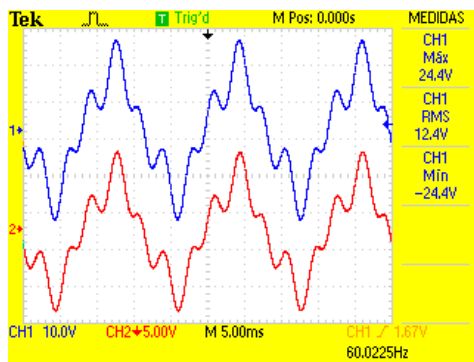

Fig. 10. ZnO surge arrester leakage when applied 36kV, this surge arrester is damaged.

In all the implemented experimental arrangements, the applied waveforms signals measured on a resistance R (upper curve) of 1 k Ω and those measured with the proposed sensor (bellow curve) presented a high similarity degree.

After perform the measurements in the high voltage laboratory using a voltage of 36 kV, a leakage current measurement was performed in a 230 kV electrical substation, one of the obtained results is presented in Fig. 11.

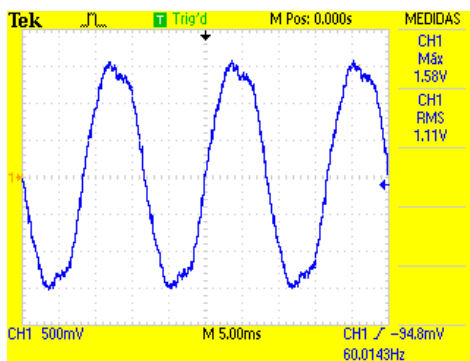

Fig.11. ZnO surge arrester leakage when applied 230kV.

3. CONCLUSIONS

This paper evidences a new application for the use of magnetic core based on nanocrystalline alloys, used for sensors and monitoring currents with low intensities. It's application is appropriated to currents of some microamperes to milliamperes.

The expectations of the developed sensor were fully attended in relation with its design and implementation. During the research the sensor was submitted to innumerable tests for verification of its trustworthiness and results repeatability. In all the implemented experimental arrangements, the applied signals waveforms measured on a knew resistance and the measured with the proposed current sensor presented a high similarity degree.

Although the research has been developed with several core of diverse compositions of nanocrystalline alloys, for example, the $Fe_{73.5}Nb_3Cu_1Si_{13.5}B_9$, $Fe_{73.5}Nb_3Cu_1Si_{15.5}B_7$, in this paper is highlighted the results obtained using a manufactured toroidal core with composition (FeSiBNbCu), this soft magnetic material presented the highest measured relative permeability value ($\mu_r = 185707$).

The high permeability value of this material, associated with the high saturation induction, high linearity, low coercivity field, low magnetostriction and small hysteresis loss permit the utilization of this sort of magnetic material in design of low amplitude (microamperes) current sensors.

ACKNOWLEDGMENTS

The authors wish to thanks the National Council for Scientific and Technological Development- CNPQ, and the CHESF (P&D Project CT-I-92.2007.8690.00), for the support in the institutional research, and the Electrical Engineering and Informatics Center of the Campina Grande Federal University, for the support during the paper experimental tests.

REFERENCES

- [1] Lira, J. G. Assis, Luciano, B. A., Freire, R. C. S., Castro, W. B. Ligas amorfas e ligas nanocristalinas: aplicações em dispositivos eletroeletrônicos. Revista Eletricidade Moderna, Ano XXXIII, Num. 375, pg. 154-161, Junho, 2005.
- [2] Benedito A. Luciano, Raimundo C. S. Freire, José Gutembergue A. Lira, Glauco Fontgalland, e Walman B. de Castro. "Transformador de Corrente com Núcleo Toroidal de Liga Nanocristalina: Estudo analítico e computacional" IEEE IM2005, 6º Encuentro de Potencia, Instrumentación y Medidas, Uruguay, 2005.
- [3] Lira, J. G. A. Sistema de aquisição de dados para monitoramento e diagnóstico remoto das condições de pára-raios de óxido de zinco. 2007. Tese (Doutorado em Engenharia Elétrica), Centro de Engenharia Elétrica e Informática. Universidade Federal de Campina Grande, Campina Grande.
- [4] Gupta, T. K., "Application of zinc oxide surge varistors", J. Am. Ceram. Soc., vol. 73, n.7, p.1817-1840, 1990.
- [5] Lundquist, J. "New Method for measurement of the resistive leakage currents of metal-oxide surge arresters in service", IEEE Transacions on Power Delivery, Vol. 5, No. 4, November 1990.