

NASA/TP—1998-208415



Initialization, Conceptualization, and Application in the Generalized Fractional Calculus

Carl F. Lorenzo
Lewis Research Center, Cleveland, Ohio

Tom T. Hartley
University of Akron, Akron, Ohio

National Aeronautics and
Space Administration

Lewis Research Center

December 1998

Available from

NASA Center for Aerospace Information
7121 Standard Drive
Hanover, MD 21076
Price Code: A06

National Technical Information Service
5285 Port Royal Road
Springfield, VA 22100
Price Code: A06

TABLE OF CONTENTS

| | |
|---|----|
| 1. Introduction..... | 1 |
| 2. Motivation for Initialization..... | 4 |
| 3. Conceptualization | 6 |
| 3.1 Riemann-Liouville Differintegral..... | 6 |
| 3.1.1 Interpretation 1 | 6 |
| 3.1.2 Interpretation 2 | 8 |
| 3.2 Grünwald Differintegral | 9 |
| 3.2.1 Time Delay/Conveyor Interpretation | 9 |
| 3.2.2 Geometric Interpretation of Fractional Differintegral | 14 |
| 3.2.3 Geometric Interpretation | 18 |
| 4. Definitions for the Generalized Calculus With Initialization Functions..... | 18 |
| 4.1 Riemann-Liouville Basis..... | 18 |
| 4.1.1 Simple Example | 22 |
| 4.2 Grünwald Basis | 24 |
| 4.3 Notation | 26 |
| 5. Criteria for a Generalized (Fractional) Calculus | 26 |
| 5.1 Ross' Criteria..... | 26 |
| 5.2 Criterion 2: Backward Compatibility | 28 |
| 5.3 Criterion 3: Zero Property | 29 |
| 5.4 Criterion 4: Linearity | 31 |
| 5.5 Criterion 5: Composition..... | 33 |
| 5.5.1 Part 1, Fractional Integration..... | 34 |
| 5.5.2 Part 2, Mixed Generalized Integration and Integer Order Differentiation | 36 |
| 5.5.3 Part 3, Fractional Differentiation..... | 42 |
| 5.5.4 Part 4, Mixed Integration and Differentiation | 44 |
| 5.5.5 Comments on Criteria | 44 |
| 6. Laplace Transforms of Generalized Differintegrals | 46 |
| 6.1 Preliminaries..... | 46 |
| 6.2 Laplace Transforms of Fractional Integrals..... | 47 |
| 6.2.1 Integer Order Decomposition of Fractional Integral | 48 |
| 6.2.2 Fractional Order Decomposition of Fractional Integral | 51 |
| 6.3 Laplace Transforms of Fractional Derivatives | 53 |
| 6.3.1 Integer Order Decompositions of the Fractional Derivative | 54 |
| 6.3.2 Fractional Order Decompositions of the Fractional Derivative | 57 |
| 6.4 Effect of Terminal Charging on Laplace Transforms | 58 |
| 6.5 Effect of Starting Point..... | 59 |
| 6.5.1 Fractional Integral | 59 |
| 6.5.2 Fractional Derivative..... | 60 |

| | | |
|-------|--|----|
| 6.6 | Laplace Transform of the Initialization Function..... | 60 |
| 6.6.1 | Fractional Integral | 60 |
| 6.6.2 | Fractional Derivative | 61 |
| 6.7 | Summary—Comments an Laplace Transforms of Differintegrals..... | 61 |
| 7. | Applications | 63 |
| 7.1 | Preliminaries..... | 63 |
| 7.1.1 | Half Order Element | 64 |
| 7.1.2 | Zero Order Element | 65 |
| 7.1.3 | Operational Amplifier | 65 |
| 7.2 | Integrators..... | 66 |
| 7.2.1 | Classical (Integer Order Calculus) Integrator..... | 66 |
| 7.2.2 | Generalized (Calculus) Integrator | 67 |
| 7.3 | Differentiators..... | 69 |
| 7.3.1 | Classical (Integer Order Calculus) Differentiator | 69 |
| 7.3.2 | Generalized (Calculus) Differentiator | 70 |
| 7.4 | Zero Order Operators (ZOOs)..... | 71 |
| 7.4.1 | Classical (Calculus) ZOO..... | 71 |
| 7.4.2 | Generalized (Calculus) ZOOs | 71 |
| 7.5 | Half Order Circuits | 73 |
| 7.5.1 | Semi-Integrator..... | 73 |
| 7.5.2 | Semi-Differentiator..... | 74 |
| 7.6 | Combination Circuits | 75 |
| 7.6.1 | Tandem Semi-Integrators | 75 |
| 7.6.2 | Inverse Operations..... | 76 |
| 7.7 | Dynamic Thermocouple | 77 |
| 7.8 | Electrolytic Cell..... | 78 |
| 7.8.1 | Charging Phase..... | 79 |
| 7.8.2 | Initialization Function | 82 |
| 7.8.3 | Load Drawing Phase..... | 83 |
| 7.9 | Material Creep | 84 |
| 7.9.1 | Creep Strain..... | 84 |
| 7.9.2 | Creep Initialization | 85 |
| 7.9.3 | Relaxation Function | 86 |
| 7.10 | Fractional Order Tracking Filter | 86 |
| 7.11 | Viscoelastic Damped Vibration..... | 88 |
| 8. | Variable Structure (Order) Differintegral | 91 |
| 8.1 | Variable Order Integration | 91 |
| 8.1.1 | Research Issues..... | 91 |
| 8.1.2 | Motivation | 91 |
| 8.1.3 | Analysis | 92 |
| 8.1.4 | Criteria..... | 92 |
| 8.1.5 | Laplace Transform..... | 95 |
| 8.2 | Variable Order Differentiation | 96 |

| | |
|--|-----|
| 9. Summary | 97 |
| Appendix A. Application of Dirichlet's Formula | 99 |
| Appendix B. Laplace Transform Of Multiple Integer Order Integrals | 100 |
| Appendix C. Variable Structure (Order) Differintegral Grünwald Basis | 101 |
| References..... | 103 |

INITIALIZATION, CONCEPTUALIZATION, AND APPLICATION IN THE GENERALIZED FRACTIONAL CALCULUS

Carl F. Lorenzo
National Aeronautics and Space Administration
Lewis Research Center
Cleveland, Ohio

Tom T. Hartley
University of Akron
Department of Electrical Engineering
Akron, Ohio

Abstract

This paper provides a formalized basis for initialization in the fractional calculus. The intent is to make the fractional calculus readily accessible to engineering and the sciences. A modified set of definitions for the fractional calculus is provided which formally include the effects of initialization. Conceptualizations of fractional derivatives and integrals are shown. Physical examples of the basic elements from electronics are presented along with examples from dynamics, material science, viscoelasticity, filtering, instrumentation, and electrochemistry to indicate the broad application of the theory and to demonstrate the use of the mathematics. The fundamental criteria for a generalized calculus established by Ross (1974) are shown to hold for the generalized fractional calculus under appropriate conditions. A new generalized form for the Laplace transform of the generalized differintegral is derived. The concept of a variable structure (order) differintegral is presented along with initial efforts toward meaningful definitions.

1. Introduction

The development of fractional calculus is nearly as old as the development of the actual calculus. Discussion as early as 1695 by Leibnitz, and later by others, indicates an interest in integrals and derivatives of fractional (non-integer) order. Excellent historical summaries of the development of the fractional calculus can be found in Oldham and Spanier (1974) and Miller and Ross (1993). Although much attention has been directed toward the development of the

fractional calculus, this has largely been in the domain of the mathematician and the applied mathematician with relatively little work being done in the engineering and applied sciences.

Strong motivation exists for the study, development, and generalization of the fractional calculus. This may be readily validated by looking ahead to the Applications section of this paper where a broad range of problems are described and solved using a generalization of the fractional calculus. The unifying concepts and notation of the fractional calculus provide a significant benefit that greatly simplifies the solution of certain partial differential equations (distributed systems). Perhaps the strongest motivation to develop the fractional calculus is the belief that a wide variety of physical problems and engineering disciplines that have resisted compact (and first principles) description and solution when using the integer order calculus will yield to the methods of the fractional calculus. These include such areas as heat transfer, boundary layer behavior, and many problems where the major recourse has been to probabilistic methods.

This paper looks at some of the primary problems with the fractional calculus, as it is now embodied, and attempts to rectify some of these with a modified (alternative) embodiment. The basic approach that has been taken in this work has been to make the defined mathematics as maximally applicable to the problems of engineering and science as possible. To this end, basic distributed dynamic systems have been developed for use as reference fractional systems. The authors have tried to maintain maximal generality in these reference systems (Hartley and Lorenzo (1998)) as required for the new definitions.

The problems that the authors perceive to bar widespread application of the fractional calculus in the engineering sciences will now be discussed. The operative basis definition for this section will be the contemporary, Riemann-Liouville definition, which is that integration of arbitrary order is given by

$${}_c D_t^{-\nu} f(t) = \frac{d^{-\nu}}{[d(t-c)]^{-\nu}} f(t) = \frac{1}{\Gamma(\nu)} \int_c^t (t-\tau)^{\nu-1} f(\tau) d\tau, \quad (1.1)$$

where $-\infty \leq c < t$ and $\nu \geq 0$ and $\Gamma(\nu)$ is the gamma function. The notation here is as follows: the left term is that of Ross (1974) and, originally, Davis (1936), and the middle term is that of Oldham and Spanier (1974). For simplicity in this paper ν is constrained to be a real number (or real variable). The reader is cautioned that the notation used later in the paper is the same as Ross but has a different (generalized) meaning, which is defined there.

Contemporary differentiation is defined as

$${}_c D_t^{\nu} f(t) = \frac{d^m}{dt^m} {}_c D_t^{-q} f(t), \quad (1.2)$$

where $\nu = m - q$ and $\nu \geq 0$ and m is an integer $> \nu$. For the reader new to the fractional calculus it should be noted that several other basis definitions have been forwarded by various authors. Reference to these may be found in the following excellent publications: Miller and Ross (1993),

Oldham and Spanier (1974), Samko et al. (1993), and elsewhere. It is further noted that equation (1.1) is a positive running (t increasing) integration since it is required that $t - \tau > 0$.

Alternatives are discussed in the literature that may be viewed as negative running integrations such as the Weyl definition for fractional integration (see for example, Miller and Ross (1993)).

One of the fundamental problems of contemporary fractional calculus, is the requirement that the function $f(t)$ and its derivatives be identically equal to zero for $t = c$ (i.e., the time of initialization) (Ross (1974)) or lacking this, to limit the functions handled to special classes (see for example, Miller and Ross, (1993)). This is needed to assure that composition (the index law) holds, that is, to assure that

$${}_c D_t^\alpha {}_c D_t^\nu f(t) = {}_c D_t^\nu {}_c D_t^\alpha f(t) = {}_c D_t^{\alpha+\nu} f(t). \quad (1.3)$$

It is difficult, in the engineering sciences, to always require that the functions and derivatives be zero at initialization. This fundamentally says that ***there can either be no initialization or composition is lost***. Thus, it is not in general true that

$$f - \frac{d^{-\alpha}}{dt^{-\alpha}} \frac{d^\alpha f}{dt^\alpha} = 0 \quad (1.4)$$

(see for example, Oldham and Spanier (1974), pp. 155 and 82-87).

Thus, when solving a fractional ordinary differential equation of the form

$$\frac{d^\alpha f}{dt^\alpha} = F, \quad (1.5)$$

additional terms must be added to equation (1.4)

$$f - \frac{d^{-\alpha}}{dt^{-\alpha}} \frac{d^\alpha f}{dt^\alpha} = C_1 t^{\alpha-1} + C_2 t^{\alpha-2} + \dots + C_m t^{\alpha-m}, \quad (1.6)$$

to achieve the most general solution

$$f = \frac{d^{-\alpha} F}{dt^{-\alpha}} + C_1 t^{\alpha-1} + C_2 t^{\alpha-2} + \dots + C_m t^{\alpha-m}. \quad (1.7)$$

The reader is referred to Oldham and Spanier (1974) for a detailed exposition in this area. The added terms are analogous to the effects of the constants of integration in the integer order calculus.

Both of the above issues are related to the inadequacy of the composition law. This inadequacy of the composition law, in fact, points to a problem with the fundamental definitions used as the basis of the fractional calculus.

Flowing from the above inadequacies, the Laplace transform of the fractional differintegral, currently (Oldham and Spanier (1974)) given as

$$L\left\{\frac{d^q f}{dt^q}\right\} = s^q L\{f\} - \sum_{k=0}^{n-1} s^k \frac{d^{q-l-k} f}{dt^{q-l-k}}(0), \quad (18)$$

is found to lack sufficient generality in the initialization term(s) for many applications.

The objective of this paper is to provide a formalized basis for the initialization of the fractional (generalized) calculus so that it may be readily accessible to the sciences and engineering. In particular, a set of definitions will be provided which formally (explicitly) include the initialization functions. Conceptualizations of fractional derivatives and integrals will be shown. Applications and physical examples of the basic elements (many drawn from electronics) will be presented along with examples from dynamics, material science, and more to indicate the broad application of the theory. Also, the fundamental criteria for a fractional or generalized calculus established by Ross (1974) will be investigated. Those criteria which apply to the proposed approach will be proven and rationale for compromising/generalizing those remaining will be given. The Laplace transform of the generalized differintegral will be derived. Finally, some physical conceptualizations will be given for fractional differintegration and some applications will be used to demonstrate the mathematics.

The authors have attempted to write to both the mathematics and the engineering/scientific fields. Thus, the engineering reader will find familiar block diagrams associated with the mathematics and, hopefully, the mathematician will find sufficient rigor in the proofs.

2. Motivation for Initialization

In real applications, it is usually the case that the problem to be solved is in some way isolated from the past. That is, it should not be necessary to retreat to $-\infty$ in time to start the analysis. Usually, the analyst desires to start the analysis (for instance, in the case of a system of ordinary differential equations (ODE's)) at some time, say t_0 , with knowledge (or assumption) of all values of the function and its derivatives. Specifically, $f(t_0), f'(t_0), f''(t_0), \dots, f^{(n)}(t_0)$, in the case of ODE's. In modern parlance, this collection of constants is called the system *state* and contains the effect of all the past history.

The desire to initialize fractional ordinary differential equations (FODE's) or a system of FODE's continues to exist in the fractional or generalized calculus domain. To understand the application of fractional calculus in terms of fractional or extraordinary differential equations, the

authors considered a system (Hartley and Lorenzo (1998)) which can be described as a semi-differential equation or semi-integral equation. Physically this system is the semi-infinite lossy line, which is described by a diffusion equation of the form

$$\frac{\partial v(x,t)}{\partial t} = \alpha \frac{\partial^2 v(x,t)}{\partial x^2}, i(x,t) = -\frac{1}{r} \frac{\partial v(x,t)}{\partial x}, v(0,t) = V_i(t), v(\infty,t) = 0, V(x,0) \text{ given.} \quad (2.1)$$

Here, v is the voltage, i is the current, $V_i(t)$ is a time-dependent input variable, and α is a constant, which is one over the product of resistance per unit length, r , and capacitance per unit length, c .

One way the behavior of the semi-infinite line can be described is in terms of its input behavior (impedance) at the open end of the line, that is, as a semi-differential equation. However, to practically use such an FODE to describe the behavior at the input, requires the addition of a function of time. In terms of the physics, this time function relates back to the initial voltage distribution (distributed initialization) on the semi-infinite lossy line. The details of this derivation are given in Hartley and Lorenzo (1998). The primary result for the voltage at the input of the lossy line is given by

$$V(0,s) = \frac{rI(0,s)}{\sqrt{\frac{s}{\alpha}}} + \frac{1}{\alpha\sqrt{\frac{s}{\alpha}}} \int_0^{\infty} e^{-\sqrt{\frac{s}{\alpha}}\lambda} V(\lambda,0) d\lambda, \quad (2.2)$$

where λ is a dummy variable of integration and s is the Laplace transform parameter.

Equation (2.2) was determined using a conventional iterated Laplace transform approach applied to the diffusion equation. However, an attraction of the fractional calculus is the ability to express the behavior of the line (a distributed system or mathematically partial differential equation) as part of the system of distributed equations using fractional ordinary differential equations (FODE's). Such a fractional (extra)ordinary differential equation for this application would be of the form

$$\frac{d^{1/2} v(t)}{dt^{1/2}} = r\sqrt{\alpha} i(t), \quad (2.3)$$

assuming $v(x,0) = 0$. To initialize this distributed system, a function of time, $\psi(t)$, must be added to account for the integral term in equation (2.2). Thus,

$$\frac{d^{1/2} v(t)}{dt^{1/2}} + \psi(t) = r\sqrt{\alpha} i(t). \quad (2.4)$$

The focus of interest is the integral term or $\psi(t)$ of equation (2.4). Clearly, one can add such terms in an ad hoc way to the FODE's which are being solved. However, it is the authors' opinion that a better approach is to formally include an initialization function, $\psi(t)$, in the definition of the fractional differintegrals. This is the approach that will be developed later in the

paper. Clearly, if the analyst is constrained that the initial function value and all of its derivatives are zero, the range of applicability for this entire class of problems (which will probably include, eventually, all distributed systems) will be greatly limited. It is the authors' contention that all fractional ordinary differintegral equations require initialization terms to be associated with each fractional differintegral term, in order to complete the description. Indeed it will be shown that some ordinary differential equations (i.e., integer order differintegrals) may require a $\psi(t)$ initialization. This requirement is a generalization to the requirement of a set of initialization constants (the state) in ordinary differential equations. Fundamentally it is the information required to start the integration process of the differential equations while properly accounting for the effects of the past. Before presenting the formal definition of this generalized calculus, it is useful to examine some interpretations of fractional differintegrals.

3. Conceptualization

The interpretations of fractional differintegrals presented in this section are based on the contemporary definitions see, Ross (1974) and Oldham and Spanier (1974). The extensions of these interpretations to the definitions that follow in this paper will be obvious.

3.1 Riemann-Liouville Differintegral

3.1.1 Interpretation 1

The Riemann-Liouville definition for the fractional integral is

$$\frac{d^{-q}}{[d(t-a)]^{-q}} f(t) = \frac{1}{\Gamma(q)} \int_a^t (t-\tau)^{q-1} f(\tau) d\tau \quad q \geq 0. \quad (3.1.1.1)$$

This definition is extended to fractional derivatives by simply differentiating; thus

$$\frac{d^{m-q} f}{[d(t-a)]^{m-q}} \equiv \frac{1}{\Gamma(q)} \frac{d^m}{dt^m} \int_a^t (t-\tau)^{q-1} f(\tau) d\tau \quad q \geq 0, \quad m > q, \quad (3.1.1.2)$$

and m is an integer.

A graphical display of the semi-derivative and semi-integral of $f(t) = \cos(0.4\pi t)$ is presented in figure 3-1-1. For this case $a = 0$, and equation (3.1.1.1) becomes

$$\frac{d^{-1/2} f(t)}{[d(t)]^{1/2}} = \frac{1}{\Gamma\left(\frac{1}{2}\right)} \int_0^t \frac{\cos(0.4\pi\tau)}{(t-\tau)^{1/2}} d\tau. \quad (3.1.1.3)$$

Plate (a) of figure 3-1-1 shows the fixed part of the integrand; this is unchanged for all semi-integrals regardless of $f(t)$, t is a parameter on this plot.

Plate (b) is the time function to be semi-integrated, plotted as a function of τ . The complete integrands, which are the product of the functions in plates (a) and (b) are as shown in plate (c); again various values of t are shown as parameters. The semi-integral, plate (d), is the locus of the values of the integrals of all parametric values of t as shown in plate (c), (and more). The semi-derivative is obtained simply by differentiating the half integral, and is shown in plate (e).

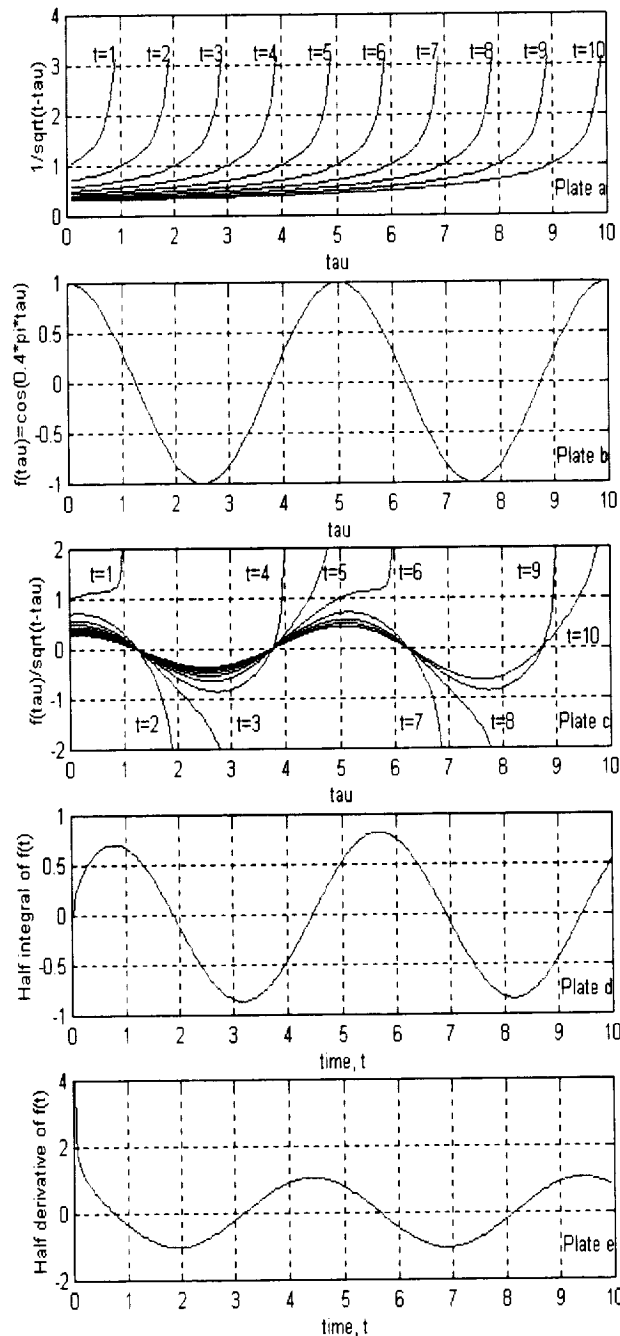

Figure 3-1-1.—Interpretation of fractional differintegrals based on Reimann-Liouville definition.

3.1.2 Interpretation 2

The Riemann-Liouville integral can also be viewed as a convolution integral as

$$\frac{d^{-q} f(t)}{[d(t-0)]^q} = f(t) * h(t) = f(t) * \left(\frac{1}{\Gamma(q)t^{-q+1}} \right) = \frac{1}{\Gamma(q)} \int_0^t \frac{f(\tau) d\tau}{(t-\tau)^{-q+1}} \quad q \geq 0. \quad (3.1.2.1)$$

In this instance both $f(t)$ and $h(t) = 1/\Gamma(q)t^{-q+1}$ are considered to be causal (i.e., no convolution response can be obtained before $f(t)$ is applied), and $*$ represents the convolution operation (see for example, Churchill (1958)). An excellent discussion of this interpretation of the convolution integral is given in Gabel and Roberts (1973). This viewpoint is reflected graphically in figure 3-1-2 where again $f(t) = \cos(0.4\pi t)$ and $q = 0.5$. Here, plate (a) shows $h(\tau)$ versus τ , the negative function $h(-\tau)$ is shown in plate (c), and $h(t-\tau)$ for $t = 5$ is plotted on plate (d). The function $f(\tau)$, to be fractionally integrated, is presented in plate (b). Plate (e) shows the full integrand, $h(t-\tau)f(\tau)$ for $t = 5.0$. Finally, the integral of this product becomes the $t = 5.0$ value of the fractional integral, plate (f).

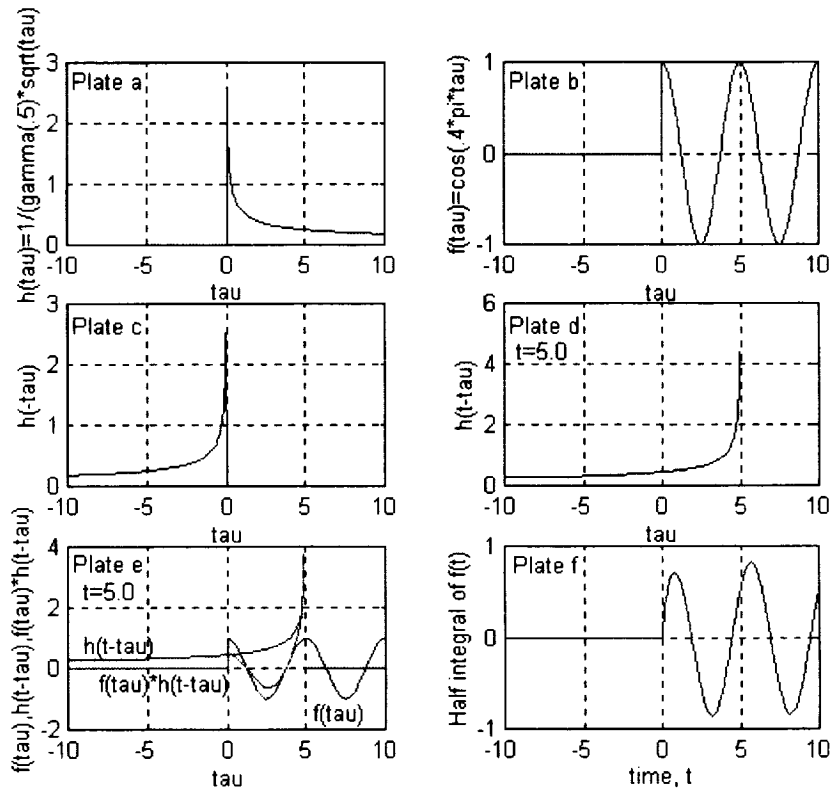

Figure 3-1-2.—Riemann-Liouville integral interpreted as a convolution integral.

3.2 Grünwald Differintegral

3.2.1 Time Delay /Conveyor Interpretation

Another, more physically based, interpretation of a fractional differintegral can be made based on the Grünwald definition. This definition, considered as the primary definition by Oldham and Spanier (1974), is given as

$$\left. \frac{d^q f(t)}{[d(t-a)]^q} \right|_{GRUN} \equiv \lim_{N \rightarrow \infty} \frac{\left(\frac{t-a}{N}\right)^{-q}}{\Gamma(-q)} \sum_{j=0}^{N-1} \frac{\Gamma(j-q)}{\Gamma(j+1)} f\left(t - j\left(\frac{t-a}{N}\right)\right), \quad (3.2.1.1)$$

where $q < 0$ indicates fractional integration and $q > 0$ indicates fractional differentiation. Understanding of this interpretation will be increased by studying a particular case. Consider the much simplified approximation to equation (3.2.1.1) for $q = 1/2$, $N = 4$. Then from equation (3.2.1.1)

$$\frac{d^{1/2} f(t)}{[d(t-a)]^{1/2}} \equiv \frac{\left(\frac{t-a}{4}\right)^{-1/2}}{\Gamma\left(-\frac{1}{2}\right)} \left\{ \begin{array}{l} \frac{\Gamma(-1/2)}{\Gamma(1)} f(t) + \\ \frac{\Gamma(1/2)}{\Gamma(2)} f\left(t - \left(\frac{t-a}{4}\right)\right) + \\ \frac{\Gamma(3/2)}{\Gamma(3)} f\left(t - 2\left(\frac{t-a}{4}\right)\right) + \\ \frac{\Gamma(5/2)}{\Gamma(4)} f\left(t - 3\left(\frac{t-a}{4}\right)\right) \end{array} \right\}. \quad (3.2.1.2)$$

Each of the function evaluations is a time delayed evaluation of $f(t)$. Further, each of these time delayed functions is multiplied by a constant, which is $\Gamma(j-q)/\Gamma(-q)\Gamma(j+1)$ and also multiplied by $\left(\frac{t-a}{4}\right)^{-1/2}$.

In diagram form, it is seen that the base function $f(t)$ is evaluated unshifted and progressively time-shifted in increments of $((t-a)/N)$ for $(N-1)$ many times. In this case the diagram is as shown in figure 3-2-1. Thus, the semi-derivative of $f(t)$ is seen to be a summation of progressively delayed evaluations of $f(t)$ multiplied by progressively decreasing constants and finally multiplied by $\sigma^{-1/2}$. Now $N = 4$ is a very crude approximation to the semi-derivative and equation (3.2.1.1) calls for the limit as N approaches infinity. It is instructive to allow N to approach infinity.

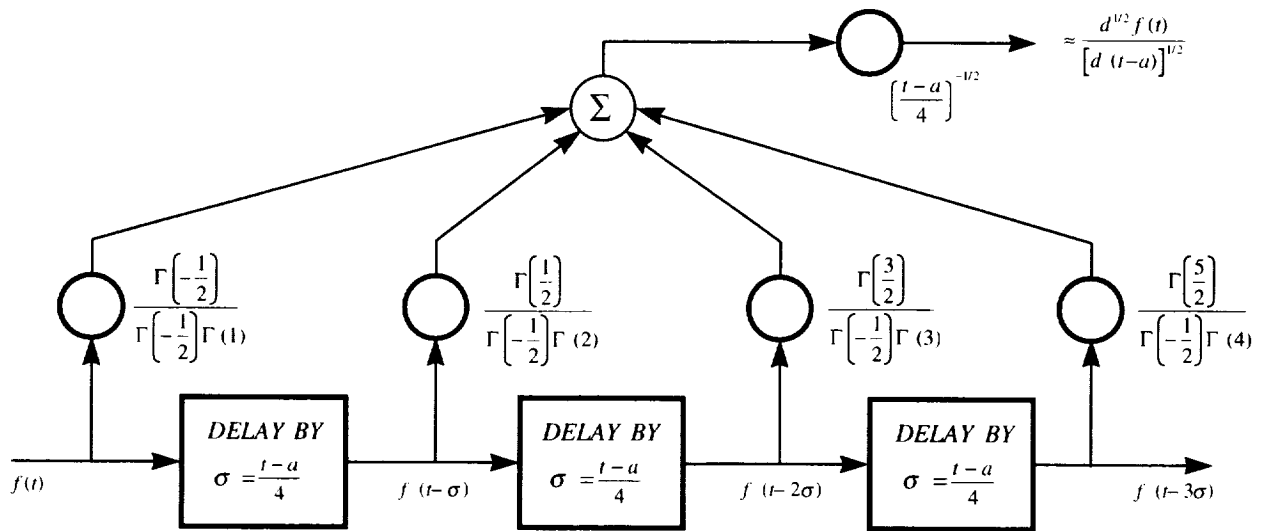

Figure 3-2-1.—Time delay approximation to semi-derivative.

The following case is considered, $q = 1/2$, $N = 10,000$. Then equation (3.2.1.1) is much more closely approximated by

$$\frac{d^{1/2} f(t)}{[d(t-a)]^{1/2}} \cong \frac{\left(\frac{t-a}{10000}\right)^{-1/2}}{\Gamma\left(-\frac{1}{2}\right)} \left\{ \begin{array}{l} \frac{\Gamma(-1/2)}{\Gamma(1)} f(t) + \\ \frac{\Gamma(1/2)}{\Gamma(2)} f\left(t - \left(\frac{t-a}{10000}\right)\right) + \\ \frac{\Gamma(3/2)}{\Gamma(3)} f\left(t - 2\left(\frac{t-a}{10000}\right)\right) + \\ \vdots \\ \frac{\Gamma(j-1/2)}{\Gamma(j+1)} f\left(t - j\left(\frac{t-a}{10000}\right)\right) + \\ \vdots \\ \frac{\Gamma(9997.5)}{\Gamma(9999)} f\left(t - 9998\left(\frac{t-a}{10000}\right)\right) + \\ \frac{\Gamma(9998.5)}{\Gamma(10000)} f\left(t - 9999\left(\frac{t-a}{10000}\right)\right) \end{array} \right\}. \quad (3.2.1.3)$$

It can be seen by comparison with the previous approximation, that the gamma function based coefficients are the same for the first N terms. The time shift factor (incremental delay) $((t-a)/N)$ is of course very much smaller and indeed approaches zero as N goes to infinity.

A diagram for this approximation is given in figure 3-2-2. The diagrams of figures 3-2-1 and 3-2-2 are easily associated to a physical interpretation by considering the behavior of a conveyor figure 3-2-3(a). The analogy considers a conveyor with some material (e.g., sand) dropped from a hopper to the conveyor surface. The height of the sand on the conveyor is related to $f(t)$. Height sensors are evenly spaced such that the time for the conveyor to move the distance between two sensors is $\sigma = (t - a) / N$ when the conveyor moves at speed $V(t)$. The figure shows a time function $f(t)$ and its shifted counterparts $f(t - \sigma), f(t - 2\sigma), \dots, f(t - (N - 1)\sigma)$. The outputs of the height sensors are multiplied by appropriate gamma function coefficients as in figures 3-2-1 and 3-2-2 and summed, etc. The result of the summation then is the fractional differintegral. This analogy evenly distributes N sensors between $\tau = 0$ and $\tau = t$, therefore the spatial spacing changes as t increases.

An alternate conveyor analogy allows a fixed spatial distribution if in the Grünwald equation (3.2.1.1) the substitution $N = (t - a) / \Delta T$ is made. In the limit as $\Delta T \rightarrow 0$, ΔT is always chosen so that N is an integer, then this gives

$${}_a D_t^q f(t) = \lim_{\Delta T \rightarrow 0} \frac{(\Delta T)^{-q}}{\Gamma(-q)} \sum_{j=0}^{N-1} \frac{\Gamma(j-q)}{\Gamma(j+1)} f(t - j(\Delta T)). \quad (3.2.1.4)$$

This situation is indicated in figure 3-2-3(b). Assuming no initialization, the sensors at $f(t - m\sigma)$ at time $t = 0$ will show no output. It is clear that preloading the conveyor to the right of the zero point is the same as initializing the differintegral and is the same as extending the function backward in time.

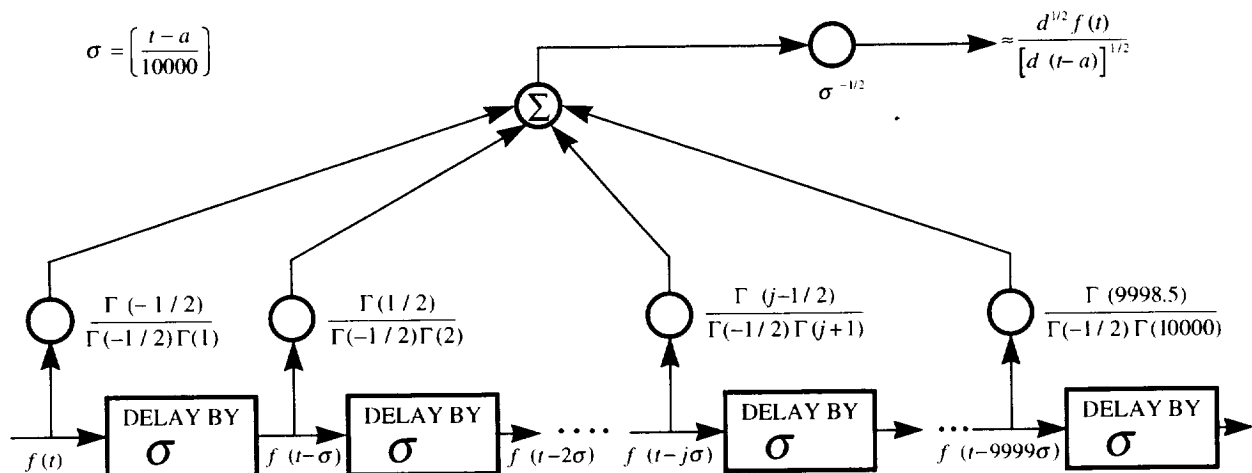

Figure 3-2-2.—High order approximation of the semi-derivative.

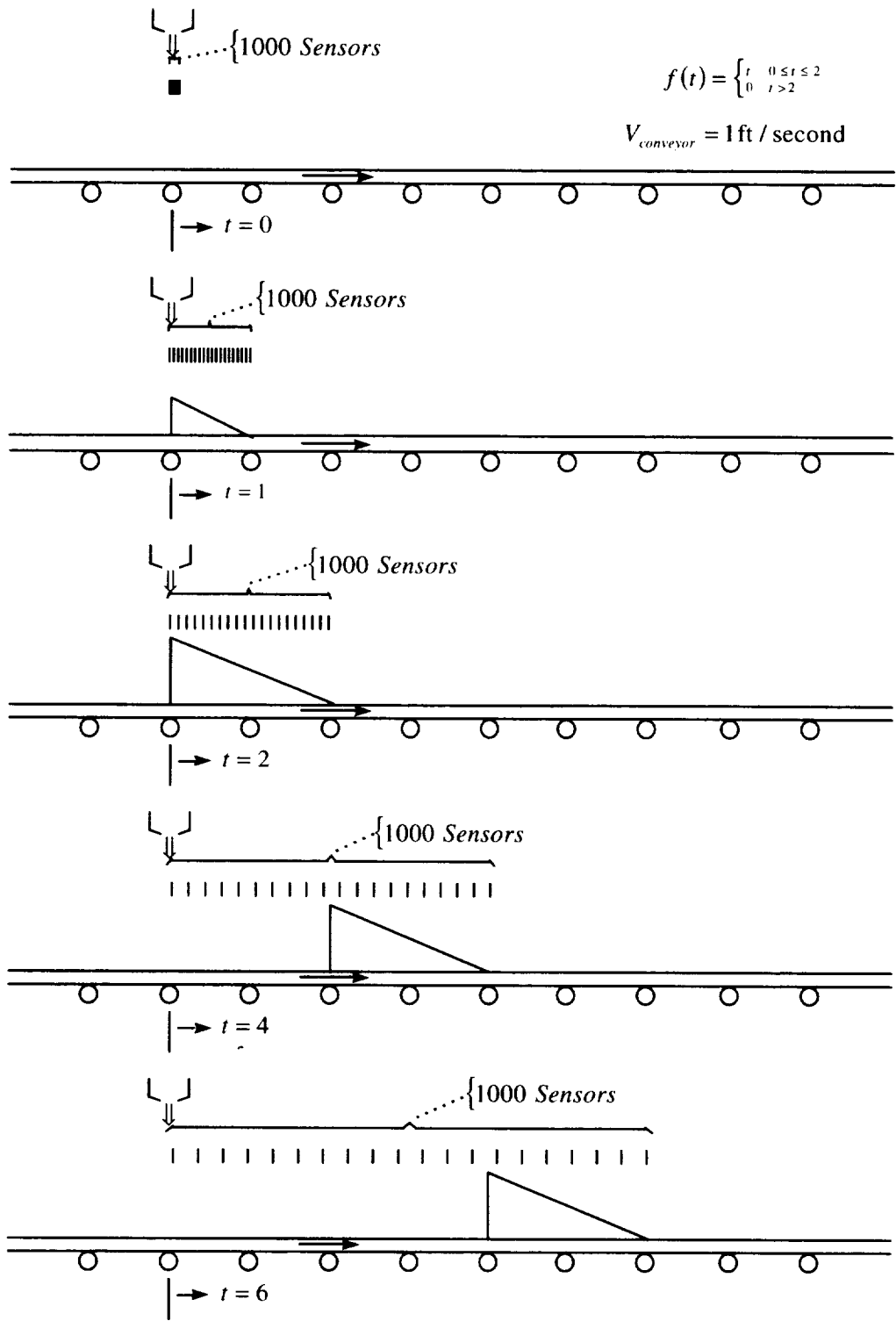

Figure 3-2-3(a).—Conveyer analogy: Fixed N , here $n = 1000$, sensors uniformly spread between 0 and t , spacing varies with t .

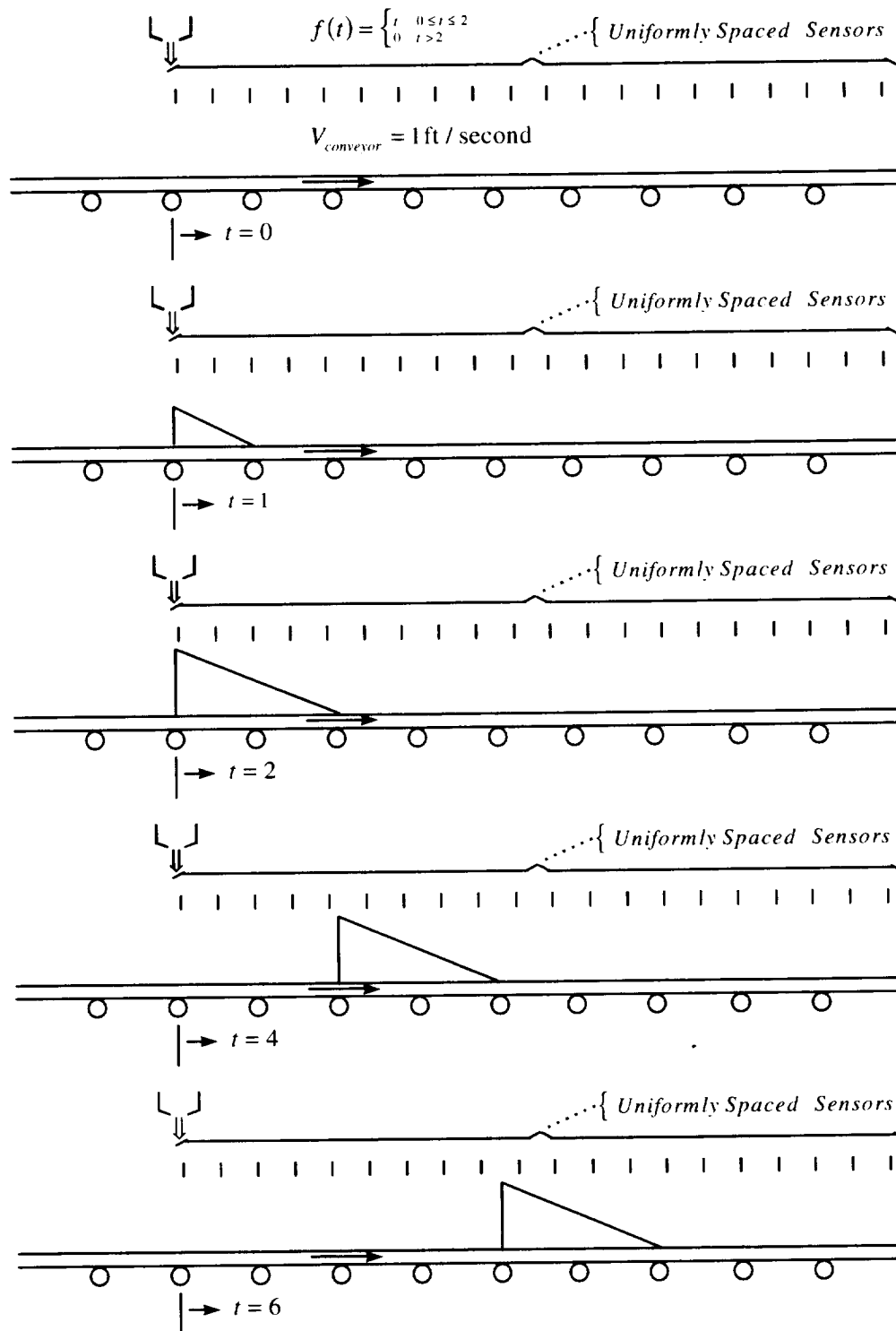

Figure 3-2-3(b).—Conveyor analogy: N variable in t , fixed in space, sensors uniformly spread in space.

A third conveyor analogy is possible. In this case the weighting sensors are evenly distributed and fixed in space. For this case the velocity $V(t)$ of the conveyor is not constant. It varies from infinite speed at the start ($t = 0$), to zero speed at $t = \infty$, in such a manner as to satisfy the required time delays. (No figure shown.)

3.2.2 Geometric Interpretation of Fractional Differintegral

A geometric conceptualization may be obtained based on the Grünwald definition. Namely,

$${}_a D_t^q f(t) = \lim_{N \rightarrow \infty} \frac{\left(\frac{t-a}{N}\right)^{-q}}{\Gamma(-q)} \sum_{j=0}^{N-1} \frac{\Gamma(j-q)}{\Gamma(j+1)} f\left(t - j\left(\frac{t-a}{N}\right)\right). \quad (3.2.2.1)$$

For simplicity we will write $(t-a)/N = \Delta T$, then since $N \rightarrow \infty$, as $\Delta T \rightarrow 0$,

$${}_a D_t^q f(t) = \lim_{\Delta T \rightarrow 0} \sum_{j=0}^{N-1} \frac{\Gamma(j-q)}{\Gamma(-q)\Gamma(j+1)} \frac{f(t-j\Delta T)}{\Delta T^q}. \quad (3.2.2.2)$$

The nature of the definition may be explored by considering the adjacent j th and $(j+1)$ th terms. In a general sense if the terms are additive and $q < 0$, then an integration is being effected. If the terms are differenced and $q > 0$ then differentiation may be suggested. Then

$${}_a D_t^q f(t) = \lim_{\Delta T \rightarrow 0} \left\{ \dots + \frac{\Gamma(j-q)}{\Gamma(-q)\Gamma(j+1)} \frac{f(t-j\Delta T)}{\Delta T^q} + \frac{\Gamma(j+1-q)}{\Gamma(-q)\Gamma(j+2)} \frac{f(t-(j+1)\Delta T)}{\Delta T^q} + \dots \right\}. \quad (3.2.2.3)$$

Dividing through by the coefficient of the j th term, and combining the j th and $(j+1)$ th terms gives

$${}_a D_t^q f(t) = \lim_{\Delta T \rightarrow 0} \left\{ \dots + \alpha \left(\frac{f(t-j\Delta T) + \beta f(t-(j+1)\Delta T)}{\Delta T^q} \right) + \dots \right\}, \quad (3.2.2.4)$$

where

$$\beta = \frac{\Gamma(j+1-q)\Gamma(j+1)}{\Gamma(j-q)\Gamma(j+2)} \quad \text{and} \quad \alpha = \frac{\Gamma(j-q)}{\Gamma(-q)\Gamma(j+1)}, \quad j = 1, 2, \dots,$$

and α is the coefficient of the j th term. Plots of α and β are presented in figure 3-2-4. Now using the gamma function relationships this may be simplified to $\beta = (j-q)/(j+1)$ when $j-q > 0$ and $j+1 > 0$.

We now restrict our attention to $1 \geq q \geq -1$. Then the simplification for β substituted into equation (3.2.2.4) holds for all terms with $j > 1$. Further, under the q restriction, β is constrained to the range of $1 \geq \beta \geq 0$ and $\beta = 1$ when $q = -1$ and approaches 1 as $j \rightarrow \infty$ for the remaining

values of q (see fig. 3-2-4). Thus, it is seen that so long as the terms above $j = 1$ exist, β will always be positive; hence the signs of the adjacent terms will be the same. Therefore, all of the considered cases will involve integration processes! It is noted that the sign of α only influences the sign of the resulting value of the integration.

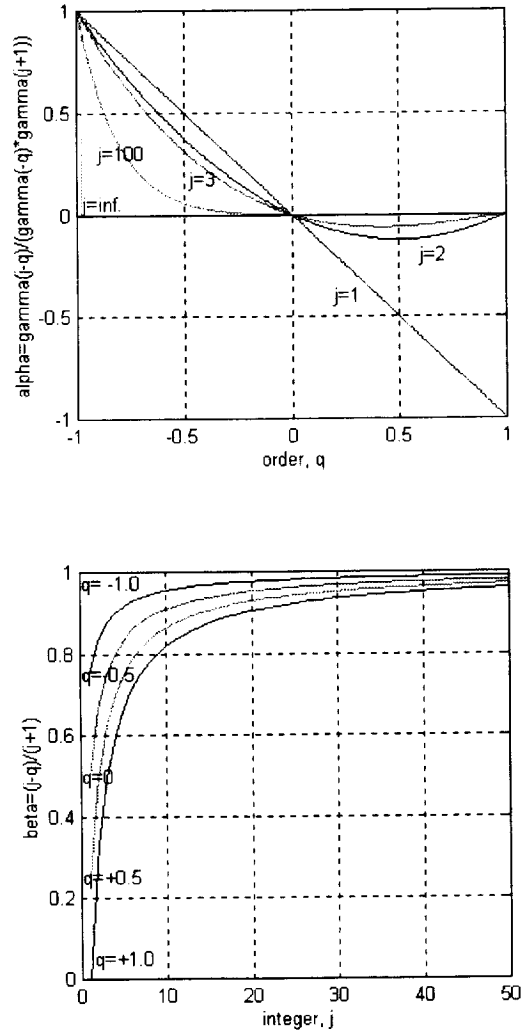

Figure 3-2-4.—Plots of $\alpha = \Gamma(j - q) / \Gamma(-q) \Gamma(j + 1)$ for various j and $\beta = (j - q) / (j + 1)$ versus j .

Now equations (3.2.2.2) and (3.2.2.4) are applied to consider four special cases.

Case 1: $q = -1$

Now $q = -1 \Rightarrow \beta = 1$, and $\alpha = 1$; further, equation (3.2.2.4) holds for all j . Equation (3.2.2.4) then simplifies to

$${}_a D_t^{-1} f(t) = \lim_{\Delta T \rightarrow 0} \left\{ \cdots + \Delta T \left[f(t - j\Delta T) + f(t - (j+1)\Delta T) \right] + \cdots \right\} \quad (3.2.2.5)$$

which is readily seen to be two terms of a conventional integration.

Case 2: $q = 1$

When $q = 1 \Rightarrow \alpha = 0$ for all j except $j = 0$ and 1 . From equation (3.2.2.2), the $j = 0$ and $j = 1$ coefficients are determined to be 1 and -1 respectively, giving

$${}_a D_t^1 f(t) = \lim_{\Delta T \rightarrow 0} \left\{ \frac{f(t) - f(t - \Delta T)}{\Delta T} \right\}, \quad (3.2.2.6)$$

which is the definition of the conventional derivative.

Case 3: $0 \geq q > -1$

For simplicity we will start with $q = -1/2 \Rightarrow \beta_{-1/2} = (j + 1/2) / (j + 1)$; thus, for all $j \geq 0 \Rightarrow 1 > \beta_{-1/2} > 0$. Here β has been subscripted to indicate the value of q . It is also true that $1 \geq \alpha > 0$ for all q in the range (fig. 3-2-4). Thus,

$${}_a D_t^{-1/2} f(t) = \lim_{\Delta T \rightarrow 0} \left\{ \dots + \alpha \Delta T^{1/2} \left[f(t - j\Delta T) + \beta_{-1/2} f(t - (j+1)\Delta T) \right] + \dots \right\}, \quad (3.2.2.7)$$

and for a general q in the range

$${}_a D_t^q f(t) = \lim_{\Delta T \rightarrow 0} \left\{ \dots + \alpha \Delta T^{-q} \left[f(t - j\Delta T) + \beta_q f(t - (j+1)\Delta T) \right] + \dots \right\}. \quad (3.2.2.8)$$

Thus, since both α and β are always positive, this summation will be seen to be an integration process (fractional). A geometric approximation to this integration is shown in figure 3-2-5(a).

Consider $q = -1$, then $\sum \alpha f(t - \Delta T) \Delta T$ is an area represented by that area beneath the $\alpha f(t - j\Delta T)$ curve. If q is taken as -2 (outside the domain of consideration here), then $\sum \alpha f(t - \Delta T) \Delta T^2$ would be a volume. Then the series $\sum \alpha f(t - \Delta T) \Delta T^{-q}$ for $0 \geq q > -1$ may be thought of as a "fractional area" (or "generalized dimension").

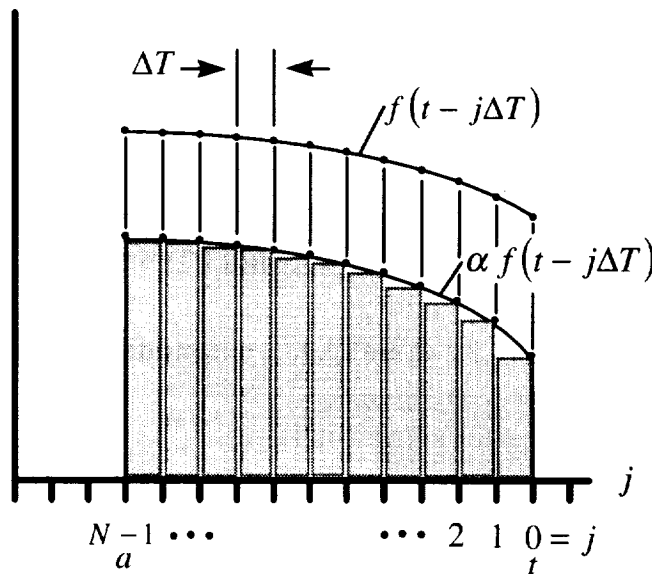

Figure 3-2-5(a).—Geometric interpretation of fractional integration; integral is area under $\alpha f(t - j\Delta T)$ curve multiplied by ΔT^{q-1} .

Case 4: $1 > q \geq 0$

Again, for simplicity, we will start with $q = 1/2$ and generalize. For $q = 1/2 \Rightarrow \beta_{1/2} = (j - 1/2)/(j + 1)$, here for all $j \geq 1 \Rightarrow 1 > \beta_{1/2} > 0$. It can be seen that β_q will be positive for all q when $j \geq 1$. It is also true that $0 > \alpha \geq -1$ for all q in the range (see fig. 3-2-4).

Thus,

$${}_a D_t^{1/2} f(t) = \lim_{\Delta T \rightarrow 0} \left\{ \dots + \alpha \Delta T^{-1/2} \left[f(t - j\Delta T) + \beta_{1/2} f(t - (j+1)\Delta T) \right] + \dots \right\}, \quad (3.2.2.9)$$

or in general for q in the range

$${}_a D_t^q f(t) = \lim_{\Delta T \rightarrow 0} \left\{ \dots + \alpha \Delta T^{-q} \left[f(t - j\Delta T) + \beta_q f(t - (j+1)\Delta T) \right] + \dots \right\}. \quad (3.2.2.10)$$

So, after the first $j = 0$ term, it is seen that all terms again are a direct sum of negatively weighted functions, again an integration process. However, the effectiveness of the weighting ΔT^{-q} is changed since now $q > 0$. The first $j = 0$ term for all q is $\Delta T^{-q} f(t)$; thus, considering the first two terms (eq. (3.2.2.2)) yields

$${}_a D_t^q f(t) = \lim_{\Delta T \rightarrow 0} \left\{ \frac{f(t) - q f(t - \Delta T)}{\Delta T^q} + \dots \right\}. \quad (3.2.2.11)$$

This brings in an effective differentiation (for $q > 0$) though scaled by ΔT^q instead of ΔT as in the case of order 1 differentiation. Therefore, fractional differentiation may be viewed as a combination of integration and differentiation.

If q is taken as 1 in equation (3.2.2.2), then, of course, the equation returns the rate of change of the function. Taking a value of $q = 2$ for the exponent of ΔT (outside the range of consideration), then equation (3.2.2.2) yields precisely $d^2 f/dt^2$, an acceleration. Thus, for $1 \geq q \geq 0$ the terms of equation (3.2.2.11) can be considered as a “fractional rate” of change of the function. Figure 3-2-5(b) shows the $j = 0$ and $j = 1$ points of a geometric approximation to the q th fractional derivative. The slope between the curves multiplied by ΔT^{-q+1} is, loosely, a geometric interpretation for this part of the fractional derivative or “fractional rate”, the remaining terms are interpreted as in figure 3-2-5(a). Of course, this interpretation becomes meaningless in the limit as $\Delta T \rightarrow 0$.

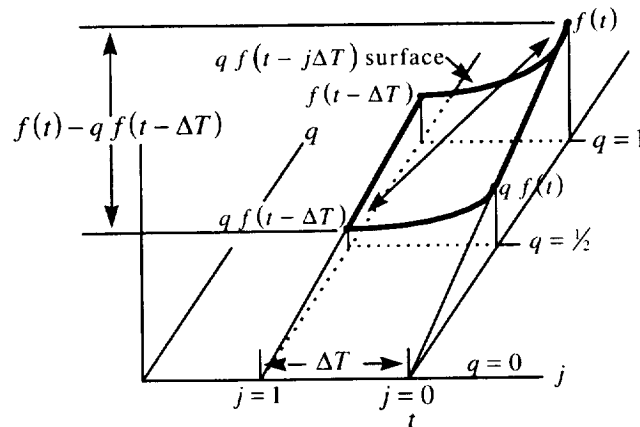

Figure 3-2-5(b).—Geometric interpretation of fractional differentiation, $j = 0 \Rightarrow j = 1$.

3.2.3 Geometric Interpretation

Considerable insight may be obtained from the examination of adjacent terms of the Grünwald definition of the fractional differintegral. The geometry of both fractional integration and differentiation at the infinitesimal level are contained in the form

$$\alpha \left(\frac{f(t - j\Delta T) + \beta f(t - (j+1)\Delta T)}{\Delta T^q} \right). \quad (3.2.3.1)$$

The graphical interpretations are as shown in figure 3-2-5.

4. Definitions for the Generalized Calculus With Initialization Functions

In view of the motivations presented in the earlier sections of this report and the desire to apply the fractional calculus to many practical applications, the following definitions are offered. Discussion will begin with a consideration of the Riemann-Liouville integral. In the development that follows, attention is restricted to real values of the order, q , of the various differintegrals.

4.1 Riemann-Liouville Basis

Two types of initialization are considered. In the first type it is assumed that the differintegral operator can only be initialized ("charged") by effectively differintegrating prior to the "start" time, $t = c$. This will be called *terminal charging* (terminal initialization) by analogy to the driving of a distributed semi-infinite electrical line, at its open terminal, by a driving function $f(t)$, for $(a < t \leq c)$. This is contrasted to *side charging* (side initialization), the second type of initialization, where by similar analogy a fully arbitrary initialization may be applied to the differintegral operator at time $t = c$. Side charging is analogous to setting an arbitrary (voltage or current) distribution on a distributed semi-infinite electrical line.

Terminal charging is considered first. It is assumed that the fractional integration of interest "starts" at $t = c$ (i.e., point of initialization). Further, $f(t) = 0$ for all $t \leq a$, and the fractional integration takes place for $t > c \geq a$.

The standard (contemporary) definition of a fractional integral will be accepted *only* when the differintegrand $f(t) = 0$ for all $t \leq a$.

Then,

$${}_a D_t^\nu f(t) \equiv \frac{1}{\Gamma(\nu)} \int_a^t (t - \tau)^{\nu-1} f(\tau) d\tau, \quad \nu \geq 0, \quad t > a, \quad (4.1.1)$$

subject to $f(t) = 0$ for all $t \leq a$. The following definition of fractional integration will apply generally (i.e., at any $t > c$):

$${}_c D_t^{-\nu} f(t) \equiv \frac{1}{\Gamma(\nu)} \int_c^t (t-\tau)^{\nu-1} f(\tau) d\tau + \psi(f, -\nu, a, c, t), \quad \nu \geq 0, \quad t > c, \quad (4.1.2)$$

$$c \geq a \text{ and } f(t) = 0 \quad \forall t \leq a.$$

The function $\psi(f, -\nu, a, c, t)$ will be called the initialization function and will be chosen such that

$${}_a D_t^{-q} f(t) = {}_c D_t^{-q} f(t) \quad \text{for } t > c. \quad (4.1.3)$$

Mathematically, then, for $t > c$ and $\nu \geq 0$,

$${}_a D_t^{-\nu} f(t) = \frac{1}{\Gamma(\nu)} \int_a^t (t-\tau)^{\nu-1} f(\tau) d\tau = {}_c D_t^{-\nu} f(t) = \frac{1}{\Gamma(\nu)} \int_c^t (t-\tau)^{\nu-1} f(\tau) d\tau + \psi(f, -\nu, a, c, t). \quad (4.1.4)$$

Clearly, since $\int_a^t f(\tau) d\tau = \int_a^c f(\tau) d\tau + \int_c^t f(\tau) d\tau$,

$$\psi(f, -\nu, a, c, t) = {}_a D_c^{-\nu} f(t) = \frac{1}{\Gamma(\nu)} \int_a^c (t-\tau)^{\nu-1} f(\tau) d\tau \quad t > c, \quad \nu > 0. \quad (4.1.5)$$

This expression for $\psi(t)$ applies only for the terminal charging condition. Clearly, ψ brings to the definition of the fractional integral the effect of the past, namely, the effect of fractionally integrating $f(t)$ from a to c . This effect will, of course, influence behavior after the time, $t = c$. The ψ function has the effect of allowing the function $f(t)$ and its derivatives to start at a value other than zero, namely, the value

$${}_a D_c^{-q} f(t) \Big|_{t=c},$$

and continues to contribute to the differintegral response after $t = c$. That is, a function of time is added to the uninitialized integral, not just a constant at $t = c$.

The integer order integrals under terminal charging are of special interest. Evaluating equation 4.1.5, for example, for $\nu = 1$, indicates that $\psi(f, -1, a, c, t) = \text{constant}$. The general case is readily shown to be

$$\psi(f, -n, a, c, t) = \sum_{i=0}^n c_i t^i, \quad n = 1, 2, 3, \dots$$

This, of course, is the same effect as seen in the integer order calculus using the “constant of integration.”

When side charging is in effect as opposed to terminal charging, then,

$$\psi = \psi(t) \text{ (i.e., is arbitrary).}$$

It is important to note that the initialization of the q th fractional integral of $f(t)$ is not unique in the following sense. That is, $f(t)$ can be considered as a composite function, for example, $f(t) = g(t)U(t-c) + h(t)(U(t-a) - U(t-c))$, where $U(t)$ is the unit step function

$$U(t) = \begin{cases} 0 & t < 0 \\ 1 & t > 0 \end{cases} .$$

Then for this composite function $f(t)$, it is the function $g(t)U(t-c)$ that is being differintegrated and $h(t)(U(t-a) - U(t-c))$ is the function on which the initialization is based. This is analogous to choosing an arbitrary constant value to initialize (the integration of) dy/dt in the solution of an ordinary differential equation. The point is that in many (perhaps most) applications it will be the analyst's choice as to how $h(t)(U(t-a) - U(t-c))$ will be chosen in the initialization of ${}_c D_t^{-\nu} f(t)$. In many cases, for example for the integer order (differintegrals) calculus as considered in the contemporary context, $h(t) = \text{constant}$ will be the appropriate choice. Issues of discontinuities at $t = c$ of course must be addressed.

To extend the definition to the fractional derivatives, some issues must be addressed. The definition of the fractional derivative raises the following important questions in the context of initialization. *Do fractional derivatives require an initializing function in general? Further, do integer order derivatives in this context require initialization functions?* Clearly, as we commonly think of derivatives, in the integer order calculus, the derivative is a local property and is represented geometrically as the slope of the function being considered and as such it requires no initialization. In the solution of differential equations the initialization constants which set the initial values of the derivatives really have the effect of accounting for the integration of the derivative from minus infinity to the starting time of the integration (of the differential equation).

The authors' study of the semi-infinite bar dynamics (Hartley and Lorenzo (1998)) together with implication from the conveyor analogy based on the Grünwald definition of the fractional derivative, indicate that the fractional derivative is not a local property as appears to be the case for integer order derivatives (in the integer order calculus). Further, if it is desired to use the fractional calculus (and hence the fractional derivative) to write FODE's such as that representing the input behavior of the semi-infinite bar, then an initialization function *is* required to handle the effect of the distributed initialization (initial strain distribution in the bar). The input characteristic (for displacement to force) in this case is $df(t)/dt$ (that is, an integer derivative but in a fractional context). Therefore, in the opinion of the authors, the answer to both questions is clearly, YES. Physical examples will be shown later in this paper to further justify this position. The impact of this is to require an initialization function for the fractional (and integer order) derivatives.

Thus, a generalized integer order differentiation is defined as

$${}_c D_t^m f(t) \equiv \frac{d^m}{dt^m} f(t) + \psi(f, m, a, c, t) \quad t > c, \quad (4.1.6)$$

where m is a positive integer and where $\psi(f, m, a, c, t)$ is an initialization function. This is, of course, a generalization of the definition of the derivative, and for many cases, for example, usually in the integer order calculus, ψ will be taken to be zero. It will be shown in a later section that, for $m=1$ with the condition of terminal charging, $\psi(f, 1, a, c, t) = 0$.

Now the *uninitialized* generalized (fractional) derivative is defined as

$${}_a D_t^q f(t) \equiv {}_a D_t^m {}_a D_t^{-p} f(t) \quad q \geq 0, t > a, \text{ and } f(t) = 0 \quad \forall t \leq a \quad (4.1.7)$$

and (for convenience) m is the least integer greater than q , and $q = m - p$. Now as in the fractional integral case $\psi(f, -p, a, a, t) = 0$. Further, since $\psi(h, m, a, a, t) = 0$, where $h(t) = {}_a D_t^{-p} f(t)$, this definition specializes to the contemporary definition of the fractional derivative.

Now the *initialized* generalized (fractional) derivative is defined as

$${}_c D_t^q f(t) \equiv {}_c D_t^m {}_c D_t^{-p} f(t) \quad q \geq 0, \quad t > c \geq a, \quad (4.1.8)$$

where (for convenience) m is the least positive integer greater than q and $q = m - p$.

The initialization of the fractional derivative under conditions of terminal charging will proceed in a manner similar to the fractional integral, that is, it shall be required that

$${}_c D_t^q f(t) = {}_a D_t^q f(t) \quad \forall t > c \quad \text{with } q \geq 0. \quad (4.1.9)$$

Specifically, this requires compatibility of the derivatives starting at $t = a$ and $t = c$, for $t > c$.

Then it follows that

$${}_c D_t^m {}_c D_t^{-p} f(t) = {}_a D_t^m {}_a D_t^{-p} f(t), \quad q > 0, \quad t > c \geq a. \quad (4.1.10)$$

Expanding the generalized integral terms,

$${}_c D_t^m \left(\frac{1}{\Gamma(p)} \int_c^t (t-\tau)^{p-1} f(\tau) d\tau + \psi(f, -p, a, c, t) \right) = {}_a D_t^m \left(\frac{1}{\Gamma(p)} \int_a^t (t-\tau)^{p-1} f(\tau) d\tau + \psi(f, -p, a, a, t) \right), \quad t > c. \quad (4.1.11)$$

Since $\psi(f, -p, a, a, t) = 0$ and using the definition (eq. (4.1.6)) for the integer order derivative, equation (4.1.11) may be written as

$$\frac{d^m}{dt^m} \left\{ \frac{1}{\Gamma(p)} \int_c^t (t-\tau)^{p-1} f(\tau) d\tau + \psi(f, -p, a, c, t) \right\} + \psi(h_1, m, a, c, t) = \frac{d^m}{dt^m} \frac{1}{\Gamma(p)} \int_a^t (t-\tau)^{p-1} f(\tau) d\tau + \psi(h_2, m, a, a, t), \quad t > c, \quad (4.1.12)$$

where $h_1 = {}_a D_t^{-p} f(t)$ and $h_2 = {}_a D_t^{-p} f(t)$. The integer derivative is uninitialized at $t = a$, therefore $\psi(h_2, m, a, a, t) = 0$. Then combining integrals gives

$$\psi(h_1, m, a, c, t) = \frac{d^m}{dt^m} \left(\frac{1}{\Gamma(p)} \int_a^c (t-\tau)^{p-1} f(\tau) d\tau - \psi(f, -p, a, c, t) \right) \quad t > c. \quad (4.1.13)$$

Under the condition of terminal charging of the fractional integral (eq. (4.1.5)), the argument of the derivative above is zero thus $\psi(h_1, m, a, c, t) = 0$ and it is seen **that integer differentiation cannot be initialized through the terminal (terminal charged)**. This feature will also be demonstrated in the applications section to follow. For the case of side charging $\psi(f, -p, a, c, t)$ is arbitrary. Thus it can be seen from the above equation that either $\psi(f, -p, a, c, t)$ or $\psi(h_1, m, a, c, t)$ can be arbitrary but not both while still satisfying the requirements of the initialization (eq. (4.1.1.3)).

Thus, the generalized (fractional) derivative, side charging case, can now be stated as

$${}_c D_t^q f(t) = {}_c D_t^m \left\{ \frac{1}{\Gamma(p)} \int_c^t (t-\tau)^{p-1} f(\tau) d\tau + \psi(f, -p, a, c, t) \right\}, \quad q \geq 0, t > c, \quad (4.1.14)$$

and m is the least positive integer $> q$ with $q = m - p$, or equivalently as

$${}_c D_t^q f(t) = \frac{d^m}{dt^m} \frac{1}{\Gamma(p)} \int_c^t (t-\tau)^{p-1} f(\tau) d\tau + \frac{d^m}{dt^m} \psi(f, -p, a, c, t) + \psi(h, m, a, c, t) \quad q \geq 0 \quad (4.1.14a)$$

where m is as above, $t > c$, and $h(t) = {}_a D_t^{-p} f(t)$.

In the case of terminal charging of the fractional integral part of equation (4.1.14) $\psi(f, -p, a, c, t)$ will be as defined by equation (4.1.5).

4.1.1 Simple Example

A simple example will be helpful. Consider the semi-integral of $f(t) = (t-a)U(t-a)$, then for the uninitialized semi-integral (Oldham and Spanier (1974) pp. 63-64)

$${}_a D_t^{-1/2} (t-a)U(t-a) = \frac{(t-a)^{1-q}}{\Gamma(2-q)} = \frac{(t-a)^{3/2}}{\Gamma(2.5)} \approx 0.75225(t-a)^{3/2}, \quad t > a. \quad (4.1.15)$$

Now, initializing from the point $t = c$

$${}_c D_t^{-1/2} (t-a)U(t-a) = \frac{1}{\Gamma(1/2)} \int_c^t (t-\tau)^{-1/2} (\tau-a) d\tau + \psi(f, -1/2, a, c, t), \quad t > c, \quad (4.1.16)$$

and,

$${}_c D_t^{-1/2} (t-a)U(t-a) = \frac{2}{3\Gamma(1/2)} \left((t-c)^{1/2} (2t+c-3a) \right) + \psi(f, -1/2, a, c, t), \quad t > c. \quad (4.1.17)$$

Consider now the terminally charged initialization,

$$\psi(f,-1/2,a,c,t) = \frac{1}{\Gamma(1/2)} \int_a^c (t-\tau)^{-1/2} (\tau-a) d\tau, \quad t > c, \quad (4.118)$$

$$\psi(f,-1/2,a,c,t) = \frac{2}{3\Gamma(1/2)} \left[(t-c)^{1/2} (-2t+3a-c) - (t-a)^{1/2} (-2t+2a) \right], \quad t > c. \quad (4.119)$$

For specific numerical values, for example, $a = -1, c = 1$, the above results give

$$\begin{aligned} {}_1D_t^{-1/2}(t-a)U(t-a) &= 0.75225(t+1)^{3/2}, \quad t > -1, \\ {}_1D_t^{-1/2}(t-a)U(t-a) &= \frac{2}{3\sqrt{\pi}} \left((t-1)^{1/2}(2t+4) \right) + \psi(f,-1/2,-1,1,t), \quad t > 1, \end{aligned} \quad (4.120)$$

with

$$\psi(f,-1/2,-1,1,t) = \frac{2}{3\sqrt{\pi}} \left(-(t-1)^{1/2}(2t+4) + (t+1)^{1/2}(2t+2) \right), \quad t > 1. \quad (4.121)$$

The numerical evaluations of these quantities are shown in the graphs of figure 4-1-1. It is observed, at least for this case, that

$$\lim_{t \rightarrow \infty} \psi(f,-v,a,c,t) = 0. \quad (4.122)$$

Further, for $t \geq c=1$, $\psi(t)$ appears to decrease monotonically.

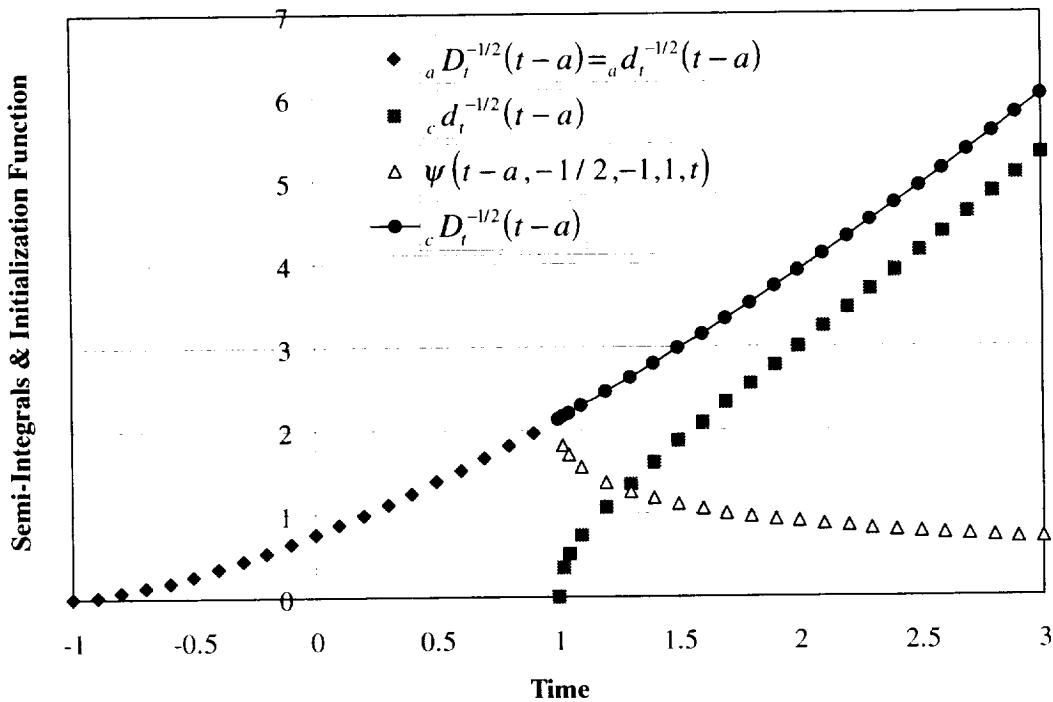

Figure 4-1-1.—Sample problem: semi-integral of $(t-a)$ versus Time, with $a = -1, c = 1$.

Summary of Definitions

The **generalized (fractional) integral**, for ν arbitrary, real, and non-negative:

$${}_c D_t^\nu f(t) \equiv \frac{1}{\Gamma(\nu)} \int_c^t (t-\tau)^{\nu-1} f(\tau) d\tau + \psi(f, \nu, a, c, t), \quad \nu \geq 0 \quad (4.1.23)$$

$$t > c \geq a \text{ and } f(t) = 0 \quad \forall t \leq a.$$

The **generalized integer derivative**:

$${}_c D_t^m f(t) \equiv \frac{d^m}{dt^m} f(t) + \psi(f, m, a, c, t), \quad t > c, \quad (4.1.24)$$

where m is a positive integer and where $\psi(f, m, a, c, t)$ is arbitrary.

The **generalized (fractional) derivative**, q and p real:

$${}_c D_t^q \equiv {}_c D_t^m {}_c D_t^{-p} f(t) = \frac{d^m}{dt^m} \frac{1}{\Gamma(p)} \int_c^t (t-\tau)^{p-1} f(\tau) d\tau + \frac{d^m}{dt^m} \psi(f, p, a, c, t) + \psi(h, m, a, c, t), \quad (4.1.25)$$

where $t > c$, $h = {}_a D_t^{-p} f(t)$, $q = m - p > 0$, $p > 0$ and m is integer.

General case **side charging**:

$\psi(t)$ is arbitrary.

Terminal charging case for generalized (fractional) integral:

$$\psi(f, \nu, a, c, t) = {}_a D_c^\nu f(t) = \frac{1}{\Gamma(\nu)} \int_a^c (t-\tau)^{\nu-1} f(\tau) d\tau \quad t > c, \nu \geq 0 \quad (4.1.26)$$

for integer derivative

$$\psi(h, m, a, c, t) = 0. \quad (4.1.27)$$

4.2 Grünwald Basis

This discussion parallels that for the Riemann-Liouville basis. Again the "starting" time for the differintegration is $t = c$. An initialization is introduced to account for previous history and goes back to $t = a$, with $f(t) = 0$ for all $t \leq a$. Then for arbitrary q ,

$${}_a D_t^q f(t) = \frac{d^q f(t)}{[d(t-a)]^q} \Big|_{GRUN} \equiv \lim_{N \rightarrow \infty} \frac{\left(\frac{t-a}{N}\right)^{-q}}{\Gamma(-q)} \sum_{j=0}^{N-1} \frac{\Gamma(j-q)}{\Gamma(j+1)} f\left(t - j\left(\frac{t-a}{N}\right)\right), \quad t > a, \quad (4.2.1)$$

subject to $f(t) = 0$ for all $t \leq a$.

The following definition of Grünwald differintegration will apply generally (i.e., at any $t > c \geq a$):

$${}_c D_t^q f(t) \equiv \frac{d^q f(t)}{[d(t-c)]^q} \Big|_{GRUN} + \psi_G(f, q, a, c, t) \quad (4.2.2)$$

and $f(t) = 0, \forall t \leq a, c \geq a$.

Again $\psi_G(f, q, a, c, t)$ is chosen such that ${}_c D_t^q f(t)$ will produce the same result as ${}_a D_t^q f(t)$ for $t > c$.

Mathematically,

$${}_c D_t^q f(t) = {}_c d_t^q f(t) \Big|_{GRUN} + \psi_G(f, q, a, c, t) = {}_a D_t^q f(t), \quad (4.2.3)$$

for all $t > c$, and $f(t) = 0$ for all $t \leq a$, and $c \geq a$.

Therefore,

$$\psi_{GRUN}(f, q, a, c, t) = {}_a D_t^q f(t) - {}_c d_t^q f(t) \Big|_{GRUN}, \quad (4.2.4)$$

subject to $f(t) = 0 \forall t \leq a$ and $a \leq c < t$

or

$$\psi_{GRUN}(f, q, a, c, t) = {}_a d_t^q f(t) \Big|_{GRUN} - {}_c d_t^q f(t) \Big|_{GRUN}, \quad (4.2.5)$$

subject to $f(t) = 0 \forall t \leq a, a \leq c < t$.

Now substituting the Grünwald series definition from equation (4.2.1) gives

$$\begin{aligned} \psi_G(f, q, a, c, t) = \lim_{N_1 \rightarrow \infty} & \left\{ \frac{\left(\frac{t-a}{N_1}\right)^{-q}}{\Gamma(-q)} \sum_{j=0}^{N_1-1} \frac{\Gamma(j-q)}{\Gamma(j+1)} f\left\{t - j\left(\frac{t-a}{N_1}\right)\right\} \right\} \\ & - \lim_{N_2 \rightarrow \infty} \left\{ \frac{\left(\frac{t-c}{N_2}\right)^{-q}}{\Gamma(-q)} \sum_{j=0}^{N_2-1} \frac{\Gamma(j-q)}{\Gamma(j+1)} f\left\{t - j\left(\frac{t-c}{N_2}\right)\right\} \right\}, \end{aligned} \quad (4.2.6)$$

subject to $t > c$, and $f(t) = 0$ for all $t \leq a$.

The above expression can be simplified greatly by making the delay increments in the two summations equal, that is, $N_2 = ((t-c)/(t-a)) N_1$. Then after considerable algebra and manipulation of indices

$$\psi_G(f, q, a, c, t) = \lim_{N_1 \rightarrow \infty} \left\{ \frac{\Delta T^{-q}}{\Gamma(-q)} \sum_{j=0}^{N_1-1} \frac{\Gamma(N_1-1-q-j)}{\Gamma(N_1-j)} f\left\{t - (N_1-1-j)\Delta T\right\} \right\}, \quad (4.2.7)$$

where $\Delta T = (t-a)/N_1, t > c \geq a$ and N_1 and N_3 are integers such that $N_3 = ((c-a)/(t-a))N_1$.

4.3 Notation

It is important to clarify notation before proceeding further. The following notation will be used in the remainder of this paper:

$${}_c D_t^q f(t) = {}_c d_t^q f(t) + \psi(f, q, a, c, t), \quad t > c, \quad (4.3.1)$$

where ${}_c D_t^q f(t)$ represents the initialized q th order differintegration of $f(t)$.

Thus,

$${}_c d_t^q f(t) = \left. \frac{d^q f(t)}{[d(t-c)]^q} \right|_{o\&s} = {}_c D_t^q f(t) \Big|_{ROSS}, \quad (4.3.2)$$

is an uninitialized generalized (or fractional) q th order differintegral and is the same as defined in Oldham and Spanier (1974) and Ross (1974). Its basis is either the Riemann-Liouville integral (and successive differentiations) or the Grünwald series definition. The notational form

$${}_c D_t^q f(t), \quad (4.3.3)$$

is now used to represent the initialized differintegral, that is, it includes the $\psi(t)$ initialization function. It is unfortunate that this form is widely used in the literature at this time to represent the **un**initialized differintegral; but it is the authors' judgment that any confusion arising from this change will be more than offset by the convenience of the compact notation. As described above $\psi(f, q, a, c, t)$ is an initialization for the q th order differintegral of $f(t)$ where it is required that $a \leq c$ and that $f(t) = 0$ for $t \leq a$. For convenience $\psi(f, q, a, c, t)$ will occasionally be replaced by $\psi(t)$ or $\psi(f, q, t)$ where the meaning is clear from the context. In similar manner, ${}_c d_t^q f(t)$ will occasionally be replaced by $d^q f(t)$.

5. Criteria for a Generalized (Fractional) Calculus

5.1 Ross' Criteria

This section examines selected properties, which can reasonably be expected to apply to fractional differintegral operators. A minimal set of criteria for a viable generalized calculus has been established by Ross (1974b). This set *is accepted in principle by the authors* and is quoted as follows:

The Ross Criteria:

- “1. If $f(z)$ is an analytic function of the complex variable z , the derivative ${}_c D_z^v f(z)$ is an analytic function of v and z .

2. The operation ${}_c D_x^\nu f(x)$ must produce the same result as ordinary differentiation when ν is a positive integer. If ν is a negative integer, say $\nu = -n$, then ${}_c D_x^n f(x)$ must produce the same result as ordinary n -fold integration and ${}_c D_x^n f(x)$ must vanish along with its $n-1$ derivatives at $x = c$.
3. The operation of order zero leaves the function unchanged:

$${}_c D_x^0 f(x) = f(x). \quad (5.1.1)$$

4. The fractional operators must be linear:

$${}_c D_x^q [af(x) + bg(x)] = a {}_c D_x^q f(x) + b {}_c D_x^q g(x). \quad (5.1.2)$$

5. The law of exponents for integration of arbitrary order holds

$${}_c D_x^\mu {}_c D_x^\nu f(x) = {}_c D_x^{\mu+\nu} f(x). \quad (5.1.3)$$

It is observed that the notation, ${}_a D_x^q f(x)$, is exactly that of Ross and refers to the **uninitialized** differintegral.

The requirement here is to examine the proposed generalized calculus against the spirit of these criteria. It should be noted that there is a minor conflict contained in these criteria. Namely, criterion 2 basically calls for backward compatibility with the integer order calculus while criterion 5 calls for the index law to hold. It should be noted that, for the normal Riemann-Stieltjes integration theory in the integer order calculus,

$$d^{-m} d^m f(x) \neq d^0 f(x) = f(x) \quad (5.1.4)$$

for all $f(x)$ and all m . This is observed directly by application of the “Fundamental theorem” of calculus (Apostol (1957) p. 215). This states that under appropriate conditions

$$\int_c^t f'(t) dt = f(t) - f(c), \quad (5.1.5)$$

and it can be seen that the reversal of differentiation by integration really differs from $f(t)$ by $f(c)$, that is, by the initialization. Thus, the fact is that the integer order calculus itself does not satisfy all the criteria. The failure of the fundamental theorem to provide true reversibility of differentiation by integration is handled in the integer calculus in an ad hoc manner, specifically, by the use of the constant of integration and by the use of the complementary function in the solution of differential equations.

The issue to be addressed is: *Do the initialized versions of the Riemann-Liouville and Grünwald differintegral definitions satisfy the above criteria?* Since Oldham and Spanier (1974) show the equivalence of the Riemann-Liouville and Grünwald uninitialized definitions, and since the Riemann-Liouville basis relates most closely to the classical calculus it will be the main consideration of this effort. Further, since the focus of this paper is limited to q in the real domain,

only the last four of the criteria will be considered here. It is noted that, at least for continuous functions, the condition $f(t) = 0$ for $\forall t \leq a$, at $t = a$, is equivalent to the condition that is used by Ross (1974a and 1974b), namely, $f(t), f'(t), f''(t), \dots, f^{(n)}(t) = 0$ for $\forall n$ and $\forall t < a$.

A general consideration of the Ross criteria relative to the generalized calculus proposed here allows the following to be established.

For $f(t), f'(t), f''(t), \dots, f^{(n)}(t) = 0$ for $\forall n$ and $\forall t \leq a$ and under the condition of terminal charging, criteria 2,3,4,and 5 hold for all ${}_c D_t^q f(t)$, with $t > c$.

Proof: Since each criterion has been proven (Ross (1974a and 1974b)) for the uninitialized differintegral under the condition $f(t), f'(t), f''(t), \dots, f^{(n)}(t) = 0$ for $\forall n$ and $\forall t \leq a$. And since for terminal charging, the generalized integer derivative becomes

$${}_c D_t^m f(t) = \frac{d^m}{dt^m} f(t), \quad t > c, \quad (5.1.6)$$

and further, because $\psi(f, q, a, a, t) = 0 \quad \forall q$ then,

$${}_a D_t^q f(t) = {}_a D_t^q f(t) \Big|_{ROSS} \quad (5.1.7)$$

(Note ${}_a D_t^q f(t) \Big|_{ROSS}$ here represents the uninitialized differintegral). Hence, since all criteria hold for ${}_a D_t^q f(t) \Big|_{ROSS}$ when $f^{(n)}(t) = 0 \quad \forall n$ and $\forall t \leq a$, and since

$${}_c D_t^q f(t) = {}_a D_t^q f(t), \quad \text{for all } t > c \text{ and all } q, \quad (5.1.8)$$

it follows that the criteria also apply to the initialized differintegral,

$${}_c D_t^q f(t), \quad \text{for all } q \text{ and } t > c,$$

thus completing the proof.

The criteria are now examined separately, to detail the proof for each criterion, to determine the implications relative to the initialization functions (ψ 's), and to determine the limitations for the generalized case, that is, for the case of side charging and/or the case of an initialized integer derivative.

5.2 Criterion 2: Backward Compatibility

The purpose of Criterion 2 is to require backward compatibility with the integer order calculus. Namely, it is required that

$${}_c D_t^n f(t) = \begin{cases} \frac{d^n f(t)}{dt^n} & n > 0, \\ \text{or} & n = \text{integer.} \\ \int_c^t \dots \int_c^{t_{n-2}} f(t_{n-1}) dt_{n-1} \dots dt_1 & n < 0, \end{cases} \quad (5.2.1)$$

Ross (1974b) uses induction to prove compatibility for the uninitialized fractional integral, thus when ν becomes a positive integer n ,

$${}_0d_t^{-n} f(t) = \frac{1}{\Gamma(n)} \int_0^t (t-\tau)^{n-1} f(\tau) d\tau$$

produces the same result as n -iterated ordinary integration. Now by definition,

$${}_cD_t^n f(t) \equiv \frac{1}{\Gamma(n)} \int_c^t (t-\tau)^{n-1} f(\tau) d\tau + \psi(f, -n, a, c, t), \quad n \geq 0, \quad (4.1.23)$$

$$t > c \geq a, \text{ and } f(t) = 0 \quad \forall t \leq a,$$

and since for side charging $\psi(f, -n, a, c, t)$ is arbitrary, for backward compatibility (i.e., to satisfy eq. (5.2.1)) it may be taken as zero. For terminal charging, $f(t)$ can be defined to be identically zero for $a \leq t < c$. Thus, backward compatibility is obtainable for the generalized integral when ν is a positive integer.

The backward compatibility of the generalized derivative ${}_cD_t^q f(t)$, $q > 0$ to the integer order derivative $\frac{d^n f(t)}{dt^n}$, when q is replaced by n , requires that the zero property (criterion 3)

hold for the fractional integral part of equation (4.1.8). This property is independently established in the next subsection and will therefore be used freely here. Then as $p \rightarrow 0$, equation (4.1.8) becomes

$$\begin{aligned} \lim_{q \rightarrow m} {}_cD_t^q f(t) &= \lim_{p \rightarrow 0} {}_cD_t^m {}_cD_t^{-p} f(t) && q \geq 0, \quad t > c \geq a \\ &= {}_cD_t^m f(t) = \frac{d^m}{dt^m} f(t) + \psi(f, m, a, c, t) \end{aligned} \quad (5.2.2)$$

and for terminal charging it has been shown that $\psi(f, m, a, c, t) = 0$, and under side-charging conditions ψ is arbitrary and may be set to zero. Thus, backward compatibility for the fractional derivative is obtainable.

5.3 Criterion 3: Zero Property

For criterion 3, it is necessary to prove that

$${}_cD_t^0 f(t) = f(t). \quad (5.3.1)$$

Now, by definition, and using the Riemann-Liouville form for the fractional integral

$${}_cD_t^0 f(t) = \lim_{\nu \rightarrow 0} \left(\frac{1}{\Gamma(\nu)} \int_c^t (t-\tau)^{\nu-1} f(\tau) d\tau + \psi(f, \nu, a, c, t) \right), \quad t > c, \quad (5.3.2)$$

and for terminal charging

$$= \lim_{\nu \rightarrow 0} \left(\frac{1}{\Gamma(\nu)} \int_c^t (t-\tau)^{\nu-1} f(\tau) d\tau + \frac{1}{\Gamma(\nu)} \int_a^c (t-\tau)^{\nu-1} f(\tau) d\tau \right), \quad \text{and} \quad (5.3.3)$$

$${}_c D_t^0 f(t) = \lim_{\nu \rightarrow 0} \frac{1}{\Gamma(\nu)} \int_a^t (t-\tau)^{\nu-1} f(\tau) d\tau = \lim_{\nu \rightarrow 0} ({}_a D_t^\nu f(t)), \quad t > c. \quad (5.3.4)$$

Now in this form the differintegral has the initialization, $f(t) = 0$, for $\forall t \leq a$, that is, $\psi(f, -\nu, a, a, t) = 0$. Now Ross shows by several methods that

$$\lim_{\nu \rightarrow 0} \frac{1}{\Gamma(\nu)} \int_0^t (t-\tau)^{\nu-1} f(\tau) d\tau = f(t). \quad (5.3.5)$$

Thus, it is seen that the initializing function does not affect order zero behavior of the fractional integral with terminal charging conditions.

Approaching zero order from the derivative (positive) side, taking $q = m - p = 1 - p$, since no generality is lost by taking $m = 1$,

$${}_c D_t^0 f(t) = \lim_{q \rightarrow 0} {}_c D_t^q f(t) = \lim_{p \rightarrow 1} {}_c D_t^1 {}_c D_t^{-p} f(t) \quad (5.3.6)$$

$$= \lim_{p \rightarrow 1} \frac{d}{dt} \left(\frac{1}{\Gamma(p)} \int_c^t (t-\tau)^{p-1} f(\tau) d\tau + \psi(f, -p, a, c, t) \right) + \psi(h, m, a, c, t), \quad t > c. \quad (5.3.7)$$

Then for terminal charging of the integer derivative $\psi(h, m) = 0$ and for the fractional integral,

$$\psi(f, -p, a, c, t) = \frac{1}{\Gamma(p)} \int_a^c (t-\tau)^{p-1} f(\tau) d\tau, \quad t > c, \quad (5.3.8)$$

thus,

$${}_c D_t^0 f(t) = \lim_{p \rightarrow 1} \frac{d}{dt} \left(\frac{1}{\Gamma(p)} \int_a^t (t-\tau)^{p-1} f(\tau) d\tau \right), \quad \text{and} \quad (5.3.9)$$

$$= \frac{d}{dt} \int_a^t f(\tau) d\tau, \quad t > a. \quad (5.3.10)$$

Under conditions of continuity of $f(t)$ and $f'(t)$, the order of operations can be interchanged and by the fundamental theorem of calculus

$${}_c D_t^0 f(t) = \int_a^t f'(\tau) d\tau = f(t) - f(a) = f(t), \quad (5.3.11)$$

since by definition $f(a) = 0$, completing the proof. For side charging the zero order operation will return

$$\boxed{{}_c D_t^0 f(t) = f(t) + \psi(t)}. \quad (5.3.12)$$

That this is an acceptable and indeed important result will be demonstrated in a later section.

5.4 Criterion 4: Linearity

Linearity becomes somewhat more involved with the presence of the initialization function in the definition. The requirements for the fractional integral will be determined first.

The following two fractional integrals are defined:

$${}_c D_t^{-\nu} f(t) = \frac{1}{\Gamma(\nu)} \int_c^t (t-\tau)^{\nu-1} f(\tau) d\tau + \psi(f, -\nu, a, c, t), \quad t > c, \text{ and} \quad (5.4.1)$$

$${}_c D_t^{-\nu} g(t) = \frac{1}{\Gamma(\nu)} \int_c^t (t-\tau)^{\nu-1} g(\tau) d\tau + \psi(g, -\nu, a, c, t), \quad t > c, \quad (5.4.2)$$

where $f(t) = 0 \quad \forall t \leq a$ and $g(t) = 0 \quad \forall t \leq a$.

Now, for $t > c$ consider,

$$\begin{aligned} {}_c D_t^{-\nu} (bf(t) + kg(t)) &= \frac{1}{\Gamma(\nu)} \int_c^t (t-\tau)^{\nu-1} (bf(\tau) + kg(\tau)) d\tau + \psi(bf + kg, -\nu, a, c, t) \\ &= \frac{b}{\Gamma(\nu)} \int_c^t (t-\tau)^{\nu-1} f(\tau) d\tau + \frac{k}{\Gamma(\nu)} \int_c^t (t-\tau)^{\nu-1} g(\tau) d\tau + \psi(bf + kg, -\nu, a, c, t). \end{aligned} \quad (5.4.3)$$

Now using the definitions from equations (5.4.1) and (5.4.2) to replace the integral terms in this equation gives:

$$\begin{aligned} {}_c D_t^{-\nu} (bf(t) + kg(t)) &= b({}_c D_t^{-\nu} f(t) - \psi(f, -\nu, a, c, t)) + \\ &\quad k({}_c D_t^{-\nu} g(t) - \psi(g, -\nu, a, c, t)) + \psi(bf + kg, -\nu, a, c, t), \quad t > c. \end{aligned} \quad (5.4.4)$$

Clearly,

$${}_c D_t^{-\nu} (bf(t) + kg(t)) = b {}_c D_t^{-\nu} f(t) + k {}_c D_t^{-\nu} g(t), \quad t > c, \quad (5.4.5)$$

and linearity is obtained if an only if

$$\psi(bf + kg, -\nu, a, c, t) = b\psi(f, -\nu, a, c, t) + k\psi(g, -\nu, a, c, t), \quad t > c. \quad (5.4.6)$$

Fundamentally, equation (5.4.6) presents the requirement on the initialization of the individual functions to produce the same result as that given by the initialization of the combined functions.

Extension of the linearity requirements to fractional derivatives, while not complex, is simplified by use of the following shorthand for the uninitialized fractional integral,

$$d^{-q} f(t) = {}_c d_t^{-q} f(t) = \frac{1}{\Gamma(q)} \int_c^t (t-\tau)^{q-1} f(\tau) d\tau, \quad q > 0 \quad (5.4.7)$$

and

$$d^m f(t) = \frac{d^m f(t)}{dt^m}, \quad m > 0. \quad (5.4.8)$$

The problem here is to show

$${}_c D_t^r (bf(t) + kg(t)) = b {}_c D_t^r f(t) + k {}_c D_t^r g(t), \quad r > 0, \quad t > c. \quad (5.4.9)$$

Using the definition for the generalized derivative (eq. (4.1.8)),

$${}_c D_t^r f(t) = {}_c D_t^m {}_c D_t^{-v} f(t), \quad t > c, \quad (5.4.10)$$

where m is an integer and $m > v \geq 0$ and $r = m - v$. Now, ${}_c D_t^m$ is an initialized integer order

m th derivative operator composed of two parts, $\frac{d^m}{dt^m}$ the normal derivative operator, and

$\psi(h_1, m)$ the initializing function. Also, for equation (5.4.10), $h_1 = {}_a d_t^{-v} f(t)$.

For $t > c$, linearity holds when for equation (5.4.9), *LHS* (left-hand side) = *RHS* (right-hand side), where

$$LHS = {}_c D_t^r (bf(t) + kg(t)). \quad (5.4.11)$$

By definition of the generalized derivative, with m and v as defined above,

$$LHS = D^m D^{-v} (bf(t) + kg(t)). \quad (5.4.12)$$

By definitions of D^m and D^{-v} ,

$$\begin{aligned} LHS &= d^m (d^{-v} (bf(t) + kg(t)) + \psi(bf + kg, -v)) + \psi(h, m) \\ &= d^m d^{-v} (bf(t) + kg(t)) + d^m \psi(bf + kg, -v) + \psi(h, m), \end{aligned} \quad (5.4.13)$$

where $h(t) = {}_a d_t^{-v} (bf(t) + kg(t))$.

Using the linearity of the fractional integral and the ordinary derivative

$$LHS = b d^m d^{-v} f(t) + k d^m d^{-v} g(t) + d^m \psi(bf(t) + kg(t), -v) + \psi(h, m). \quad (5.4.14)$$

For the *RHS* of equation (5.4.9),

$$RHS = b D^r f(t) + k D^r g(t) \quad (5.4.15)$$

and by definition of the generalized derivative

$$RHS = b D^m D^{-v} f(t) + k D^m D^{-v} g(t). \quad (5.4.16)$$

Now, by definitions of D^m and D^{-v} and rearranging terms,

$$RHS = b d^m d^{-v} f(t) + k d^m d^{-v} g(t) + b d^m \psi(f, -v) + k d^m \psi(g, -v) + b \psi(p, m) + k \psi(l, m), \quad (5.4.17)$$

where

$$p(t) = {}_a d_t^{-v} f(t), \quad \text{and} \quad l(t) = {}_a d_t^{-v} g(t). \quad (5.4.17a)$$

Therefore, linearity of the derivative requires $LHS = RHS$, then from equations (5.4.1.4) and (5.4.1.7),

$$d^m \psi(bf(t) + kg(t), -v) + \psi(h, m) = b d^m \psi(f, -v) + k d^m \psi(g, -v) + b \psi(p, m) + k \psi(l, m), \quad (5.4.18)$$

and requires satisfaction of equation (5.4.6), linearity of the fractional integral. Equation (5.4.6) can be differentiated to yield

$$d^m \psi(bf(t) + kg(t), -v) = b d^m \psi(f, -v) + k d^m \psi(g, -v), \quad t > c. \quad (5.4.19)$$

This result substituted into equation (5.4.18) gives the simpler requirement

$$\psi(h, m) = b \psi(p, m) + k \psi(l, m) \quad t > c, \quad (5.4.20)$$

for the fractional derivative.

The results (eq. (5.4.6) and (5.4.20)) apply in general, that is, for side charging. When constrained to terminal charging the conditions of equations (4.1.26) and (4.1.27) apply. Then the linearity requirement for the fractional integral becomes

$$\frac{1}{\Gamma(v)} \int_a^c (t-\tau)^{v-1} (bf(\tau) + kg(\tau)) d\tau = \frac{b}{\Gamma(v)} \int_a^c (t-\tau)^{v-1} f(\tau) d\tau + \frac{k}{\Gamma(v)} \int_a^c (t-\tau)^{v-1} g(\tau) d\tau, \quad (5.4.21)$$

and linearity is seen to hold for terminal charging. For the fractional derivative under terminal charging conditions, the results of equation (4.1.27) are applied to both sides of equation (5.4.20) to yield $0=0$, and again linearity holds for terminal charging.

5.5 Criterion 5: Composition

Composition or the index law requires proving that

$${}_c D_t^u {}_c D_t^v f(t) = {}_c D_t^v {}_c D_t^u f(t) = {}_c D_t^{u+v} f(t), \quad t > c. \quad (5.5.1)$$

The following cases apply:

Part 1: the fractional integral case u and $v < 0$,

Part 2: the tools needed for remaining parts, specifically

$${}_a D_t^q f(t) = {}_a D_t^1 {}_a D_t^{q-1} f(t) = {}_a D_t^{q-1} {}_a D_t^1 f(t) \text{ for } 1 > q > 0 \text{ and}$$

$${}_c D_t^m {}_c D_t^{-p} f(t) = {}_c D_t^{m-p} f(t) = {}_c D_t^{-p} {}_c D_t^m f(t) \text{ for } p > 0 \text{ and } m \geq 1 \text{ and an integer,}$$

Part 3: the fractional derivative case u and $v > 0$, and

Part 4: the mixed case with $u < 0$ and $v > 0$. These will be discussed below. The integral case will be considered first.

5.5.1 Part 1, Fractional Integration

For this part it is required to show that

$${}_c D_t^{-u} {}_c D_t^{-v} f(t) = {}_c D_t^{-u-v} f(t) = {}_c D_t^{-v} {}_c D_t^{-u}, \text{ for } u \geq 0, v \geq 0, t > c. \quad (5.5.1.1)$$

The left-hand side then can be written as

$$\begin{aligned} {}_c D_t^{-u} {}_c D_t^{-v} f(t) &= \frac{1}{\Gamma(u)} \int_c^t (t-\tau)^{u-1} \frac{1}{\Gamma(v)} \int_c^\tau (\tau-\tau_1)^{v-1} f(\tau_1) d\tau_1 d\tau + \\ &\quad \frac{1}{\Gamma(u)} \int_c^t (t-\tau)^{u-1} \psi(f, -v, a, c, \tau) d\tau + \psi(h, -u, a, c, t), \end{aligned} \quad (5.5.1.2)$$

where $h(t)$ is the input to (argument of) d^{-u} that would be active during the time period $a < t \leq c$. Namely, since the ψ 's are defined to be zero for $a < t \leq c$, $h(t) = {}_a d_t^{-v} f(t)$ for $a < t \leq c$ (refer to figure 5-5-1).

The case of terminal charging will be considered first; here, for $t > c$,

$$\psi(f, -v, a, c, t) = \frac{1}{\Gamma(v)} \int_a^c (t-\tau)^{v-1} f(\tau) d\tau$$

and

$$\psi(h, -u, a, c, t) = \frac{1}{\Gamma(u)} \int_a^c (t-\tau)^{u-1} \frac{1}{\Gamma(v)} \int_a^\tau (\tau-\tau_1)^{v-1} f(\tau_1) d\tau_1 d\tau. \quad (5.5.1.3)$$

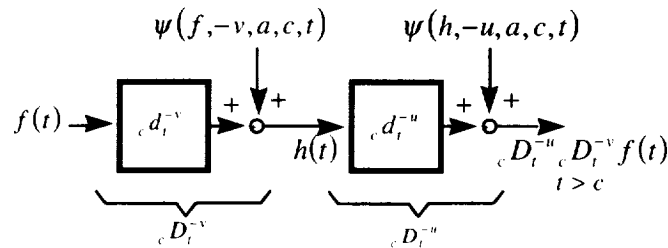

(a) During normal function

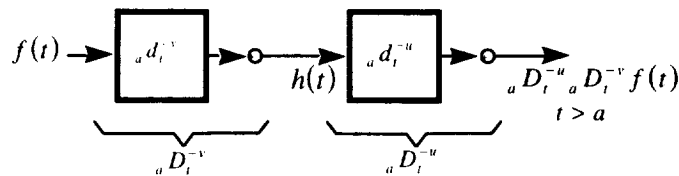

(b) During terminal charging - initialization

Figure 5-5-1.—Mathematical block diagram composition of fractional integrals (eq. (5.5.1.1) and (5.5.1.2)). (a) During normal function. (b) During terminal charging-initialization.

Now, for $f(t)$ continuous, the first integral in equation (5.5.1.2) is the uninitialized integral product. This is shown to be equal to the uninitialized composition by application of Dirichlet's formula (see Ross (1974); also repeated in Appendix A). Thus equation (5.5.1.2) becomes

$${}_c D_t^{-u} {}_c D_t^{-v} f(t) = {}_c d_t^{-u-v} f(t) + \frac{1}{\Gamma(u)\Gamma(v)} \int_a^t \int_a^c (t-\tau)^{u-1} (\tau-\tau_1)^{v-1} f(\tau_1) d\tau_1 d\tau + \frac{1}{\Gamma(u)\Gamma(v)} \int_a^t \int_a^\tau (t-\tau)^{u-1} (\tau-\tau_1)^{v-1} f(\tau_1) d\tau_1 d\tau. \quad (5.5.1.4)$$

Now working with the RHS and momentarily dropping the common integrands and $1/\Gamma\Gamma$'s

$$= {}_c d_t^{-u-v} f(t) + \int_a^t \int_a^c () d\tau_1 d\tau + \int_a^t \int_a^\tau () d\tau_1 d\tau. \quad (5.5.1.5)$$

As long as the integrand is unchanged over the appropriate ranges, the first integral may be partitioned as

$$= {}_c d_t^{-u-v} f(t) + \int_a^t \int_a^\tau () d\tau_1 d\tau + \int_a^t \int_\tau^c () d\tau_1 d\tau + \int_a^t \int_a^\tau () d\tau_1 d\tau. \quad (5.5.1.6)$$

Now the first and third integrals can be combined to give

$$= {}_c d_t^{-u-v} f(t) + \int_a^t \int_a^\tau () d\tau_1 d\tau + \int_a^t \int_\tau^c () d\tau_1 d\tau. \quad (5.5.1.7)$$

Replacing the integrands, the $1/\Gamma\Gamma$'s, and switching limits gives

$${}_c D_t^{-u} {}_c D_t^{-v} f(t) = {}_c d_t^{-u-v} f(t) + \frac{1}{\Gamma(u)\Gamma(v)} \int_a^t \int_a^\tau (t-\tau)^{u-1} (\tau-\tau_1)^{v-1} f(\tau_1) d\tau_1 d\tau - \frac{1}{\Gamma(u)\Gamma(v)} \int_a^t \int_c^\tau (t-\tau)^{u-1} (\tau-\tau_1)^{v-1} f(\tau_1) d\tau_1 d\tau. \quad (5.5.1.8)$$

Again, for $f(t)$ continuous, the Dirichlet formula and transformation may be applied as done above (and in Appendix A). Thus, the double integrals become

$$\begin{aligned} {}_c D_t^{-u} {}_c D_t^{-v} f(t) &= {}_c d_t^{-u-v} f(t) + \frac{1}{\Gamma(u+v)} \int_a^t (t-\tau)^{u+v-1} f(\tau) d\tau - \frac{1}{\Gamma(u+v)} \int_c^t (t-\tau)^{u+v-1} f(\tau) d\tau \\ &= {}_c d_t^{-u-v} f(t) + \frac{1}{\Gamma(u+v)} \int_a^c (t-\tau)^{u+v-1} f(\tau) d\tau = {}_c d_t^{-u-v} f(t) + \psi(f, -u-v, a, c, t) \\ {}_c D_t^{-u} {}_c D_t^{-v} f(t) &= {}_c D_t^{-u-v} f(t), \quad t > c, \end{aligned} \quad (5.5.1.9)$$

thus, completing the proof for composition of initialized fractional integrals with terminal charging.

When side charging conditions apply, if composition is required, that is,

$${}_c D_t^{-u-v} f(t) = {}_c D_t^{-u} {}_c D_t^{-v} f(t), \quad t > c, \quad (5.5.1.10)$$

then

$${}_c d_t^{-u-v} f(t) + \psi(f, -u-v, a, c, t) = \frac{1}{\Gamma(u)} \int_c^t (t-\tau)^{u-1} \frac{1}{\Gamma(v)} \int_c^\tau (\tau-\tau_1)^{v-1} f(\tau_1) d\tau_1 d\tau + \frac{1}{\Gamma(u)} \int_c^t (t-\tau)^{u-1} \psi(f, -v, a, c, \tau) d\tau + \psi(h, -u, a, c, t), \quad (5.5.1.11)$$

for $t > c$. Applying the Dirichlet formula and transformation (for continuous $f(t)$) shows the leading terms of both sides to be equal. This yields the following relation, which is required to satisfy equation (5.5.1.10)

$$\psi(f, -u-v, a, c, t) = \frac{1}{\Gamma(u)} \int_c^t (t-\tau)^{u-1} \psi(f, -v, a, c, \tau) d\tau + \psi(h, -u, a, c, t) \quad t > c. \quad (5.5.1.12)$$

5.5.2 Part 2, Mixed Generalized Integration and Integer Order Differentiation

The objective of this part is to prove that

$${}_c D_t^m {}_c D_t^{-p} f(t) = {}_c D_t^{-p} {}_c D_t^m f(t), \quad t > c, \quad (5.5.2.1)$$

for $p > 0$ and for m an integer $m \geq 1$. This is required to establish composition for the derivative.

Prior to the main goal of this part the following preliminary result required below is established. Consider the following derivative, for $1 > q > 0$, and $t > a$,

$${}_a D_t^q f(t) = {}_a D_t^1 {}_a D_t^{-(1-q)} f(t) = \frac{d}{dt} {}_a D_t^{-(1-q)} f(t), \quad (5.5.2.2)$$

by definition of the derivative. Now

$${}_a D_t^q f(t) = \frac{d}{dt} \frac{1}{\Gamma(1-q)} \int_a^t (t-\tau)^{-q} f(\tau) d\tau \quad (5.5.2.3)$$

by the definition of the fractional integral. Assuming $f(t)$ differentiable and applying integration by parts yields

$${}_a D_t^q f(t) = \frac{d}{dt} \left[\frac{(t-a)^{1-q} f(a)}{\Gamma(2-q)} + \frac{1}{\Gamma(2-q)} \int_a^t (t-\tau)^{1-q} f'(\tau) d\tau \right] \quad (5.5.2.4)$$

$$= \frac{d}{dt} \left[\frac{(t-a)^{1-q} f(a)}{\Gamma(2-q)} + {}_a D_t^{-(2-q)} f'(t) \right] \quad (5.5.2.5)$$

$$= D^1 {}_a D_t^{-(2-q)} D^1 f(t) + \frac{(1-q)(t-a)^{-q} f(a)}{\Gamma(2-q)}. \quad (5.5.2.6)$$

By part 1, equation (5.5.1.9),

$${}_a D_t^q f(t) = D^1 {}_a D_t^{-1} {}_a D_t^{-(1-q)} D^1 f(t) + \frac{(t-a)^{-q} f(a)}{\Gamma(1-q)}. \quad (5.5.2.7)$$

Then, for $1 > q > 0$ and for $f(t)$ differentiable, equation (5.5.2.2) may be written as

$${}_a D_t^q f(t) = {}_a D_t^1 D_t^{q-1} f(t) = {}_a D_t^{-(1-q)} {}_a D_t^1 f(t) + \frac{(t-a)^{-q} f(a)}{\Gamma(1-q)}. \quad (5.5.2.8)$$

Under the condition that $f(t) = 0 \forall t \leq a$ the last term is zero and for $1 > q > 0, t > a$

$$\boxed{{}_a D_t^q f(t) = {}_a D_t^1 D_t^{q-1} f(t) = {}_a D_t^{q-1} {}_a D_t^1 f(t).} \quad (5.5.2.9)$$

as the final result. Note, this equation holds from left to right, but right to left fails when ${}_a D_t^1 f(t) = 0$ or $f(t) = \text{constant}$. This completes the preliminary aspect.

Again, to establish composition for the derivative it is required to prove equation (5.5.2.1), that is, the mixed case of integer order differentiation and fractional integration

$${}_c D_t^m {}_c D_t^{-p} f(t) = {}_c D_t^{-p} {}_c D_t^m f(t), \quad t > c, \quad (5.5.2.10)$$

for $p > 0$ and for m an integer $m \geq 1$.

This requires that

$$\begin{aligned} {}_c d_t^m ({}_c d_t^{-p} f(t) + \psi(f, -p, a, c, t)) + \psi(h, m, a, c, t) = \\ {}_c d_t^{-p} ({}_c d_t^m f(t) + \psi(f, m, a, c, t)) + \psi(g, -p, a, c, t), \quad \text{for } t > c, \end{aligned} \quad (5.5.2.11)$$

where $h(t) = {}_a D_t^{-p} f(t)$ and $g(t) = {}_a D_t^m f(t)$. For the case of terminal charging, it has been shown that $\psi(h, m, a, c, t) = 0$ and $\psi(f, m, a, c, t) = 0$ for the integer differentiations. Substituting the terminal charging ψ 's for the fractional integrals gives

$$\begin{aligned} \frac{d^m}{dt^m} \left(\frac{1}{\Gamma(p)} \int_c^t (t-\tau)^{p-1} f(\tau) d\tau + \frac{1}{\Gamma(p)} \int_a^c (t-\tau)^{p-1} f(\tau) d\tau \right) = \\ \frac{1}{\Gamma(p)} \int_c^t (t-\tau)^{p-1} \frac{d^m}{d\tau^m} f(\tau) d\tau + \frac{1}{\Gamma(p)} \int_a^c (t-\tau)^{p-1} \frac{d^m}{d\tau^m} f(\tau) d\tau, \quad \text{for } t > c. \end{aligned} \quad (5.5.2.12)$$

Now, combining integrals of like integrands

$$\frac{d^m}{dt^m} \left(\frac{1}{\Gamma(p)} \int_a^t (t-\tau)^{p-1} f(\tau) d\tau \right) = \frac{1}{\Gamma(p)} \int_a^t (t-\tau)^{p-1} \frac{d^m}{d\tau^m} f(\tau) d\tau, \quad \text{for } t > c \quad (5.5.2.13)$$

or

$${}_a D_t^m {}_a D_t^{-p} f(t) = {}_a D_t^{-p} {}_a D_t^m f(t). \quad (5.5.2.14)$$

This conforms precisely to the uninitialized case, which now must be proved to establish the initialized case.

The proof is started with the LHS of equation (5.5.2.14). Since for the uninitialized case all ψ 's = 0 this may be written as

$${}_a D_t^m {}_a D_t^{-p} f(t) = {}_a D_t^m \frac{1}{\Gamma(p)} \int_a^t (t-\tau)^{p-1} f(\tau) d\tau. \quad (5.5.2.15)$$

Integrating by parts m times gives

$$= {}_a D_t^m \left[\sum_{k=0}^{m-1} \frac{f^{(k)}(a)(t-a)^{p+k}}{\Gamma(p+k+1)} + {}_a D_t^{-(p+m)} f^{(m)}(t) \right]. \quad (5.5.2.16)$$

By definition $f(t) = 0 \quad \forall t \leq a$ thus $f^{(k)}(a) = 0$ for all k , therefore

$$= {}_a D_t^m {}_a D_t^{-(p+m)} {}_a D_t^m f(t) \quad (5.5.2.17)$$

since $p > 0, m \geq 1$, then $p+m \geq m \geq 1$. Let $g(t) = {}_a D_t^m f(t)$ be a non-zero continuous function of t . Then since the integral limits a and t are differentiable functions of t , and since $t - \tau \geq 0$ and $p+m-1 \geq 0$ then $(t-\tau)^{p+m-1} g(\tau)$ and its partial derivative with respect to t are continuous in both t and τ . Thus Leibnitz's rule may be applied to give

$$\begin{aligned} = {}_a D_t^m {}_a D_t^{-(p+m)} g(t) &= \frac{d^{m-1}}{dt^{m-1}} \left[\frac{1}{\Gamma(p+m)} \int_a^t \frac{\partial}{\partial t} (t-\tau)^{p+m-1} g(\tau) d\tau + (t-\tau)^{p+m-1} g(\tau) \Big|_{\tau=t} \right] \\ &= \frac{d^{m-1}}{dt^{m-1}} {}_a D_t^{-(p+m-1)} g(t). \end{aligned} \quad (5.5.2.18)$$

Under similar conditions Leibnitz's rule may be applied a total of m times. The non-integral term will always be 0 by the above argument, thus

$${}_a D_t^m {}_a D_t^{-p} f(t) = \frac{d^0}{dt^0} {}_a D_t^{-(p+m-m)} g(t) = {}_a D_t^{-p} {}_a D_t^m f(t) \quad (5.5.2.19)$$

proving equations (5.5.2.14) and thus, equation (5.5.2.1) for $t > c$, by definition of ${}_c D_t^q f(t)$.

To establish composition of mixed differintegrals it is also required to prove that for $t > c$

$${}_c D_t^m {}_c D_t^{-p} f(t) = {}_c D_t^{m-p} f(t) \quad (5.5.2.20a) \quad \text{and} \quad {}_c D_t^{-p} {}_c D_t^m f(t) = {}_c D_t^{m-p} f(t). \quad (5.5.2.20b)$$

For equation (5.5.2.20a) two cases are considered:

Case 1: $p > m$

Then under the conditions of terminal charging the LHS of equation (5.5.2.20a) becomes

$${}_c D_t^m {}_c D_t^{-p} f(t) = \frac{d^m}{dt^m} \left[\frac{1}{\Gamma(p)} \int_c^t (t-\tau)^{p-1} f(\tau) d\tau + \frac{1}{\Gamma(p)} \int_a^c (t-\tau)^{p-1} f(\tau) d\tau \right]. \quad (5.5.2.21)$$

Now, $p > m \geq 1$, therefore, $p-1 \geq 0$ and since $t - \tau \geq 0$, the integrand $(t-\tau)^{p-1} f(\tau)$ and its partial derivative with respect to t is continuous in both t and τ , provided $f(t)$ is continuous.

Then Leibnitz's Rule may be applied to the combined integral of equation (5.5.2.21) to give

$$= \frac{d^{m-1}}{dt^{m-1}} \int_a^t \frac{\partial}{\partial t} (t-\tau)^{p-1} f(\tau) d\tau \quad (5.5.2.22)$$

or

$$= \frac{d^{m-1}}{dt^{m-1}} \frac{(p-1)}{\Gamma(p)} \int_a^t (t-\tau)^{p-2} f(\tau) d\tau = \frac{d^{m-1}}{dt^{m-1}} {}_a D_t^{-(p-1)} f(t). \quad (5.5.2.23)$$

Since $p > m$, continuity will be satisfied and this process may be repeated for a total of m times, yielding

$$= \frac{d^0}{dt^0} {}_a D_t^{-(p-m)} f(t) = {}_a D_t^{m-p} f(t). \quad (5.5.2.24)$$

Now for $t > c$, ${}_a D_t^{m-p} f(t) = {}_c D_t^{m-p} f(t)$, which completes the case 1 ($p > m$) part of the proof.

Case 2: $p < m$

For terminal charging

$${}_c D_t^m {}_c D_t^{-p} f(t) = \frac{d^m}{dt^m} \left[\frac{1}{\Gamma(p)} \int_c^t (t-\tau)^{p-1} f(\tau) d\tau + \frac{1}{\Gamma(p)} \int_a^c (t-\tau)^{p-1} f(\tau) d\tau \right]. \quad (5.5.2.25)$$

Now assume $m - p > 1$, (i.e., derivative of higher order than integral). Further, assume there exists some generalized derivative of order v such that $v = n - q = m - p$, namely,

$${}_c D_t^v f(t) = {}_c D_t^n {}_c D_t^{-q} f(t), \quad t > c, \quad (5.5.2.26)$$

where n is the least integer greater than q and $0 < q \leq 1$. Now, under the same continuity requirements as above Leibnitz's rule may be applied to the RHS of equation (5.5.2.25) to obtain

$${}_c D_t^m {}_c D_t^{-p} f(t) = \frac{d^{m-1}}{dt^{m-1}} \frac{(p-1)}{\Gamma(p)} \int_a^t (t-\tau)^{(p-1)-1} f(\tau) d\tau \quad (5.5.2.27)$$

$$= \frac{d^{m-1}}{dt^{m-1}} {}_a D_t^{-(p-1)} f(t). \quad (5.5.2.28)$$

Repeat the process b total times, where $0 < p - b < 1$, to obtain

$$= \frac{d^{m-b}}{dt^{m-b}} {}_a D_t^{-(p-b)} f(t). \quad (5.5.2.29)$$

Let $q = p - b$ then $m - b = m + q - p = n$ yielding

$$= {}_a D_t^n {}_a D_t^{-q} f(t) = {}_a D_t^v f(t) = {}_c D_t^v f(t), \quad \text{for } t > c, \quad (5.5.2.30)$$

thus proving the existence of the derivative and the $m - p > 1$ case.

Now, if $m - p \leq 1$, then $m - 1 \leq p$, but by hypothesis for case 2, $0 < p < m$ thus

$$m - 1 \leq p < m,$$

hence m is the least integer greater than p therefore ${}_c D_t^m {}_c D_t^{-p} f(t)$ is by definition the generalized derivative ${}_c D_t^v f(t)$. Thus,

$${}_c D_t^m {}_c D_t^{-p} f(t) = {}_c D_t^{m-p} f(t) \quad (5.5.2.31)$$

is proven, completing consideration of equation (5.5.2.20a).

Equation (5.5.2.20b) is now considered

$${}_c D_t^{-p} {}_c D_t^m f(t) = {}_c D_t^{m-p} f(t). \quad (5.5.2.32)$$

Then for terminal charging and $t > c \geq a$,

$${}_c D_t^{-p} {}_c D_t^m f(t) = {}_a D_t^{-p} {}_a D_t^m f(t) = \frac{1}{\Gamma(p)} \int_a^t (t-\tau)^{p-1} \frac{d^m}{d\tau^m} f(\tau) d\tau. \quad (5.5.233)$$

As above, two cases are considered.

Case 1: $p > m \geq 1$

Applying integration by parts, for $f(t)$ being m -times differentiable and $f^{(m)} \neq 0$, gives

$$= \frac{(t-\tau)^{p-1}}{\Gamma(p)} \frac{d^{m-1} f(\tau)}{d\tau^{m-1}} \Big|_a^t + \frac{(p-1)}{\Gamma(p)} \int_a^t (t-\tau)^{p-2} \frac{d^{m-1}}{d\tau^{m-1}} f(\tau) d\tau. \quad (5.5.234)$$

Since $p > 1$, this evaluates to

$$= -\frac{(t-a)^{p-1}}{\Gamma(p)} f^{(m-1)}(a) + {}_a D_t^{-(p-1)} \frac{d^{m-1}}{dt^{m-1}} f(t). \quad (5.5.235)$$

For $f(t)$, m -times differentiable, and since $p > m \geq 1$, the process may be successfully repeated a total of m times to get

$${}_a D_t^{-p} {}_a D_t^m f(t) = {}_a D_t^{-(p-m)} f(t) - \sum_{k=1}^m \frac{(t-a)^{p-k} f^{(m-k)}(a)}{\Gamma(p-k-1)}. \quad (5.5.236)$$

Since by definition $f(t) = 0 \quad \forall t \leq a$, thus $f^{(m-k)}(a) = 0$ for all k , and case 1 ($p > m \geq 1$) is complete.

Case 2: $m > p > 0$ and $m \geq 1$

Again, for terminal charging and $t > c \geq a$,

$${}_c D_t^{-p} {}_c D_t^m f(t) = {}_a D_t^{-p} {}_a D_t^m f(t) = \frac{1}{\Gamma(p)} \int_a^t (t-\tau)^{p-1} \frac{d^m}{d\tau^m} f(\tau) d\tau. \quad (5.5.237)$$

Again, for $f(t)$ being m -times differentiable and $f^{(m)} \neq 0$, integration by parts may be successfully applied k times where k is an integer such that $k+1 > p > k \geq 1$, that is, $p-k > 0$ then,

$${}_a D_t^{-p} {}_a D_t^m f(t) = {}_a D_t^{-(p-k)} {}_a D_t^{m-k} f(t) - \sum_{j=1}^k \frac{(t-a)^{p-j} f^{(m-j)}(a)}{\Gamma(p-j-1)} \quad (5.5.238)$$

and because $f(t) = 0, \forall t \leq a$, the summation terms of equation (5.5.238) analysis are zero.

Now $1 > p-k > 0$, and since $m > p$, $m-k > 0$ and is an integer. Let $r = p-k$, then the integer order derivative can be rewritten as

$${}_a D_t^{-p} {}_a D_t^m f(t) = {}_a D_t^{-r} {}_a D_t^1 {}_a D_t^{m-k-1} f(t). \quad (5.5.239)$$

Then, since $1 > r > 0$, using the preliminary result, equation (5.5.2.9) gives, provided ${}_a D_t^{m-k-1} f(t) \neq 0$,

$${}_a D_t^{-p} {}_a D_t^m f(t) = {}_a D_t^1 {}_a D_t^{-r} {}_a D_t^{m-k-1} f(t) \quad (5.5.2.40)$$

$$= {}_a D_t^1 {}_a D_t^{-r} {}_a D_t^1 {}_a D_t^{m-k-2} f(t) \quad \text{integer order derivatives} \quad (5.5.2.41)$$

$$= {}_a D_t^1 {}_a D_t^1 {}_a D_t^{-r} {}_a D_t^{m-k-2} f(t) \quad \text{by (5.5.2.9)} \quad (5.5.2.42)$$

$$= {}_a D_t^2 {}_a D_t^{-r} {}_a D_t^{m-k-2} f(t) \quad \text{integer order derivatives.} \quad (5.5.2.43)$$

Repeating the last four steps a total of $m-k$ times gives

$$= {}_a D_t^{m-k} {}_a D_t^{-r} f(t) \quad (5.5.2.44)$$

$$= {}_a D_t^{m-k-r} f(t) \quad \text{by (5.5.2.31)} \quad (5.5.2.45)$$

$$= {}_a D_t^{m-p} f(t), \quad t > c. \quad (5.5.2.46)$$

Since ${}_a D_t^{m-p} f(t) = {}_c D_t^{m-p} f(t)$, for $t > c$, then equation (5.5.2.32) is true and equation (5.5.2.20b) is validated. This completes the terminal charging case.

For the more general case of side charging the equation

$$\begin{aligned} {}_c d_t^m ({}_c d_t^{-p} f(t) + \psi(f, -p, a, c, t)) + \psi(h, m, a, c, t) = \\ {}_c d_t^{-p} ({}_c d_t^m f(t) + \psi(f, m, a, c, t)) + \psi(g, -p, a, c, t) \quad \text{for } t > c \end{aligned} \quad (5.5.2.47)$$

must be used directly as the authors have not found a stronger condition as of this writing.

Some special cases may be considered here. Case A is terminal charging of the fractional integrators with side charging of the differentiators. After appropriate substitutions and combining integrals in equation (5.5.2.47)

$$\begin{aligned} \frac{d^m}{dt^m} \frac{1}{\Gamma(p)} \int_a^t (t-\tau)^{p-1} f(\tau) d\tau + \psi(h, m, a, c, t) = \\ \frac{1}{\Gamma(p)} \int_a^t (t-\tau)^{p-1} f^{(m)}(\tau) d\tau + \frac{1}{\Gamma(p)} \int_c^t (t-\tau)^{p-1} \psi(f, m, a, c, \tau) d\tau, \quad t > c. \end{aligned} \quad (5.5.2.48)$$

Then with the assumption that $f^{(k)}(a) = 0$ for all k , the following requirement is obtained

$$\begin{aligned} \psi(h, m, a, c, t) = {}_a d_t^{-p} {}_c d_t^m f(t) - {}_c d_t^m {}_a d_t^{-p} f(t) + {}_a d_t^{-p} \psi(f, m, a, c, t) = \\ {}_a d_t^{-p} \psi(f, m, a, c, t), \quad t > c. \end{aligned} \quad (5.5.2.49)$$

For the reverse case B, which is terminal charging of the differentiators and side charging of the fractional integrators, the requirement is

$$\begin{aligned} \psi(g, -p, a, c, t) = \frac{d^m}{dt^m} \psi(f, -p, a, c, t) + \frac{d^m}{dt^m} {}_c d_t^{-p} f(t) - {}_c d_t^{-p} f^{(m)}(t) = \\ \frac{d^m}{dt^m} \psi(f, -p, a, c, t), \quad t > c. \end{aligned} \quad (5.5.2.50)$$

5.5.3 Part 3, Fractional Differentiation

The requirement for fractional differentiation is to show, for $t > c$,

$${}_c D_t^u {}_c D_t^v f(t) = {}_c D_t^v {}_c D_t^u f(t) = {}_c D_t^{u+v} f(t), \quad \text{for } u > 0, v > 0. \quad (5.5.3.1)$$

Then by definition of the derivative and setting $u = m - p$ and $v = n - q$ with m and n the least integers greater than p and q respectively and with $0 < p \leq 1$, and $0 < q \leq 1$ we have

$${}_c D_t^u {}_c D_t^v f(t) = {}_c D_t^{m-p} {}_c D_t^{n-q} f(t). \quad (5.5.3.2)$$

By definition of the derivative

$${}_c D_t^u {}_c D_t^v f(t) = {}_c D_t^m {}_c D_t^{-p} {}_c D_t^n {}_c D_t^{-q} f(t) \quad (5.5.3.3)$$

$$= {}_c D_t^m {}_c D_t^{-p} {}_c D_t^n g(t), \quad (5.5.3.4)$$

where $g(t) = {}_c D_t^{-q} f(t)$. From part 2 for terminal charging and since $g(t) = 0, \forall t \leq a$, the $-p$ and n differintegrals may be interchanged, thus

$${}_c D_t^u {}_c D_t^v f(t) = {}_c D_t^m {}_c D_t^n {}_c D_t^{-p} g(t) \quad (5.5.3.5)$$

$$= {}_c D_t^{m+n} {}_c D_t^{-(p+q)} f(t). \quad (5.5.3.6)$$

If $p + q < 1$, then the definition of the derivative is satisfied and

$${}_c D_t^u {}_c D_t^v f(t) = {}_c D_t^{u+v} f(t). \quad (5.5.3.7)$$

However, by definition of the derivatives in equation (5.5.2.16), $p + q \leq 2$, therefore if $p + q \geq 1$, then for $f(t)$ continuous, $(t - \tau)^{p+q-1} f(\tau)$ and its partial derivative with respect to t are continuous and we may apply Leibnitz's rule to the integral to give

$${}_c D_t^{m+n-1} {}_c D_t^{-(p+q-1)} f(t) = {}_c D_t^{u+v} f(t), \quad t > c, \quad (5.5.3.8)$$

since the definition of the derivative now applies. Thus, for the terminal charging condition, for differintegrals initialized at $t = c$, the index law holds true for both differentiation and integration.

For the more general case of side charging, the most general situation allows all of the ψ 's to be arbitrary. Therefore to satisfy

$${}_c D_t^u {}_c D_t^v f(t) = {}_c D_t^{u+v} f(t), \quad \text{for } u > 0, v > 0 \quad (5.5.3.9)$$

with ${}_c D_t^{u+v} f(t) = {}_c d_t^{u+v} f(t) + \psi(f, u+v)$ requires the following relationship:

$$d^{u+v} f(t) + \psi(f, u+v) =$$

$$d^m d^{-p} d^n d^{-q} f(t) + d^m d^{-p} d^n \psi(f, -q) +$$

$$d^m d^{-p} \psi(h, n) + d^m \psi(j, -p) + \psi(l, m) \quad \text{for } t > c, \quad (5.5.3.10)$$

where all ψ 's are arbitrary and $h(t)$, $j(t)$, and $l(t)$ are defined as

$$\begin{aligned} h(t) &= {}_c D_t^{-q} f(t), \\ j(t) &= {}_c D_t^n {}_c D_t^{-q} f(t), \\ \text{and } l(t) &= {}_c D_t^{-p} {}_c D_t^n {}_c D_t^{-q} f(t). \end{aligned} \tag{5.5.3.11}$$

This is shown in block diagram form in figure 5-5-2. From the results of equations (5.5.3.7) and (5.5.3.8), specialized to the uninitialized case the first terms on each side of equation (5.5.3.10) are equal thus the general side charging requirement becomes

$$\psi(f, u+v) = d^m d^{-p} d^n \psi(f, -q) + d^m d^{-p} \psi(h, n) + d^m \psi(j, -p) + \psi(l, m) \text{ for } t > c \tag{5.5.3.12}$$

where the c, t subscripts and a, c, t parts of the arguments have been dropped for convenience.

Again, special cases may be considered. Terminal charging of the fractional integrators and side charging of the differentiators, allows $\psi(f, -q) = {}_a d_c^{-q} f(t)$ and $\psi(j, -p) = {}_a d_c^{-p} \{ {}_a d_c^{-q} f(t) + \psi(h, n) \}$ to be substituted into equation (5.5.3.12). Similarly, terminal charging of the differentiators and side charging of the fractional integrators allows $\psi(l, m, a, c, t) = 0$ and $\psi(h, n, a, c, t) = 0$, in equations (5.5.3.10) and (5.5.3.12) above.

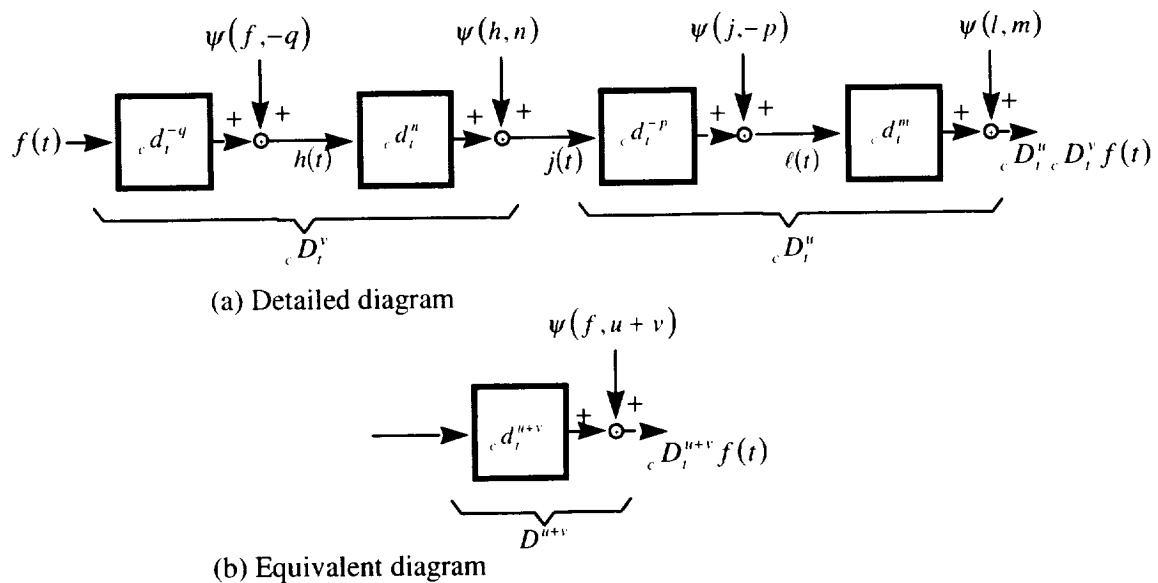

Figure 5-5-2.—Mathematical block diagram for composition of fractional derivatives (eq. (5.5.3.9) and (5.5.3.10)). (a) Detailed diagram. (b) Equivalent diagram.

5.5.4 Part 4, Mixed Integration and Differentiation

It still remains to prove the general mixed case

$${}_c D_t^u {}_c D_t^{-v} f(t) = {}_c D_t^{-v} {}_c D_t^u f(t) = {}_c D_t^{u-v} f(t), \quad t > c, \quad (5.5.4.1)$$

for $u > 0$ and $v > 0$.

For the case of terminal charging, let $u = m - p$ where $0 \leq p \leq 1$ and $m \geq 1$ and an integer, then using part 1 results the LHS becomes

$${}_c D_t^u {}_c D_t^{-v} f(t) = {}_c D_t^m {}_c D_t^{-p} {}_c D_t^{-v} f(t) = {}_c D_t^m {}_c D_t^{-(p+v)} f(t). \quad (5.5.4.2)$$

Now, under the conditions allowing part 2, this becomes

$$= {}_c D_t^{-(p+v)} {}_c D_t^m f(t) \quad (5.5.4.3)$$

$$= {}_c D_t^{-v} {}_c D_t^{-p} {}_c D_t^m f(t) \quad (5.5.4.4)$$

$$= {}_c D_t^{-v} {}_c D_t^u f(t). \quad (5.5.4.5)$$

This proves the first equality in equation (5.5.4.1). Now, from equation (5.5.4.3) with $v + p \geq 0$ therefore, using part 2 results this gives,

$${}_c D_t^u {}_c D_t^{-v} f(t) = {}_c D_t^{m-(v+p)} f(t) = {}_c D_t^{u-v} f(t), \quad t > c, \quad (5.5.4.6)$$

completing part 4. This completes criterion 5.

5.5.5 Comments on Criteria

The totality of parts 1, 3 and 4 of criterion 5 above combine to give the following result. Under the conditions of terminal charging of the u th and v th differintegrals

$${}_c D_t^u {}_c D_t^v f(t) = {}_c D_t^v {}_c D_t^u f(t) = {}_c D_t^{u+v} f(t) \quad \text{for } t > c \quad (5.5.5.1)$$

under the following conditions:

- (1) $u < 0, v < 0$ for $f(t)$ continuous
- (2) $u > 0, v > 0$ $f(t)$ is m -times differentiable, ${}_c D_t^m f(t)$ exists and is a non-zero continuous function of $t, t > a$, where m an integer is the larger of $\text{Int}[u]$ or $\text{Int}[v]$.
- (3) $u < 0, v > 0$ same as (2).

We now discuss the basic criteria results derived above for a generalized (fractional) calculus. The scope of this work was limited to the real domain. Attention will first be focused on the terminal charging case.

Terminal Charging

Relative to criterion 2, backward compatibility with the integer order calculus, the addition of the initialization function is clearly a generalization relative to the integer order calculus. In a strict sense $\psi(t) \neq 0$ violates criterion 2, however we are seeking a generalization of the integer order calculus and it is clear that this generalization (i.e., the formal addition of an initialization function) will be very useful in many applications.

Relative to criterion 3 the zero order property holds for terminal charging.

Relative to criterion 4 linearity holds for the terminally charged case.

Relative to criterion 5, composition holds for terminal charging subject to the constraints noted in equation (5.5.5.1). It is noted that the constraint, $f^{(k)}(c) = 0 \forall k$, no longer exists, which satisfies a primary objective of this work. This constraint has effectively been contained in (shifted to) the requirement $f(t) = 0, \forall t \leq a$. This allows practical initialization for fractional differential equations.

In summary, the terminal charging case is backward compatible with the integer order calculus and satisfies the applicable criteria established by Ross for a fractional calculus.

Side Charging

The state of affairs with regard to side charging is less definitive. Criterion 2, backward compatibility, is the same as the terminal charging case since the ψ 's are arbitrary.

Relative to the zero property criterion 3, the conditions that

$$\psi(f, -p, a, c, t) = \frac{1}{\Gamma(p)} \int_a^c (t - \tau)^{p-1} f(\tau) d\tau \quad \text{and} \quad \psi(h, m, a, c, t) = 0, \quad (5.5.5.2)$$

are not required for side charging. When these conditions are not met, the zero order operation on $f(t)$ will return $f(t) + g(t)$, that is, the original function with an "extra" time function ($g(t)$), the effect of the initializations. At first reading this may appear somewhat bizarre, however, this is of benefit (realizable) in analyzing certain physical systems. This will be demonstrated in the applications section of this paper (see for example the generalized zero order operator), and the reader is requested to reserve judgment until that point.

Relative to criterion 4, linearity for the side charging case, demands the requirements of equation (5.4.6) or equations (5.4.18) and/or (5.4.20).

Relative to criterion 5, composition for the side charged case additionally requires the satisfaction of equation (5.5.1.1.2) for fractional integration, equation (5.5.2.47) for mixed generalized integration and integer order differentiation, and equation (5.5.3.12) for generalized differentiation. It is noted that with equality of the leading terms on the two sides of equation (5.5.2.47) the requirement is simplified to

$${}_c d_t^m \psi(f, -p) + \psi(h, m) = {}_c d_t^{-p} \psi(f, m) + \psi(g, -p). \quad (5.5.5.3)$$

These are not so much of an issue as first appears for practical application. In the solution, for example, of fractional differential equations, $\psi(t)$ will be chosen in much the same manner as initial conditions are currently chosen for ODE's or for PDE's. This will imply the nature of $f(t)$ for $a \leq t \leq c$. The new aspect is that to achieve a particular initialization for a given composition now requires attention to the initializations of the composing elements. That is, the requirements derived above must be used to determine the new initialization.

6. Laplace Transforms of Generalized Differintegrals

In this section general forms will be derived for the Laplace transform of fractional derivatives and integrals. The derived forms should be generalizations of those available for use with ordinary (integer) differential equations and will include the effects of the initialization functions for the fractional differintegrals.

6.1 Preliminaries

It is useful to consider the following two simple cases before attempting general results. Based on the integer order calculus, when $f(t)$ is piecewise regular and of exponential order, the Laplace transform of $\int_b^t f(t)dt$ is given by

$$L\left\{\int_b^t f(t)dt\right\} = \frac{1}{s} L\{f(t)\} + \frac{1}{s} \int_b^0 f(t)dt \quad (6.11)$$

(see e.g., Wylie (1975) p. 265). Contrast this to the generalized calculus case for the same integral,

$$L\left\{{}_b D_t^{-1} f(t)\right\} = L\left\{\int_b^t f(t)dt + \psi(f, -1, a, b, t)\right\}. \quad (6.12)$$

If equation (6.1.1) is used to evaluate the transform, we have

$$L\left\{{}_b D_t^{-1} f(t)\right\} = \frac{1}{s} L\{f(t)\} + \frac{1}{s} \int_b^0 f(t)dt + L\left\{\psi(f, -1, a, b, t)\right\}. \quad (6.13)$$

However, in the most general case ψ is arbitrary, if it is chosen as $\psi = const$ then since

$$L\{const\} = \frac{const}{s}, \quad (6.14)$$

it is clear that this term contains the initializing effect of the second term on the RHS of equation (6.1.3). Hence it is not necessary to include such terms that redundantly bring in the effect of initialization from the integer calculus. Thus,

$$L\{ {}_b D_t^{-1} f(t) \} = \frac{1}{s} L\{ f(t) \} + L\{ \psi(f, -1, a, b, t) \}. \quad (6.1.5)$$

Consider now the integer derivative. Based on the integer order calculus under appropriate conditions (see Wylie (1975) p. 264) the Laplace transform of $f'(t)$ is given by

$$L\{ f'(t) \} = sL\{ f(t) \} - f(0^+). \quad (6.1.6)$$

Contrast this to the generalized calculus case for the same derivative

$$L\{ {}_0 D_t^1 f(t) \} = L\left\{ \frac{d f(t)}{dt} + \psi(f, 1, a, 0, t) \right\}. \quad (6.1.7)$$

If equation (6.1.6) is used to evaluate the derivative in equation (6.1.7), the following is obtained:

$$L\{ {}_0 D_t^1 f(t) \} = sL\{ f(t) \} - f(0^+) + L\{ \psi(f, 1, a, 0, t) \}. \quad (6.1.8)$$

Again in the most general case ψ is arbitrary, if it is chosen as $\psi = -f(t)\delta(t - 0^+)$, then, since

$$L\{ -f(t)\delta(t - 0^+) \} = -f(0^+) \quad (6.1.9)$$

(see e.g., Gabel and Roberts (1973) pp. 72-77) it is clear that this term contains the initializing effect brought in by the integer order calculus term. Again it is not necessary to include such redundant terms.

The redundant terms are introduced into the above equations by the product term of the *integration by parts* formula, which is applied in deriving the reference equations in the integer order calculus. In the subsections that follow, these redundancies will be eliminated without hesitation when it is appropriate to do so.

In the material that follows, considering discontinuities at $t = 0$, evaluations stated as $t = 0$ will be understood to be evaluated at $t = 0^+$, consistent with the conventional definition for the Laplace transform (Wylie (1975)).

6.2 Laplace Transform of Fractional Integrals

For simplicity the starting point is taken as $c = 0$. Thus it is desired to evaluate

$$L\{ {}_0 D_t^{-q} f(t) \} = \int_0^{\infty} e^{-st} \left(\int_0^t \frac{(t-\tau)^{q-1}}{\Gamma(q)} f(\tau) d\tau + \psi(f, -q, a, 0, t) \right) dt \quad q > 0, t > 0. \quad (6.2.1)$$

The convolution theorem for the Laplace transform (Churchill (1958)) may be applied if $H(s)$ and $G(s)$ are transforms of $h(t)$ and $g(t)$, which are sectionally continuous functions and are of exponential order as $t \rightarrow \infty$. Then the convolution $h(t)*g(t)$ exists and is defined as

$$h(t)*g(t) = \int_0^t h(\tau)g(t-\tau)d\tau \quad (6.2.2)$$

and

$$L(h(t)*g(t)) = H(s)G(s) = L\left(\int_0^t h(\tau)g(t-\tau)d\tau\right). \quad (6.2.3)$$

Then taking $h(t) = f(t)$ and $g(t) = \frac{t^{q-1}}{\Gamma(q)}$ the convolution theorem (for eq. (6.2.1)) yields

$$F(s)G(s) = L(f(t))L\left(\frac{t^{q-1}}{\Gamma(q)}\right) = \frac{1}{s^q}L(f(t)) \quad q > 0. \quad (6.2.4)$$

This yields the general result,

$$L({}_0D_t^{-q}f(t)) = \frac{1}{s^q}L(f(t)) + L(\psi(f, -q, a, 0, t)), \quad q > 0. \quad (6.2.5)$$

Now in equation (6.2.5), $\psi(f, -q, a, 0, t)$ may be thought of as the composed (equivalent) effect of the initializations of the mathematical elements used to create ${}_0D_t^{-q}f(t)$. For the fractional order case there are infinitely many ways ${}_0D_t^{-q}f(t)$ may be composed, as opposed to the integer order calculus case where only combinations of integer order integrations are possible. For example, in the integer order calculus, the familiar Laplace transform,

$$L\{f^{(n)}(t)\} = s^n F(s) - s^{n-1}f(0+) - s^{n-2}f'(0+) \dots - f^{(n-1)}(0+), \quad (6.2.6)$$

infers that $f^{(n)}(t)$ is composed of (or decomposed into) n separate differentiations each of order 1.

6.2.1 Integer Order Decomposition of Fractional Integral

It is clear that the composition law must be satisfied to achieve equivalent initialization functions. Further, so long as only generalized integration is considered, composition is satisfied (eq. (5.5.5.1)).

As an example decomposition, the following is obtained through integration by parts; for $q > 1$, consider

$$L(\psi(f, -q, a, 0, t)) = \int_0^\infty e^{-st}\psi(f, -q, a, 0, t)dt. \quad (6.2.1.1)$$

Now integrating by parts, with

$$u = \psi(f, -q, a, 0, t), \quad dv = e^{-st} dt, \quad (6.2.1.2)$$

then

$$du = \frac{d}{dt} \psi(f, -q, a, 0, t) dt, \quad v = \frac{e^{-st}}{-s}, \quad (6.2.1.3)$$

and with $\frac{d\psi}{dt} = \psi^{(1)}$ yields

$$L(\psi(f, -q, a, 0, t)) = \left(\frac{e^{-st}}{-s} \psi(f, -q, a, 0, t) \right) \Big|_0^\infty + \frac{1}{s} \int_0^\infty e^{-st} \psi^{(1)}(f, -q, a, 0, t) dt \quad (6.2.1.4)$$

or

$$L(\psi(f, -q, a, 0, t)) = 0 + \frac{1}{s} \psi(f, -q, a, 0, t) \Big|_{t=0} + \frac{1}{s} L(\psi^{(1)}(f, -q, a, 0, t)). \quad (6.2.1.5)$$

Repeating this process gives

$$L(\psi(f, -q, a, 0, t)) = \frac{1}{s} \psi(f, -q, a, 0, t) \Big|_{t=0} + \frac{1}{s} \left(\frac{1}{s} \psi^{(1)}(f, -q, a, 0, t) \Big|_{t=0} + \frac{1}{s} L(\psi^{(2)}(f, -q, a, 0, t)) \right). \quad (6.2.1.6)$$

Now repeating the process a total of n times, where n is an integer such that $n + 1 > q > n$ gives

$$L(\psi(f, -q, a, 0, t)) = \frac{1}{s^n} L(\psi^{(n)}(f, -q, a, 0, t)) + \sum_{j=1}^n \frac{1}{s^j} \psi^{(j-1)}(f, -q, a, 0, t) \Big|_{t=0} \quad (6.2.1.7)$$

as the expression for the equivalent initialization function. This equation then yields

$$L({}_0 D_t^{-q} f(t)) = \frac{1}{s^q} L(f(t)) + \frac{1}{s^n} L(\psi^{(n)}(f, -q, a, 0, t)) + \sum_{j=1}^n \frac{1}{s^j} \psi^{(j-1)}(f, -q, a, 0, t) \Big|_{t=0}. \quad (6.2.1.8)$$

The inference of this equation is that the q th differintegral is composed of n order 1 integer integrations and a fractional integration of order $q - n$ (see fig. 6-2-1-1). Further, the order 1 integrations are each initialized by a constant ($\psi^{(j-1)} \Big|_{t=0}$ terms in the summation). This form is useful in showing backward compatibility with contemporary Laplace transform theorems for repeated integer integrals in the integer order calculus, namely for n integrations (see Appendix B),

$$L \left\{ \int_0^t \int_0^{t_1} \int_0^{t_2} \dots \int_0^{t_{n-1}} f(t_n) dt_n dt_{n-1} \dots dt_2 dt_1 \right\} = \frac{1}{s^n} L\{f(t)\} + \sum_{i=1}^n \frac{c_i}{s^i} \quad n = 1, 2, 3, \dots \quad (6.2.1.9)$$

The compatibility is seen by taking $q = n = 1, 2, 3, \dots$ and properly selecting ψ in equation (6.2.1.8). In equation (6.2.1.8) the summation term is the result of repeated application of integration by parts and the term represents a redundancy relative to the preceding term for the generalized calculus.

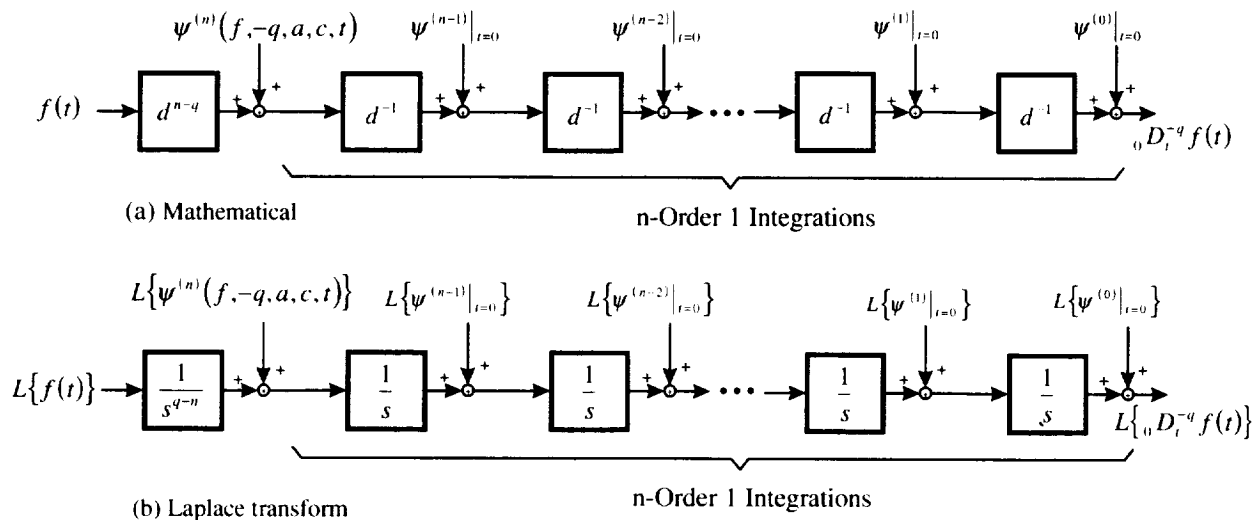

Figure 6-2-1-1.—Block diagrams for integer order decomposition of the fractional integral (eq. (6.2.1.8)).

(a) Mathematical diagram – time domain. (b) Laplace transform – frequency domain.

It is clear that infinitely many more possibilities exist than this form. As a further example the integer order integrations in figure 6-2-1-1 could just as well be replaced by generalized (fractional) integrations each also of order 1. Each of these would allow a non-constant initialization function; thus consider the decomposition shown in figure 6-2-1-2. For this case, ${}_0D_t^{-q} f(t)$ is decomposed into n generalized order 1 integrations and a fractional integration of order $-q + n$. Thus, n is the greatest integer less than q . Since all of the operations are integration, composition holds, and the following may be written relative to this diagram:

$$\begin{aligned}
 {}_0D_t^{-q} f(t) &= \psi_1 + {}_0d_t^{-1} x_{n-1}(t), & q > 0, \\
 &= \psi_1 + {}_0d_t^{-1} (\psi_2 + {}_0d_t^{-1} x_{n-2}(t)), \\
 &= \psi_1 + {}_0d_t^{-1} \psi_2 + {}_0d_t^{-2} (\psi_3 + {}_0d_t^{-1} x_{n-3}(t)), \\
 &= \psi_1 + {}_0d_t^{-1} \psi_2 + {}_0d_t^{-2} \psi_3 + {}_0d_t^{-3} x_{n-3}(t). & (6.2.1.10)
 \end{aligned}$$

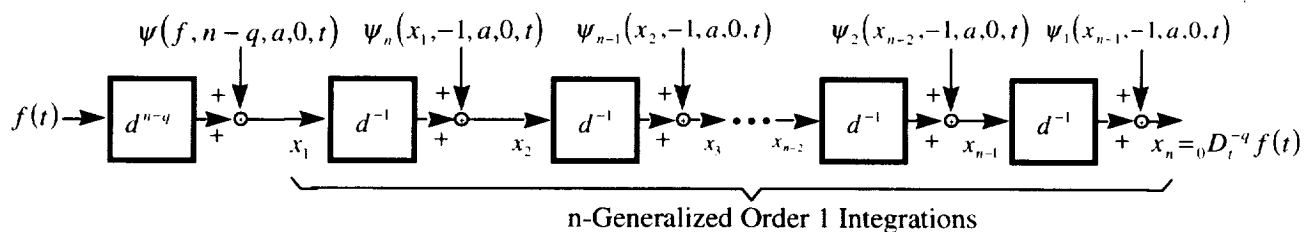

Figure 6-2-1-2.—Mathematical diagram for generalized integer order decomposition of the fractional integral of order q (eq. (6.2.2.12)) for $t > c = 0$.

Repeating this process a total of n times and observing that

$$x_1(t) = \psi(f, -q + n, a, 0, t) + {}_0d_t^{-q+n} f(t), \quad (6.2.1.11)$$

gives the following:

$${}_0D_t^{-q} f(t) = {}_0d_t^{-q} f(t) + {}_0d_t^{-n} \psi(f, -q + n, a, 0, t) + \sum_{j=1}^n {}_0d_t^{-(j-1)} \psi_j(x_j, -1, a, 0, t), \quad (6.2.1.12)$$

as the mathematical representation of the diagram. The Laplace transform is now taken of this equation while noting that the effects of initialization are explicitly included and should not be included again when transforming the uninitialized integral terms.

Thus,

$$L\{{}_0D_t^{-q} f(t)\} = \frac{1}{s^q} L\{f(t)\} + \frac{1}{s^n} L\{\psi(f, -q + n, a, 0, t)\} + \sum_{j=1}^n \frac{1}{s^{(j-1)}} L\{\psi_j(x_j, -1, a, 0, t)\}. \quad (6.2.1.13)$$

Because $L\{const\} = const / s$, it is clear that the difference between this equation and equation (6.2.1.8) is the effect of initializing here by a function of time instead of a constant as in equation (6.2.1.8). This equation (6.2.1.13), of course, is a generalization of equation (6.2.1.8). Further, if q is an integer, namely $q = n$, then $x_1(t) = f(t)$, and $\psi(f, -q + n, a, 0, t)$ may not be required. Then this equation specializes back to the form for the Laplace transform of a multiple integer integral from contemporary transform theory (see Appendix B), namely,

$$L\{{}_a d_t^{-n} f(t)\} = \frac{1}{s^n} L\{f(t)\} + \sum_{j=1}^n \frac{c_j}{s^j}, \quad n = 1, 2, 3, \dots \quad (6.2.1.14)$$

6.2.2 Fractional Order Decomposition of Fractional Integral

A much more general decomposition of ${}_0D_t^{-q} f(t)$ can be obtained that is not limited to integer integral elements. Consider the mathematics associated with the decomposition indicated in figure 6-2-2-1. Since only fractional integrations are considered, composition holds for the case shown in this diagram. Thus, dropping the subscripts on ${}_0D_t^{-q_i}$ for convenience we have

$$D^{-q_n} D^{-q_{n-1}} \dots D^{-q_3} D^{-q_2} D^{-q_1} x_1(t) = x_{n+1}(t) = {}_0D_t^{-q} f(t), \quad t > 0, \quad q_k \geq 0 \quad \forall k, \quad (6.2.2.1)$$

where $q = \sum_{i=1}^n q_i$. Then starting from the inside

$$L\{x_2(t)\} = L\{{}_0d_t^{-q_1} x_1(t)\} + L\{\psi_1(x_1, -q_1, a, 0, t)\}, \quad (6.2.2.2)$$

for which the following shorthand will be used:

$$L\{x_2\} = L\{d^{-q_1} x_1\} + \psi_1(s). \quad (6.2.2.3)$$

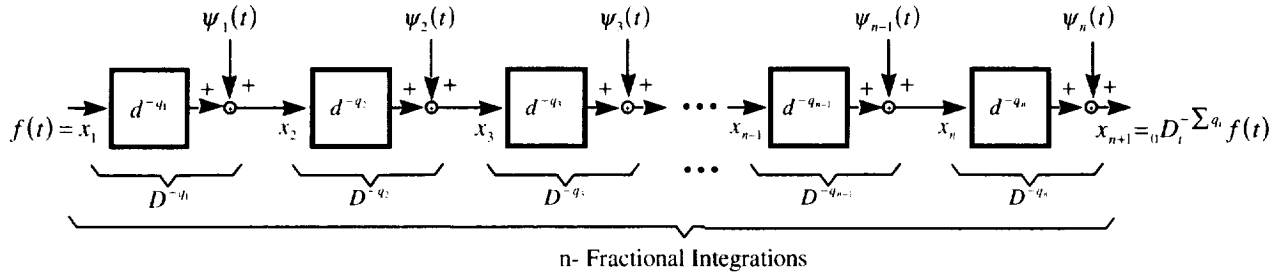

Figure 6-2-2-1.—Mathematical diagram for multiple generalized (fractional) integrations, $t > c = 0$.

Then

$$L\{x_2\} = s^{-q_1} L\{x_1\} + \psi_1(s) \quad (6.2.2.4)$$

and

$$L\{x_3\} = L\{d^{-q_2} x_2\} + \psi_2(s) = s^{-q_2} L\{x_2\} + \psi_2(s) \quad (6.2.2.5)$$

$$= s^{-q_2} \{s^{-q_1} L\{x_1\} + \psi_1(s)\} + \psi_2(s); \quad (6.2.2.6)$$

again

$$L\{x_4\} = L\{d^{-q_3} x_3\} + \psi_3(s) = s^{-q_3} L\{x_3\} + \psi_3(s) \quad (6.2.2.7)$$

$$= s^{-q_3} s^{-q_2} s^{-q_1} L\{x_1\} + s^{-q_3-q_2} \psi_1(s) + s^{-q_3} \psi_2(s) + \psi_3(s) \quad (6.2.2.8)$$

$$= s^{-q_3-q_2-q_1} L(x_1) + s^{-q_3-q_2} \psi_1(s) + s^{-q_3} \psi_2(s) + \psi_3(s). \quad (6.2.2.9)$$

Repeating the process to x_{n+1}

$$L\{x_{n+1}\} = s^{-q_1-q_2-\dots-q_n} L\{x_1\} + s^{-q_2-q_3-\dots-q_n} \psi_1(s) + s^{-q_3-q_4-\dots-q_n} \psi_2(s) + \dots + s^{-q_{n-1}-q_n} \psi_{n-2}(s) + s^{-q_n} \psi_{n-1}(s) + \psi_n(s). \quad (6.2.2.10)$$

Now defining $B_a = \sum_{i=a}^n q_i$ equation (6.2.2.10) can be written as

$$L\{x_{n+1}\} = s^{-B_1} L\{x_1\} + s^{-B_2} \psi_1(s) + \dots + s^{-B_n} \psi_{n-1}(s) + \psi_n(s), \quad (6.2.2.11)$$

or more compactly as

$$L\{ {}_0 D_t^{-q} f(t) \} = L\{ {}_0 D_t^{-B_1} x_1(t) \} = L\{x_{n+1}\} = s^{-B_1} L\{x_1\} + \psi_n(s) + \sum_{j=1}^{n-1} s^{-B_{j+1}} \psi_j(s) \quad (6.2.2.12)$$

where $B_a = \sum_{i=a}^n q_i \quad 1 \leq a \leq n \quad q_k \geq 0 \quad \forall k.$

The attraction of this form is the fact that the q_i can be integer, non-integer or mixed. Further, although this analysis was done for $q > 0$, that is, for fractional integrals the basic form will also be shown to hold for fractional derivatives provided composition is satisfied. The effective initialization then for this case is

$$L\{\psi_{\text{effect}}\} = \psi_n(s) + \sum_{j=1}^{n-1} s^{-B_{j+1}} \psi_j(s). \quad (6.2.2.13)$$

6.3 Laplace Transform of Fractional Derivatives

Again, for simplicity, the starting point is taken as $c = 0$. Here it is desired to evaluate

$$L\{ {}_0 D_t^u f(t) \} = L\{ {}_0 D_t^m {}_0 D_t^{-p} f(t) \}, \quad u > 0, \quad (6.3.1)$$

where m is the least integer $> u$ such that $u = m - p$. Then substituting the definitions and expanding, gives

$$L\{ {}_0 D_t^u f(t) \} = L\{ {}_0 D_t^m {}_0 D_t^{-p} f(t) \} = L\left\{ \frac{d^m}{dt^m} \left(\int_0^t \frac{(t-\tau)^{p-1}}{\Gamma(p)} f(\tau) d\tau \right) \right\} + \\ L\left\{ \frac{d^m}{dt^m} \psi(f, -p, a, 0, t) \right\} + L\{ \psi(h, m, a, 0, t) \}, \quad t > 0, \quad (6.3.2)$$

where $h(t) = {}_a D_t^{-p} f(t)$. The sum of the last two terms on the right-hand side can be thought of as the equivalent ψ for ${}_0 D_t^u f(t)$, thus

$$\boxed{\psi_{eq}(f, u, a, 0, t) = \frac{d^m}{dt^m} \psi(f, -p, a, 0, t) + \psi(h, m, a, 0, t).} \quad (6.3.3)$$

Consider the first term of the right-hand side of equation (6.3.2),

$$L\left\{ \frac{d^m}{dt^m} \left(\int_0^t \frac{(t-\tau)^{p-1}}{\Gamma(p)} f(\tau) d\tau \right) \right\} = \int_0^\infty e^{-st} \frac{d}{dt} \left(\frac{d^{m-1}}{dt^{m-1}} \int_0^t \frac{(t-\tau)^{p-1}}{\Gamma(p)} f(\tau) d\tau \right) dt. \quad (6.3.4)$$

Applying integration by parts where

$$u = e^{-st}, \quad dv = \frac{d}{dt} \left(\frac{d^{m-1}}{dt^{m-1}} \int_0^t \frac{(t-\tau)^{p-1}}{\Gamma(p)} f(\tau) d\tau \right) dt, \quad (6.3.5)$$

then

$$du = -s e^{-st} dt, \quad v = \frac{d^{m-1}}{dt^{m-1}} \int_0^t \frac{(t-\tau)^{p-1}}{\Gamma(p)} f(\tau) d\tau, \quad (6.3.6)$$

yields

$$= e^{-st} \frac{d^{m-1}}{dt^{m-1}} \int_0^t \frac{(t-\tau)^{p-1}}{\Gamma(p)} f(\tau) d\tau \Big|_0^\infty + s \int_0^\infty e^{-st} \frac{d}{dt} \left(\frac{d^{m-2}}{dt^{m-2}} \int_0^t \frac{(t-\tau)^{p-1}}{\Gamma(p)} f(\tau) d\tau \right) dt. \quad (6.3.7)$$

The first term evaluates to zero (further, this term would be a redundant initialization), thus

$$L\left\{\frac{d^m}{dt^m}\left(\int_0^t \frac{(t-\tau)^{p-1}}{\Gamma(p)} f(\tau)d\tau\right)\right\} = sL\left\{\frac{d}{dt}\left(\frac{d^{m-2}}{dt^{m-2}}\int_0^t \frac{(t-\tau)^{p-1}}{\Gamma(p)} f(\tau)d\tau\right)\right\}. \quad (6.3.8)$$

Repeating this process a total of m times yields

$$L\left\{\frac{d^m}{dt^m}\int_0^t \frac{(t-\tau)^{p-1}}{\Gamma(p)} f(\tau)d\tau\right\} = s^m L\left\{{}_0d_t^{-p} f(t)\right\}. \quad (6.3.9)$$

Therefore, one form of equation (6.3.2) is;

$$\begin{aligned} L\left\{{}_0D_t^u f(t)\right\} &= L\left\{{}_0D_t^m {}_0D_t^{-p} f(t)\right\} = \\ &= s^m L\left\{{}_0d_t^{-p} f(t)\right\} + L\left\{\frac{d^m}{dt^m} \psi(f, -p, a, 0, t)\right\} + L\left\{\psi(h, m, a, 0, t)\right\} \end{aligned} \quad (6.3.10)$$

or with equation (6.3.3),

$$L\left\{{}_0D_t^u f(t)\right\} = s^m L\left\{{}_0d_t^{-p} f(t)\right\} + L\left\{\psi(f, u, a, 0, t)\right\}, \quad (6.3.11)$$

where $\psi_{eq}(f, u, a, c, t)$ is written as $\psi(f, u, a, c, t)$ to allow the generalization that follows.

Applying the results for the fractional integral, equation (6.2.5), gives

$$\begin{aligned} L\left\{{}_0D_t^u f(t)\right\} &= s^{m-p} L\left\{f(t)\right\} + L\left\{\psi(f, u, a, 0, t)\right\} \\ &= s^u L\left\{f(t)\right\} + L\left\{\psi(f, u, a, 0, t)\right\}. \end{aligned} \quad (6.3.12)$$

These simple forms are the most general forms for the Laplace transform of ${}_0D_t^u f(t)$. It is noted that this form is the same as that of equation (6.2.5), thus in equation (6.3.12) u may take on any real value.

Now, as in the fractional integral case, there are an infinite number of ways in which ${}_0D_t^u f(t)$ may be decomposed. Thus, there are many possible formulations for $\psi_{eq}(f, u, a, c, t)$. Some of these will now be explored.

6.3.1 Integer Order Decompositions of the Fractional Derivative

An equivalent form may be derived for $L\left\{\psi(f, u, a, 0, t)\right\}$ with u composed of m integer order differentiations and a single order p fractional integration. Consider then, the second term of the RHS of equation (6.3.2) or (6.3.10),

$$L\left\{\frac{d^m}{dt^m} \psi(f, -p, a, 0, t)\right\} = \int_0^\infty e^{-st} \frac{d}{dt} \left(\frac{d^{m-1}}{dt^{m-1}} \psi(f, -p, a, 0, t) \right) dt. \quad (6.3.11)$$

Again, integrating by parts with

$$u = e^{-st}, \quad dv = \frac{d}{dt} \frac{d^{m-1}}{dt^{m-1}} \psi(f, -p, a, 0, t) dt, \quad (6.3.1.2)$$

$$du = -se^{-st} dt, \quad v = \frac{d^{m-1}}{dt^{m-1}} \psi(f, -p, a, 0, t). \quad (6.3.1.3)$$

Therefore,

$$\begin{aligned} L\left\{\frac{d^m}{dt^m} \psi(f, -p, a, 0, t)\right\} &= e^{-st} \frac{d^{m-1}}{dt^{m-1}} \psi(f, -p, a, 0, t) \Big|_0^\infty + s \int_0^\infty e^{-st} \frac{d^{m-1}}{dt^{m-1}} \psi(f, -p, a, 0, t) dt \\ &= -\frac{d^{m-1}}{dt^{m-1}} \psi(f, -p, a, 0, t) \Big|_{t=0} + sL\left\{\frac{d^{m-1}}{dt^{m-1}} \psi(f, -p, a, 0, t)\right\}. \end{aligned} \quad (6.3.1.4)$$

This result can now be applied to determine

$$\begin{aligned} L\left\{\frac{d}{dt} \frac{d^{m-2}}{dt^{m-2}} \psi(f, -p, a, 0, t)\right\} &= \\ &= -\left(\frac{d^{m-2}}{dt^{m-2}} \psi(f, -p, a, 0, t)\right) \Big|_{t=0} + sL\left\{\frac{d^{m-2}}{dt^{m-2}} \psi(f, -p, a, 0, t)\right\}. \end{aligned} \quad (6.3.1.5)$$

Then,

$$\begin{aligned} L\left\{\frac{d^m}{dt^m} \psi(f, -p, a, 0, t)\right\} &= -\frac{d^{m-1}}{dt^{m-1}} \psi(f, -p, a, 0, t) \Big|_{t=0} + \\ &+ s\left(-\left(\frac{d^{m-2}}{dt^{m-2}} \psi(f, -p, a, 0, t)\right) \Big|_{t=0} + sL\left\{\frac{d^{m-2}}{dt^{m-2}} \psi(f, -p, a, 0, t)\right\}\right). \end{aligned} \quad (6.3.1.6)$$

Repeating this process a total of m times and writing

$$\frac{d^k}{dt^k} \psi(f, -p, a, 0, t) = \psi^{(k)}(f, -p, a, 0, t), \quad (6.3.1.7)$$

yields

$$L\left\{\frac{d^m}{dt^m} \psi(f, -p, a, 0, t)\right\} = s^m L\{\psi(f, -p, a, 0, t)\} - \sum_{j=1}^m s^{j-1} \left(\psi^{(m-j)}(f, -p, a, 0, t)\right) \Big|_{t=0}. \quad (6.3.1.8)$$

It is noted here that the summation term, in this equation, is the result of repeated integration by parts from the integer calculus. Clearly an arbitrary ψ may be chosen such that the initialization information contained in the summation can be incorporated into the previous term. That is, the summation term is redundant but will be carried so that an explicit comparison of form back to the integer order calculus may be made.

Substituting equation (6.3.1.8) into equation (6.3.10) gives the following expression for the Laplace transform of the generalized derivative (decomposed into integer differentiations with $\psi^{(m-j)}(f, -p, a, c, t)|_{t=0} = \text{constant initialization}$):

$$L\{ {}_0 D_t^u f(t) \} = L\{ {}_0 D_t^m {}_0 D_t^{-p} f(t) \} = s^m L\{ {}_0 d_t^{-p} f(t) \} + s^m L\{ \psi(f, -p, a, 0, t) \} - \sum_{j=1}^m s^{j-1} \left(\psi^{(m-j)}(f, -p, a, 0, t) \right) \Big|_{t=0} + L\{ \psi(h, m, a, 0, t) \}. \quad (6.3.1.9)$$

Here, ${}_0 d_t^{-p} f(t) = \frac{1}{\Gamma(p)} \int_0^t (t-\tau)^{p-1} f(\tau) d\tau$, is the uninitialized fractional integral originating at

$t = c = 0$ and $h(t) = {}_a d_t^{-p} f(t)$ as defined for equation (6.3.2). Equation (6.3.1.9) is a general expression for either side charging or terminal charging, (but is limited to the case where the ψ terms in the summation evaluate to constants). Equation (6.3.1.9) infers the mathematical block diagram shown in figure 6-3-1-1.

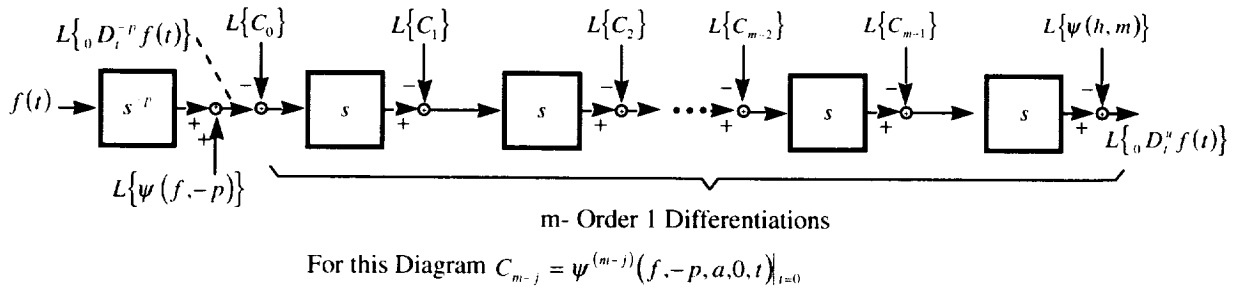

Figure 6-3-1-1.—Mathematical block diagram for equation 6.3.1.10.

The first term of the RHS may be written as $s^u L\{f(t)\}$, and the above equation becomes

$$L\{ {}_0 D_t^u f(t) \} = L\{ {}_0 D_t^m {}_0 D_t^{-p} f(t) \} = s^u L\{f(t)\} - \sum_{j=1}^m s^{j-1} \left(\psi^{(m-j)}(f, -p, a, 0, t) \right) \Big|_{t=0} + L\{ \psi(h, m, a, 0, t) \}. \quad (6.3.1.10)$$

Note, what has been done here is to decompose the integer order derivative part of ${}_0 D_t^u f(t)$, namely, ${}_0 D_t^m$ into m integer differentiations, each of order 1. Specialization of this equation back to the integer order calculus expression for the transform of the derivative, namely,

$$L\{ f^{(m)}(t) \} = s^m L\{f(t)\} - \sum_{j=1}^m s^{j-1} f^{(m-j)}(0^+), \quad (6.3.1.11)$$

can be seen as follows. In equation (6.3.1.10), take $p = 0$ (zero order operator; that this operator can have an initialization in the generalized calculus will be demonstrated in the application section). Set $\psi(h, m, a, 0, t) = 0$ then $\psi(f, 0, a, 0, t)$ can be specialized such that

$$\psi^{(m-j)}(f, 0, a, 0, t) \Big|_{t=0} = f^{(m-j)}(0^+) \quad (6.3.1.12)$$

and the reversion is shown.

In the context of equation (6.3.1.10),

$$L\{\psi(f, u, a, 0, t)\} = - \sum_{j=1}^m s^{j-1} \left(\psi^{(m-j)}(f, -p, a, 0, t) \Big|_{t=0} \right) + L\{\psi(h, m, a, 0, t)\}. \quad (6.3.1.13)$$

Further generalization of equation (6.3.1.10) is possible in several ways. From equation (6.3.2) or (6.3.10) consider, again, the term $L\left\{\frac{d^m}{dt^m} \psi(f, -p, a, 0, t)\right\}$. Now since the initialization can be

completely arbitrary, let

$$\psi(f, -p, a, 0, t) = {}_0d_t^{1-m} \psi_1(t) + {}_0d_t^{2-m} \psi_2(t) + \dots + {}_0d_t^{m-m} \psi_m(t) = \sum_{j=1}^m {}_0d_t^{j-m} \psi_j(t). \quad (6.3.1.14)$$

Then,

$$L\left\{\frac{d^m}{dt^m} \psi(f, -p, a, 0, t)\right\} = L\left\{\sum_{j=1}^m \frac{d^j \psi_j(t)}{dt^j}\right\} = \sum_{j=1}^m s^j L\{\psi_j(t)\}, \quad (6.3.1.15)$$

where the redundant terms have been dropped. Then equation (6.3.1.10) can be generalized to

$$\boxed{L\{{}_0D_t^u f(t)\} = L\{{}_0D_t^m {}_0D_t^{-p} f(t)\} = s^u L\{f(t)\} + \sum_{j=1}^m s^j L\{\psi_j(t)\} + L\{\psi(h, m, a, 0, t)\}. \quad (6.3.1.16)}$$

The difference in the two equations, of course, is that here the order 1 derivatives are each initialized by time varying functions. The inference of this is that the order 1 differentiations are now generalized order 1 differentiations. The derivative initialization $L\{\psi(h, m, a, 0, t)\}$ can also be similarly distributed over the order 1 derivative terms to produce a similar effect.

6.3.2 Fractional Order Decompositions of the Fractional Derivative

The Laplace transform of the generalized (fractional) derivative may also be based on decomposition into fractional derivatives and integrals. The general fractional order decomposition of the fractional integral as performed in a previous subsection may be extended to the case with fractional derivatives. To do this, replace the fractional integrations indicated in figure 6-2-2-1 by fractional differentiations; let $-q_k = r_k$ with $r_k \geq 0 \quad \forall k$ (refer to fig. 6-3-2-1).

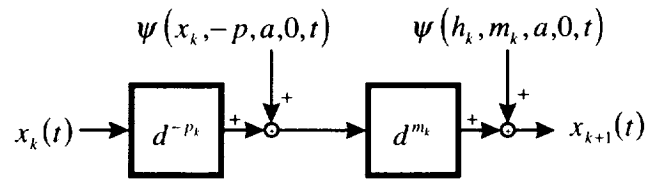

(a) Differentiation element

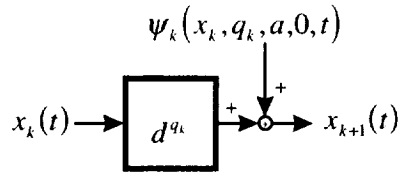

(b) Equivalent differentiation element

Figure 6-3-2-1.—Fractional differentiation element. (a) Differentiation element.
(b) Equivalent differentiation element.

Then the decomposition is valid provided: (1) that composition is satisfied at each step of the reduction and (2) that for each k such that $r_k > 0$, the initialization ψ_k is considered as the equivalent ψ for differentiation, namely from equation (6.3.3),

$$\psi_k(x_k, r_k, a, 0, t) = \frac{d^{m_k}}{dt^{m_k}} \psi(x_k, -p_{k-1}, a, 0, t) + \psi(h_k, m_k, a, 0, t), \quad (6.3.2.1)$$

where m_k is the least integer such that $r_k = m_k - p_k$ and $h_k = {}_a d_t^{-p_k} x_k(t)$. The result then by identical mathematics as in the integral case is

$$L\{ {}_0 D_t^q f(t) \} = L\{ {}_0 D_t^{B_a} x_1(t) \} = L\{ x_{n+1}(t) \} = s^{B_a} L\{ x_1(t) \} + \psi_n(s) + \sum_{j=1}^{n-1} s^{B_{j+1}} \psi_j(s), \quad (6.3.2.2)$$

where $B_a = \sum_{i=a}^n r_i, \quad r_k \geq 0 \quad \forall k, \quad 1 \leq a \leq n.$

Clearly the extension of this result to all r_k additionally requires the full applicability of the mixed-mode form of the composition law (eq. (5.5.4.8)) and the use of the equivalent ψ as given in equation (6.3.2.1) whenever $r_k > 0$. This general result, equation (6.3.2.2), for all r_k is probably the most powerful and useful of the forms derived in this subsection.

6.4 Effect of Terminal Charging on Laplace Transforms

In the results generated in this section all ψ terms were treated as completely arbitrary, that is, a side charging assumption is implicitly made and the forms above apply to either terminal or side charging. The effects of terminal charging may be readily determined by appropriate

substitutions for the ψ terms. That is, for the integer derivative terms substitute $\psi(h, m, a, 0, t) = 0 \quad m = 1, 2, \dots$, and for the fractional integrations (either as part of the derivative or alone) take

$$\psi(f, -p, a, 0, t) = \frac{1}{\Gamma(p)} \int_a^0 (t - \tau)^{p-1} f(\tau) d\tau. \quad (6.4.1)$$

Of course it is not necessary to terminal charge both terms of the derivative, but the choice is made based on the desired decomposition.

Some modest simplifications may be achieved. For example, relative to the Laplace transform of the fractional integral, the $\psi^{(k)}$ terms in equation (6.2.1.8), if terminal charging is assumed, are

$$\psi^{(k)}(f, -q, a, 0, t) \Big|_{t=0} = \left\{ \frac{d^{k-1}}{dt^{k-1}} \left(\frac{d}{dt} \int_a^0 \frac{(t - \tau)^{q-1}}{\Gamma(q)} f(\tau) d\tau \right) \right\} \Big|_{t=0}, \quad t > 0. \quad (6.4.2)$$

Applying Liebnitz's rule gives

$$\psi^{(k)}(f, -q, a, 0, t) \Big|_{t=0} = \left\{ \frac{d^{k-2}}{dt^{k-2}} \left(\frac{d}{dt} \int_a^0 \frac{(q-1)(t - \tau)^{(q-1)-1}}{\Gamma(q)} f(\tau) d\tau \right) \right\} \Big|_{t=0}, \quad t > 0. \quad (6.4.3)$$

Now because $(q-1)/\Gamma(q) = 1/\Gamma(q-1)$, the integral is recognized as the initialization of the $(q-1)$ th order differintegral and continuing the process yields

$$\psi^{(k)}(f, -q, a, 0, t) \Big|_{t=0} = \psi(f, -q+k, a, 0, t) \Big|_{t=0}, \quad t > 0. \quad (6.4.4)$$

In similar manner, the more general term in equation (6.2.1.8) yields

$$\psi^{(n)}(f, -q, a, 0, t) = \psi(f, -q+n, a, 0, t) = \frac{1}{\Gamma(q-n)} \int_a^0 (t - \tau)^{q-n-1} f(\tau) d\tau, \quad t > 0, \quad (6.4.5)$$

where $n+1 > q > n > 0$ and n is an integer.

6.5 Effect of Starting Point

6.5.1 Fractional Integral

The effect of starting with non-zero a (and c) is considered for the fractional integral. Specifically, the case of $c > a \geq 0$, and $q > 0$ is considered. Then for the uninitialized fractional integral

$$L\{ {}_a D_t^{-q} f(t) \} = L\{ {}_a d_t^{-q} f(t) \} = L\left\{ \frac{1}{\Gamma(q)} \int_a^t (t - \tau)^{q-1} f(\tau) d\tau \right\}, \quad q > 0. \quad (6.5.1.1)$$

By definition $f(t) = 0$, for $t \leq a$, therefore we can write

$$f(t) = u(t-a)f(t), \quad (6.5.1.2)$$

where $u(t)$ is the unit step function, and thus the result is

$$L\{ {}_a D_t^{-q} f(t) \} = L\{ {}_a d_t^{-q} f(t) \} = L\{ {}_0 d_t^{-q} (u(t-a)f(t)) \}, \quad q > 0, \quad a \geq 0. \quad (6.5.1.3)$$

6.5.2 Fractional Derivative

Under the same conditions as above, the uninitialized fractional derivative is considered, then

$$L\{ {}_a d_t^q f(t) \} = L\{ {}_a d_t^m {}_a d_t^{-p} f(t) \} = L\left\{ \frac{d^m}{dt^m} \frac{1}{\Gamma(p)} \int_a^t (t-\tau)^{p-1} f(\tau) d\tau \right\}, \quad q > 0, \quad (6.5.2.1)$$

and as before m is the least integer $> q$ such that $q = m - p$. Again by definition,

$f(t) = 0$ for $t \leq a$, therefore we can write

$$f(t) = u(t-a)f(t). \quad (6.5.2.2)$$

Thus

$$L\{ {}_a d_t^q f(t) \} = L\left\{ \frac{d^m}{dt^m} \frac{1}{\Gamma(p)} \int_0^t (t-\tau)^{p-1} u(\tau-a)f(\tau) d\tau \right\} \quad (6.5.2.3)$$

$$= L\left\{ \frac{d^m}{dt^m} {}_0 d_t^{-p} (u(t-a)f(t)) \right\} = L\{ {}_0 d_t^q (u(t-a)f(t)) \}, \quad q > 0. \quad (6.5.2.4)$$

Thus, combining results of equations (6.5.1.3) and (6.5.2.4) gives

$$L\{ {}_a d_t^q f(t) \} = L\{ {}_0 d_t^q (u(t-a)f(t)) \}, \quad \forall q. \quad (6.5.2.5)$$

6.6 Laplace Transform of Initialization Function

6.6.1 Fractional Integral

It will sometimes be useful to deal with the initialization function in the Laplace domain. From Laplace transform theory (Wylie (1975) p. 281) the so called first shifting theorem is given by

$$L\{ g(t-a)u(t-a) \} = e^{-as} L\{ g(t) \}, \quad a \geq 0. \quad (6.6.1.1)$$

Letting $f(t) = g(t - a)$, this can be rewritten as

$$L\{f(t)u(t - a)\} = e^{-as}L\{f(t + a)\}, \quad a \geq 0. \quad (6.6.1.2)$$

Now for the fractional integral (under terminal charging), the desired Laplace transform then is

$$L\{\psi(f, -q, a, c, t)\} = L\{{}_a d_t^{-q} f(t)\} - L\{{}_c d_t^{-q} f(t)\}. \quad (6.6.1.3)$$

Using the above result, equation (6.5.1.3)

$$= L\{{}_0 d_t^{-q} f(t)u(t - a)\} - L\{{}_0 d_t^{-q} f(t)u(t - c)\} \quad (6.6.1.4)$$

$$= s^{-q}L\{f(t)u(t - a)\} - s^{-q}L\{f(t)u(t - c)\} \quad (6.6.1.5)$$

and applying the modified shifting theorem gives the result, for $q > 0$,

$$L\{\psi(f, -q, a, c, t)\} = s^{-q}[e^{-as}L\{f(t + a)\} - e^{-cs}L\{f(t + c)\}], \quad c \geq a > 0. \quad (6.6.1.6)$$

6.6.2 Fractional Derivative

The equivalent initialization function for the fractional derivative ${}_c D_t^u f(t) = {}_c D_t^m {}_c D_t^{-p} f(t)$ is given by (eq. (6.3.3))

$$\psi_{c,q}(f, u, a, c, t) = \frac{d^m}{dt^m} \psi(f, -p, a, c, t) + \psi(h, m, a, c, t), \quad u > 0, \quad (6.6.2.1)$$

where m is the least integer $> u$ such that $u = m - p$. For terminal charging it has been show that $\psi(h, m, a, c, t) = 0$, therefore

$$L\{\psi(f, u, a, c, t)\} = s^m L\{\psi(f, -p, a, c, t)\}, \quad (6.6.2.2)$$

and applying the above result (equation (6.6.1.6)) for the fractional integral yields

$$L\{\psi(f, u, a, c, t)\} = s^u [e^{-as}L\{f(t + a)\} - e^{-cs}L\{f(t + c)\}], \quad c \geq a > 0. \quad (6.6.2.3)$$

6.7 Summary—Comments on Laplace Transforms of Differintegrals

(1) The general case forms of equations (6.2.5) and (6.3.12) for the fractional integral and derivative, respectively, will be most useful in many applications. Subject to satisfaction of continuity and composition/index law as required in the derivations, these solutions may be combined into the single form

$$\boxed{L\{{}_0 D_t^q f(t)\} = s^q L\{f(t)\} + L\{\psi(f, q, a, 0, t)\}}, \quad \forall q. \quad (6.7.1)$$

Where for fractional integration ($q < 0$), $\psi(f, q, a, 0, t)$ is arbitrary and for fractional differentiation ($q > 0$) where $q = m - p$ and m is the least integer $> q$, then

$$\psi(f, q, a, 0, t) = \frac{d^m}{dt^m} \psi(f, -p, a, 0, t) + \psi(h, m, a, 0, t)$$

where $h(t) = {}_a d_t^{-p} f(t)$. The use of equations (6.7.1) and (6.7.2), along with block diagrams, to clearly delineate the component parts of the various elements (the decomposition) can be an exceedingly useful approach.

(2) The solution of integrodifferential equations containing the combination of fractional order and integer order terms (non-generalized) can effectively apply the forms of equations (6.2.1.8) and (6.3.1.10) for initialization by constants for the integer order terms. When the forms contain generalized integer order terms the equations (6.2.1.13) and (6.3.1.16) should be applied. Of course these later two equations are generalizations of the former two and may with care be used in both cases.

(3) The forms for the Laplace transforms with fractional decompositions are still more general than either pair of equations discussed in (2) above. These are equations (6.2.2.12) and (6.3.2.2) and are nearly identical in form. In fact these equations taken together may be generalized into a single result, which is equation (6.3.2.2) with r_k free to take on both positive and negative values, that is,

$$L\{ {}_0 D_t^{B_a} x_1(t) \} = L\{ x_{n+1}(t) \} = s^{B_a} L\{ x_1(t) \} + \psi_n(s) + \sum_{j=1}^{n-1} s^{B_{j+1}} \psi_j(s), \quad (6.7.2)$$

where $B_a = \sum_{i=a}^n r_i, \quad \forall r_k, \quad 1 \leq a \leq n.$

For this equation, when $r_k > 0$ it is understood to be interpreted as $r_k = m_k - p_k$ as derived in (6.3.2.2).

(4) Many of the forms derived in this section on the Laplace transform have been derived to demonstrate how the initialization function generalizes the Laplace transforms seen in the integer order calculus. An example of this is the reduction of equations (6.3.1.10) and (6.3.1.16) to the familiar form of equation (6.3.1.11) for the n th derivative, when $\psi(t)$ is specialized to be a constant. Similar is the reduction of equations (6.2.1.8) and (6.2.1.13) to equation (6.2.1.9) for the Laplace transform of multiple (integer order) integrals.

(5) The reader is **cautioned** in the use of these forms to assure that the constraints of continuity and the adherence of the index /composition laws are met as required in the derivations.

(6) The selection of appropriate initialization functions when structuring fractional differential equations will be analogous to, but somewhat more demanding than, the selection of constants when structuring ordinary differential equations. Experience working with particular equation types and/or types of physical systems will be required of the analyst in the selection of initialization functions.

7. Applications

The domain of applications and potential applications for the fractional calculus appears to be very broad indeed. However, the depth of research and application of the fractional calculus appears to be quite limited in most fields, with the exception of rheology (and viscoelasticity in particular). Broadly the applications and potential applications are found in diffusion processes, electrical science, electrochemistry, rheology, material creep, viscoelasticity, dynamics, and controls. Preliminary investigations have also been made into the applicability of the fractional calculus to acoustics, boundary layer theory, and turbulence. Further research has been directed to the relationships between fractional calculus and fractals. A special (non-exhaustive) set of application references has been provided following the general references that direct the reader to these areas. It should be noted that not all of the references in this section contain explicit reference to the fractional calculus, but are included because either theoretical or experimental responses are observed that infer fractional calculus based behavior.

This section studies a variety of applications and analogues of the operators and combined operations of the generalized (fractional) calculus. The intentions are: (1) to demonstrate the broad array of uses of the generalized (fractional) calculus, (2) to clearly delineate the effects of the initialization function, (3) to contrast generalized versus integer order (calculus) integration and differentiation, (4) to demonstrate the generalized zero property, (5) to demonstrate the uses of some of the Laplace transform tools (forms), (6) to demonstrate some of the unusual aspects of the mathematics, and (7) to demonstrate that the generalization of the zero property, (i.e., eq. (5.3.12) may allow the analysis of otherwise insoluble (with the fractional calculus) problems). The problems, hopefully, will appeal to both the mathematician and the engineer/scientist.

7.1 Preliminaries

Two semi-infinite electrical lines and the op amp (operational amplifier) will be used as key building elements for some of the examples that follow. The time domain behavior of these elements is summarized here.

7.1.1 Half Order Element

The half order element (semi-infinite lossy line (Hartley and Lorenzo (1998))) is based on the one-dimensional diffusion equation

$$\frac{\partial v}{\partial t} = \alpha \frac{\partial^2 v}{\partial x^2}, \quad (7.1.1.1)$$

which is depicted by a ladder of discrete resistors and capacitors as shown in figure 7-1-1. In actuality the resistance and capacitance in this and the inductance in figure 7-1-2 are continuously distributed over distance. The terminal characteristics (fig. 7-1-1) of this equation (the driving point (impedance) solution) is mathematically described by

$$v(t) = r\sqrt{\alpha} \frac{d^{-1/2} i(t)}{dt^{-1/2}} + \varphi_1(t) \quad (7.1.1.2)$$

or

$$v(t) = r\sqrt{\alpha} {}_c D_t^{-1/2} i(t), \quad \text{where } \psi(i, -1/2, a, c, t) = \frac{1}{r\sqrt{\alpha}} \varphi_1(t),$$

or

$$i(t) = \frac{1}{r\sqrt{\alpha}} \frac{d^{1/2} v(t)}{dt^{1/2}} + \varphi_2(t), \quad (7.1.1.3)$$

or

$$i(t) = \frac{1}{r\sqrt{\alpha}} {}_c D_t^{1/2} v(t), \quad \text{where } \psi(v, 1/2, a, c, t) = r\sqrt{\alpha} \varphi_2(t).$$

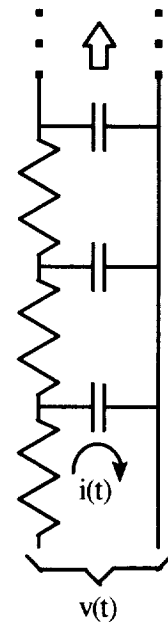

Figure 7-1-1.—Half order element.

Here $v(t)$ and $i(t)$ are the voltage and current, respectively, at the terminal of the element, r is the resistance per length of the line, and α is the product of r and c (the capacitance per unit length of the line). The ψ 's are the initializations and in both cases are determined by the initial state of charge and voltage or current that exists on the infinite array of elements.

7.1.2 Zero Order Element

The second element that will be used is the zero order element (semi-infinite lossless line), figure 7-1-2. It has terminal characteristics which are wave equation based and is mathematically described (Hartley and Lorenzo (1998) eq. 42) by either of the following equations:

$$i(t) = \sqrt{\frac{c}{\ell}} v(t) + \varphi_3(t), \quad (7.1.2.1)$$

or

$$i(t) = \sqrt{\frac{c}{\ell}} {}_c D_t^0 v(t), \quad \text{where } \psi(v, 0, a, c, t) = \sqrt{\frac{\ell}{c}} \varphi_3(t),$$

or

$$v(t) = \sqrt{\frac{\ell}{c}} i(t) + \varphi_4(t), \quad (7.1.2.2)$$

or

$$v(t) = \sqrt{\frac{\ell}{c}} {}_c D_t^0 i(t), \quad \text{where } \psi(i, 0, a, c, t) = \sqrt{\frac{c}{\ell}} \varphi_4(t).$$

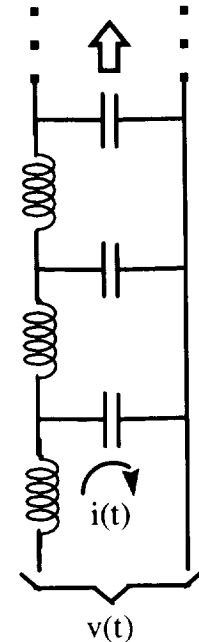

Figure 7-1-2.—Zero order element.

Here ℓ and c are the inductance and capacitance per unit length of the semi-infinite line. Again, it is the initial conditions on the distributed inductors (ℓ 's) and capacitors (c 's) along the infinite lines that give rise to the initialization functions (of time). Details of the physics relative to the expressions for the φ functions are given in Hartley and Lorenzo (1998).

7.1.3 Operational Amplifier

The operational amplifier is a common element in electrical circuits. To analyze it we introduce the concepts of impedance and transfer function. For convenience, the circuit of figure 7-1-3 will be analyzed in a general way here, for use in the later examples. The terms Z_i and Z_f , the input and output impedances (voltage to current ratios), respectively, will represent general linear circuit elements together with their initialization functions (therefore are not strictly speaking impedances).

Then, as Laplace transformed variables

$$v_i(s) - v_g(s) = i_i(s)Z_i(s) \quad \text{input element,} \quad (7.1.3.1)$$

$$v_g(s) - v_o(s) = i_f(s)Z_f(s) \quad \text{feedback element,} \quad (7.1.3.2)$$

$$i_i(s) - i_f(s) - i_g(s) = 0 \quad \text{grid node.} \quad (7.1.3.3)$$

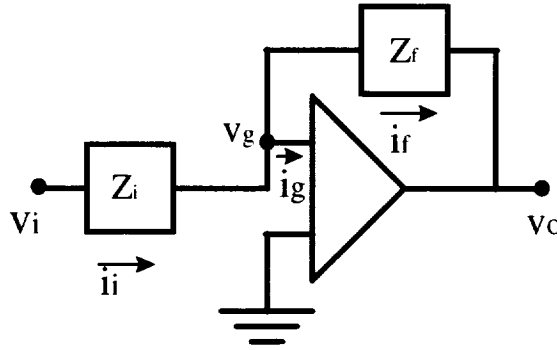

Figure 7-1-3.—Operational amplifier circuit.

These amplifiers are designed so that ideally $i_g \cong 0$ thus $v_g \cong 0$. Then, after algebraic reduction, the resulting (voltage-to-voltage) transfer function

$$\frac{v_o(s)}{v_i(s)} = -\frac{Z_f(s)}{Z_i(s)} \quad (7.1.3.4)$$

summarizes the behavior of the device. In the examples that follow we will sometimes use this result rather than rewrite the detailed equation set for the elements and node each time. In the next five subsections these basic elements will be used to assemble voltage based (computing) circuits of both fractional and integer order devices. Several approaches will be used in these subsections.

7.2 Integrators

7.2.1 Classical (Integer Order Calculus) Integrator

An idealized implementation of the classical integrator used in analog computation is shown in figure 7-2-1. This integrator characterizes integration in the integer order calculus context. The defining equations are

$$v_i(t) - v_g(t) = i_i R, \quad (7.2.1.1)$$

$$\begin{aligned}
 v_r(t) - v_o(t) &= \frac{1}{C} {}_c D_t^{-1} i_f(t) = \frac{1}{C} \int_c^t i_f(\tau) d\tau + \frac{1}{C} \int_a^c i_f(\tau) d\tau \\
 &= \frac{1}{C} \int_c^t i_f(\tau) d\tau + \frac{q(c)}{C} = \frac{1}{C} \int_c^t i_f(\tau) d\tau + (v_r(c) - v_o(c)), \quad (7.2.12)
 \end{aligned}$$

$$i_f = i_i \quad \text{and} \quad v_r(t) = 0, \quad (7.2.13)$$

where $q(c)$ is the initial charge on the capacitor. This equation set yields

$$\begin{aligned}
 v_o(t) &= -\frac{1}{RC} \int_c^t v_i(\tau) d\tau + v_o(c) = -\frac{1}{RC} {}_c D_t^{-1} v_i(t), \\
 &\text{with } \psi(v_i, -1, a, c, t) = -RC v_o(c). \quad (7.2.14)
 \end{aligned}$$

Then, with $RC = 1$, this integrator would be represented in the generalized calculus as $v_o(t) = -{}_c D_t^{-1} v_i(t)$. The full effect of all past history is then contained in a single number, the initialization function, and is the constant $-v_o(c)$, compatible with the integer order calculus. This is contrasted with the following case.

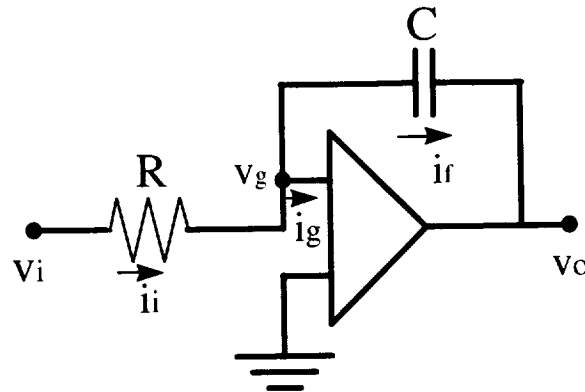

Figure 7-2-1.—Classical (order 1) integrator.

7.2.2 Generalized (Calculus) Integrator

Consider the op amp circuit shown in figure 7-2-2. The input element to the op amp is the lossless transmission line (zero order element). Its behavior is described by the wave equation

$$\frac{\partial^2 v(x,t)}{\partial t^2} = \frac{1}{\ell c} \frac{\partial^2 v(x,t)}{\partial x^2} \quad (7.2.2.1)$$

with appropriate boundary conditions. Here the solution at the terminal, equation (7.1.2.1), will be used directly. The defining equations for this integrator are then

$$i_i(t) = \sqrt{\frac{c}{\ell}} (v_i(t) - v_r(t)) + \phi_3(t), \quad (7.2.2.2)$$

for the zero order input element, and

$$v_g(t) - v_o(t) = \frac{1}{C} {}_c D_t^{-1} i_f(t) = \frac{1}{C} \int_c^t i_f dt - v_o(c), \quad (7.2.2.3)$$

$$i_i = i_f, \quad v_g = 0. \quad (7.2.2.4)$$

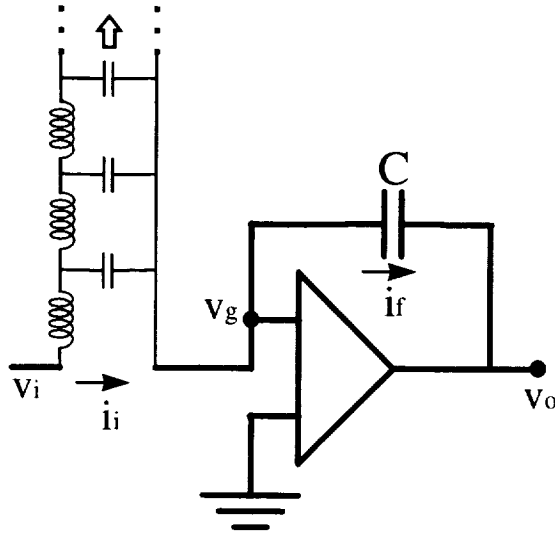

Figure 7-2-2.—Generalized (order 1) integrator.

Therefore, solving for $v_o(t)$ gives

$$v_o(t) = -\frac{1}{C} \int_c^t \left(\sqrt{\frac{c}{\ell}} v_i(\tau) + \varphi_3(\tau) \right) d\tau + v_o(c), \quad (7.2.2.5)$$

$$v_o(t) = -\left(\frac{1}{C} \sqrt{\frac{c}{\ell}} \right) \int_c^t v_i(\tau) d\tau - \frac{1}{C} \int_c^t \varphi_3(\tau) d\tau + v_o(c), \quad (7.2.2.6)$$

$$v_o(t) = -\left(\frac{1}{C} \sqrt{\frac{c}{\ell}} \right) {}_c D_t^{-1} v_i(t), \quad (7.2.2.7)$$

where

$$\psi(v_i, -1, a, c, t) = \sqrt{\frac{\ell}{c}} \int_c^t \varphi_3(\tau) d\tau + C \sqrt{\frac{\ell}{c}} v_o(c), \quad t > c. \quad (7.2.2.8)$$

Taking unity values for the circuit parameters C and c/ℓ , the generalized calculus expression for the circuit is then

$$v_o(t) = -{}_c D_t^{-1} v_i(t). \quad (7.2.2.9)$$

This is, of course, the same expression as seen in equation (7.2.1.4) for the classical calculus based integrator. The important difference is in the values of the respective initialization functions. It is further important to note that the detailed evaluation done above to obtain ψ would seldom be required in application. For this distributed integrator, the effect of the past history is contained not only in the constant $v_0(c)$, which is the charge on the capacitor, but is also carried in the remainder of the $\psi(t)$ function, which accounts for the distributed charge along the semi-infinite line. It is also observed here that the zero order input element, since it is a wave equation, will simply propagate any perturbation in $v_i(t)$ along the semi-infinite line never to be seen again, the only effect being a proportional variation in the current $i_i(t)$. This behavior is true for terminal charging, however for the more general case of a side charged line a (an additional) time function may be returned to the circuit output, which is dependent on the initial voltage distribution on the line.

7.3 Differentiators

7.3.1 Classical (Integer Order Calculus) Differentiator

An idealized circuit for differentiation is shown in figure 7-3-1. The defining equations are

$$\begin{aligned} v_i(t) - v_g(t) &= \frac{1}{C} {}_c D_t^{-1} i_i(t) = \frac{1}{C} \int_c^t i_i(\tau) d\tau + \frac{1}{C} \int_a^c i_i(\tau) d\tau, \\ &= \frac{1}{C} \int_c^t i_i(\tau) d\tau + \frac{q(c)}{C} = \frac{1}{C} \int_c^t i_i(\tau) d\tau + v_{i-g}(c), \end{aligned} \quad (7.3.1.1)$$

$$v_g(t) - v_o(t) = i_f(t) R, \quad (7.3.1.2)$$

$$i_i(t) = i_f(t), \quad v_g(t) = 0. \quad (7.3.1.3)$$

This yields

$$v_o(t) = -R i_i(t) = -RC \left\{ \frac{d}{dt} (v_i(t) - v_{i-g}(c)) \right\}, \quad (7.3.1.4)$$

$$\boxed{v_o(t) = -RC {}_c D_t^1 v_i(t), \quad t > c.} \quad (7.3.1.5)$$

The initialization function $\psi(v_i, 1, a, 0, t)$ is the term $\frac{d}{dt} v_{i-g}(c)$, and is normally taken as zero;

however, it can give rise to a pulse response at time $t = c$. This classical differentiator ($RC = 1$) is contrasted with the case below.

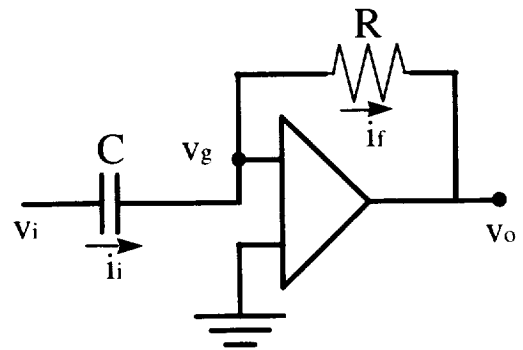

Figure 7-3-1.—Classical (order 1) differentiator.

7.3.2 Generalized (Calculus) Differentiator

The following equation set describes the generalized differentiator as shown in figure 7-3-2.

$$v_i(t) - v_r(t) = \frac{1}{C} {}_c D_t^{-1} i_i(t) = \frac{1}{C} \int_c^t i_i(\tau) d\tau + v_{i-r}(c). \quad (7.3.2.1)$$

For the zero element

$$v_g(t) - v_o(t) = \sqrt{\frac{\ell}{c}} {}_c D_t^0 i_f(t) = \sqrt{\frac{\ell}{c}} i_f(t) + \sqrt{\frac{\ell}{c}} \psi(i_f, 0, a, c, t), \quad (7.3.2.2)$$

$$i_i(t) = i_f(t), \quad v_r = 0 \quad (7.3.2.3)$$

These equations then yield

$$v_o(t) = -\sqrt{\frac{\ell}{c}} \left\{ C \frac{d}{dt} (v_i(t) - v_{i-r}(c)) + \psi(i_f, 0, a, c, t) \right\} \quad (7.3.2.4)$$

or

$$v_o(t) = -C \sqrt{\frac{\ell}{c}} \left\{ \frac{d}{dt} v_i(t) + \frac{1}{C} \psi(v_i, 1, a, c, t) \right\} \quad (7.3.2.5)$$

$$\boxed{v_o(t) = -C \sqrt{\frac{\ell}{c}} {}_c D_t^1 v_i(t)} \quad (7.3.2.6)$$

where the initialization function associated with the generalized derivative is given by

$$\boxed{\psi(v_i, 1, a, c, t) = -\frac{1}{C} \psi(i_f, 0, a, c, t)}. \quad (7.3.2.7)$$

It is noted again that for the terminally charged integer order differentiation, $\psi_{diff} = 0$. This is proven in the derivation associated with definition of the generalized derivative. As in the generalized integrator case, this may also be observed from the physical behavior of the zero order element; this is wave equation based and it is well known that disturbances at the terminal end will be propagated away from the terminal and are not reflected back because of the infinite length of the line. Again, for the more general case of a side charged line a (an additional) time function will be returned to the circuit output.

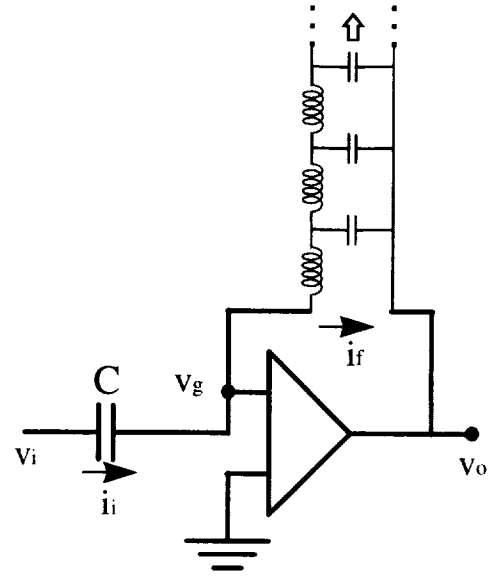

Figure 7-3-2.—Classical (order 1) differentiator.

7.4 Zero Order Operators (ZOOs)

7.4.1 Classical (Calculus) ZOO

An electrical circuit for a voltage-to-voltage ZOO is presented in figure 7-4-1. The defining equations are

$$v_i(t) - v_g(t) = R_i i_i(t), \quad (7.4.1.1)$$

$$v_g(t) - v_o(t) = R_f i_f(t), \quad (7.4.1.2)$$

$$i_i(t) = i_f(t), \quad v_g(t) = 0. \quad (7.4.1.3)$$

Then from the above equations or from equation 7.1.3.4, with $Z_f = R_f$ and $Z_i = R_i$,

$$v_o(t) = -\frac{R_f}{R_i} v_i(t) = -\frac{R_f}{R_i} {}_c D_t^0 v_i(t), \quad (7.4.1.4)$$

where $\psi(v_i, 0, a, c, t) = 0$. Clearly this device has no memory. Contrast this with the following cases.

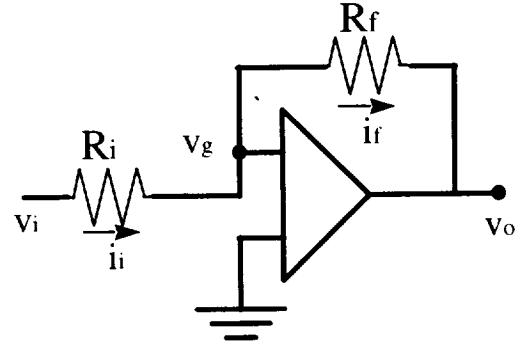

Figure 7-4-1.—Classical (calculus) zero order operator.

7.4.2 Generalized (Calculus) ZOOs

There are several (many) possible electrical realizations for the zero order operator. Three of these are shown in figure 7-4-2, only the last circuit of figure 7-4-2 will be analyzed. Not surprisingly, the voltage-to-voltage zero order elements are based on the voltage-to-current zero order element described earlier (eq. (7.1.2.1) and (7.1.2.2)). The defining equations are

$$i_i(t) = \sqrt{\frac{c_i}{\ell_i}} {}_c D_t^0 (v_i(t) - v_g(t)), \quad (7.4.2.1)$$

where

$$\psi(v_i - v_g, 0, a, c, t) = \sqrt{\frac{\ell_i}{c_i}} \phi_3(t), \quad (7.4.2.2)$$

$$v_g(t) - v_o(t) = \sqrt{\frac{\ell_f}{c_f}} {}_c D_t^0 i_f(t), \quad (7.4.2.3)$$

where

$$\psi(i_f, 0, a, c, t) = \sqrt{\frac{c_f}{\ell_f}} \phi_4(t), \quad (7.4.2.4)$$

$$i_i(t) = i_f(t), \quad v_g(t) = 0. \quad (7.4.2.5)$$

Then

$$v_o(t) = -\sqrt{\frac{\ell_f}{c_f}} {}_c D_t^0 \left(\sqrt{\frac{c_i}{\ell_i}} {}_c D_t^0 v_i(t) \right) = -\sqrt{\frac{\ell_f c_i}{\ell_i c_f}} {}_c D_t^0 v_i(t) \quad (7.4.2.6)$$

$$= -\sqrt{\frac{\ell_f}{c_f}} {}_c d_t^0 \left(\sqrt{\frac{c_i}{\ell_i}} \left\{ {}_c d_t^0 v_i(t) + \psi(v_i - v_g, 0, a, c, t) + \psi(i_f, 0, a, c, t) \right\} \right), \quad (7.4.2.7)$$

$$= -\sqrt{\frac{\ell_f c_i}{c_f \ell_i}} {}_c d_t^0 v_i(t) - \sqrt{\frac{\ell_f}{c_f}} \varphi_3(t) - \varphi_4(t), \quad (7.4.2.8)$$

and

$$v_o(t) = -\sqrt{\frac{\ell_f c_i}{c_f \ell_i}} {}_c D_t^0 v_i(t). \quad (7.4.2.9)$$

The associated initialization is given by

$$\begin{aligned} \psi(v_i, 0, a, c, t) &= \psi(v_i - v_g, 0, a, c, t) + \sqrt{\frac{\ell_i}{c_i}} \psi(i_f, 0, a, c, t) \\ &= \sqrt{\frac{\ell_i}{c_i}} \varphi_3(t) + \sqrt{\frac{\ell_i c_f}{\ell_f c_i}} \varphi_4(t), \end{aligned} \quad (7.4.2.10)$$

and is the initialization function for the full circuit. Here it is seen that the zero order operator in the general case returns the input function $v_i(t)$ but also provides the *extra* time function $\psi(v_i, 0, a, c, t)$.

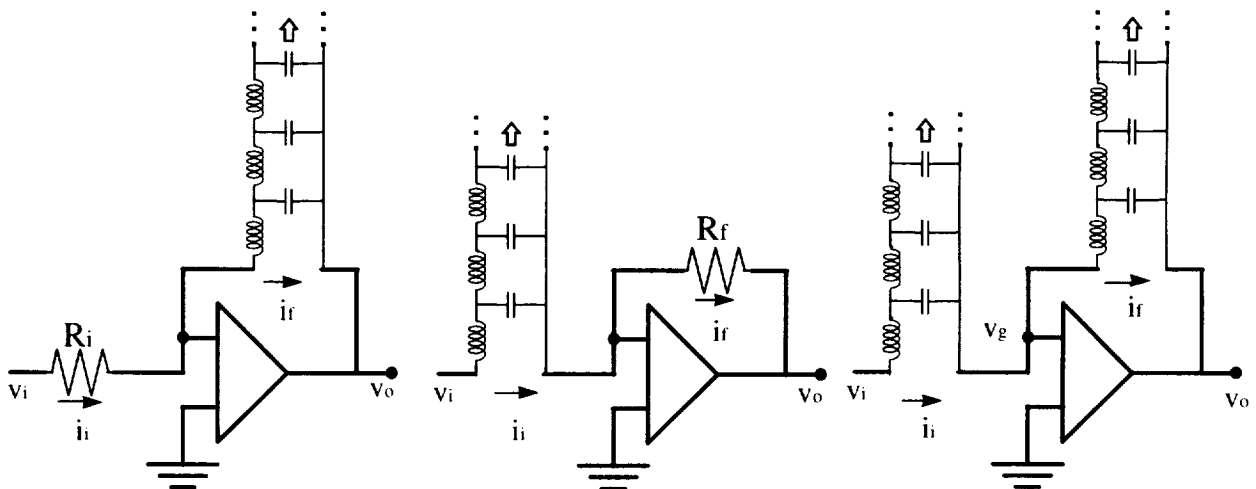

Figure 7-4-2.—Three realizations of the generalized zero order operator.

7.5 Half Order Circuits

7.5.1 Semi-Integrator

The circuit shown in figure 7-5-1 performs the function of semi-integration of the input voltage $v_i(t)$. The component equations are

$$v_i(t) - v_g(t) = i_i(t)R \quad (7.5.1.1)$$

$$v_g(t) - v_o(t) = r\sqrt{\alpha} {}_c D_t^{-1/2} i_f(t), \quad (7.5.1.2)$$

$$\text{where } \psi(i, -1/2, a, c, t) = \frac{1}{r\sqrt{\alpha}} \varphi_1(t), \quad (7.5.1.3)$$

r and α are as defined for equation (7.1.1.3),

$$\text{and } i_i(t) = i_f(t), \quad v_g = 0. \quad (7.5.1.4)$$

Solving for $v_o(t)$

$$v_o(t) = -r\sqrt{\alpha} {}_c D_t^{-1/2} \left\{ \frac{1}{R} v_i(t) \right\}, \text{ then} \quad (7.5.1.5)$$

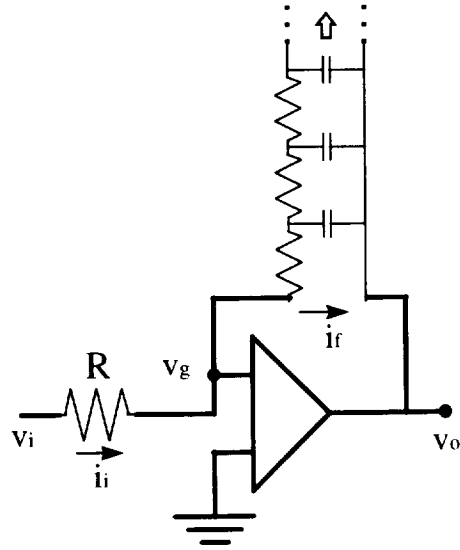

Figure 7-5-1.—Semi-integrator.

$$v_o(t) = -\frac{r\sqrt{\alpha}}{R} {}_c D_t^{-1/2} v_i(t), \quad (7.5.1.6)$$

where

$$\psi(v_i, -1/2, a, c, t) = R\psi(i_f, -1/2, a, c, t) = \frac{R}{r\sqrt{\alpha}} \varphi_1(t). \quad (7.5.1.7)$$

Here equation (7.5.1.6), with the leading coefficient specialized to one, is the basis of the semi-integrator computing element. Note, the equivalent (uninitialized) impedance form may also be readily found from equation (7.1.3.4), because $Z_f = r\sqrt{\alpha} / s^{1/2}$ and, $Z_i = R$, this is given as

$$\frac{v_o(s)}{v_i(s)} = -\frac{r\sqrt{\alpha}}{Rs^{1/2}}. \quad (7.5.1.8)$$

7.5.2 Semi-Differentiator

The circuit of figure 7-5-2 yields an output voltage proportional to the semi-derivative of the input voltage. For this circuit,

$$i_i(t) = \frac{1}{r\sqrt{\alpha}} {}_c D_t^{1/2} (v_i(t) - v_g(t)), \quad (7.5.2.1)$$

where r and α are as defined for equation (7.1.1.3),

$$\psi(v_i - v_g, \frac{1}{2}, a, c, t) = r\sqrt{\alpha} \varphi_2(t), \quad (7.5.2.2)$$

$$v_g(t) - v_o(t) = i_f(t)R, \text{ and} \quad (7.5.2.3)$$

$$i_i(t) = i_f(t), \quad v_g(t) = 0. \quad (7.5.2.4)$$

Then,

$$v_o(t) = -R i_f(t) = -\frac{R}{r\sqrt{\alpha}} {}_c D_t^{1/2} v_i(t) \quad (7.5.2.5)$$

$$\text{and } \psi(v_i, \frac{1}{2}, a, c, t) = \psi(v_i - v_g, \frac{1}{2}, a, c, t) = r\sqrt{\alpha} \varphi_2(t). \quad (7.5.2.6)$$

Here equation (7.5.2.5), with the leading coefficient specialized to one, is the basis of the semi-differentiator computing element. These theoretical circuits then can be used as the basis of an infinite variety of combination circuits. A few of these will be examined to illustrate some of the issues of the earlier theoretical development.

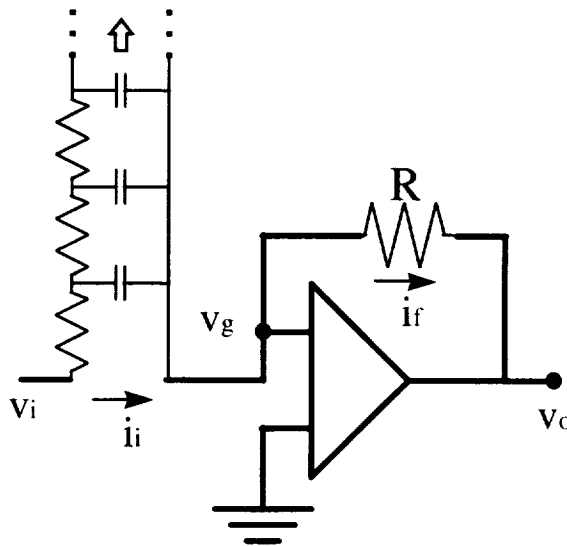

Figure 7-5-2.—Semi-differentiator.

7.6 Combination Circuits

7.6.1 Tandem Semi-Integrators

Consider the circuit shown in figure 7-6-1. For this circuit,

$$v_2(t) = -\frac{r_1 \sqrt{\alpha_1}}{R_1} {}_c D_t^{-1/2} v_1(t), \quad (7.6.1.1)$$

$$\text{with } \psi_1(v_1, -\frac{1}{2}, a, c, t), \text{ and} \quad (7.6.1.2)$$

$$v_3(t) = -\frac{r_2 \sqrt{\alpha_2}}{R_2} {}_c D_t^{-1/2} v_2(t), \quad (7.6.1.3)$$

$$\text{with } \psi_2(v_2, -\frac{1}{2}, a, c, t). \quad (7.6.1.4)$$

Then

$$v_3(t) = \frac{r_1 r_2 \sqrt{\alpha_1 \alpha_2}}{R_1 R_2} {}_c D_t^{-1} v_1(t), \quad (7.6.1.5)$$

$$\text{with } \psi(v_1, -1, a, c, t) = {}_c d_t^{-1/2} \psi_1(v_1, -\frac{1}{2}, a, c, t) - \frac{R_2}{r_2 \sqrt{\alpha_2}} \psi_2(v_2, -\frac{1}{2}, a, c, t). \quad (7.6.1.6)$$

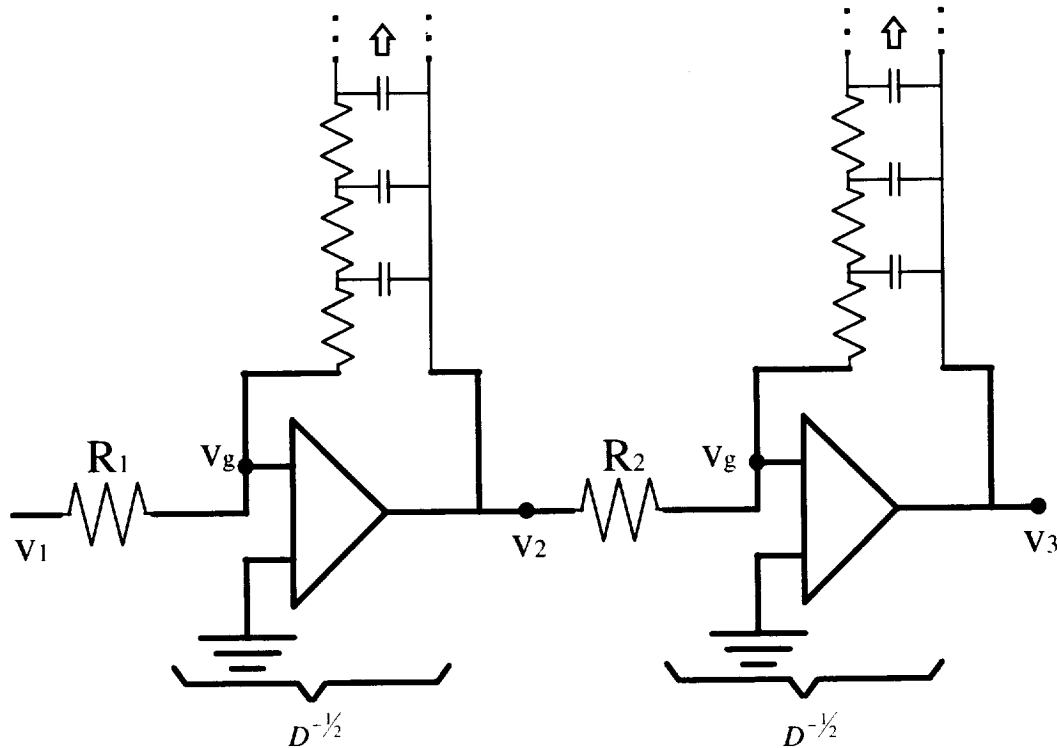

Figure 7-6-1.—Integrator composed of tandem semi-integrators.

7.6.2 Inverse Operations

Consider the circuit shown in figure 7-6-2. For $R_1 = R_2 = r_1 = r_2 = \sqrt{\alpha_1} = \sqrt{\alpha_2} = 1$, the solution is

$$v_3(t) = -{}_c D_t^{1/2} v_2(t) = -{}_c D_t^{1/2} (-{}_c D_t^{-1/2} v_1(t)) = {}_c D_t^0 v_1(t), \quad (7.6.2.1)$$

as expected. Note however, that $v_3(t) = v_1(t)$ only under the condition that

$$\psi(v_1, 0, a, c, t) = {}_c d_t^{1/2} \psi(v_1, -1/2, a, c, t) - \psi(v_2, 1/2, a, c, t) = 0 \quad (7.6.2.2)$$

where $\psi(v_1, 0, a, c, t)$ is the initialization function for the combined operation (i.e., ${}_c D_t^0 v_1(t)$). Under terminal charging, of course this is satisfied. However, under side charging conditions it is seen that $v_3(t) = v_1(t) + \psi(v_1, 0, a, c, t)$ and the zero property is **not** (necessarily) satisfied as indicated previously. It should be clear from this example however that the ability to readily analyze such systems is a perfectly acceptable (indeed desirable) state of affairs.

The discussion will now move away from circuits analogous to generalized calculus operations and consider applications from other areas of engineering and science.

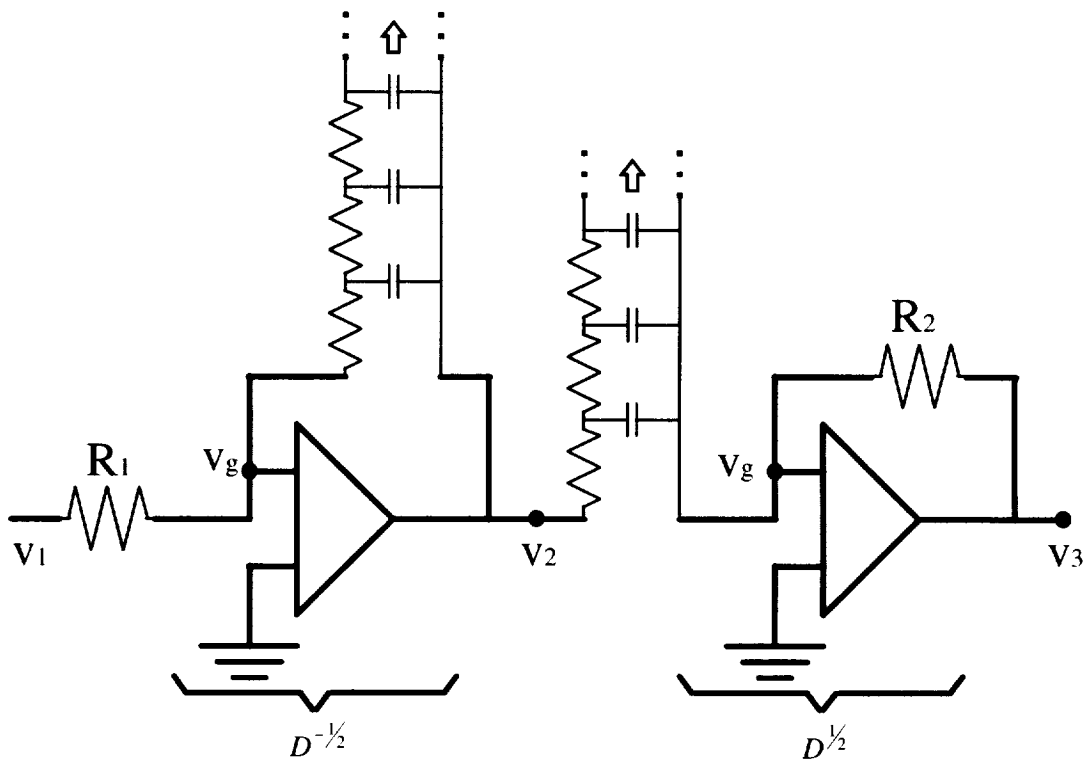

Figure 7-6-2.—Inverse operations using semi-operators.

7.7 Dynamic Thermocouple

It is desired to determine the dynamic (frequency) response of a thermocouple (fig. 7-7-1) that is designed to achieve rapid response. The thermocouple consists of two dissimilar metals with a common junction point. To achieve a high level of dynamic response, the mass of the junction and the diameter of the wire are minimized. Because the wires are long and insulated they will be treated as semi-infinite (heat) conductors. The analysis will determine the transfer function relating the junction temperature to the free stream gas temperature $T_b(s) / T_g(s)$. For the semi-infinite conductors the conducted heat rate $Q(t)$ is given by

$$Q_j(t) = \frac{k_j}{\sqrt{\alpha_j}} {}_c D_t^{1/2} T_b, \quad (7.7.1)$$

where k is the thermal conductivity and α is the thermal diffusivity. For the transfer function the effects of initialization are not required, therefore, all $\psi(t)$'s are zero. Thus the following equations describe the time domain behavior:

$$Q_i(t) = hA(T_g(t) - T_b(t)), \quad (7.7.2)$$

$$T_b(t) = \frac{1}{wc_v} {}_c D_t^{-1} (Q_i(t) - Q_1(t) - Q_2(t)), \quad (7.7.3)$$

$$Q_1(t) = \frac{k_1}{\sqrt{\alpha_1}} {}_c D_t^{1/2} T_b(t), \text{ and} \quad (7.7.4)$$

$$Q_2(t) = \frac{k_2}{\sqrt{\alpha_2}} {}_c D_t^{1/2} T_b(t), \quad (7.7.5)$$

where hA is the product of the convection heat transfer coefficient and the surface area and wc_v is the product of the junction mass and the specific heat of the material. Taking the Laplace transform of these equations, eliminating the Q 's, and collecting like terms yields

$$\left(wc_v s + hA + \frac{k_1}{\sqrt{\alpha_1}} s^{1/2} + \frac{k_2}{\sqrt{\alpha_2}} s^{1/2} \right) T_b(s) = hA T_g(s), \quad (7.7.6)$$

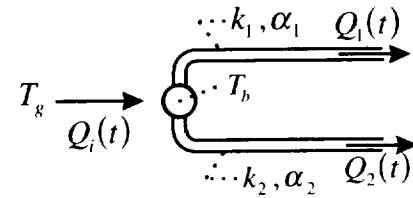

Figure 7-7-1.—Dynamic thermocouple.

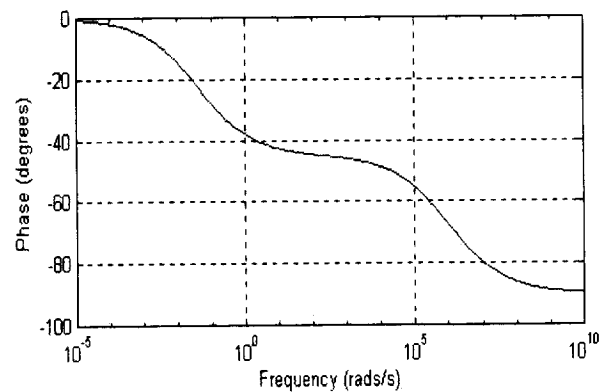
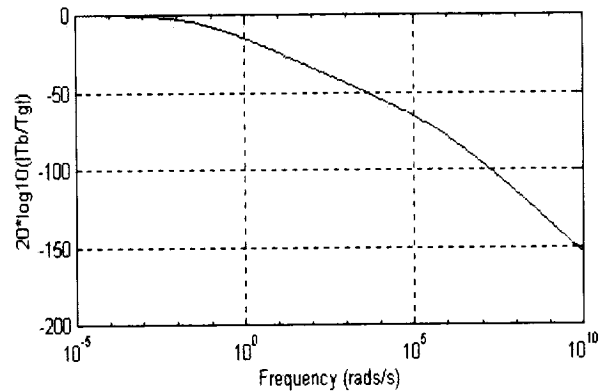

Figure 7-7-2.—Frequency response of dynamic thermocouple.

which gives the transfer function as

$$\frac{T_b(s)}{T_g(s)} = \frac{1}{\left(\frac{wc_v}{hA}\right)s + \frac{1}{hA} \left(\frac{k_1}{\sqrt{\alpha_1}} + \frac{k_2}{\sqrt{\alpha_2}}\right) s^{1/2} + 1} \quad (7.7.7)$$

The magnitude and the phase angle are readily determined by letting $s = i\omega$ and noting that $\sqrt{i} = \cos \pi/4 + i \sin \pi/4$ is the principle value. Figure 7-7-2 shows the transfer function in the form of a Bode plot for

$$\frac{wc_v}{hA} = 0.005 \quad \text{and} \quad \frac{1}{hA} \left(\frac{k_1}{\sqrt{\alpha_1}} + \frac{k_2}{\sqrt{\alpha_2}}\right) = 5.0 .$$

The value of the generalized (fractional) calculus is clearly demonstrated in this application; conventional approaches here would require the solution of two simultaneous partial differential equations with an ordinary differential equation. While this is straightforward, the effort and required attention to detail would be much greater. The response shows two distinct asymptotes; in the mid-frequency range a slope of -10 db/decade corresponds to the $1/s^{1/2}$ behavior and a slope of -20 db/decade for frequencies above 10^6 radians /second corresponds to $1/s$ behavior.

7.8 Electrolytic Cell

The electrolytic cell is well known to exhibit fractional behavior. Typical analysis is based on impedance methods which ignore initialization effects. This example analyzes a simple model of an electrolytic cell (battery) (fig. 7-8-1). The fractional element is a half order system representing the electrode-electrolyte interface. This is a diffusion process and is known in that field as the Warburg impedance or constant phase element (see for example, Bard and Faulkner (1980)). Here we have included an initialization along with the basic properties of the Warburg element. Two phases of behavior are considered: (1) a charging/relaxation phase and (2) a load drawing or usage phase. The charging/relaxation phase takes place between $t = a = 0$ and $t = c$, with actual current flow (electrical charging) only occurring for $a = 0 \leq t \leq b$. Later, in the load drawing phase analysis the desired charging response may be time shifted to set $c = 0$, if that is desired. The end point c , ($c \geq b$), in the charging analysis will be kept variable and may be quickly obtained by setting $t = c$ in the solution equations of this section.

7.8.1 Charging Phase

The time domain equations for the charging/relaxation phase (fig. 7-8-1(a)) are

$$v_1(t) - v_2(t) = \frac{1}{C} \int_0^t i_c(t) dt \quad (7.8.1.1)$$

$$= \frac{1}{C} \int_0^t i_c(t) dt + v_{1-2}(0), \quad (7.8.1.2)$$

$$v_2(t) - v_3(t) = i_R(t)R, \quad (7.8.1.3)$$

$$i_c(t) = i_R(t) + i_W(t), \quad \text{and} \quad (7.8.1.4)$$

$$i_W(t) = \frac{1}{B} {}_0D_t^{1/2} (v_2(t) - v_3(t)). \quad (7.8.1.5)$$

Taking the Laplace transform yields

$$v_1(s) - v_2(s) = \frac{1}{Cs} i_c(s) + \frac{v_{1-2}(0)}{s}, \quad (7.8.1.6)$$

$$v_2(s) - v_3(s) = i_R(s)R, \quad (7.8.1.7)$$

$$i_c(s) = i_R(s) + i_W(s), \quad \text{and} \quad (7.8.1.8)$$

$$i_W(s) = \frac{1}{B} (s^{1/2} (v_2(s) - v_3(s)) + \psi(v_2 - v_3, 1/2, 0, c, s)) \quad (7.8.1.9)$$

Now eliminating the internal variables $i_W(s)$, $i_R(s)$ and $v_2(s)$

and rearranging, yields the following forms

$$i_c(s) = \frac{s(\frac{1}{B}s^{1/2} + \frac{1}{R})}{s + \frac{1}{CB}s^{1/2} + \frac{1}{RC}} (v_1(s) - v_3(s)) + \frac{\frac{1}{B}s\psi(v_2 - v_3, 1/2, 0, c, s) - v_{1-2}(0)(\frac{1}{B}s^{1/2} + \frac{1}{R})}{s + \frac{1}{CB}s^{1/2} + \frac{1}{RC}} \quad (7.8.1.10)$$

$$\text{or} \quad v_1(s) - v_3(s) = \left\{ \frac{s + \frac{1}{CB}s^{1/2} + \frac{1}{RC}}{s(\frac{1}{B}s^{1/2} + \frac{1}{R})} \right\} i_c(s) - \frac{\frac{1}{B}\psi(s)}{\frac{1}{B}s^{1/2} + \frac{1}{R}} + \frac{v_{1-2}(0)}{s}. \quad (7.8.1.11)$$

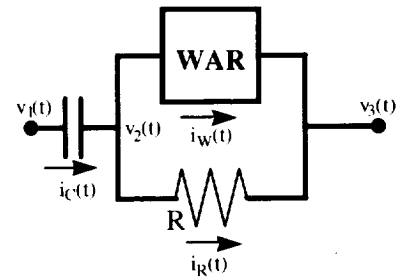

(a) Battery - Charging phase circuit

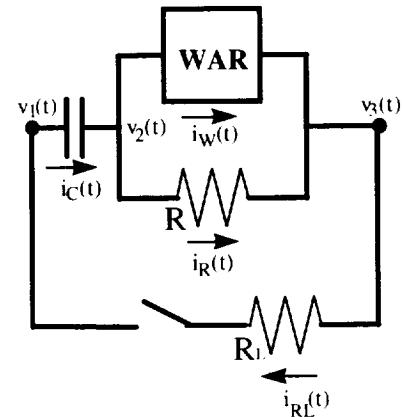

(b) Battery - Load usage phase circuit

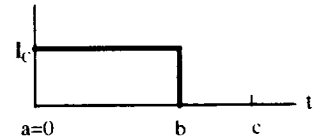

(c) Charging current profile

Figure 7-8-1.—Electrolytic cell circuit.
(a) Charging phase. (b) Load usage phase.
(c) Charging current profile.

These forms can be used either for transfer function analysis or to determine time responses including the effect of initialization. The following transform pairs apply to the forced term of equation (7.8.1.10)

$$L^{-1} \left\{ \frac{B}{s^{1/2} + \frac{B}{R}} \right\} = B \left\{ \frac{1}{\sqrt{\pi t}} - \frac{B}{R} e^{\left(\frac{B}{R}\right)^2 t} \operatorname{erfc}\left(\frac{B}{R} \sqrt{t}\right) \right\}, \quad (7.8.1.11)$$

$$L^{-1} \left\{ \frac{\frac{1}{C}}{s^{1/2} \left(s^{1/2} + \frac{B}{R} \right)} \right\} = \frac{1}{C} e^{\left(\frac{B}{R}\right)^2 t} \operatorname{erfc}\left(\frac{B}{R} \sqrt{t}\right), \quad \text{and} \quad (7.8.1.12)$$

$$L^{-1} \left\{ \frac{\frac{B}{RC}}{s \left(s^{1/2} + \frac{B}{R} \right)} \right\} = \frac{1}{C} \left\{ 1 - e^{\left(\frac{B}{R}\right)^2 t} \operatorname{erfc}\left(\frac{B}{R} \sqrt{t}\right) \right\}. \quad (7.8.1.13)$$

During the initialization period, $0 = a < t \leq c$, both of the initializations are taken as zero. Then, for example, with impulsive charging, $i_c(s) = 1$, and

$$v_1(t) - v_3(t) = \frac{1}{C} + B \left\{ \frac{1}{\sqrt{\pi t}} - \frac{B}{R} e^{\left(\frac{B}{R}\right)^2 t} \operatorname{erfc}\left(\frac{B}{R} \sqrt{t}\right) \right\}. \quad (7.8.1.14)$$

For general $i_c(t)$, the convolution theorem is applied yielding

$$\boxed{v_1(t) - v_3(t) = \int_0^t \left\{ \frac{1}{C} + B \left\{ \frac{1}{\sqrt{\pi \tau}} - \frac{B}{R} e^{\left(\frac{B}{R}\right)^2 \tau} \operatorname{erfc}\left(\frac{B}{R} \sqrt{\tau}\right) \right\} \right\} i_c(t - \tau) d\tau.} \quad (7.8.1.15)$$

This is the solution (response of overall cell voltage to charging current) for the charging phase behavior for a general $i_c(t)$. If the current is taken as a constant during the electrical charging period, $i_c(t) = I_c$, for $0 = a < t \leq b$, then, $i_c(t - \tau) = I_c(u(t - \tau) - u(t - \tau - b))$ (see fig. 7-8-1(c)) and this equation becomes

$$\begin{aligned} v_1(t) - v_3(t) = & \int_0^t \left\{ \frac{1}{C} + B \left\{ \frac{1}{\sqrt{\pi \tau}} - \frac{B}{R} e^{\left(\frac{B}{R}\right)^2 \tau} \operatorname{erfc}\left(\frac{B}{R} \sqrt{\tau}\right) \right\} \right\} I_c d\tau \\ & - u(t - b) \int_0^{t-b} \left\{ \frac{1}{C} + B \left\{ \frac{1}{\sqrt{\pi \tau}} - \frac{B}{R} e^{\left(\frac{B}{R}\right)^2 \tau} \operatorname{erfc}\left(\frac{B}{R} \sqrt{\tau}\right) \right\} \right\} I_c d\tau, \quad t > 0. \end{aligned} \quad (7.8.1.16)$$

The above integrals are readily evaluated since

$$\int_0^t e^{E\tau} \operatorname{erfc}(\sqrt{E\tau}) d\tau = \frac{1}{B} \left[e^{Et} \operatorname{erfc}(\sqrt{Et}) - 1 \right] + \frac{2}{\sqrt{\pi}} \sqrt{Et}, \quad (7.8.117)$$

(see for example, Spanier and Oldham (1987)), thus,

$$v_1(t) - v_3(t) = I_c \left[\frac{t}{C} + 2B\sqrt{\frac{t}{\pi}} - \frac{R}{B} \left\{ e^{\left(\frac{B}{R}\right)^2 t} \operatorname{erfc}\left(\frac{B\sqrt{t}}{R}\right) - 1 + \frac{2}{\sqrt{\pi}} \left(\frac{B\sqrt{t}}{R}\right) \right\} \right] - I_c u(t-b) \left[\frac{t-b}{C} + 2B\sqrt{\frac{t-b}{\pi}} - \frac{R}{B} \left\{ e^{\left(\frac{B}{R}\right)^2 (t-b)} \operatorname{erfc}\left(\frac{B\sqrt{t-b}}{R}\right) - 1 + \frac{2}{\sqrt{\pi}} \left(\frac{B\sqrt{t-b}}{R}\right) \right\} \right], \quad t > 0. \quad (7.8.118)$$

The voltage response $v_1(t) - v_3(t)$ of the battery during the electrical charging period $0 < t < b = 1$ and during the relaxation period $t > 1$ are shown in figure 7-8-2. Also shown is the voltage response of the Warburg element $v_2(t) - v_3(t)$ (determined in subsection 7.8.2). The battery parameters are taken to be $R = B = C = 1.0$.

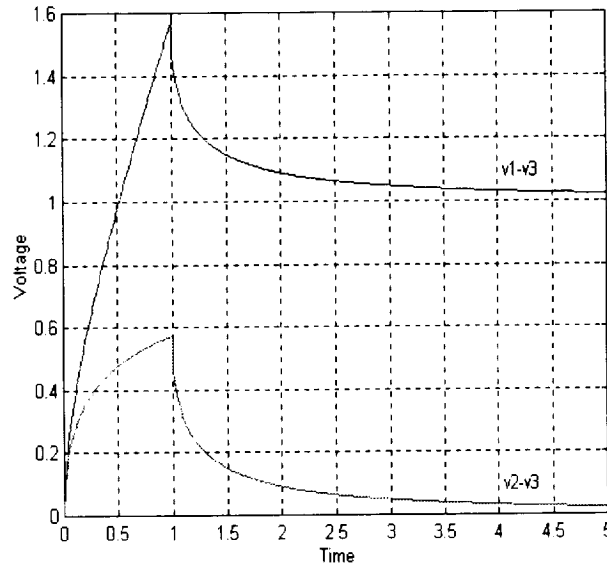

Figure 7-8-2.—Voltage response with time for electrolytic cell-charging and relaxation phases.

7.8.2 Initialization Function

The above response (eq. (7.8.1.16) or (7.8.1.18)) then can be the basis for a “good” mathematical form for an initialization function for systems (cells) of this type with constant current charging. It of course includes both the effects of the Warburg element and the capacitor. These may be separated as follows. Since $v_{1-2}(0)$ must be zero, the voltage across the Warburg element $v_2(t) - v_3(t)$, is determined as

$$\begin{aligned} v_2(t) - v_3(t) &= (v_1(t) - v_3(t)) - (v_1(t) - v_2(t)) = (v_1(t) - v_3(t)) - \frac{1}{C} \int_0^t i_c d\tau, \quad t > 0, \\ &= (v_1(t) - v_3(t)) - \frac{1}{C} \int_0^t I_c (\mathcal{U}(\tau) - \mathcal{U}(\tau - b)) d\tau, \end{aligned}$$

which using equation (7.8.1.16), yields

$$\begin{aligned} &= \int_0^t B \left\{ \frac{1}{\sqrt{\pi\tau}} - \frac{B}{R} e^{\left(\frac{B}{R}\right)^2 \tau} \operatorname{erfc}\left(\frac{B\sqrt{\tau}}{R}\right) \right\} I_c d\tau - \\ &\quad \mathcal{U}(t-b) \int_0^{t-b} B \left\{ \frac{1}{\sqrt{\pi\tau}} - \frac{B}{R} e^{\left(\frac{B}{R}\right)^2 \tau} \operatorname{erfc}\left(\frac{B\sqrt{\tau}}{R}\right) \right\} I_c d\tau, \quad t > 0. \end{aligned} \quad (7.8.2.1)$$

This is the voltage across the Warburg element during the charging period. Note, this equation also applies for $t > c$ with an open external circuit. The input function to (argument of) the semi-derivative of the Warburg impedance is $(v_2(t) - v_3(t))$. If it is assumed that the Warburg impedance is terminally charged, then the initialization function for the Warburg element may be determined from equation (6.3.3), namely,

$$\psi(f, u, a, c, t) = \frac{d^m}{dt^m} \psi(f, -p, a, c, t) + \psi(h, m, a, c, t). \quad (6.3.3)$$

Because terminal charging is assumed $\psi(h, 1, a, c, t) = 0$, thus,

$$\psi_{WAR}(v_2 - v_3, \frac{1}{2}, a, c, t) = \frac{1}{\Gamma(\frac{1}{2})} \frac{d}{dt} \int_a^c (t - \tau)^{\frac{1}{2}-1} (v_2(\tau) - v_3(\tau)) d\tau, \quad t > c. \quad (7.8.2.2)$$

This then is a “good” initialization of the Warburg element in the context of this electrical configuration and charging profile. This initialization applies for $t > c \geq b \geq a = 0$. In its application, if it is desired to initialize with $c = 0$, then it would be necessary to time shift this result appropriately, that is, replace t by $t - c$ in equation (7.8.2.1). Shown here is the formal approach to determination of the initialization function. In the next section, material creep, an alternate approach, which is sometimes useful, will be shown.

7.8.3 Load Drawing Phase

Consider now the load phase behavior of the electrolytic cell as shown in figure 7-8-1(b). The defining equations are amended to reflect the added external load resistance.

$$v_1(t) - v_2(t) = \frac{1}{C} {}_c D_t^{-1} i_c(t) = \frac{1}{C} \int_c^t i_c(t) dt + v_{1-2}(c), \quad (7.8.3.1)$$

$$v_2(t) - v_3(t) = i_R(t) R, \quad (7.8.3.2)$$

$$i_c(t) = i_R(t) + i_w(t) = i_{RL}(t), \quad (7.8.3.3)$$

$$v_3(t) - v_1(t) = i_{RL}(t) R_L, \quad \text{and} \quad (7.8.3.4)$$

$$i_w(t) = \frac{1}{B} {}_c D_t^{1/2} (v_2(t) - v_3(t)). \quad (7.8.3.5)$$

Taking the Laplace transform yields

$$v_1(s) - v_2(s) = \frac{1}{Cs} i_c(s) + \frac{v_{1-2}(c)}{s}, \quad (7.8.3.6)$$

$$v_2(s) - v_3(s) = i_R(s) R, \quad (7.8.3.7)$$

$$i_c(s) = i_R(s) + i_w(s) = i_{RL}(s), \quad (7.8.3.8)$$

$$v_3(s) - v_1(s) = i_{RL}(s) R_L, \quad \text{and} \quad (7.8.3.9)$$

$$i_w(s) = \frac{1}{B} \left(s^{1/2} (v_2(s) - v_3(s)) + \psi_{WAR}(v_2 - v_3, 1/2, 0, c, s) \right). \quad (7.8.3.10)$$

Then from the charging analysis, equation (7.8.1.10), with $i_c(s) = i_{RL}(s) = (v_3(s) - v_1(s)) / R_L$, and taking $a = 0$, and $c = 1$,

$$v_1(s) - v_3(s) = \left(\frac{R_L s \left(\frac{s^{1/2}}{B} + \frac{1}{R} \right)}{R_L \frac{s^{1/2}}{B} + \left(1 + \frac{R_L}{R} \right) s + \frac{1}{CB} s^{1/2} + \frac{1}{RC}} \right) \left(\frac{v_{1-2}(1)}{s} - \frac{\psi_{WAR}(v_2 - v_3, 1/2, 0, 1, s)}{B \left(\frac{s^{1/2}}{B} + \frac{1}{R} \right)} \right). \quad (7.8.3.11)$$

This response is seen to have no forced term and two initialization driven terms. These are the initialization effect of the capacitor, i.e., the $v_{1-2}(1)$ term, and the historic effect of the Warburg impedance as reflected in the ψ_{WAR} term. It is readily analyzed using the following transformation, let $p = s^{1/2} \Rightarrow p^2 = s$, $p^3 = s^{3/2}$, then

$$v_1(p) - v_3(p) = \left(\frac{p^2 \left(p + \frac{B}{R} \right)}{p^3 + \frac{B}{R_L} \left(1 + \frac{R_L}{R} \right) p^2 + \frac{1}{R_L C} p + \frac{B}{RR_L C}} \right) \left(\frac{v_{1-2}(1)}{p^2} + \frac{\frac{1}{B} \psi(v_2 - v_3, 1/2, 0, 1, p^2)}{\frac{p}{B} + \frac{1}{R}} \right). \quad (7.8.3.12)$$

From this point, an appropriate substitution or approximation is made for $\psi(p^2)$, and conventional analysis tools (factoring, partial fractions, etc.) are applied to evaluate the p domain response. This response may be transformed back to the s domain and subsequently inverse Laplace transformed back to the time domain if desired. This is expedited by the use of special transforms, which will be presented in a later paper.

7.9 Material Creep

7.9.1 Creep Strain

Creep behavior of materials may be described and analyzed using the methods of fractional calculus. A stress-strain law for certain viscoelastic materials has been suggested by G.W. Scott-Blair (see Bland (1960) p. 5). It neglects both the instantaneous elastic and the long term viscous flow effects. The relationship in terms of this paper is given by

$$\varepsilon(t) = \frac{1}{K} {}_c D_t^{-\nu} \sigma(t) \quad (7.9.1.1)$$

or, when the specimen is new, no initialization is required hence,

$$\varepsilon(t) = \frac{1}{K} {}_a d_t^{-\nu} \sigma(t). \quad (7.9.1.2)$$

Here ε and σ are the strain and stress respectively. K and ν are constants associated with the material, $\nu = 0$ for an elastic solid, and $\nu = 1$ for a viscous liquid.

Consider a uniform stress load to be applied between times $t = 0$ and $t = d$, on a new specimen (no initialization) then,

$$\sigma(t) = \kappa [H(t) - H(t-d)], \quad (7.9.1.3)$$

where H is the unit step function, and κ is the magnitude of the load.

Then,

$$\varepsilon(t) = \frac{\kappa}{K\Gamma(\nu)} \int_0^t (t-\tau)^{\nu-1} [H(\tau) - H(\tau-d)] d\tau, \quad (7.9.1.4)$$

$$= \frac{\kappa}{K\Gamma(\nu)} \left[\int_0^t (t-\tau)^{\nu-1} d\tau H(t) - \int_d^t (t-\tau)^{\nu-1} d\tau H(t-d) \right], \quad \text{and} \quad (7.9.1.5)$$

$$= \frac{\kappa}{K\Gamma(\nu+1)} \left[t^\nu H(t) - (t-d)^\nu H(t-d) \right], \quad (7.9.1.6)$$

defines the strain (creep) response for the prescribed loading. The effect of ν is shown in figure

7-9-1, where normalized strain (creep) is $\frac{K\Gamma(\nu+1)}{\kappa} \varepsilon(t)$. The response $\varepsilon(t)$ for $t < d = 1$, is

seen to be essentially the creep function. The response for $t > d = 1$ is the stress relaxation period.

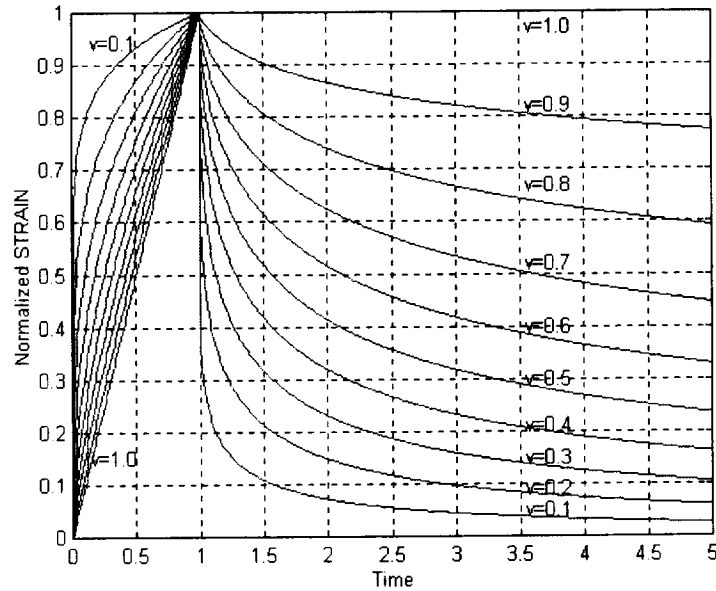

Figure 7-9-1.—Creep (strain) versus time for various ν . [$\nu = \nu$ in figure]

7.9.2 Creep Initialization

For creep applications of this type the initialization function associated with constant past loading may be readily inferred from the solution for equation (7.9.1.6), as follows.

Consider any problem initialized at point c , then,

$${}_c D_t^{-q} f(t) = {}_a D_t^{-q} f(t), \quad t > c, \quad (7.9.2.1)$$

$${}_c d_t^{-q} f(t) + \psi(f, -q - a, c, t) = {}_a D_t^{-q} f(t) = {}_a d_t^{-q} f(t), \quad t > c, \quad (7.9.2.2)$$

thus ψ may be expressed as

$$\psi(f, -q, a, c, t) = {}_a d_t^{-q} f(t) - {}_c d_t^{-q} f(t), \quad t > c. \quad (7.9.2.3)$$

It is now desired to obtain an initialization function for the creep problem initialized at $t = c = d$ where d is as used in equation (7.9.1.6). Applying this result, equation (7.9.2.3), to the creep problem gives

$${}_c D_t^{-\nu} \sigma(t) = {}_c d_t^{-\nu} \sigma(t) + \psi(\sigma, -\nu, a, c, t), \quad t > c. \quad (7.9.2.4)$$

Then taking $c = d$ and since $\sigma(t) = 0$ for $t > d$,

$${}_c d_t^{-\nu} \sigma(t) = {}_a d_t^{-\nu} \sigma(t) = 0, \quad t > c = d, \quad (7.9.2.5)$$

and K times the response equation (7.9.1.6) is the initialization $\psi(t)$ thus,

$$\psi(\sigma, -\nu, a, c, t) = \frac{K}{\Gamma(\nu+1)} \left[t^\nu H(t) - (t-c)^\nu H(t-c) \right], \quad t > c = d. \quad (7.9.2.6)$$

This initialization function may now (with proper time shifting) be used for specimens which have experienced a creep history.

7.9.3 Relaxation Function

The stress (creep) relaxation function $\chi(t)$ is defined as the stress required to produce a strain $H(t)$, excluding terms that are initially infinite or do not tend to zero as t becomes infinite (Bland (1960) p. 38). This is easily determined in the fractional setting. For a new material, the stress is given by

$$\chi(t) = \sigma(t) = K_a d_t^\nu \varepsilon(t) = K_a d_t^1 d_t^{-(1-\nu)} \varepsilon(t), \quad (7.9.3.1)$$

$$= K \frac{d}{dt} \frac{1}{\Gamma(1-\nu)} \int_0^t (t-\tau)^{-\nu} H(\tau) d\tau, \quad (7.9.3.2)$$

$$\chi(t) = \frac{K}{\Gamma(1-\nu)} t^{-\nu} H(t), \quad (7.9.3.3)$$

yielding as a result the creep relaxation function for this formulation.

7.10 Fractional Order Tracking Filter

The availability of fractional differintegrals allows new freedoms in many areas, tracking filters is but one example. Here a noisy signal $x(t)$ is to be filtered to yield the filtered signal $y(t)$. Only a single active element will be considered here, then the filter is described by

$$({}_0D_t^q + a)y(t) = a x(t) \quad (7.10.1)$$

or

$${}_0d_t^q y(t) + \psi(y, q, 0, c, t) + a y(t) = a x(t). \quad (7.10.2)$$

Taking the Laplace transform yields

$$s^q y(s) + \psi(s) + a y(s) = a x(s) \quad (7.10.3)$$

or

$$y(s) = \frac{a}{s^q + a} x(s) - \frac{\psi(s)}{s^q + a}. \quad (7.10.4)$$

While the ψ function may allow the possibility of “precharging” the filter to minimize the filter lag, the initialization function in this application will be discarded. The transfer function of the filter then is given by

$$\frac{y(s)}{x(s)} = \frac{a}{s^q + a}. \quad (7.10.5)$$

Then the behavior of the filter can be considered by studying the response to a unit step in $x(t)$ thus,

$$y(s) = \frac{a}{s(s^q + a)}. \quad (7.10.5)$$

The full range $0 \leq q \leq 1$ is of course available, and requires a series solution for the inverse transform. This will not be detailed here, but time responses for a step input for $x(t)$ showing the effects of varying both a and q are presented in figure 7-10-1. The inverse transform for the special case $q = \frac{1}{2}$ is readily shown as

$$y(t) = 1 - e^{-a^2 t} \operatorname{Erfc}(a t^{1/2}). \quad (7.10.6)$$

The frequency response for the tracking filter (eq. (7.10.5)) for various q with $a = 1$, is presented in figure 7-10-2.

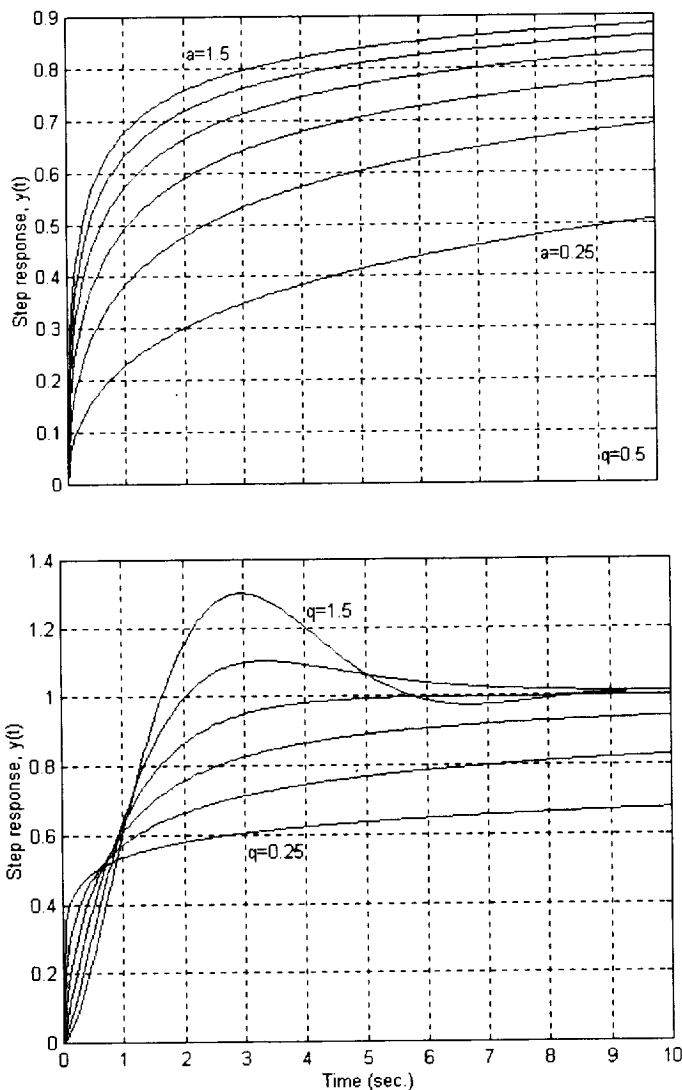

Figure 7-10-1.—Fractional order tracking filter response to unit step input, varying q ($a = 1$) and varying a ($q = 0.5$).

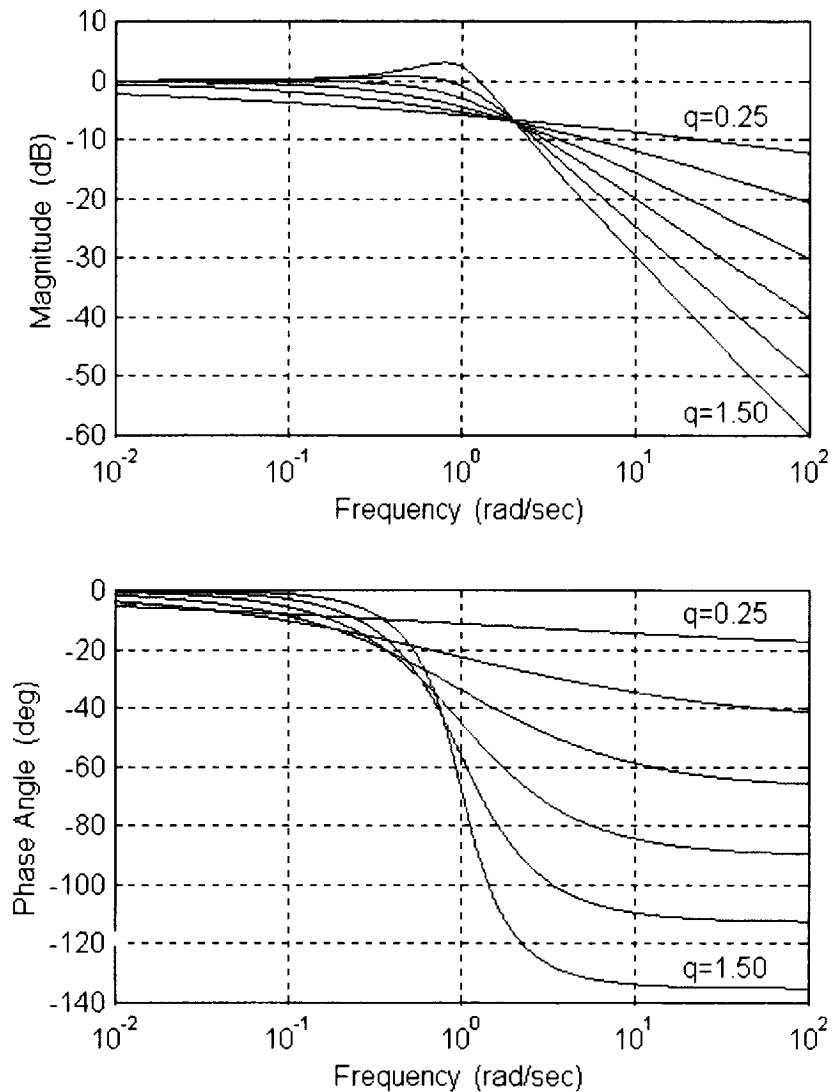

Figure 7-10-2.—Fractional order tracking filter frequency response, varying q and $a = 1.0$.

7.11 Viscoelastic Damped Vibration

The addition of damping is important in many applications for stability augmentation. One such application in the aerospace field is damping augmentation for gas turbine fan blades. The vibration modes in this case are typically bending, torsion, or combinations. Here it is desired to determine the analogous linear vibration mode behavior. The viscoelastic damping may be added in different ways. The interest here is in determining the transfer function (s domain response) in general terms, then, by specialization of the constants, various cases may be examined.

Since the transfer function requires the initializations to be zero, the equations describing the generalized system (fig. 7-11-1) are

$$F_1 = -k_1 \, {}_0d_t^{q1} (x_0 - x_{m1}), \quad (7.11.1)$$

$$F_1 = k (x_{m1} - x_i), \quad (7.11.2)$$

$$F_2 = -k_2 \, {}_0d_t^{q2} (x_0 - x_{m2}), \quad (7.11.3)$$

$$F_2 = k_3 \, {}_0d_t^{q3} (x_{m2} - x_i), \quad \text{and} \quad (7.11.4)$$

$$F_1 + F_2 = m \, {}_0d_t^2 x_0. \quad (7.11.5)$$

Where the k 's are damping coefficients and the spring constant, and m, F , and x are the mass, force and displacements respectively.

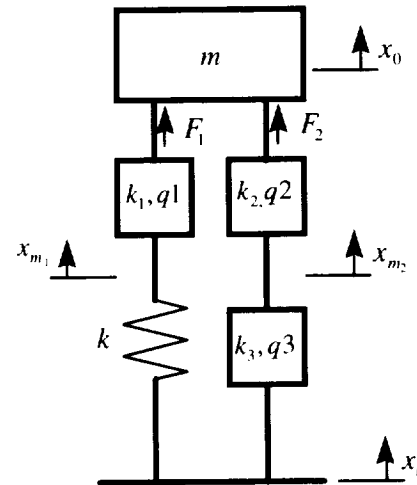

Figure 7-11-1.—Spring-mass-visco damped dynamic system.

Taking the Laplace transform of these equations and eliminating x_{m1} and x_{m2} yields

$$F_1(s) = \left(\frac{-k_1 s^{q1}}{1 + \frac{k_1}{k} s^{q1}} \right) (x_0 - x_i) \quad \text{and} \quad F_2(s) = \left(\frac{-k_2 s^{q2}}{1 + \frac{k_2}{k_3} s^{q2-q3}} \right) (x_0 - x_i). \quad (7.11.6)$$

Then after eliminating the forces and some algebra the generalized transfer function is obtained as

$$\frac{x_0(s)}{x_i(s)} = \frac{\frac{1}{k_2} s^{q1+q3} + \frac{1}{k_3} s^{q1+q2} + \frac{1}{k_1} s^{q2+q3} + \frac{1}{k} s^{q1+q2+q3}}{\frac{m}{k_1 k_2} s^{2+q3} + \frac{m}{k k_2} s^{2+q1+q3} + \frac{m}{k_1 k_3} s^{2+q2} + \frac{m}{k k_3} s^{2+q1+q2} + \frac{1}{k_2} s^{q1+q3} + \frac{1}{k_3} s^{q1+q2} + \frac{1}{k_1} s^{q2+q3} + \frac{1}{k} s^{q1+q2+q3}}. \quad (7.11.7)$$

Now various special cases may be examined by appropriate choices for k, k_i , and the q 's. For example, to allow damper 3 to represent a conventional (dashpot) damper, let $q3 = 1$ and select the appropriate k_3 . Here, for simplicity, the $q1$ and $q2$ dampers will be eliminated (made into springs of infinite stiffness), that is, $q1 = q2 = 0$, and $k_1 = k_2 = \infty$, and the $q3$ damper will be considered to be viscoelastic (i.e., fractional value for $q3$); then the transfer function for figure 7-11-1 is given as

$$\frac{x_0(s)}{x_i(s)} = \frac{\frac{k_3}{m} s^{q3} + \frac{k}{m}}{s^2 + \frac{k_3}{m} s^{q3} + \frac{k}{m}}. \quad (7.11.8)$$

The frequency response may now be evaluated by letting $s = i\omega$ and determining the magnitude and phase angle (polar form argument) using equation (7.11.8). The results for $k/m = 1$ and various values of k_3/m and q_3 are shown in figures 7-11-2 and 7-11-3.

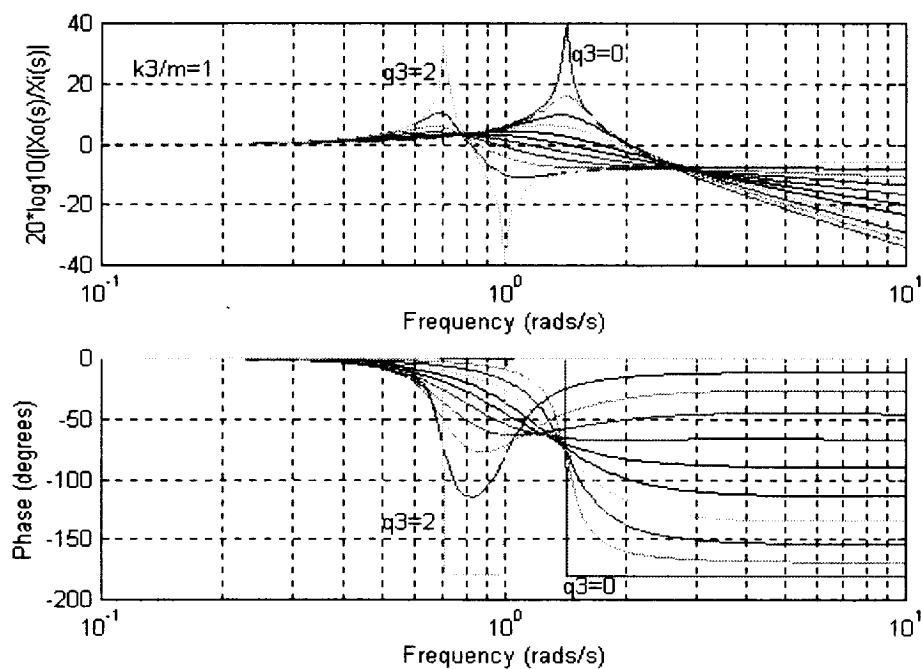

Figure 7-11-2.—Mass-spring-viscoelastic damper transfer function, varying q_3 the viscoelastic coefficient from 0 to 2 by steps of 0.2.

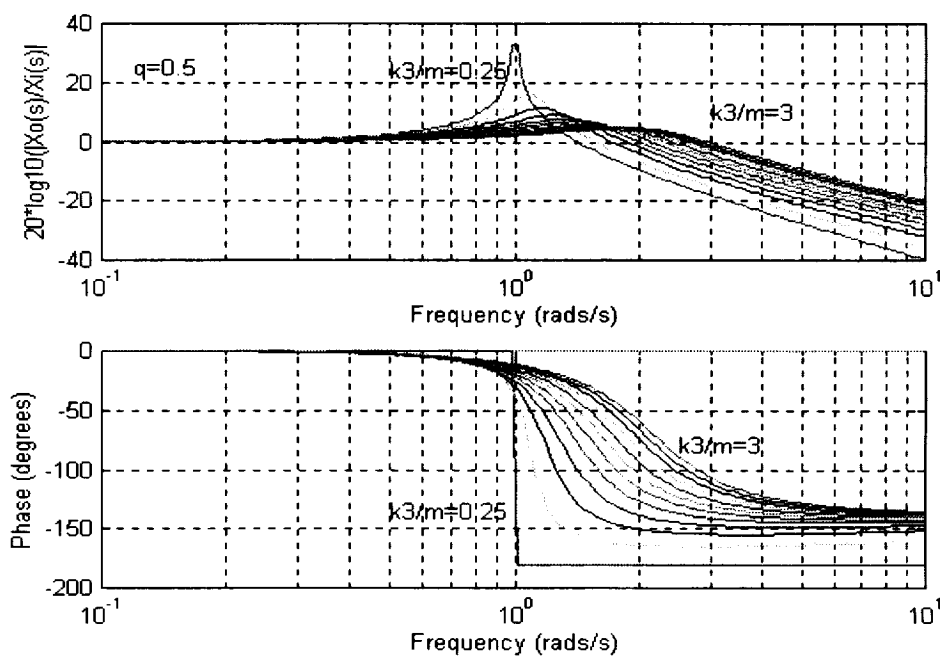

Figure 7-11-3.—Mass-spring-viscoelastic damper transfer function k_3/m varies from 0.25 to 3 by steps of 0.25, $q_3 = 0.5$.

8. Variable Structure (Order) Differintegral

8.1 Variable Order Integration

8.1.1 Research Issues

This section presents some research questions which have been enabled by the fractional calculus. Consider the fractional differential equation

$${}_c D_t^q y(t) = f(t) \quad (8.1.1.1)$$

and the inferred integral equation

$${}_c D_t^{-q} f(t) = y(t). \quad (8.1.1.2)$$

Since q in the fractional calculus can take on any real (or complex) value, the question is asked, *What is a desirable definition for the fractional integral when q is allowed to vary either with t or y ? More specifically, What is an appropriate definition for*

$${}_c D_t^{-q(t,y)} f(t)? \quad (8.1.1.3)$$

8.1.2 Motivation

There is considerable potential physical motivation toward the creation and implementation of such a concept. A few possibilities will be mentioned here.

From the field of viscoelasticity (Bland (1960)), the effect of temperature on the small amplitude creep behavior (force/extension) of certain materials is to change the characteristics from elastic (spring-like, $q \cong 0$) to viscoelastic or viscous (damper-like, $q \cong -1$). This relates to the expression

$${}_c D_t^{-q} F(t) = k(x_a(t) - x_b(t)), \quad (8.1.2.1)$$

where F is force and x is displacement. Experience (and experiments), typically, is based on fixed temperature, but real applications may well require a time varying temperature to be analyzed.

Glöckle and Nonnenmacher (1995) studied the relaxation processes and reaction kinetics of proteins which are described by fractional differential equations of order β . The order was found to have a temperature dependence. (It is interesting to note that this work also alludes to difficulties which appear to be related to initialization).

Smit, W. and deVries (1970) studied the stress-strain behavior of viscoelastic materials (textile fibers) with fractional order differential equations of order α , with $1 \geq \alpha \geq 0$. They show, based on related experiments, α to be dependent on strain level.

Polymer linear viscoelastic stress relaxation was studied by Bagley (1991). This process is described by fractional differential equations of order β for a given fixed temperature. The paper

shows a clear dependence of β on temperature for polyisobutlene and correlates fractional model and experiment. Further, it is indicated that β order fractal time processes lead to β order fractional derivative constitutive laws.

From the field of damage modeling, as the damage accumulates (with time) in a structure the nonlinear stress / strain behavior changes. It may be that this is better described with variable order calculus.

Finally, the behavior of some diffusion processes in response to temperature changes may be better described using variable order elements than time varying coefficients.

8.1.3 Analysis

For present purposes, attention will be focused only on variations of q with t , that is, $q = q(t)$. Further, initialization will not be considered to start, and the Riemann-Liouville definition will be taken as the basis (see Appendix C for Grünwald variable structure basis discussion). For simplicity in these considerations $c = 0$ and $\psi(f, -q(t), a, c, t) = 0$. The most general form then under consideration is

$${}_0D_t^{-q(t)} f(t) \equiv \int_0^t \frac{(t-\tau)^{q_e(t,\tau)-1}}{\Gamma(q_g(t,\tau))} f(\tau) d\tau, \quad (8.1.3.1)$$

where the notation $q_e(t, \tau)$ and $q_g(t, \tau)$ have been used to indicate that the arguments of the q 's of the exponent and the gamma function may be different. The simplest arguments to be considered are $q(t, \tau) \rightarrow q(t)$, $q(t, \tau) \rightarrow q(\tau)$ and $q(t, \tau) \rightarrow q(t - \tau)$. For the two occurrences of q in the defining integral (eq. (8.1.3.1)), this yields 9 permutations to be studied. To quickly screen these possibilities and more, computer simulations of the defining integrals (with a variety of test functions, $f(t)$'s) were used to quickly eliminate potential definitions with unsatisfactory properties. The desirable properties, of course, are those contained in the criteria examined earlier. Clearly backward compatibility, and the zero properties are not issues for definitions which are special cases of equation (8.1.3.1). This leaves linearity and the index law (composition) to be considered.

8.1.4 Criteria

Linearity will be considered first using the general form, equation (8.1.3.1). Then,

$${}_0D_t^{-q(t)} (a f(t) + b g(t)) = \int_0^t \frac{(t-\tau)^{q_e(t,\tau)-1}}{\Gamma(q_g(t,\tau))} \{a f(\tau) + b g(\tau)\} d\tau, \quad (8.1.4.1)$$

$$= a \int_0^t \frac{(t-\tau)^{q_e(t,\tau)-1}}{\Gamma(q_g(t,\tau))} f(\tau) d\tau + b \int_0^t \frac{(t-\tau)^{q_e(t,\tau)-1}}{\Gamma(q_g(t,\tau))} g(\tau) d\tau, \quad (8.1.4.2)$$

$$= a {}_0D_t^{-q(t)} f(t) + b {}_0D_t^{-q(t)} g(t). \quad (8.1.4.3)$$

Therefore linearity is satisfied for all arguments of q in the defining integral.

The computer simulation showed that the interesting behavior occurred when $q_e(t, \tau) = q_s(t, \tau)$. Of these three cases only the case $q(t, \tau) \rightarrow q(t - \tau)$ provided adherence to the index law (for selected functions); but it did not satisfy composition, namely, under the definition

$${}_0 D_t^{-q(t)} f(t) \equiv \int_0^t \frac{(t - \tau)^{q(t-\tau)-1}}{\Gamma(q(t-\tau))} f(\tau) d\tau \quad (8.1.4.4)$$

it was inferred that

$${}_0 D_t^{-q(t)} {}_0 D_t^{-v(t)} f(t) = {}_0 D_t^{-v(t)} {}_0 D_t^{-q(t)} f(t) \neq {}_0 D_t^{-q(t)-v(t)} f(t). \quad (8.1.4.5)$$

It is observed that this definition is a convolutional form. The convolution character of the generalized integral will now be used in proving the above property; indeed the property is fully equivalent to the associative law for convolution integrals (see Mikuzinski (1967)).

The index law will now be proved. The LHS of equation (8.1.4.5), under the definition of equation (8.1.4.4), is

$${}_0 D_t^{-q(t)} {}_0 D_t^{-v(t)} f(t) = \int_0^t \frac{(t - \tau)^{q(t-\tau)-1}}{\Gamma(q(t-\tau))} \int_0^\tau \frac{(\tau - s)^{v(\tau-s)-1}}{\Gamma(v(\tau-s))} f(s) ds d\tau. \quad (8.1.4.6)$$

Replacing the outer integral with its convolution equivalent yields

$$= \int_0^t \frac{\tau^{q(\tau)-1}}{\Gamma(q(\tau))} \int_0^{t-\tau} \frac{(t - \tau - s)^{v(t-\tau-s)-1}}{\Gamma(v(t-\tau-s))} f(s) ds d\tau; \quad (8.1.4.7)$$

letting $s = \omega - \tau \Rightarrow ds = d\omega$,

$$= \int_0^t \frac{\tau^{q(\tau)-1}}{\Gamma(q(\tau))} \int_\tau^t \frac{(t - \omega)^{v(t-\omega)-1}}{\Gamma(v(t-\omega))} f(\omega - \tau) d\omega d\tau, \quad (8.1.4.8)$$

$$= \int_0^t \int_\tau^t \frac{\tau^{q(\tau)-1} (t - \omega)^{v(t-\omega)-1}}{\Gamma(q(\tau)) \Gamma(v(t-\omega))} f(\omega - \tau) d\omega d\tau. \quad (8.1.4.9)$$

The double integral is extended to the triangular region as shown in figure 8-1-1, yielding

$$= \iint_{\tau} \frac{\tau^{q(\tau)-1} (t - \omega)^{v(t-\omega)-1}}{\Gamma(q(\tau)) \Gamma(v(t-\omega))} f(\omega - \tau) d\omega d\tau. \quad (8.1.4.10)$$

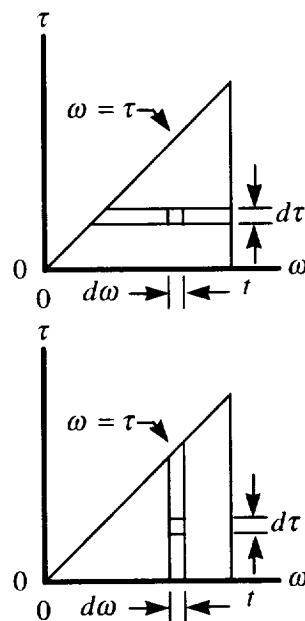

Figure 8-1-1.—Reference triangular region.

Now the double integral is converted back to an iterated integral with the order of integration reversed, giving

$$= \int_0^t \frac{(t - \omega)^{v(t-\omega)-1}}{\Gamma(v(t-\omega))} \int_0^\omega \frac{\tau^{q(\tau)-1}}{\Gamma(q(\tau))} f(\omega - \tau) d\tau d\omega. \quad (8.1.4.11)$$

The inner integral is now replaced with its convolutional equivalent

$$= \int_0^t \frac{(t-\omega)^{v(t-\omega)-1}}{\Gamma(v(t-\omega))} \int_0^\omega \frac{(\omega-\tau)^{q(\omega-\tau)-1}}{\Gamma(q(\omega-\tau))} f(\tau) d\tau d\omega, \quad (8.1.4.12)$$

$$= {}_0D_t^{-v(t)} {}_0D_t^{-q(t)} f(t) \quad (8.1.4.13)$$

which completes the proof. At this time the definition of equation (8.1.4.4) appears to be the most satisfactory definition in terms of these properties and its strong relationship to convolution theory. It is noted explicitly that composition is *not* satisfied, that is, that

$${}_0D_t^{-q(t)} {}_0D_t^{-v(t)} f(t) = {}_0D_t^{-v(t)} {}_0D_t^{-q(t)} f(t) \neq {}_0D_t^{-q(t)-v(t)} f(t). \quad (8.1.4.14)$$

However, the lack of this computational convenience does not diminish the potential usefulness of this concept for application in the physical sciences. It would however, considerably increase the analytical difficulty.

It should be noted that the definition

$${}_0D_t^{-q(t)} f(t) \equiv \int_0^t \frac{(t-\tau)^{q(t)-1}}{\Gamma(q(t))} f(\tau) d\tau \quad q(t) > 0 \quad (8.1.4.15)$$

can be shown to have a weak form of composition, namely,

$${}_0D_t^{-u(t)} {}_0D_t^{-k} f(t) = {}_0D_t^{-(u(t)+k)} f(t) \neq {}_0D_t^{-k} {}_0D_t^{-u(t)} f(t), \quad u(t), k > 0. \quad (8.1.4.16)$$

Also the definition

$${}_0D_t^{-q(t)} f(t) \equiv \int_0^t \frac{(t-\tau)^{q(\tau)-1}}{\Gamma(q(\tau))} f(\tau) d\tau, \quad q(t) > 0, \quad (8.1.4.17)$$

can be shown to have the following weak form of composition, as

$${}_0D_t^{-k} {}_0D_t^{-v(t)} f(t) = {}_0D_t^{-(k+v(t))} f(t) \neq {}_0D_t^{-v(t)} {}_0D_t^{-k} f(t), \quad k, v(t) > 0. \quad (8.1.4.18)$$

The weak composition results indicated here have been validated by computer numerical simulation for a variety of functions.

The question of which is the most desirable definition for variable order integration, of course, is still an open issue. Based on the preliminary investigation of this study, the most compelling definition is given by

$$\boxed{{}_0D_t^{-q(t)} f(t) \equiv \int_0^t \frac{(t-\tau)^{q(t-\tau)-1}}{\Gamma(q(t-\tau))} f(\tau) d\tau, \quad q(t) > 0, \quad (8.1.4.19)}$$

because of adherence to the index law and because of the convolutional form which makes available all of the results of the associated theory. It may be possible that a slightly more complicated form of composition can be shown than that considered in the inequality (8.1.4.5).

Several candidate forms have been considered without success. It is noted that different physical processes may effectively use different definitions and that all three of the forms, equations (8.1.4.4), (8.1.4.15), and (8.1.4.17), may prove useful. Finally, it is further noted that a set of differintegrals parallel to those based on the Riemann-Liouville fractional integral (equation (8.1.3.1)) may be formed based on the Grünwald definition. A brief consideration of the variable structure differintegral based on the Grünwald definition is given in Appendix C.

8.1.5 Laplace Transform

The derivation of the Laplace transform of the variable structure integral follows that for the fixed order case exactly since the convolution theorem can be applied. Then, considering the uninitialized case

$$L\left\{{}_0D_t^{-q(t)} f(t)\right\} = \int_0^\infty e^{-st} \left(\int_0^t \frac{(t-\tau)^{q(t-\tau)-1}}{\Gamma(q(t-\tau))} f(\tau) d\tau \right) dt, \quad q(t) > 0, t > 0, \quad (8.1.5.1)$$

then as before

$$L\{h(t)*g(t)\} = H(s)G(s) = L\left\{\int_0^t h(\tau)g(t-\tau)d\tau\right\}. \quad (8.1.5.2)$$

Now taking $h(t) = f(t)$ and $g(t) = \frac{t^{q(t)-1}}{\Gamma(q(t))}$ the convolution theorem yields

$$L\left\{{}_0D_t^{-q(t)} f(t)\right\} = F(s)G(s) = L\{f(t)\}L\left\{\frac{t^{q(t)-1}}{\Gamma(q(t))}\right\}. \quad (8.1.5.3)$$

The variable structure differintegral allows the introduction of a new transfer function concept. The conventional transfer (see fig. 8-1-2) function relates the Laplace transform of the output to the transform of the input by

$$TF_1 \equiv \frac{L\{y(t)\}}{L\{f(t)\}} = \frac{L\left\{{}_0D_t^{-q(t)} f(t)\right\}}{L\{f(t)\}} \quad (8.1.5.4)$$

$$TF_1 = L\left\{\frac{t^{q(t)-1}}{\Gamma(q(t))}\right\}$$

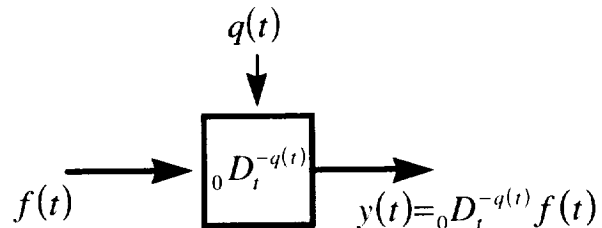

Figure 8-1-2.—Block diagram for transfer functions of variable structure integral.

Since q is now a variable it also may be thought of as an input, and a new transfer function may be defined as

$$TF_2 \equiv \frac{L\{y(t)\}}{L\{q(t)\}}. \quad (8.1.5.5)$$

For the considered definitions, the process from $q(t)$ to $y(t)$ has not been shown to be linear.

That is

$${}_0D_t^{-q_1(t)-q_2(t)} f(t) = {}_0D_t^{-q_1(t)} f(t) + {}_0D_t^{-q_2(t)} f(t)$$

has not been shown. Thus, the meaning and utility of equation (8.1.5.5), for these definitions requires further consideration.

The relationship of the two transfer functions may be determined as follows. Consider $f(t)$ and $q(t)$ to be related by $g(t)$, where

$$q(t) = \int_0^t f(\tau) g(t-\tau) d\tau \text{ then } L\{q(t)\} = L\{f(t)\}L\{g(t)\} \quad (8.1.5.6)$$

by the convolution theorem. Then

$$TF_2 = \frac{L\{y(t)\}}{L\{q(t)\}} = \frac{L\{f(t)\} TF_1}{L\{f(t)\} L\{g(t)\}} \Rightarrow \frac{TF_1}{TF_2} = L\{g(t)\}. \quad (8.1.5.7)$$

8.2 Variable Order Differentiation

If the form of equation (8.1.4.4) is assumed, then the parallel definition for the variable structure derivative might be given (considered) as

$${}_0D_t^{q(t)} f(t) \equiv {}_0D_t^m {}_0D_t^{-p(t)} f(t), \quad q(t) > 0, \quad (8.2.1)$$

where $q(t) = m - p(t)$, and m is a positive integer. If it is assumed that $q(t)$ is always positive, then m could be taken as the least integer greater than $q(t)$. However, since composition does not hold it is not at all clear that this is a reasonable definition. Matters are further complicated by the fact that it may be desirable to allow $q(t)$ to range over both positive and negative values. This places a “seam” at $q = 0$, which may make any approach based on the Riemann-Liouville definition implausible and perhaps require an approach based on the Grünwald definition. Consideration of the variable structure differintegral based on the Grünwald definition is presented in Appendix C.

9. Summary

The primary goal of the work discussed in this paper has been to make practical the application of the fractional calculus to the problems of science and engineering. This has required a new (modified) set of definitions for the fractional calculus. This formulation includes newly developed initialization functions that bring in the effects of the past for the system being analyzed. For fractional integrals and derivatives with respect to time, the initialization functions are time functions, which are a generalization of the initializing constants required for ordinary differential equations.

The following was accomplished:

- Presented several conceptualizations for the fractional differintegrals, both analytically based and physically based. Conceptualizations of the fractional differintegrals in terms of weighted time delays of the argument $f(t)$ (conveyor analogy) have been developed. Geometric interpretation of the generalized differintegral have been developed.
- Developed a formal initialization for the fractional integral and derivative which is incorporated directly into the definitions.
- Broadened the definition of the integer order derivative to include initialization.
- Proved that the Ross criteria for a fractional calculus, namely, that backward compatibility, zero order property, linearity, and composition hold under terminal charging conditions. Provided inter-relationship constraints between initialization functions required for satisfaction of the criteria under side charging conditions.
- Eliminated the requirement that the function and all of its derivatives be zero at the starting point, $t = c$, by the introduction of the initialization function.
- Developed Laplace transform expressions for the generalized fractional integrals and derivatives (with initialization included).
- Developed Laplace transforms for integer order and fractional order decompositions of both the generalized fractional integral and derivative.
- Determined the effect of the starting point on the Laplace transforms of the fractional integral and derivative.
- Determined the Laplace transform of the initialization function
- Generalized the Laplace transform of the differintegral (eq. (6.7.1)).
- Applied the above theoretical results to a wide variety of applications to demonstrate the power of the mathematics. Showed electrical computing elements that are theoretically capable of simulating the generalized (fractional) operators, and demonstrated some of the mathematical properties through use of these analog elements.

- Applied the theoretical results to solve applications, in instrumentation, electrochemistry, material creep, filtering, and viscoelastically damped vibration.
- Proposed a variable structure (order) fractional differintegral, provided motivation for its development, and proposed three particular Riemann-Liouville based implementations. Examined these for adherence to the criteria, and determined related Laplace transforms. Proposed Grünwald based variable structure definitions. (The variable structure concept appears to strengthen the connection between the fractional calculus and convolution theory.)

The issue of when to use d^v or d^m versus D^v or D^m , respectively, will be dictated by the application at hand and the nature of the required initialization (value of ψ). In an analytical setting it is the analyst's prerogative in relation to the task at hand.

While the above development was done with t , inferring time as the independent variable, the results may be readily extended to a spatial independent variable.

Appendix A

Application Of Dirichlet's Formula

This appendix augments the proof of criterion 5. It is basically a restatement of the work of Ross (1974a and 1974b). It is desired to validate

$$\begin{aligned}
 {}_c d_t^{-u-v} f(t) &= {}_c d_t^{-u} {}_c d_t^{-v} f(t) = \frac{1}{\Gamma(u)} \int_c^t (t-\tau)^{u-1} \frac{1}{\Gamma(v)} \int_c^\tau (\tau-\tau_1)^{v-1} f(\tau_1) d\tau_1 d\tau, \\
 &= \frac{1}{\Gamma(u)\Gamma(v)} \int_c^t \int_c^\tau (t-\tau)^{u-1} (\tau-\tau_1)^{v-1} f(\tau_1) d\tau_1 d\tau. \quad (A.1)
 \end{aligned}$$

Now by a special case of the Dirichlet formula applied over the triangular region shown in figure A-1, this equation can be written as

$$= \frac{1}{\Gamma(u)\Gamma(v)} \int_c^t \int_{\tau_1}^t (t-\tau)^{u-1} (\tau-\tau_1)^{v-1} f(\tau_1) d\tau d\tau_1, \quad (A.2)$$

or

$$= \frac{1}{\Gamma(u)\Gamma(v)} \int_c^t f(\tau_1) \int_{\tau_1}^t (t-\tau)^{u-1} (\tau-\tau_1)^{v-1} d\tau d\tau_1. \quad (A.3)$$

Now for the inner integral let

$$\begin{aligned}
 y = \frac{\tau - \tau_1}{t - \tau_1} &\Rightarrow \tau = (t - \tau_1)y + \tau_1 \\
 \text{and } d\tau &= (t - \tau_1)dy
 \end{aligned}$$

at the limits of integration

$$\tau = \tau_1 \Rightarrow y = 0 \quad \text{and} \quad \tau = t \Rightarrow y = 1.$$

Therefore the inner integral of equation (A.3) becomes

$$= \int_{\tau_1}^t (t-\tau)^{u-1} (\tau-\tau_1)^{v-1} d\tau = (t-\tau_1)^{u+v-1} \int_0^1 (1-y)^{u-1} y^{v-1} dy. \quad (A.4)$$

Now when $u > 0$ and $v > 0$ the integral is identified as the Beta integral with the value

$$\int_0^1 (1-y)^{u-1} y^{v-1} dy = \frac{\Gamma(u)\Gamma(v)}{\Gamma(u+v)}.$$

Thus, equation (A.3) becomes

$$= \frac{1}{\Gamma(u+v)} \int_c^t (t-\tau_1)^{u+v-1} f(\tau_1) d\tau_1, \quad (A.5)$$

which by definition is

$${}_c d_t^{-(u+v)} f(t).$$

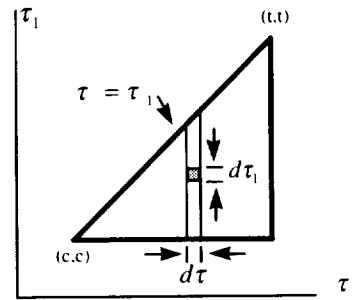

A 1-a

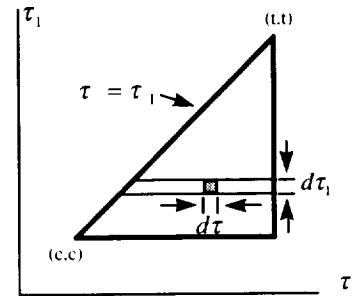

A 1-b

Figure A-1.—Reference triangle.

Appendix B

Laplace Transform Of Multiple Integer Order Integrals

This appendix will derive an expression for the Laplace transform of multiple integer order integrals for comparison with fractional transforms. Then, the problem is to determine

$$L\{g(t)\} = L\left\{\int_a^t \int_a^{t_1} \int_a^{t_2} \cdots \int_a^{t_{n-1}} f(t_n) dt_n dt_{n-1} \cdots dt_2 dt_1\right\}. \quad (\text{B.1})$$

For notational convenience let

$$g(t_j) = \int_a^{t_j} g(t_{j+1}) dt_{j+1}, \quad \text{for } j = 1, 2, \dots, n-2, \quad (\text{B.2})$$

and

$$g(t_{n-1}) = \int_a^{t_{n-1}} f(t_n) dt_n. \quad (\text{B.3})$$

Then starting from the outside,

$$L\{g(t)\} = L\left\{\int_a^t g(t_1) dt_1\right\} \quad (\text{B.4})$$

$$= \frac{1}{s} L\{g(t_1)\} + \frac{1}{s} \int_a^0 g(t_1) dt_1 = \frac{1}{s} L\{g(t_1)\} + \frac{c_1}{s}. \quad (\text{B.5})$$

Now replacing $g(t_1)$ using equation (B.2) yields

$$L\{g(t)\} = \frac{1}{s} \left[L\left\{\int_a^{t_1} g(t_2) dt_2\right\} \right] + \frac{c_1}{s}, \quad (\text{B.6})$$

$$= \frac{1}{s} \left[\frac{1}{s} L\{g(t_2)\} + \frac{c_2}{s} \right] + \frac{c_1}{s}, \quad (\text{B.7})$$

$$= \frac{1}{s^2} L\{g(t_2)\} + \frac{c_2}{s^2} + \frac{c_1}{s}. \quad (\text{B.8})$$

Repeating the process a total of n times yields the final result,

$$L\left\{\int_a^t \int_a^{t_1} \int_a^{t_2} \cdots \int_a^{t_{n-1}} f(t_n) dt_n dt_{n-1} \cdots dt_2 dt_1\right\} = \frac{1}{s^n} L\{f(t)\} + \sum_{i=1}^n \frac{c_i}{s^i} \quad n = 1, 2, 3, \dots, \quad (\text{B.9})$$

where the coefficients are given by

$$c_i = \int_a^0 g(t_i) dt_i. \quad (\text{B.10})$$

Appendix C

Variable Structure (Order) Differintegral Grünwald Basis

A variable structure differintegral may also be formulated based on the Grünwald definition, equation (4.2.1). Let $\Delta T = (t - a) / N$ in equation (4.2.1), and limit consideration to $q \Rightarrow q(t)$ or $q \Rightarrow q(t - j\Delta T)$. Then, expressing q generally as $q \Rightarrow q(t, j\Delta T)$, a generalized Grünwald form may be written as

$${}_a D_t^{q(t)} f(t) = \lim_{\substack{N \rightarrow \infty \\ \Delta T \rightarrow 0}} \sum_{j=0}^{N-1} \Delta T^{q_E(t, j\Delta T)} \frac{\Gamma(j - q_N(t, j\Delta T))}{\Gamma(-q_D(t, j\Delta T))\Gamma(j+1)} f(t - j\Delta T). \quad (C.1)$$

It is observed that $q(t, j\Delta T)$ occurs three times in this expression, in the exponent q_E , in the numerator q_N , and in the denominator q_D . Thus the number of permutations possible with this form is eight, which is comparable with the nine possible permutations using the Riemann-Liouville form for the differintegral. Table C-1 shows the possible permutations with the Grünwald formulation.

Table C-1 Permutations of q

| Permutation | 1 | 2 | 3 | 4 | 5 | 6 | 7 | 8 |
|-----------------------|-----|-----------------|-----------------|-----------------|-----------------|-----------------|-----------------|-----------------|
| $q_E(t, j\Delta T) =$ | t | t | t | t | $t - j\Delta T$ | $t - j\Delta T$ | $t - j\Delta T$ | $t - j\Delta T$ |
| $q_N(t, j\Delta T) =$ | t | t | $t - j\Delta T$ | $t - j\Delta T$ | $t - j\Delta T$ | $t - j\Delta T$ | t | t |
| $q_D(t, j\Delta T) =$ | t | $t - j\Delta T$ | t | $t - j\Delta T$ | $t - j\Delta T$ | t | $t - j\Delta T$ | t |

Consider two Grünwald based (eq. (C.1)) evaluations of ${}_a D_t^{q(t)} f(t)$, for a common $q(t)$, with one evaluation for $a < t \leq t_1$ and another for $a < t \leq t_2$ where $t_2 > t_1$. In particular, consider $q(t)$ as shown in figure C-1(a), where $q(t)$ steps from constant value $q(t_1)$ to the constant value $q(t_2)$ at time $t = t_1$. The evaluation to $t = t_2$ can be viewed as an evaluation from $t = a$ to t_1 , summed to an evaluation from $t = t_1$ to t_2 . In view of the hereditary nature of the fractional differintegral, the evaluation to $t = t_1$ is part of the history in the evaluation a to t_2 ; thus it is apparent that for the evaluation of ${}_a D_t^{q(t)} f(t) \Big|_{t=0}^{t=t_2}$ based on the value of $q(t, j\Delta T) = q(t)$ (i.e.,

all permutations except permutation 5, table C-1) will yield an undesirable result. This is so because, over the $t < t_1$ part of the evaluation the value of $q(t, j\Delta T) = q(t) = q(t_2)$ will be used in

the summation, essentially changing the history (figure C-1(b)). Thus it appears that the only (potentially) satisfactory permutation from this set of possibilities (table C-1) is permutation 5, namely,

$${}_a D_t^{q(t)} f(t) = \lim_{\substack{N \rightarrow \infty \\ \Delta T \rightarrow 0}} \sum_{j=0}^{N-1} \Delta T^{q(t-j\Delta T)} \frac{\Gamma(j - q_N(t - j\Delta T))}{\Gamma(-q_D(t - j\Delta T))\Gamma(j+1)} f(t - j\Delta T). \quad (C.2)$$

This definition parallels equation (8.1.4.4), and adds to the credibility of the convolution related variable structure form.

The intuitive nature of the Grünwald form, in terms of the available conceptualizations allows the hope that a form of it may be evolved which would satisfy composition. Detailed studies of the Grünwald permutations have not yet been performed.

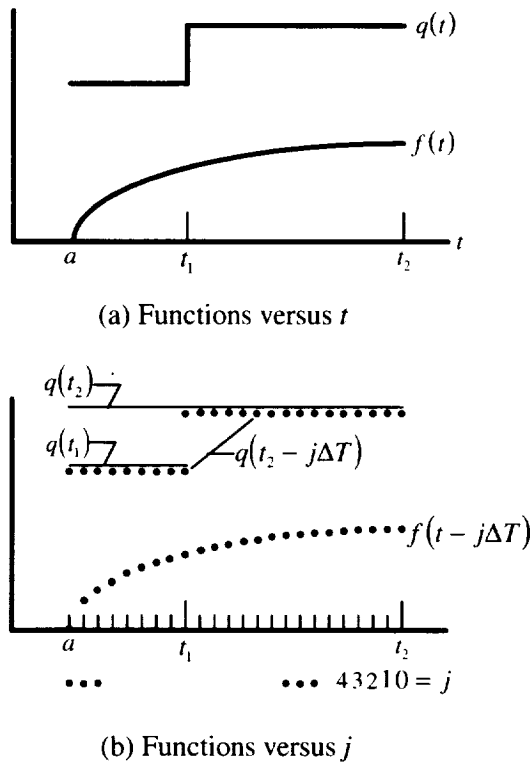

Figure C-1.—Variable q differintegration. (a) Functions versus t . (b) Functions versus j .

References

- Apostol, T.M.: *Mathematical Analysis: A Modern Approach to Advanced Calculus*. Addison-Wesley Publishing Co., 1957. Library of Congress Card Number 57-8707.
- Bagley, R.L.: The Thermorheologically Complex Material. *Int. J. Engng. Sci.*, vol. 29, no. 7, 1991, pp. 797-806.
- Bard, A.J.; and Faulkner, L.R.: *Electrochemical Methods*. John Wiley and Sons, New York, NY, 1980. ISBN 0-47-05542-5.
- Bland, D.R.: *The Theory of Linear Viscoelasticity*. Pergamon Press, Oxford, England, 1960. LCCCN-59-14489.
- Churchill, R.V.: *Operational Mathematics*. Second ed., McGraw Hill, New York, NY, 1958. Library of Congress Card Number 58-6678.
- Davis, H.T.: *The Theory of Linear Operators: From the Standpoint of Differential Equations of Infinite Order*. The Principia Press, Bloomington, IN, 1936.
- Gabel, R.A.; and Roberts, R.A.: *Signals and Linear Systems*. John Wiley and Sons, New York, NY, 1973. ISBN 0-471-28900-0.
- Hartley, T.T.; and Lorenzo, C.F.: *Insights into the Initialization of Fractional Order Operators Via Semi-Infinite Lines*. NASA TM-208407, 1998.
- Hartley, T.T.; Lorenzo, C.F.; and Qammer, H.K.: Chaos in a Fractional Order Chua's System. *IEEE Trans. Circuits Sys. I: Fundamental Theory and Applications*, vol. 42, no. 8, Aug. 1995, pp. 485-490.
- Kalia, R.N., ed.: *Recent Advances in Fractional Calculus (Global Research Notes Series in Mathematics)*. Global Publishing Co., Sauk Rapids, MN, 1993. ISBN 0-9638155-0-4.
- Kiryakova, V.S.: *Generalized Fractional Calculus and Applications (Pittman Research Notes in Mathematics Series, 301)*. Longman Scientific and Technical, Essex, England and John Wiley and Sons, New York, NY, 1994. ISBN 0-582-219779, ISSN 0269-3674.
- McBride, A.C.: *Fractional Calculus and Integral Transforms of Generalized Functions*. Pitman Advanced Publishing, San Francisco, CA, 1979.
- McBride, A.C.; and Roach, G.F.: *Fractional Calculus*. Pittman Publishing Limited (Research Notes in Mathematics Series, 138). Longman Scientific and Technical, Essex, England and John Wiley and Sons, New York, NY, 1985. ISBN 0-273-08753-3.
- Mikusinski, J.: *Operational Calculus*. Pergamon Press, New York, NY, 1959.
- Miller, K.S.; and Ross, B.: *An Introduction to the Fractional Calculus and Fractional Differential Equations*. John Wiley and Sons, New York, NY, 1993. ISBN 0-471-58884-9.

Nishimoto, K.: An Essence of Nishimoto's Fractional Calculus—Integrations and Differentiations of Arbitrary Order. Descartes Press Co., Koriyama, Japan, 1991.

Oldham, K.B.; and Spanier, J.: The Fractional Calculus—Theory and Applications of Differentiation and Integration to Arbitrary Order. Vol. 111 Mathematics in Science and Engineering, Academic Press, Inc., New York, NY, 1974. ISBN 0-12-525550-0.

Ross, B.: The Development, Theory, and Applications of the Gamma-Function and a Profile of Fractional Calculus. Ph.D. Thesis, New York Univ., 1974, S94-10032.

Ross, B.: A Brief History and Exposition of the Fundamental Theory of Fractional Calculus. Lecture Notes in Mathematics, vol. 457, ed., Dold, A. and Eckmann, B.: Fractional Calculus and Its Applications. Proceedings of the International Conference Held at the University of New Haven, June 1974b, ed. Ross, B. Springer-Verlag, Berlin, 1974, ISBN 3-540-07161-X, ISBN 387-07161-X.

Samko, S.G.; Kilbas, A.A.; and Marichev, O.I.: Fractional Integrals and Derivatives—Theory and Applications. Gordon and Breach Science Publishers, Philadelphia, PA, 1993. ISBN 2-88124-864-0.

Smit, W.; and deVries, H.: Rheological Models Containing Fractional Derivatives. Rheol. Acta, vol. 9, no. 4, 1970, pp. 525-534.

Spanier, J.; and Oldham, K.B.: An Atlas of Functions. Hemisphere Publishing Corp., Washington, DC, 1987. ISBN 0-89116-573-8.

Wylie, C.R.: Advanced Engineering Mathematics. Fourth ed., McGraw Hill, New York, NY, 1975. ISBN 0-07-072180-7.

Application References

Acoustics, Boundary Layer, and Turbulence

- Keller, J.J.: Propagation of Simple Non-Linear Waves in Gas Filled Tubes With Friction, *Journal of Applied Mathematics and Physics (ZAMP)*, vol. 32, Mar. 1981, pp. 170–181.
- Ruelle, D.; and Takens F.: On the Nature of Turbulence. *Comm. Math. Phys.*, vol. 20, no. 3, 1971, pp. 167–192.
- Sugimoto, N.: ‘Generalized’ Burgers Equations and Fractional Calculus. *Nonlinear Wave Motion*. Longman Scientific and Technical, Harlow, England, 1989, pp. 162–179.
- Sugimoto, N.: Evolution of Nonlinear Acoustic Waves in a Gas-filled Pipe. *Frontiers of Nonlinear Acoustics: Proceedings of 12th ISNA*, ed., Hamilton, M.F. and Blackstock. Elsevier Science Publishers Ltd., London, England, 1990.
- Sugimoto, N.: Burgers Equation With a Fractional Derivative: Hereditary Effects on Nonlinear Acoustic Waves. *J. Fluid Mech.*, vol. 225, 1991, pp. 631–653.

Controls and Dynamics

- Axtell, M.; and Bise, M.E.: Fractional Calculus Applications in Control Systems. *Proceedings of the IEEE National Aerospace and Electronics Conference*, 1990, pp. 563–566.
- Bagley, R.L.: “The Initial Value Problem for Ordinary Differential Equations with Constant Coefficients”, Air Force Institute of Technology, AD–203 843, N89–20764, AFIT–TR–EN 88–1, September 1988.
- Bagley, R.L. and Calico, R.A.: “Fractional Order State Equations for the Control of Viscoelastically Damped Structures”, *Journal of Guidance, Control, and Dynamics*, Vol. 14, No. 2, pp. 304–311, Mar.-Apr. 1991.
- Mbodje, B.; and Montseny, G.: Boundary Fractional Derivative Control of the Wave Equation. *IEEE Trans. Automat. Cont.*, vol. 40, no. 2, Feb. 1995.
- Skaar, S.B.; Michel, A.N.; and Miller, R.K.: Stability of Viscoelastic Control Systems. *IEEE Trans. Automat. Cont.*, vol. 33, no. 4, Apr. 1988.

Diffusion

- Metzler, R.; Glöckle, W.G.; and Nonnenmacher, T.F.: Fractional Model Equation for Anomalous Diffusion. *Physica A*, vol. 211, no. 1, 1994, pp.13–24.
- Scher, H.; and Montroll, E.W.: Anomalous Transit-Time Dispersion in Amorphous Solids. *Physics Rev. B*, vol. 12, no. 6, Sept. 1975, pp. 2455–2477.

Schnieder, W.R.; and Wyss, W.: Fractional Diffusion and Wave Equations. *J. Math. Phys.*, vol. 30, no. 1, Jan. 1989, pp. 134–144.

Wyss, W.: The Fractional Diffusion Equation. *J. Math. Phys.*, vol. 27, no. 11, Nov. 1986.

$1/f^\beta$ Electrical Circuit Noise

Bittel, H.: Noise in Magnetic and Dielectric Materials. *Physica B & C*, vol. 83B & C, 1976, pp. 6–13.

Hooge, F.N.: Discussion of Recent Experiments on $1/f$ Noise. *Physica*, vol. 60, no. 1, 1972, pp. 130–144.

Hooge, F.N.: $1/f$ Noise. *Physica B & C*, vol. 83B & C, May 1976, pp. 14–23.

Keshner, M.S.: $1/f$ Noise. *Proc. IEEE*, vol. 70, no. 3, Mar. 1982, pp. 212–218.

Electrical and Electrochemistry

Bard, A.J.; and Faulkner, L.R.: *Electrochemical Methods: Fundamentals and Applications*. John Wiley and Sons, New York, NY, 1980. ISBN 0–471–05542–5.

Halijak, C.A.: An RC Impedance Approximant to $(1/s)^{1/2}$. *Correspondence, IEEE Trans. Circuit Theory*, Dec. 1964, pp. 494–495.

Ichise, M.; Nagayanagi, Y.; and Kojima, T.: An Analog Simulation of Non-Integer Order Transfer Functions for Analysis of Electrode Processes. *J. Electroanal. Chem. Interfacial Electrochem.*, vol. 33, no. 2, Dec. 1971, pp. 253–265.

Kanoh, H.; Feng, Q.; Hirotsu, T.; and Ooi, K.: A.C. Impedance Analysis for Li^+ Insertion of a $\text{Pt}/\lambda\text{-MnO}_2$ Electrode in an Aqueous Phase. *J. Electrochem. Soc.*, vol. 143, no. 8, Aug. 1996, pp. 2610–2615.

Oldham, K.B.: Semi-integral Electroanalysis: Analog Implementation. *Analytical Chemistry*, vol. 45, no. 1, Jan. 1973, pp. 39–47.

Sandi, G.; Winans, R.E.; and Carrado, K.A.: New Carbon Electrodes for Secondary Lithium Batteries. *J. Electrochem. Soc.*, vol. 143, no. 5, May, 1996, pp. 195–198.

Yu, Q.; and Wing, O.: Computational Models of Transmission Lines With Skin Effects and Dielectric Loss. *IEEE Trans. Circuits Sys.-1: Fundamental Theory and Applications*, vol. 41, no. 2, Feb. 1994, pp. 107–119.