



HAL
open science

Input-to-state stabilizing event-triggered control for linear systems with output quantization

M. Abdelrahim, V.S. Dolk, W.P.M.H. Heemels

► **To cite this version:**

M. Abdelrahim, V.S. Dolk, W.P.M.H. Heemels. Input-to-state stabilizing event-triggered control for linear systems with output quantization. the 55th IEEE Conference on Decision and Control, Dec 2016, Las Vegas, United States. pp.483 - 488, 10.1109/CDC.2016.7798315 . hal-01445745

HAL Id: hal-01445745

<https://hal.archives-ouvertes.fr/hal-01445745>

Submitted on 25 Jan 2017

HAL is a multi-disciplinary open access archive for the deposit and dissemination of scientific research documents, whether they are published or not. The documents may come from teaching and research institutions in France or abroad, or from public or private research centers.

L'archive ouverte pluridisciplinaire **HAL**, est destinée au dépôt et à la diffusion de documents scientifiques de niveau recherche, publiés ou non, émanant des établissements d'enseignement et de recherche français ou étrangers, des laboratoires publics ou privés.

Input-to-state stabilizing event-triggered control for linear systems with output quantization

M. Abdelrahim, V.S. Dolk and W.P.M.H. Heemels

Abstract— In this paper, we are interested in the stabilization of a linear plant based on output measurements that are subject to dynamic quantization. Moreover, to save communication resources, these measurements are transmitted to the controller using an output-based event-triggering condition. The proposed event-triggering mechanism and the dynamic quantization strategy ensure an input-to-state stability (ISS) property of a set around the origin with respect to the external disturbances. The existence of a strictly positive lower bound is ensured on both the inter-transmission times and the inter-zoom times in order to prevent the occurrence of Zeno behaviour. The chattering between zoom-in and zoom-out actions is avoided, and the zoom variable of the dynamic quantizer is guaranteed to be bounded. We characterize the inherent tradeoff between transmissions and quantization in terms of design parameters that can be tuned by the user. The effectiveness of the approach is illustrated on a numerical example.

I. INTRODUCTION

Networked control systems (NCS) are systems in which the feedback information and/or the control input are transmitted over a network. The communication channel can be possibly shared with other users/devices while the resources of the network are often limited. Hence, the network should be used efficiently. In this regard, event-triggered controllers have shown more potential to achieve this goal than time-triggered setups. The idea of this technique is to allow the network access only when it is needed, from the stability/performance perspectives, see, e.g., [9] and the references therein. This consequently allows to save the network from unnecessary usages, however, more difficulties are induced on the stability analysis. In particular, when the plant is subject to external disturbances, the event-triggered controller has to achieve:

- (i) an input-to-state stability property of a set around origin with respect to the external disturbances;
- (ii) the existence of a strictly positive lower bound on the inter-event times in order to exclude the presence of Zeno behavior.

The latter objective is particularly challenging when the system is affected by exogenous inputs [2] and/or when

Mahmoud Abdelrahim, Victor Dolk and Maurice Heemels are with the Control Systems Technology Group, Department of Mechanical Engineering, Eindhoven University of Technology, the Netherlands {m.m.o.abdelrahim, v.s.dolk, m.heemels}@tue.nl.

This work was supported by the Innovational Research Incentives Scheme under the VICI grant “Wireless control systems: A new frontier in automation” (No. 11382), and the STW project “Integrated design approach for safety-critical real-time automotive systems” (No. 12698) awarded by NWO (The Netherlands Organisation for Scientific Research) and STW (Dutch Technology Foundation).

only an output of the plant is measured [6]. In addition, the quantization phenomenon is unavoidable in NCS due to the digital nature of the communication channel and the fact that only a finite amount of data can be transmitted over the network. In this context, the dynamic quantization devices are of particular interest since the quantizer saturation can be avoided with finite quantization range, which may not be possible to achieve using static quantizers, see, e.g., [10], [11], [14] and the references therein. In dynamic quantization devices, the quantizer uses a zoom variable to increase the quantizer range when a saturation is detected (referred to as zoom-out stage) or to decrease the quantizer range to extract more precise information (referred to as zoom-in stage). Although the idea of dynamic quantization is appealing, more challenges are produced:

- (iii) since the zoom actions are state-dependent, the accumulation of zoom instants need to be prevented;
- (iv) chattering between the zoom-in and the zoom-out actions should be avoided;
- (v) the zoom variable has to remain bounded.

These issues are non-trivial to handle when the plant is affected by unknown exogenous inputs and/or when the response of the closed-loop system exhibits oscillations [12], [17].

In this paper, we consider the scenario where the plant dynamics is affected by unknown external disturbances and the output measurement is quantized by means of dynamic quantizers. The quantized feedback information is transmitted to the controller by using a dynamic output-based event-triggering condition in the sense of [5], [7], [16]. The triggering mechanism enforces the existence of a strictly positive lower bound on the inter-transmission times, which excludes Zeno behaviour for the transmission instants. To achieve a similar property for the zoom instants, the quantizer only updates the zoom variable at transmission instants. Indeed, the quantizer update is performed before the feedback information is being transmitted to the controller, which ensures that the broadcasted message to the controller is correct. It is important to mention that when both transmissions and quantization are considered in NCS, more attention should be paid since the network may be redundantly used at certain transmission instants. This issue follows from the fact the quantizer has only a finite number of quantization levels. To save the network from redundant accesses, we need to ensure that:

- (vi) at each transmission instant, the broadcasted quantized

measurement is not exactly the same as the most recent value received by the controller.

Although the synthesis of the combined event-triggered controllers and dynamic quantizers is relevant in practice, few results in the literature have addressed this problem. In this context, we are only aware of [13], [18], [19]. The techniques of [13], [18] are dedicated to event-triggered *state feedback* controllers and the authors of [18] only focus on the zoom-in stage while the authors of [13] assume that the plant dynamics is not affected by external disturbances. The developed approach in [19] does not take into account the effect of exogenous inputs on the control system or the practical aspects that we consider in (i)-(vi). To the best of our knowledge, this is the first work on the design of input-to-state stabilizing event-triggered controllers with dynamic quantization of the *output feedback* information that deals with all the previously mentioned issues in (i)-(vi).

The design strategy reveals a tradeoff between the amount of transmissions and the precision of the quantized information. The effectiveness of the approach is illustrated on a numerical example.

II. PRELIMINARIES

Let $\mathbb{R} := (-\infty, \infty)$, $\mathbb{R}_{\geq 0} := [0, \infty)$, $\mathbb{N} := \{0, 1, 2, \dots\}$ and $\mathbb{N}_{\geq 1} := \{1, 2, \dots\}$. A continuous function $\gamma : \mathbb{R}_{\geq 0} \rightarrow \mathbb{R}_{\geq 0}$ is of class \mathcal{K} if it is zero at zero and strictly increasing. It is of class \mathcal{K}_∞ if, in addition, $\gamma(s) \rightarrow \infty$ as $s \rightarrow \infty$. A continuous function $\gamma : \mathbb{R}_{\geq 0}^2 \rightarrow \mathbb{R}_{\geq 0}$ is of class \mathcal{KL} if for each fixed $t \in \mathbb{R}_{\geq 0}$, $\gamma(\cdot, t)$ is of class \mathcal{K} , and $\gamma(s, \cdot)$ is nonincreasing and satisfies, for each fixed $s \in \mathbb{R}_{\geq 0}$, $\lim_{t \rightarrow \infty} \gamma(s, t) = 0$. We denote the minimum and maximum eigenvalues of the real symmetric matrix A as $\lambda_{\min}(A)$ and $\lambda_{\max}(A)$, respectively. We write A^T to denote the transpose of A , and \mathbb{I}_n stands for the identity matrix of dimension n . The symbol \star stands for symmetric blocks. We write $(x, y) \in \mathbb{R}^{n_x+n_y}$ to represent the vector $[x^T, y^T]^T$ for $x \in \mathbb{R}^{n_x}$ and $y \in \mathbb{R}^{n_y}$. For a vector $x \in \mathbb{R}^{n_x}$, we denote by $|x| := \sqrt{x^T x}$ its Euclidean norm and, for a matrix $A \in \mathbb{R}^{n \times m}$, $|A| := \sqrt{\lambda_{\max}(A^T A)}$. Given a set $\mathcal{A} \subset \mathbb{R}^n$ and a vector $x \in \mathbb{R}^n$, the distance of x to \mathcal{A} is defined as $|x|_{\mathcal{A}} := \inf_{y \in \mathcal{A}} |x - y|$. We use the following *ceiling* function: $\lceil x \rceil := \min\{k \in \mathbb{N} : k \geq x\}$.

We consider hybrid systems of the following form [3], [8]

$$\dot{x} = F(x, w) \quad x \in \mathcal{C}, \quad x^+ \in G(x) \quad x \in \mathcal{D}, \quad (1)$$

where $x \in \mathbb{R}^{n_x}$ is the state, $w \in \mathbb{R}^{n_w}$ is an exogenous input, \mathcal{C} is the flow set, F is the flow map, \mathcal{D} is the jump set and G is the jump map. Solutions to system (1) are defined on *hybrid time domains*. We call a subset $E \subset \mathbb{R}_{\geq 0} \times \mathbb{N}$ a *compact hybrid time domain* if $E = \bigcup_{j=0}^{J-1} ([t_j, t_{j+1}], j)$ for some finite sequence of times $0 = t_0 \leq t_1 \leq \dots \leq t_J$ and it is a *hybrid time domain* if for all $(T, J) \in E$, $E \cap ([0, T] \times \{0, 1, \dots, J\})$ is a compact hybrid time domain. A *hybrid signal* is a function defined on a hybrid time domain. For more details on properties of solutions to hybrid system (1), we refer the reader to [3], [8].

We use the following definition of \mathcal{L}_∞ -norm for hybrid signals [3], [15].

Definition 1. For a hybrid signal w , with domain $\text{dom } w \in \mathbb{R}_{\geq 0} \times \mathbb{N}$, and a scalar $T \in \mathbb{R}_{\geq 0}$, the T -truncated \mathcal{L}_∞ norm is given by

$$\|w_{[T]}\|_\infty := \max \left\{ \begin{array}{l} \text{ess sup}_{(t,j) \in \text{dom } w \setminus \Gamma(w), t+j \leq T} |w(t, j)|, \\ \sup_{(t,j) \in \Gamma(w), t+j \leq T} |w(t, j)| \end{array} \right\}, \quad (2)$$

where $\Gamma(w)$ denotes the set of all (t, j) such that $(t, j) \in \text{dom } w$ and $(t, j+1) \in \text{dom } w$. The \mathcal{L}_∞ norm of w is given by $\|w\|_\infty := \lim_{T \rightarrow T^*} \|w_{[T]}\|_\infty$, where $T^* := \sup\{t + j : (t, j) \in \text{dom } w\}$. Moreover, we say that $w \in \mathcal{L}_\infty$ whenever the above limit exists and is finite. \square

We adopt the following ISS notion for hybrid systems [3].

Definition 2. Consider the hybrid system (1) and a set $\mathcal{A} \subset \mathbb{R}^{n_x}$. The set \mathcal{A} is *input-to-state stable (ISS)* w.r.t. w if there exist $\beta \in \mathcal{KL}$ and $\psi \in \mathcal{K}$ such that, for each $x(0, 0) \in \mathcal{X} \subset \mathbb{R}^{n_x}$ and $w \in \mathcal{L}_\infty$, each maximal solution pair (x, w) is complete and satisfies for all $(t, j) \in \text{dom } x$

$$|x(t, j)|_{\mathcal{A}} \leq \max\{\beta(|x(0, 0)|_{\mathcal{A}}, t + j), \psi(\|w\|_\infty)\}. \quad (3)$$

\square

III. PROBLEM FORMULATION

Consider the LTI plant model

$$\dot{x}_p = A_p x_p + B_p u + E_p w, \quad y = C_p x_p, \quad (4)$$

where $x_p \in \mathbb{R}^{n_p}$ is the plant state, $u \in \mathbb{R}^{n_u}$ is the control input, $w \in \mathbb{R}^{n_w}$ is an unknown plant disturbance, $y \in \mathbb{R}^{n_y}$ is the measured output, and A_p, B_p, C_p, E_p are matrices of appropriate dimensions. The disturbance w is assumed to be Lebesgue measurable and locally bounded. We design the dynamic controller

$$\dot{x}_c = A_c x_c + B_c \hat{y}_q, \quad u = C_c x_c + D_c \hat{y}_q \quad (5)$$

where $x_c \in \mathbb{R}^{n_c}$ is the controller state, $\hat{y}_q \in \mathbb{R}^{n_y}$ denotes the last transmitted and quantized value of y , and A_c, B_c, C_c, D_c are matrices of appropriate dimensions. The controller (5) is designed by an emulation approach in the sense that we assume that the closed-loop system given by (4) and (5) is stable when the effects of both the quantization and the network are absent, i.e. when $\hat{y}_q = y$.

A. Setup description

We consider the scenario where the controller is directly connected to the plant while the output measurement y is transmitted to the controller over a digital communication channel at discrete time instants $t_k, k \in \mathbb{N}$. Due to the digital nature of the network, the value of y is subject to quantization before being transmitted to the controller. Hence, at $t_k, k \in \mathbb{N}$, the current value of y is quantized, encoded and the resulting encrypted data is sent over the channel. The decoder on the other side of the network reconstruct the received encrypted message and delivers the

quantized feedback information to the controller, which uses value to update \hat{y}_q in the control law (5), see Figure 1. The value of \hat{y}_q is kept constant between two consecutive transmission instants by means of zero-order-hold (ZOH).

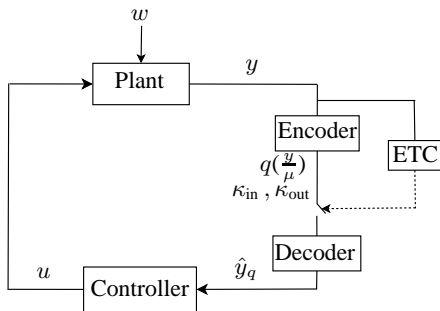

Fig. 1. Quantized networked control system

B. Event-triggering mechanism

The sequence of transmission instants $t_k, k \in \mathbb{N}$ is produced by an event-triggering mechanism based on the past (true) values of the output measurement y and the last broadcasted (quantized) value \hat{y}_q . The triggering mechanism is dynamic in the sense of [5], [7], [16] and takes the following form

$$t_{k+1} = \inf\{t > t_k + T \mid \eta(t) \leq 0\}, \quad (6)$$

where $t_0 = 0, T > 0, \eta \in \mathbb{R}_{\geq 0}$. The constant time $T > 0$ is a strictly positive lower bound on the inter-transmission times of the output y that we enforce to prevent the occurrence of Zeno. The variable η is the solution to the dynamical system

$$\dot{\eta} = \Psi(o) \quad t \in (t_k, t_{k+1}), \quad \eta(t_k^+) = \eta_0(o) \quad (7)$$

for some functions Ψ and η_0 , which are specified in Section V and $o \in \mathbb{R}^{n_o}$ represents locally available information at the event-triggering mechanism.

C. Dynamic quantization

At each transmission instant $t_k, k \in \mathbb{N}$, the current output measurement y is quantized before being broadcasted over the network by means of dynamic quantizers. In other words, a dynamic variable $\mu \in \mathbb{R}_{\geq 0}$ (referred to as the zoom variable) is used to adjust the initial quantizer range $M > 0$ and the initial quantizer resolution $\Delta > 0$ based on the magnitude of the output measurement y . Hence, the dynamic range and the dynamic resolution of the quantizer are given by $M\mu$ and $\Delta\mu$, respectively. This leads to the quantizer function q_μ , which is defined as $q_\mu(y) := \mu q\left(\frac{y}{\mu}\right)$, where $q: \mathbb{R}^{n_y} \rightarrow Q \subseteq \mathbb{R}^{n_y}$ is a piecewise constant function with Q a finite subset of \mathbb{R}^{n_y} . We assume that the function q satisfies the following assumption, see also [10], [12], [14].

Assumption 1. For all $y \in \mathbb{R}^{n_y}$ it holds that

$$|y| \leq M \quad \Rightarrow \quad |q(y) - y| \leq \Delta. \quad (8)$$

This assumption means that the magnitude of the quantization error $|q(y) - y|$ is upper bounded by Δ as long as the

quantizer is not saturated. The quantization overall device consists of two units being an encoder at the sensor side and a decoder at the controller side. The encoder adapts the zoom variable μ at transmission instants $t_k, k \in \mathbb{N}$ according to the magnitude of the output measurements y as follows

$$\mu(t_k^+) := \begin{cases} \Omega_{\text{in}}^{\kappa_{\text{in}}(y, \mu)} \mu(t_k) & \max\{|y(t_k)|, \Delta_0\} \leq \ell_{\text{in}} \mu(t_k) \\ \Omega_{\text{out}}^{\kappa_{\text{out}}(y, \mu)} \mu(t_k) & |y(t_k)| \geq \ell_{\text{out}} \mu(t_k), \end{cases} \quad (9)$$

where $\Omega_{\text{in}}^{\kappa_{\text{in}}(y, \mu)}, \Omega_{\text{out}}^{\kappa_{\text{out}}(y, \mu)} > 0$ are the zoom-in and zoom-out factors, respectively, at each update instant t_k with $\Omega_{\text{in}} \in (0, 1), \Omega_{\text{out}} > 1$ and functions $\kappa_{\text{in}}, \kappa_{\text{out}}: \mathbb{R}^{n_y} \times \mathbb{R} \rightarrow \mathbb{N}$ are to be designed. The parameters $0 < \ell_{\text{in}} < \ell_{\text{out}} < M$ are used to define the zoom-in surface and the zoom-out surface, respectively. The constant $\Delta_0 > 0$ can be arbitrarily chosen, typically small.

When the magnitude of the plant output $|y|$ is near the quantizer range $M\mu$, (determined by the zoom-out surface $\ell_{\text{out}} \mu$) we multiply μ by a zoom-out factor $\Omega_{\text{out}}^{\kappa_{\text{out}}(y, \mu)} > 1$, i.e. μ is increased, such that saturation is avoided to maintain the property $|y| \leq M\mu$. This action is known as the ‘‘zoom-out’’ stage. On the other hand, when $|y|$ becomes relatively small compared to the quantizer range $M\mu$ (determined by the zoom-in surface $\ell_{\text{in}} \mu$), we decrease the range by multiplying μ by a zoom-in factor $\Omega_{\text{in}}^{\kappa_{\text{in}}(y, \mu)} \in (0, 1)$ such that more precise information can be transmitted. This action is known as the ‘‘zoom-in’’ stage, see, e.g., [12] for more details. Observe that if $\mu < \frac{\Delta_0}{\ell_{\text{in}}}$, no zoom-in event occurs. Essentially, we stop zooming-in when the value of y is known sufficiently accurate and is very close to zero. This property ensures that the value of $\Omega_{\text{in}}^{\kappa_{\text{in}}(y, \mu)}$ is finite (especially when y crosses zero).

Observe that the zoom variable μ in (9) is only updated at transmission instants $t_k, k \in \mathbb{N}$ and if the zoom-in or the zoom-out condition is met. Consequently, the inter-zoom times are lower bounded by the minimum inter-transmission time T ensured by the event-triggering condition (6). Between two consecutive zoom actions, the variable μ is held constant, i.e. $\dot{\mu} = 0$ during the inter-zoom times. To decode the transmitted information in a successful manner, the zoom factors $\Omega_{\text{in}}^{\kappa_{\text{in}}(y, \mu)}, \Omega_{\text{out}}^{\kappa_{\text{out}}(y, \mu)}$ are also sent at each transmission instant $t_k, k \in \mathbb{N}$, see Figure 1. We assume that the zoom variables of both the encoder and the decoder are initialized at the same value, see Remark 1 in [10] for an in-depth discussion on this point.

D. Problem statement

Our objective is to design both the event-triggering condition, i.e. to define the time T and the functions Ψ and η_0 in (6)-(7), and the dynamic quantization strategy, i.e. to define the parameters $\Delta_0, \ell_{\text{in}}, \ell_{\text{out}}$ and the functions $\kappa_{\text{in}}, \kappa_{\text{out}}$ in (9), such that objectives (i)-(vi) mentioned in Section I are satisfied for the resulting closed-loop system.

IV. HYBRID MODEL

In this section, we explain how to formulate the closed-loop system as a hybrid dynamical model [8]. We define the

sampling-induced error as $e_s := \hat{y}_q - q_\mu(y)$, which is reset to zero at each transmission instant $t_k, k \in \mathbb{N}$. We also define the quantization error as $e_q := q_\mu(y) - y$. Hence, the total (true) error is given by

$$e := e_s + e_q = \hat{y}_q - y. \quad (10)$$

Between two transmission instants, due to the ZOH, the dynamics of e is $\dot{e} = -\dot{y} = -C_p \dot{x}_p$, and at each transmission instant, we have that $e^+ = e_q$ since $\hat{y}_q^+ = q_\mu(y)$. We note that e is not necessarily reset to 0 at $t_k, k \in \mathbb{N}$ due to the effect of quantization. This phenomenon induces nontrivial difficulties and requires careful handling since it may have a negative impact on the closed-loop stability. Let $x = (x_p, x_c) \in \mathbb{R}^{n_x}$. Then, in view of (4), (5), (10), the flow dynamics of x and e are given by $\dot{x} = \mathcal{A}_1 x + \mathcal{B}_1 e + \mathcal{E}_1 w$ and $\dot{e} = \mathcal{A}_2 x + \mathcal{B}_2 e + \mathcal{E}_2 w$, where $\mathcal{A}_1 := \begin{bmatrix} A_p + B_p D_c C_p & B_p C_c \\ B_c C_p & A_c \end{bmatrix}$, $\mathcal{B}_1 := \begin{bmatrix} B_p D_c \\ B_c \end{bmatrix}$, $\mathcal{E}_1 := \begin{bmatrix} E_p \\ 0 \end{bmatrix}$, $\mathcal{A}_2 := [-C_p(A_p + B_p D_c C_p) \quad -C_p B_p C_c]$, $\mathcal{B}_2 := -C_p B_p D_c$, and $\mathcal{E}_2 := -C_p E_p$.

We introduce an auxiliary variable $\tau \in \mathbb{R}_{\geq 0}$ to describe the time elapsed since the last transmission instant, which has the dynamics for $k \in \mathbb{N}$, $\dot{\tau} = 1$ for $t \in (t_k, t_{k+1})$ and $\tau(t_k^+) = 0$. We also use a boolean variable $p \in \{0, 1\}$ to order the sequence of jump events in the sense that the zoom variable μ is updated before y is transmitted, when a zoom-in/zoom-out is required at any transmission instant t_k . Let $\xi := (x, e, \mu, \tau, \eta, p) \in \mathbb{X}$ be the concatenation of the state variables, with $\mathbb{X} = \mathbb{R}^{n_x} \times \mathbb{R}^{n_y} \times \mathbb{R}_{\geq 0} \times \mathbb{R}_{\geq 0} \times \mathbb{R}_{\geq 0} \times \{0, 1\}$. In view of (6) and (7), the flow set \mathcal{C} and the jump set \mathcal{D} are given by

$$\begin{aligned} \mathcal{C} &:= \left\{ \xi \in \mathbb{X} : (\tau \in [0, T] \text{ or } \eta \geq 0) \text{ and } p = 0 \right\} \\ \mathcal{D} &:= \left\{ \xi \in \mathbb{X} : (\tau \geq T \text{ and } \eta \leq 0) \text{ or } p = 1 \right\}. \end{aligned} \quad (11)$$

Then, we obtain the hybrid system

$$\begin{aligned} \dot{\xi} &= \begin{pmatrix} \mathcal{A}_1 x + \mathcal{B}_1 e + \mathcal{E}_1 w \\ \mathcal{A}_2 x + \mathcal{B}_2 e + \mathcal{E}_2 w \\ 0 \\ 1 \\ \Psi(o) \\ 0 \end{pmatrix} & \xi \in \mathcal{C} \\ \xi^+ &\in \begin{cases} \left\{ G_\mu(\xi) \right\}, & \text{for } \xi \in \mathcal{D} \wedge p = 0 \\ \left\{ G_y(\xi) \right\}, & \text{for } \xi \in \mathcal{D} \wedge p = 1 \end{cases} & \xi \in \mathcal{D}, \end{aligned} \quad (12)$$

where $G_\mu(\xi) := (x, e, \Omega_{\text{in}}^{\kappa_{\text{in}}(y, \mu)} \Omega_{\text{out}}^{\kappa_{\text{out}}(y, \mu)} \mu, \tau, \eta, 1)$ and $G_y(\xi) := (x, e_q, \mu, 0, \eta_0(o), 0)$. The functions $\kappa_{\text{in}}, \kappa_{\text{out}}$ are computed as follows

$$\begin{aligned} \kappa_{\text{in}}(y, \mu) &= \max\{0, \delta_{\text{in}}(y, \mu)\} \left\lceil \frac{\log(\max\{|y|, \Delta_0\} / (\ell_{\text{in}} \mu))}{\log \Omega_{\text{in}}} \right\rceil \\ \kappa_{\text{out}}(y, \mu) &= \max\{0, \delta_{\text{out}}(y, \mu)\} \left\lceil \frac{\log(|y| / (\ell_{\text{out}} \mu))}{\log \Omega_{\text{out}}} \right\rceil, \end{aligned} \quad (13)$$

where $\delta_{\text{in}}(y, \mu) := \text{sgn}(\ell_{\text{in}} \mu - \max\{|y|, \Delta_0\})$, $\delta_{\text{out}}(y, \mu) := \text{sgn}(|y| - \ell_{\text{out}} \mu)$.

We note that when the zoom-in condition is satisfied, i.e. $\max\{|y|, \Delta_0\} < \ell_{\text{in}} \mu$, we have that $\delta_{\text{in}}(y, \mu) = 1$ and $\delta_{\text{out}}(y, \mu) = -1$. Consequently, $\kappa_{\text{out}}(y, \mu) = 0$ and hence μ is updated to $\mu^+ = \Omega_{\text{in}}^{\kappa_{\text{in}}(y, \mu)} \mu$ and the function $\kappa_{\text{in}}(y, \mu)$ ensures that $\max\{|y|, \Delta_0\} \geq \ell_{\text{in}} \mu^+$. Similarly, when the zoom-out condition is verified at t_k , i.e. $|y| > \ell_{\text{out}} \mu$, we have that $\delta_{\text{in}}(y, \mu) = -1$ and $\delta_{\text{out}}(y, \mu) = 1$. Then, $\kappa_{\text{in}}(y, \mu) = 0$ and μ is updated to $\mu^+ = \Omega_{\text{out}}^{\kappa_{\text{out}}(y, \mu)} \mu$ and the definition of $\kappa_{\text{out}}(y, \mu)$ ensures that $|y| \geq \ell_{\text{out}} \mu^+$. When neither of the zoom conditions is violated, i.e. $\max\{|y|, \Delta_0\} \geq \ell_{\text{in}} \mu$ and $|y| \leq \ell_{\text{out}} \mu$, we have that $\kappa_{\text{in}}(y, \mu) = \kappa_{\text{out}}(y, \mu) = 0$ and hence, $\mu^+ = \mu$.

Observe that, in view of (12), the boolean variable p ensures that the zoom variable μ is first updated before a transmission is allowed at any transmission instant $t_k, k \in \mathbb{N}$. For instance, when $\xi \in \mathcal{D}$ and $p = 0$, the system will jump according to the jump map $G_\mu(\xi)$ in which only the quantizer variable μ is updated and p is changed to 1. Consequently, the state ξ enters the jump set $\xi \in \mathcal{D}$ and $p = 1$ where the system jumps according to $G_y(\xi)$ in which a transmission is released and p is reset to 0. Hence, the same order of jumps is maintained at the next time instant $t_k, k \in \mathbb{N}$.

V. MAIN RESULT

A. Assumptions

We make the following assumption on system (12).

Assumption 2. Consider system (12). There exist $\varepsilon_x, \varepsilon_y, \varepsilon_w, \gamma > 0$ and a positive definite symmetric real matrix P such that

$$\begin{pmatrix} \Sigma & \star & \star \\ \mathcal{B}_1^T P & -\gamma^2 \mathbb{I}_{n_e} & \star \\ \mathcal{E}_1^T P + \mathcal{E}_2^T \mathcal{A}_2 & 0 & \mathcal{E}_2^T \mathcal{E}_2 - \varepsilon_w \mathbb{I}_{n_w} \end{pmatrix} \leq 0, \quad (14)$$

where $\Sigma := \mathcal{A}_1^T P + P \mathcal{A}_1 + \varepsilon_x \mathbb{I}_{n_x} + \mathcal{A}_2^T \mathcal{A}_2 + \varepsilon_y \overline{C}_p^T \overline{C}_p$ with $\overline{C}_p := [C_p \quad 0]$. \square

Assumption 2 establishes an \mathcal{L}_2 -gain stability property for the system $\dot{x} = \mathcal{A}_1 x + \mathcal{B}_1 e + \mathcal{E}_1 w$ from $(|e|, |w|)$ to $(|\mathcal{A}_2 x + \mathcal{B}_2 e + \mathcal{E}_2 w|, |y|)$, see also, e.g., [1], [4], [5].

B. Design conditions for the event-triggering mechanism

The dynamics of the triggering function η in (7) is defined by the functions Ψ and η_0 , which are given by, see also [5]

$$\begin{aligned} \Psi(o) &:= \begin{cases} \varepsilon_y \max\{|y|^2, \Delta_0^2\} - \vartheta \eta, & \tau \in [0, T], \\ \varepsilon_y \max\{|y|^2, \Delta_0^2\} - \tilde{\gamma} |e|^2 - \vartheta \eta, & \tau \geq T \end{cases} \\ \eta_0(e) &:= \gamma(\tilde{\lambda} - \lambda) |e|^2, \end{aligned} \quad (15)$$

where $o := (y, e, \tau, \eta)$, $\vartheta > 0$ can be arbitrarily chosen, $\lambda \in (0, 1)$, $\tilde{\lambda} \in [\lambda, \lambda^{-1}]$, $\tilde{\gamma} := \gamma^2 + \gamma^2 \tilde{\lambda}^2 + 2\gamma \tilde{\lambda} \tilde{L}$ with $\tilde{L} := L + \nu$ for any $\nu > 0$ and $L := |\mathcal{B}_2|$, and the constant γ comes from Assumption 2. The constant time T is given

by $T = \mathcal{T}(\lambda, \tilde{\lambda}, \gamma, \tilde{L})$, where

$$\mathcal{T}(\lambda, \tilde{\lambda}, \gamma, \tilde{L}) := \begin{cases} \frac{1}{\tilde{L}r} \arctan\left(\frac{r(1-\lambda\tilde{\lambda})}{\tilde{L}(\lambda+\tilde{\lambda})+1+\lambda\tilde{\lambda}}\right) & \gamma > \tilde{L} \\ \frac{1}{\tilde{L}} \frac{1-\lambda\tilde{\lambda}}{\lambda\tilde{\lambda}+\lambda+\tilde{\lambda}+1} & \gamma = \tilde{L} \\ \frac{1}{\tilde{L}r} \operatorname{arctanh}\left(\frac{r(1-\lambda\tilde{\lambda})}{\tilde{L}(\lambda+\tilde{\lambda})+1+\lambda\tilde{\lambda}}\right) & \gamma < \tilde{L} \end{cases} \quad (16)$$

with $r := \sqrt{\left(\frac{\gamma}{\tilde{L}}\right)^2 - 1}$. The time $\mathcal{T}(\lambda, \tilde{\lambda}, \gamma, \tilde{L})$ corresponds to the *maximally allowable transmission interval (MATI)* of time-triggered controllers [4]. The expression of \mathcal{T} in (16), we drop the arguments of \mathcal{T} for brevity, is derived as the time \mathcal{T} it takes for a decreasing function $\phi: \mathbb{R}_{\geq 0} \rightarrow \mathbb{R}_{\geq 0}$ to decrease from $\phi(0) = \lambda^{-1}$ to $\phi(\mathcal{T}) = \tilde{\lambda}$, where ϕ has the dynamics, see also [4]

$$\frac{d\phi}{d\tau} := \begin{cases} -2\tilde{L}\phi(\tau) - \gamma(\phi^2(\tau) + 1) & \tau \in [0, T] \\ 0 & \tau \geq T. \end{cases} \quad (17)$$

Note that when $\tilde{\lambda} = \lambda$ in (16), we recover the MATI bound of the time-triggered controllers in [4].

We observe that, in view of (16), when $\tilde{\lambda} \in [\lambda, \lambda^{-1})$ is increased, the guaranteed minimum time T between two transmission instants will be reduced. However, by increasing $\tilde{\lambda}$, the value of η_0 in (15) will increase. Consequently, this may lead to increase the time it takes for η to decrease to 0, i.e. may enlarge the inter-transmission times. Hence, the tuning of $\tilde{\lambda}$ may generate a tradeoff between the guaranteed minimum inter-transmission time T and the average transmission times.

C. Design conditions for the dynamic quantizer

We design the quantizer initial range M , the initial resolution Δ , the zoom-in parameters $\ell_{\text{in}}, \Omega_{\text{in}}$, and the zoom-out parameters $\ell_{\text{out}}, \Omega_{\text{out}}$ as follows, for some $\kappa > 1$

$$M \geq (\kappa + 2\sqrt{\tilde{\gamma}}/(\sqrt{\varepsilon_y}\Omega_{\text{in}}\lambda))\Delta \quad (18)$$

$$\ell_{\text{in}} = \Omega_{\text{in}}(M - \kappa\Delta), \quad \ell_{\text{out}} = M - \Delta \quad (19)$$

$$\kappa > \max\{1, ((\Omega_{\text{in}}\Omega_{\text{out}} - 1)M + \Delta)/(\Omega_{\text{in}}\Omega_{\text{out}}\Delta)\} \quad (20)$$

for any $\Omega_{\text{in}} \in (0, 1)$ and $\Omega_{\text{out}} > 1$ such that (20) holds.

Condition (18) means that the quantizer has sufficiently many quantization regions such that the quantizer initial range M becomes sufficiently large compared to the initial resolution Δ . Condition (19) is used to define the zoom-in and the zoom-out surfaces, and satisfies $0 < \ell_{\text{in}} < \ell_{\text{out}} < M$. Condition (20) is useful to ensure that the chattering-like behaviour between the zoom-in and the zoom-out actions does not occur. Note that (20) simply holds if we take Ω_{in} and Ω_{out} such that $\Omega_{\text{in}}\Omega_{\text{out}} \leq 1$.

D. Stability result

We obtain the following result. The proof is omitted due to space constraints.

Theorem 1. *Consider system (12) with the flow and the jump sets as in (11) with Ψ, η_0 specified in (15) and $T = \mathcal{T}(\lambda, \tilde{\lambda}, \gamma, \tilde{L})$ with $\mathcal{T}(\lambda, \tilde{\lambda}, \gamma, \tilde{L})$ as defined in (16). Suppose*

that Assumptions 1, 2 are satisfied and the dynamic quantizer is designed as in (18)-(20). Then for any $w \in \mathcal{L}_{\infty}$ and $\xi(0, 0) \in \mathcal{X}$ with $\mathcal{X} := \{\xi \in \mathbb{X} \mid e = 0, \tau = 0, \eta = 0, p = 0\}$, it holds that

- (1) for all $(t, j) \in \text{dom } \xi$ and $\xi(t, j) \in \mathcal{D}_y$ with $p = 1$, $|e_s(t, j)| > \Delta\mu(t, j) \geq |e_q(t, j)|$;
- (2) the set $\mathcal{A} = \{\xi \in \mathbb{X} : R(\xi) \leq c\}$ is *input-to-state stable* w.r.t. w , where $R(\xi) := x^T P x + \gamma\phi|e|^2 + \eta$ with $c := \left(\frac{\lambda_{\max}(P)\tilde{\gamma}}{\varepsilon\varepsilon_x} + \gamma\tilde{\lambda}\right)\tilde{\Delta}_0^2$ for any $\tilde{\Delta}_0 \geq \sqrt{\frac{\varepsilon_y}{\tilde{\gamma}}}\Delta_0$, $\varepsilon \in (0, 1)$ and $P, \gamma, \varepsilon_x, \varepsilon_y$ as in Assumption 2;
- (3) the zoom-in/zoom-out condition is not immediately violated after the zoom-out/zoom-in action;
- (4) the hybrid signals $\mu, \kappa_{\text{in}}(y, \mu)$ and $\kappa_{\text{out}}(y, \mu)$ are all in \mathcal{L}_{∞} ;
- (5) solutions are *t-complete*, i.e. $\sup_t \text{dom } \xi = \infty$. □

Property (1) states that at each transmission instant, the current quantized information is not exactly the same as the previously transmitted value as $|e_s(t, j)| > |e_q(t, j)|$. Property (2) means that an ISS with respect to w is guaranteed for the set \mathcal{A} whose size depends on Δ_0 . This is due to the fact that μ does not eventually go to 0 since we stop zooming-in when $\mu < \frac{\Delta_0}{\ell_{\text{in}}}$ according to (9), which is also the case in, e.g., [11], [12]. Property (3) means that chattering-like behaviour between the zoom-in and the zoom-out stages does not occur. Property (4) shows that the zoom variable μ remains bounded and the values of $\kappa_{\text{in}}(y, \mu)$ and $\kappa_{\text{out}}(y, \mu)$, which will be transmitted, are finite. Finally, property (5) means that the time domain of solutions to system (11)-(12) is unbounded.

Remark 1. *Note that, in view of (16), (18), the design parameter λ creates a tradeoff between transmissions and quantization. When λ is reduced, the value of T in (16) will increase, which may result in a reduction in the amount of transmissions. However, by reducing λ , the right-hand side of (18) will also increase. Hence, the value of Δ needs to be decreased, i.e. finer quantization is required, in order to ensure that (18) holds. □*

VI. ILLUSTRATIVE EXAMPLE

Consider the LTI system (4)-(5) with $A_p = \begin{bmatrix} 0 & 1 \\ -2 & -1 \end{bmatrix}$, $B_p = \begin{bmatrix} 0 \\ -1 \end{bmatrix}$, $C_p = [1 \ 0]$, $E_p = \begin{bmatrix} 0 \\ 1 \end{bmatrix}$, $A_c = \begin{bmatrix} 0 & -2 \\ 0 & -3 \end{bmatrix}$, $B_c = \begin{bmatrix} 0 \\ 1 \end{bmatrix}$, $C_c = [-1 \ -2]$, and $D_c = 0$. By following the analysis in Section IV, we derive the hybrid model (12). Then, by solving the LMI (14), we obtain $\varepsilon_y = 0.678$, $L = 0$, $\gamma = 4.9655$. We take $\lambda = 0.5$, $\tilde{\lambda} = 0.6$, $\nu = 0.01$ and we compute the value of T by using (16), which yields $T = 0.1139$. Furthermore, we obtain $\tilde{\gamma} = 33.5917$. Finally, we set $\vartheta = 0.01$ and hence all the required parameters for the event-triggering functions in (15) are defined. Next, we set the range of the quantizer to be $M = 100$ and we take $\Delta = 1.5$, $\Delta_0 = 10^{-8}$, $\Omega_{\text{in}} = 0.5$, $\Omega_{\text{out}} = 2$ and $\kappa = 2$, which verify (18), (20) and lead to $\ell_{\text{in}} = 48.5$ and

$\ell_{\text{out}} = 98.5$. We run simulations for 50 seconds with the initial conditions $x(0, 0) = (-20, 20, 10, -10)$, $e(0, 0) = 0$, $\eta(0, 0) = 0$, $\tau(0, 0) = 0$, $\mu(0, 0) = 1$ and with random disturbances w satisfying $|w| \leq 0.5$. The observed minimum inter-transmission time is $\tau_{\min} = 0.1295$ and the average inter-transmission times is $\tau_{\text{avg}} = 0.3218$. We note that $\tau_{\min} > T$, which supports the discussion in Section V-B on the choice of λ . The state trajectories of the plant and the dynamic controller are shown in Fig. 2, where the state asymptotically converges to a small neighbourhood to the origin. Fig. 3 shows that the zoom actions are only implemented at transmission instants and the constant time T acts as a lower bound on both the inter-transmission and the inter-zoom times. The tradeoff between transmissions and quantization is presented in Fig. 4. We note that smaller values of Δ , i.e. more quantized regions, leads to larger values of T , i.e. the guaranteed minimum time between two consecutive transmissions/zooms is enlarged, and vice versa, see Remark 1.

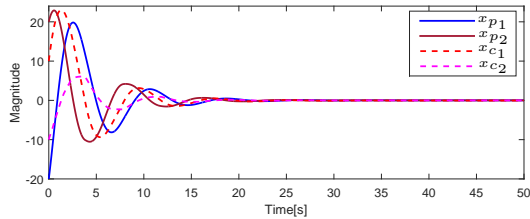

Fig. 2. State trajectory for the plant and the controller.

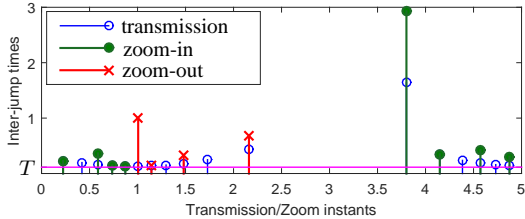

Fig. 3. Transmission/Zoom instants for the first 5 s.

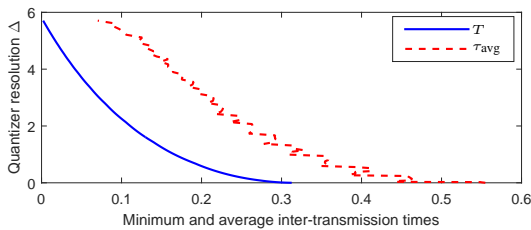

Fig. 4. Tradeoff curve between quantization, Δ , and transmissions, T , T_{avg} .

VII. CONCLUSION

We have considered input-to-state stabilization of linear systems with quantized output feedback and using event-triggered controllers to reduce the network utilization. The proposed approach ensures the existence of a strictly positive lower bound on the inter-transmission times and on the inter-zoom times. The zoom parameter of the dynamic quantizer is shown to be bounded. Chattering between the zoom-in and

the zoom-out actions is avoided and the redundant access of the network is prevented. Future work will focus on the extension of the obtained result to the case where the plant output is distributed and transmitted over different channels.

REFERENCES

- [1] M. Abdelrahim, R. Postoyan, J. Daafouz, and D. Nešić. Input-to-state stabilization of nonlinear systems using event-triggered output feedback controllers. *In Proceedings of the 14th European Control Conference, Linz, Austria*, pages 2185–2190, 2015.
- [2] D.P. Borgers and W.P.M.H. Heemels. Event-separation properties of event-triggered control systems. *IEEE Transactions on Automatic Control*, 59(10):2644–2656, 2014.
- [3] C. Cai and A.R. Teel. Characterizations of input-to-state stability for hybrid systems. *Systems & Control Letters*, 58(1):47–53, 2009.
- [4] D. Carnevale, A.R. Teel, and D. Nešić. A Lyapunov proof of an improved maximum allowable transfer interval for networked control systems. *IEEE Transactions on Automatic Control*, 52(5):892–897, 2007.
- [5] V.S. Dolk, D.P. Borgers, and W.P.M.H. Heemels. Output-based and decentralized dynamic event-triggered control with guaranteed \mathcal{L}_p -gain performance and zero-freeness. *IEEE Transactions on Automatic Control*, to appear.
- [6] M.C.F. Donkers and W.P.M.H. Heemels. Output-based event-triggered control with guaranteed \mathcal{L}_∞ -gain and improved and decentralized event-triggering. *IEEE Transactions on Automatic Control*, 57(6):1362–1376, 2012.
- [7] A. Girard. Dynamic triggering mechanisms for event-triggered control. *IEEE Transactions on Automatic Control*, 60(7):1992–1997, 2015.
- [8] R. Goebel, R.G. Sanfelice, and A.R. Teel. *Hybrid Dynamical Systems: Modeling, Stability, and Robustness*. Princeton University Press, 2012.
- [9] W.P.M.H. Heemels, K.H. Johansson, and P. Tabuada. An introduction to event-triggered and self-triggered control. *In Proceedings of the 51st IEEE Conference on Decision and Control, Maui, U.S.A.*, pages 3270–3285, 2012.
- [10] W.P.M.H. Heemels, D. Nešić, and A.R. Teel. Networked and quantized control systems with communication delays. *In Proceedings of the joint 48th IEEE Conference on Decision and Control and 28th Chinese Control Conference, Shanghai, China*, pages 7929–7935, 2009.
- [11] D. Liberzon. Hybrid feedback stabilization of systems with quantized signals. *Automatica*, 39(9):1543–1554, 2003.
- [12] D. Liberzon and D. Nešić. Input-to-state stabilization of linear systems with quantized state measurements. *IEEE Transactions on Automatic Control*, 52(5):767–781, 2007.
- [13] T. Liu and Z. Jiang. Quantized event-based control of nonlinear systems. *In Proceedings of the 54th IEEE Conference on Decision and Control, Osaka, Japan*, pages 4806–4811, 2015.
- [14] D. Nešić and D. Liberzon. A unified framework for design and analysis of networked and quantized control systems. *IEEE Transactions on Automatic Control*, 54(4):732–747, 2009.
- [15] D. Nešić, A.R. Teel, G. Valmorbida, and L. Zaccarian. Finite-gain \mathcal{L}_p stability for hybrid dynamical systems. *Automatica*, 49(8):2384–2396, 2013.
- [16] R. Postoyan, P. Tabuada, D. Nešić, and A. Anta. A framework for the event-triggered stabilization of nonlinear systems. *IEEE Transactions on Automatic Control*, 60(4):982–996, 2015.
- [17] Y. Sharon and D. Liberzon. Input to state stabilizing controller for systems with coarse quantization. *IEEE Transactions on Automatic Control*, 57(4):830–844, 2012.
- [18] P. Tallapragada and J. Cortes. Event-triggered stabilization of linear systems under bounded bit rates. *In IEEE Transactions on Automatic Control*, to appear.
- [19] A. Tanwani, C. Prieur, and M. Fiacchini. Observer-based feedback stabilization of linear systems with event-triggered sampling and dynamic quantization. *Systems & Control Letters*, 94:46–56, 2016.