INSTANTANEOUS POWER THEORY AND APPLICATIONS TO POWER CONDITIONING

Hirofumi Akagi

*Professor of Electrical Engineering
TIT—Tokyo Institute of Technology, Japan*

Edson Hirokazu Watanabe

*Professor of Electrical Engineering
UFRJ—Federal University of Rio de Janeiro, Brazil*

Mauricio Aredes

*Associate Professor of Electrical Engineering
UFRJ—Federal University of Rio de Janeiro, Brazil*



Mohamed E. El-Hawary, *Series Editor*



WILEY-INTERSCIENCE
A JOHN WILEY & SONS, INC., PUBLICATION

**INSTANTANEOUS POWER
THEORY AND APPLICATIONS
TO POWER CONDITIONING**

IEEE Press
445 Hoes Lane
Piscataway, NJ 08854

IEEE Press Editorial Board

Mohamed E. El-Hawary, *Editor in Chief*

R. Abari

S. Basu

A. Chatterjee

T. Chen

T. G. Croda

S. Farshchi

S. V. Kartalopoulos

B. M. Hammerli

R. J. Herrick

M. S. Newman

N. Schulz

Kenneth Moore, *Director of IEEE Book and Information Services (BIS)*

Catherine Faduska, *Senior Acquisitions Editor*

Jeanne Audino, *Project Editor*

INSTANTANEOUS POWER THEORY AND APPLICATIONS TO POWER CONDITIONING

Hirofumi Akagi

*Professor of Electrical Engineering
TIT—Tokyo Institute of Technology, Japan*

Edson Hirokazu Watanabe

*Professor of Electrical Engineering
UFRJ—Federal University of Rio de Janeiro, Brazil*

Mauricio Aredes

*Associate Professor of Electrical Engineering
UFRJ—Federal University of Rio de Janeiro, Brazil*



Mohamed E. El-Hawary, *Series Editor*



WILEY-INTERSCIENCE
A JOHN WILEY & SONS, INC., PUBLICATION

Copyright © 2007 by the Institute of Electrical and Electronics Engineers, Inc. All rights reserved.

Published by John Wiley & Sons, Inc., Hoboken, New Jersey.
Published simultaneously in Canada.

No part of this publication may be reproduced, stored in a retrieval system, or transmitted in any form or by any means, electronic, mechanical, photocopying, recording, scanning, or otherwise, except as permitted under Section 107 or 108 of the 1976 United States Copyright Act, without either the prior written permission of the Publisher, or authorization through payment of the appropriate per-copy fee to the Copyright Clearance Center, Inc., 222 Rosewood Drive, Danvers, MA 01923, (978) 750-8400, fax (978) 750-4470, or on the web at www.copyright.com. Requests to the Publisher for permission should be addressed to the Permissions Department, John Wiley & Sons, Inc., 111 River Street, Hoboken, NJ 07030, (201) 748-6011, fax (201) 748-6008, or online at <http://www.wiley.com/go/permission>.

Limit of Liability/Disclaimer of Warranty: While the publisher and author have used their best efforts in preparing this book, they make no representations or warranties with respect to the accuracy or completeness of the contents of this book and specifically disclaim any implied warranties of merchantability or fitness for a particular purpose. No warranty may be created or extended by sales representatives or written sales materials. The advice and strategies contained herein may not be suitable for your situation. You should consult with a professional where appropriate. Neither the publisher nor author shall be liable for any loss of profit or any other commercial damages, including but not limited to special, incidental, consequential, or other damages.

For general information on our other products and services or for technical support, please contact our Customer Care Department within the United States at (800) 762-2974, outside the United States at (317) 572-3993 or fax (317) 572-4002.

Wiley also publishes its books in a variety of electronic formats. Some content that appears in print may not be available in electronic format. For information about Wiley products, visit our web site at www.wiley.com.

Library of Congress Cataloging-in-Publication Data is available.

ISBN 978-0-470-10761-4

Printed in the United States of America.

10 9 8 7 6 5 4 3 2 1

*This book is dedicated
to all the scientists and engineers who have participated in
the development of Instantaneous Power Theory and
Applications to Power Conditioning*

and

*to our families
Nobuko, Chieko, and Yukiko,
Yukiko, Edson Hiroshi, and Beatriz Yumi,
Marilia, Mariah, and Maynara.*

CONTENTS

Preface	xiii
1. Introduction	1
1.1. Concepts and Evolution of Electric Power Theory	2
1.2. Applications of the p - q Theory to Power Electronics Equipment	4
1.3. Harmonic Voltages in Power Systems	5
1.4. Identified and Unidentified Harmonic-Producing Loads	7
1.5. Harmonic Current and Voltage Sources	8
1.6. Basic Principles of Harmonic Compensation	11
1.7. Basic Principles of Power Flow Control	14
References	17
2. Electric Power Definitions: Background	19
2.1. Power Definitions Under Sinusoidal Conditions	20
2.2. Voltage and Current Phasors and the Complex Impedance	22
2.3. Complex Power and Power Factor	24
2.4. Concepts of Power Under Non-Sinusoidal Conditions— Conventional Approaches	25
2.4.1. Power Definitions by Budeanu	25
2.4.1.A. Power Tetrahedron and Distortion Factor	28
2.4.2. Power Definitions by Fryze	30
2.5. Electric Power in Three-Phase Systems	31
2.5.1. Classifications of Three-Phase Systems	31
2.5.2. Power in Balanced Three-Phase Systems	34
2.5.3. Power in Three-Phase Unbalanced Systems	36

2.6. Summary	37
References	38
3 The Instantaneous Power Theory	41
3.1. Basis of the p - q Theory	42
3.1.1. Historical Background of the p - q Theory	42
3.1.2. The Clarke Transformation	43
3.1.2.A. Calculation of Voltage and Current Vectors when Zero-Sequence Components are Excluded	45
3.1.3. Three-Phase Instantaneous Active Power in Terms of Clarke Components	47
3.1.4. The Instantaneous Powers of the p - q Theory	48
3.2. The p - q Theory in Three-Phase, Three-Wire Systems	49
3.2.1. Comparisons with the Conventional Theory	53
3.2.1.A. Example #1—Sinusoidal Voltages and Currents	53
3.2.1.B. Example #2—Balanced Voltages and Capacitive Loads	54
3.2.1.C. Example #3—Sinusoidal Balanced Voltage and Nonlinear Load	55
3.2.2. Use of the p - q Theory for Shunt Current Compensation	59
3.2.2.A. Examples of Appearance of Hidden Currents	64
3.2.2.A.1. Presence of the Fifth Harmonic in Load Current	64
3.2.2.A.2. Presence of the Seventh Harmonic in Load Current	67
3.2.3. The Dual p - q Theory	68
3.3. The p - q Theory in Three-Phase, Four-Wire Systems	71
3.3.1. The Zero-Sequence Power in a Three-Phase Sinusoidal Voltage Source	72
3.3.2. Presence of Negative-Sequence Components	74
3.3.3. General Case-Including Distortions and Imbalances in the Voltages and in the Currents	75
3.3.4. Physical Meanings of the Instantaneous Real, Imaginary, and Zero-Sequence Powers	79
3.3.5. Avoiding the Clarke Transformation in the p - q Theory	80
3.3.6. Modified p - q Theory	82
3.4. Instantaneous abc Theory	87
3.4.1. Active and Nonactive Current Calculation by Means of a Minimization Method	89
3.4.2. Generalized Fryze Currents Minimization Method	94
3.5. Comparisons between the p - q Theory and the abc Theory	98
3.5.1. Selection of Power Components to be Compensated	101
3.6. Summary	102
References	104

4 Shunt Active Filters	109
4.1. General Description of Shunt Active Filters	111
4.1.1. PWM Converters for Shunt Active Filters	112
4.1.2. Active Filter Controllers	113
4.2. Three-Phase, Three-Wire Shunt Active Filters	116
4.2.1. Active Filters for Constant Power Compensation	118
4.2.2. Active Filters for Sinusoidal Current Control	134
4.2.2.A. Positive-Sequence Voltage Detector	138
4.2.2.A.1 Main Circuit of the Voltage Detector	138
4.2.2.A.2 Phase-Locked-Loop (PLL) Circuit	141
4.2.2.B. Simulation Results	145
4.2.3. Active Filters for Current Minimization	145
4.2.4. Active Filters for Harmonic Damping	150
4.2.4.A. Shunt Active Filter Based on Voltage Detection	151
4.2.4.B. Active Filter Controller Based on Voltage Detection	152
4.2.4.C. An Application Case of Active Filter for Harmonic Damping	157
4.2.4.C.1 The Power Distribution Line for the Test Case	158
4.2.4.C.2 The Active Filter for Damping of Harmonic Propagation	159
4.2.4.C.3 Experimental Results	160
4.2.4.C.4 Adjust of the Active Filter Gain	168
4.2.5. A Digital Controller	173
4.2.5.A. System Configuration of the Digital Controller	174
4.2.5.A.1 Operating Principle of PLL and PWM Units	175
4.2.5.A.2 Sampling Operation in the A/D Unit	177
4.2.5.B. Current Control Methods	178
4.2.5.B.1 Modeling of Digital Current Control	178
4.2.5.B.2 Proportional Control	179
4.2.5.B.3 Deadbeat Control	180
4.2.5.B.4 Frequency Response of Current Control	181
4.3. Three-Phase, Four-Wire Shunt Active Filters	182
4.3.1. Converter Topologies for Three-Phase, Four-Wire Systems	183
4.3.2. Dynamic Hysteresis-Band Current Controller	184
4.3.3. Active Filter Dc Voltage Regulator	186
4.3.4. Optimal Power Flow Conditions	187
4.3.5. Constant Instantaneous Power Control Strategy	189
4.3.6. Sinusoidal Current Control Strategy	192
4.3.7. Performance Analysis and Parameter Optimization	195
4.3.7.A. Influence of the System Parameters	195
4.3.7.B. Dynamic Response of the Shunt Active Filter	196

4.3.7.C. Economical Aspects	201
4.3.7.D. Experimental Results	203
4.4. Shunt Selective Harmonic Compensation	208
4.5. Summary	216
References	217
5 Hybrid and Series Active Filters	221
5.1. Basic Series Active Filter	221
5.2. Combined Series Active Filter and Shunt Passive Filter	223
5.2.1. Example of An Experimental System	226
5.2.1.A. Compensation Principle	226
5.2.1.A.1 Source Harmonic Current \dot{I}_{Sh}	228
5.2.1.A.2 Output Voltage of Series Active Filter: \dot{V}_C	229
5.2.1.A.3 Shunt Passive Filter Harmonic Voltage: \dot{V}_{Fh}	229
5.2.1.B. Filtering Characteristics	230
5.2.1.B.1 Harmonic Current Flowing From the Load to the Source	230
5.2.1.B.2 Harmonic Current Flowing from the Source to the Shunt Passive Filter	231
5.2.1.C. Control Circuit	231
5.2.1.D. Filter to Suppress Switching Ripples	233
5.2.1.E. Experimental Results	234
5.2.2. Some Remarks about the Hybrid Filters	237
5.3. Series Active Filter Integrated with a Double-Series Diode Rectifier	238
5.3.1. The First-Generation Control Circuit	241
5.3.1.A. Circuit Configuration and Delay Time	241
5.3.1.B. Stability of the Active Filter	242
5.3.2. The Second-Generation Control Circuit	244
5.3.3. Stability Analysis and Characteristics Comparison	246
5.3.3.A. Transfer Function of the Control Circuits	246
5.3.3.B. Characteristics Comparisons	247
5.3.4. Design of a Switching-Ripple Filter	248
5.3.4.A. Design Principle	248
5.3.4.B. Effect on the System Stability	250
5.3.4.C. Experimental Testing	251
5.3.5. Experimental Results	252
5.4. Comparisons Between Hybrid and Pure Active Filters	253
5.4.1. Low-Voltage Transformerless Hybrid Active Filter	255
5.4.2. Low-Voltage Transformerless Pure Shunt Active Filter	258
5.4.3. Comparisons Through Simulation Results	259
5.5. Conclusions	261
References	262

6 Combined Series and Shunt Power Conditioners	265
6.1. The Unified Power Flow Controller (UPFC)	267
6.1.1. FACTS and UPFC Principles	268
6.1.1.A. Voltage Regulation Principle	269
6.1.1.B. Power Flow Control Principle	270
6.1.2. A Controller Design for the UPFC	274
6.1.3. UPFC Approach Using a Shunt Multipulse Converter	281
6.1.3.A. Six-Pulse Converter	282
6.1.3.B. Quasi 24-Pulse Converter	286
6.1.3.C. Control of Active and Reactive Power in Multipulse Converters	288
6.1.3.D. Shunt Multipulse Converter Controller	290
6.2. The Unified Power Quality Conditioner (UPQC)	293
6.2.1. General Description of the UPQC	294
6.2.2. A Three-Phase, Four-Wire UPQC	297
6.2.2.A. Power Circuit of the UPQC	297
6.2.2.B. The UPQC Controller	299
6.2.2.B.1 PWM Voltage Control with Minor Feedback Control Loop	300
6.2.2.B.2 Series Active Filter Controller	301
6.2.2.B.3 Integration of the Series and Shunt Active Filter Controllers	305
6.2.2.B.4 General Aspects	307
6.2.2.C. Analysis of the UPQC Dynamic	308
6.2.2.C.1 Optimizing the Power System Parameters	309
6.2.2.C.2 Optimizing the Parameters in the Control Systems	311
6.2.2.C.3 Simulation Results	312
6.2.2.C.4 Experimental Results	320
6.2.3. The UPQC Combined with Passive Filters (Hybrid UPQC)	326
6.2.3.A. Controller of the Hybrid UPQC	331
6.2.3.B. Experimental Results	337
6.3. The Universal Active Power Line Conditioner (UPLC)	343
6.3.1. General Description of the UPLC	344
6.3.2. The Controller of the UPLC	347
6.3.2.A. Controller for the Configuration #2 of UPLC	355
6.3.3. Performance of the UPLC	355
6.3.3.A. Normalized System Parameters	355
6.3.3.B. Simulation Results of Configuration #1 of UPLC	360
6.3.3.C. Simulation Results of Configuration #2 of UPLC	368
6.3.4. General Aspects	370
6.4. Summary	371
References	371
Index	375

PREFACE

The concept of “instantaneous active and reactive power” was first presented in 1982 in Japan. Since then, many scientists and engineers have made significant contributions to its modifications in three-phase, four-wire circuits, its expansions to more than three-phase circuits, and its applications to power electronics equipment. However, neither a monograph nor book on this subject has been available in the market. Filling this gap was the main motivation for writing this book. The instantaneous power theory, or simply “the p - q theory,” makes clear the physical meaning of what the instantaneous active and reactive power is in a three-phase circuit. Moreover, it provides a clear insight into how energy flows from a source to a load, or circulates between phases, in a three-phase circuit.

At the beginning of writing this book, we decided to try to present the basic concepts of the theory as didactically as possible. Hence, the book was structured to present in Chapter 1 the problems related to nonlinear loads and harmonics. Chapter 2 describes the background of electrical power definitions based on conventional theories. Then, Chapter 3 deals with the instantaneous power theory. In this chapter, special attention is paid to the effort to offer abundant materials intended to make the reader understand the theory, particularly for designing controllers for active filters for power conditioning. Part of Chapter 3 is dedicated to presenting alternative sets of instantaneous power definitions. One of the alternatives, called the “modified p - q theory,” expands the original imaginary power definition to an instantaneous imaginary power vector with three components. Another approach, called in this book the “ abc theory,” uses the abc -phase voltages and currents directly to define the active and nonactive current components. Comparisons in difference and physical meaning between these theories conclude Chapter 3.

Chapter 4 is exclusively dedicated to shunt active filters with different filter structures, showing clearly whether energy storage elements such as capacitors and inductors are necessary or not, and how much they are theoretically dispensable to the active filters. This consideration of the energy storage elements is one of the strongest points in the instantaneous power theory. Chapter 5 addresses series active filters, including hybrid configurations of active and passive filters. The hybrid configurations may provide an economical solution to harmonic filtering, particularly in medium-voltage, adjustable-speed motor drives.

Chapter 6 presents combined series and shunt power conditioners, including the unified power quality conditioner (UPQC), and the unified power flow controller (UPFC) that is a FACTS (flexible ac transmission system) device. Finally, it leads to the universal active power line conditioner (UPLC) that integrates the UPQC with the UPFC in terms of functionality.

Pioneering applications of the p - q theory to power conditioning are illustrated throughout the book, which helps the reader to understand the substantial nature of the instantaneous power theory, along with distinct differences from conventional theories.

The authors would like to acknowledge the encouragement and support received from many colleagues in various forms. The first author greatly appreciates his former colleagues, Prof. A. Nabae, the late Prof. I. Takahashi, and Mr. Y. Kanazawa at the Nagaoka University of Technology, where the p - q theory was born in 1982 and research on its applications to pure and hybrid active filters was initiated to spur many scientists and engineers to do further research on theory and practice.

The long distance between the homelands of the authors was not a serious problem because research-supporting agencies like CNPq (Conselho Nacional de Desenvolvimento Científico e Tecnológico) and JSPS (the Japan Society for the Promotion of Science) gave financial support for the authors to travel to Brazil or to Japan when a conference was held in one of these countries. Thus, the authors were able to meet and discuss face to face the details of the book, which would not be easily done over the Internet. The support received from the Fundação de Amparo à Pesquisa do Estado do Rio de Janeiro (FAPERJ) is also acknowledged.

Finally, our special thanks go to the following former graduate students and visiting scientists who worked with the authors: S. Ogasawara, K. Fujita, T. Tanaka, S. Atoh, F. Z. Peng, Y. Tsukamoto, H. Fujita, S. Ikeda, T. Yamasaki, H. Kim, K. Wada, P. Jintakosonwit, S. Srianthumrong, Y. Tamai, R. Inzunza, and G. Casaravilla, who are now working in industry or academia. They patiently helped to develop many good ideas, to design and build experimental systems, and to obtain experimental results. Without their enthusiastic support, the authors could not have published this book.

H. AKAGI, E. H. WATANABE, AND M. AREDES

Tokyo/Rio de Janeiro, August, 2006

CHAPTER 1

INTRODUCTION

The instantaneous active and reactive power theory, or the so-called “ p - q Theory,” was introduced by Akagi, Kanazawa, and Nabae in 1983. Since then, it has been extended by the authors of this book, as well as other research scientists. This book deals with the theory in a complete form for the first time, including comparisons with other sets of instantaneous power definitions. The usefulness of the p - q Theory is confirmed in the following chapters dealing with applications in controllers of compensators that are generically classified here as active power line conditioners.

The term “power conditioning” used in this book has much broader meaning than the term “harmonic filtering.” In other words, the power conditioning is not confined to harmonic filtering, but contains harmonic damping, harmonic isolation, harmonic termination, reactive-power control for power factor correction, power flow control, and voltage regulation, load balancing, voltage-flicker reduction, and/or their combinations. Active power line conditioners are based on leading-edge power electronics technology that includes power conversion circuits, power semiconductor devices, analog/digital signal processing, voltage/current sensors, and control theory.

Concepts and evolution of electric power theory are briefly described below. Then, the need for a consistent set of power definitions is emphasized to deal with electric systems under nonsinusoidal conditions. Problems with harmonic pollution in alternating current systems (ac systems) are classified, including a list of the principal harmonic-producing loads. Basic principles of harmonic compensation are introduced. Finally, this chapter describes the fundamentals of power flow control. All these topics are the subjects of scope, and will be discussed deeply in the following chapters of the book.

1.1. CONCEPTS AND EVOLUTION OF ELECTRIC POWER THEORY

One of main points in the development of alternating current (ac) transmission and distribution power systems at the end of the 19th century was based on sinusoidal voltage at constant-frequency generation. Sinusoidal voltage with constant frequency has made easier the design of transformers and transmission lines, including very long distance lines. If the voltage were not sinusoidal, complications would appear in the design of transformers, machines, and transmission lines. These complications would not allow, certainly, such a development as the generalized “electrification of the human society.” Today, there are very few communities in the world without ac power systems with “constant” voltage and frequency.

With the emergence of sinusoidal voltage sources, the electric power network could be made more efficient if the load current were in phase with the source voltage. Therefore, the concept of reactive power was defined to represent the quantity of electric power due to the load current that is not in phase with the source voltage. The average of this reactive power during one period of the line frequency is zero. In other words, this power does not contribute to energy transfer from the source to the load. At the same time, the concepts of apparent power and power factor were created. Apparent power gives the idea of how much power can be delivered or consumed if the voltage and current are sinusoidal and perfectly in phase. The power factor gives a relation between the average power actually delivered or consumed in a circuit and the apparent power at the same point. Naturally, the higher the power factor, the better the circuit utilization. As a consequence, the power factor is more efficient not only electrically but also economically. Therefore, electric power utilities have specified lower limits for the power factor. Loads operated at low power factor pay an extra charge for not using the circuit efficiently.

For a long time, one of the main concerns related to electric equipment was power factor correction, which could be done by using capacitor banks or, in some cases, reactors. For all situations, the load acted as a linear circuit drawing a sinusoidal current from a sinusoidal voltage source. Hence, the conventional power theory based on active-, reactive- and apparent-power definitions was sufficient for design and analysis of power systems. Nevertheless, some papers were published in the 1920s, showing that the conventional concept of reactive and apparent power loses its usefulness in nonsinusoidal cases [1,2]. Then, two important approaches to power definitions under nonsinusoidal conditions were introduced by Budeanu [3,4], in 1927 and Fryze [5] in 1932. Fryze defined power in the time domain, whereas Budeanu did it in the frequency domain. At that time, nonlinear loads were negligible, and little attention was paid to this matter for a long time.

Since power electronics was introduced in the late 1960s, nonlinear loads that consume nonsinusoidal current have increased significantly. In some cases, they represent a very high percentage of the total loads. Today, it is common to find a house without linear loads such as conventional incandescent lamps. In most cases, these lamps have been replaced by electronically controlled fluorescent lamps. In industrial applications, an induction motor that can be considered as a linear load in

a steady state is now equipped with a rectifier and inverter for the purpose of achieving adjustable-speed control. The induction motor together with its drive is no longer a linear load. Unfortunately, the previous power definitions under nonsinusoidal currents were dubious, thus leading to misinterpretations in some cases. Chapter 2 presents a review of some theories dealing with nonsinusoidal conditions.

As pointed out above, the problems related to nonlinear loads have significantly increased with the proliferation of power electronics equipment. The modern equipment behaves as a nonlinear load drawing a significant amount of harmonic current from the power network. Hence, power systems in some cases have to be analyzed under nonsinusoidal conditions. This makes it imperative to establish a consistent set of power definitions that are also valid during transients and under nonsinusoidal conditions.

The power theories presented by Budeanu [3,4] and Fryze [5] had basic concerns related to the calculation of average power or root-mean-square values (rms values) of voltage and current. The development of power electronics technology has brought new boundary conditions to the power theories. Exactly speaking, the new conditions have not emerged from the research of power electronics engineers. They have resulted from the proliferation of power converters using power semiconductor devices such as diodes, thyristors, insulated-gate bipolar transistors (IGBTs), gate-turn-off (GTO) thyristors, and so on. Although these power converters have a quick response in controlling their voltages or currents, they may draw reactive power as well as harmonic current from power networks. This has made it clear that conventional power theories based on average or rms values of voltages and currents are not applicable to the analysis and design of power converters and power networks. This problem has become more serious and clear during comprehensive analysis and design of active filters intended for reactive-power compensation as well as harmonic compensation.

From the end of the 1960s to the beginning of the 1970s, Erlicki and Emanuel-Eigeles [6], Sasaki and Machida [7], and Fukao, Iida, and Miyairi [8] published their pioneer papers presenting what can be considered as a basic principle of controlled reactive-power compensation. For instance, Erlicki and Emanuel-Eigeles [6] presented some basic ideas like “compensation of distortive power is unknown to date. . . .” They also determined that “a non-linear resistor behaves like a reactive-power generator while having no energy-storing elements,” and presented the very first approach to active power-factor control. Fukao, Iida and Miyairi [8] stated that “by connecting a reactive-power source in parallel with the load, and by controlling it in such a way as to supply reactive power to the load, the power network will only supply active power to the load. Therefore, ideal power transmission would be possible.”

Gyugyi and Pelly [9] presented the idea that reactive power could be compensated by a naturally commutated cycloconverter without energy storage elements. This idea was explained from a physical point of view. However, no specific mathematical proof was presented. In 1976, Harashima, Inaba, and Tsuboi [10] presented, probably for the first time, the term “instantaneous reactive power” for a single-phase circuit. That same year, Gyugyi and Strycula [11] used the term “active ac power filters” for the first time. A few years later, in 1981, Takahashi, Fujiwara,

and Nabae published two papers [12,13] giving a hint of the emergence of the instantaneous power theory or “ p - q Theory.” In fact, the formulation they reached can be considered a subset of the p - q Theory that forms the main scope of this book. However, the physical meaning of the variables introduced to the subset was not explained by them.

The p - q Theory in its first version was published in the Japanese language in 1982 [14] in a local conference, and later in *Transactions of the Institute of Electrical Engineers of Japan* [15]. With a minor time lag, a paper was published in English in an international conference in 1983 [16], showing the possibility of compensating for instantaneous reactive power without energy storage elements. Then, a more complete paper including experimental verifications was published in the *IEEE Transactions on Industry Applications* in 1984 [17].

The p - q Theory defines a set of instantaneous powers in the time domain. Since no restrictions are imposed on voltage or current behaviors, it is applicable to three-phase systems with or without neutral conductors, as well as to generic voltage and current waveforms. Thus, it is valid not only in steady states, but also during transient states. Contrary to other traditional power theories treating a three-phase system as three single-phase circuits, the p - q Theory deals with all the three phases at the same time, as a unity system. Therefore, this theory always considers three-phase systems together, not as a superposition or sum of three single-phase circuits. It was defined by using the $\alpha\beta 0$ -transformation, also known as the Clarke Transformation [18], which consists of a real matrix that transforms three-phase voltages and currents into the $\alpha\beta 0$ -stationary reference frames. As will be seen in this book, the p - q Theory provides a very efficient and flexible basis for designing control strategies and implementing them in the form of controllers for power conditioners based on power electronics devices.

There are other approaches to power definitions in the time domain. Chapter 3 is dedicated to the time-domain analysis of power in three-phase circuits, and it is especially dedicated to the p - q Theory.

1.2. APPLICATIONS OF THE p - q THEORY TO POWER ELECTRONICS EQUIPMENT

The proliferation of nonlinear loads has spurred interest in research on new power theories, thus leading to the p - q Theory. This theory can be used for the design of power electronics devices, especially those intended for reactive-power compensation. Various problems related to harmonic pollution in power systems have been investigated and discussed for a long time. These are listed as follows:

- *Overheating of transformers and electrical motors.* Harmonic components in voltage and/or current induce high-frequency magnetic flux in their magnetic core, thus resulting in high losses and overheating of these electrical machines. It is common to oversize transformers and motors by 5 to 10% to overcome this problem [19].

- *Overheating of capacitors for power-factor correction.* If the combination of line reactance and the capacitor for power-factor correction has a resonance at the same frequency as a harmonic current generated by a nonlinear load, an overcurrent may flow through the capacitor. This may overheat it, possibly causing damage.
- *Voltage waveform distortion.* Harmonic current may cause voltage waveform distortion that can interfere with the operation of other electronic devices. This is a common fact when rectifiers are used. Rectifier currents distort the voltage waveforms with notches that may change the zero-crossing points of the voltages. This can confuse the rectifier control circuit itself, or the control circuit of other equipment.
- *Voltage flicker.* In some cases, the harmonic spectra generated by nonlinear loads have frequency components below the line frequency. These undesirable frequency components, especially in a frequency range of 8 to 30 Hz, may cause a flicker effect in incandescent lamps, which is a very uncomfortable effect for people's eyes. The arc furnace is one of the main contributors to this kind of problem.
- *Interference with communication systems.* Harmonic currents generated by nonlinear loads may interfere with communication systems like telephones, radios, television sets, and so on.

In the past, these problems were isolated and few. Nowadays, with the increased number of nonlinear loads present in the electric grid, they are much more common. On the other hand, the need for highly efficient and reliable systems has forced researchers to find solutions to these problems. In many cases, harmonic pollution cannot be tolerated.

As will be shown in Chapter 3, the p - q Theory that defines the instantaneous real and imaginary powers is a flexible tool, not only for harmonic compensation, but also for reactive-power compensation. For instance, FACTS (Flexible AC Transmission System) equipment that was introduced in [20] can be better understood if one has a good knowledge of the p - q Theory.

All these problems have encouraged the authors to write this book, which contributes to harmonic elimination from power systems. Moreover, an interesting application example of the p - q Theory will be presented, dealing with power flow control in a transmission line. This theory can also be used to control grid-connected converters like those used in solar energy systems [21], and can also be extended to other distributed power generation systems such as wind energy systems and fuel cells.

1.3. HARMONIC VOLTAGES IN POWER SYSTEMS

Tables 1-1 and 1-2 show the maximum and minimum values of total harmonic distortion (THD) in voltage and dominant voltage harmonics in a typical power system

Table 1-1. THD in voltage and 5th harmonic voltage in a high-voltage power transmission system

	Over 187 kV		154–22 kV	
	THD	5th harmonic	THD	5th harmonic
Maximum	2.8 %	2.8 %	3.3 %	3.2 %
Minimum	1.1 %	1.0 %	1.4 %	1.3 %

in Japan, measured in October 2001 [22]. The individual harmonic voltages and the resulting THD in high-voltage power transmission systems tend to be less than those in the 6.6-kV power distribution system. The primary reason is that the expansion and interconnection of high-voltage power transmission systems has made the systems stiffer with an increase of short-circuit capacity. For the distribution system, the maximum value of 5th harmonic voltage in a commercial area that was investigated exceeded its allowable level of 3%, considering Japanese guidelines, while the maximum THD value in voltage was marginally lower than its allowable level of 5%.

According to [23], the maximum value of 5th harmonic voltage in the downtown area of a 6.6-kV power distribution system in Japan exceeds 7% under light-load conditions at night. They also have pointed out another significant phenomenon. The 5th harmonic voltage increases on the 6.6-kV bus at the secondary of the power transformer installed in a substation, whereas it decreases on the 77-kV bus at the primary, under light-load conditions at night. These observations based on the actual measurement suggest that the increase of 5th harmonic voltage on the 6.6-kV bus at night is due to “harmonic propagation” as a result of series and/or parallel harmonic resonance between line inductors and shunt capacitors for power-factor correction installed on the distribution system. This implies that not only harmonic compensation, but also harmonic damping, is a viable and effective way to solve harmonic pollution in power distribution systems. Hence, electric power utilities should have responsibility for actively damping harmonic propagation throughout power distribution systems. Individual consumers and end-users are responsible for keeping the current harmonics produced by their own equipment within specified limits. Both problems of harmonic elimination and harmonic damping are exhaustively discussed and analyzed in this book.

Table 1-2. THD in voltage and 5th harmonic voltage in a medium-voltage power distribution system

	6 kV			
	Residential area		Commercial area	
	THD	5th harmonic	THD	5th harmonic
Maximum	3.5 %	3.4 %	4.6 %	4.3 %
Minimum	3.0 %	2.9 %	2.1 %	1.2 %

1.4. IDENTIFIED AND UNIDENTIFIED HARMONIC-PRODUCING LOADS

Nonlinear loads drawing nonsinusoidal currents from three-phase, sinusoidal, balanced voltages are classified as identified and unidentified loads. High-power diode or thyristor rectifiers, cycloconverters, and arc furnaces are typically characterized as identified harmonic-producing loads, because electric power utilities identify the individual nonlinear loads installed by high-power consumers on power distribution systems in many cases. Each of these loads generates a large amount of harmonic current. The utilities can determine the point of common coupling (PCC) of high-power consumers who install their own harmonic-producing loads on power distribution systems. Moreover, they can determine the amount of harmonic current injected from an individual consumer.

A “single” low-power diode rectifier produces a negligible amount of harmonic current compared with the system total current. However, multiple low-power diode rectifiers can inject a significant amount of harmonics into the power distribution system. A low-power diode rectifier used as a utility interface in an electric appliance is typically considered as an unidentified harmonic-producing load.

So far, less attention has been paid to unidentified loads than identified loads. Harmonic regulations or guidelines such as IEEE 519-1992 are currently applied, with penalties on a voluntary basis, to keep current and voltage harmonic levels in check. The final goal of the regulations or guidelines is to promote better practices in both power systems and equipment design at minimum social cost.

Table 1-3 shows an analogy in unidentified and identified sources between harmonic pollution and air pollution. The efforts by researchers and engineers in the automobile industry to comply with the Clean Air Act Amendments of 1970 led to success in suppressing CO, HC, and NO_x contained in automobile exhaust. As a result, the reduction achieved was 90% when gasoline-fueled passenger cars in the 1990s are compared with the same class of cars at the beginning of the 1970s. Moreover, state-of-the-art technology has brought much more reductions in the exhaust of modern gasoline-fueled passenger cars. It is interesting that the development of the automobile industry, along with the proliferation of cars, has made it

Table 1-3. Analogy between harmonic pollution and air pollution

Sources	Harmonic pollution	Air pollution
Unidentified	<ul style="list-style-type: none"> • TV sets and personal computers • Inverter-based home appliances such as adjustable-speed heat pumps for air conditioning • Adjustable-speed motor drives 	<ul style="list-style-type: none"> • Gasoline-fueled vehicles • Diesel-fueled vehicles
Identified	<ul style="list-style-type: none"> • Bulk diode/thyristor rectifiers • Cycloconverters • Arc furnaces 	<ul style="list-style-type: none"> • Chemical plants • Coal and oil steam power plants

possible to absorb the increased cost related to the reduction of harmful components in exhaust emitted by gasoline-fueled vehicles [24].

Harmonic regulations or guidelines are effective in overcoming “harmonic pollution.” Customers pay for the cost of high performance, high efficiency, energy savings, reliability, and compactness brought by power electronics technology. However, they are unwilling to pay for the cost of solving the harmonic pollution generated by power electronics equipment unless regulations or guidelines are enacted. It is expected that the continuous efforts by power electronics researchers and engineers will make it possible to absorb the increased cost for solving the harmonic pollution.

1.5. HARMONIC CURRENT AND VOLTAGE SOURCES

In most cases, either a harmonic current source or a harmonic voltage source can represent a harmonic-producing load, from a practical point of view.

Figure 1-1(a) shows a three-phase diode rectifier with an inductive load. Note that a dc inductor L_{dc} is directly connected in series to the dc side of the diode rectifier. Here, L_{ac} is the ac inductor existing downstream of the point of common coupling (PCC). This inductor may be connected to the ac side of the diode rectifier, and/or the leakage inductance of a transformer may be installed at the ac side of the rectifier for voltage matching and/or electrical isolation. Note that this transformer is disregarded in Fig. 1-1(a). On the other hand, L_S represents a simplified equivalent inductance of the power system existing upstream of the PCC. In most cases, the inductance value of L_S is much smaller than that of L_{ac} . In other words, the short-circuit capacity upstream of the PCC is much larger than that downstream of the PCC, so that L_S is very small and might be neglected.

Since the inductance value of L_{dc} is larger than that of the ac inductor L_{ac} in many cases, the waveform of i_{Sh} is independent of L_{ac} . This allows us to treat the rectifier as a harmonic *current* source when attention is paid to harmonic voltage and current, as shown in Fig. 1-1(b). Strictly speaking, the current waveform is slightly influenced by the ac inductance because of the so-called “current overlap effect” as long as L_{ac} is not equal to zero. Note that the system inductor L_S plays an essential role in producing the harmonic voltage at the PCC, whereas the ac inductor L_{ac} makes no contribution.

Figure 1-1(c) shows a simplified circuit derived from Fig. 1-1(b), where \dot{I}_{Shn} is not an instantaneous current but an rms current at the n th-order harmonic frequency and, moreover, L_{ac} is hidden in the harmonic current source. The product of the system reactance X_{Sn} (at n th order of harmonic frequency) and the harmonic current \dot{I}_{Shn} gives the rms value of the n th-order harmonic voltage \dot{V}_{Shn} appearing at the PCC.

Figure 1-2(a) shows a three-phase diode rectifier with a capacitive load. Unlike Fig. 1-1(a), a dc capacitor C_{dc} is directly connected in parallel to the dc side of the diode rectifier. As a result, the diode rectifier, seen from the ac side, can be characterized as a harmonic voltage source v_h , as shown in Fig. 1-2(b). Note that it would

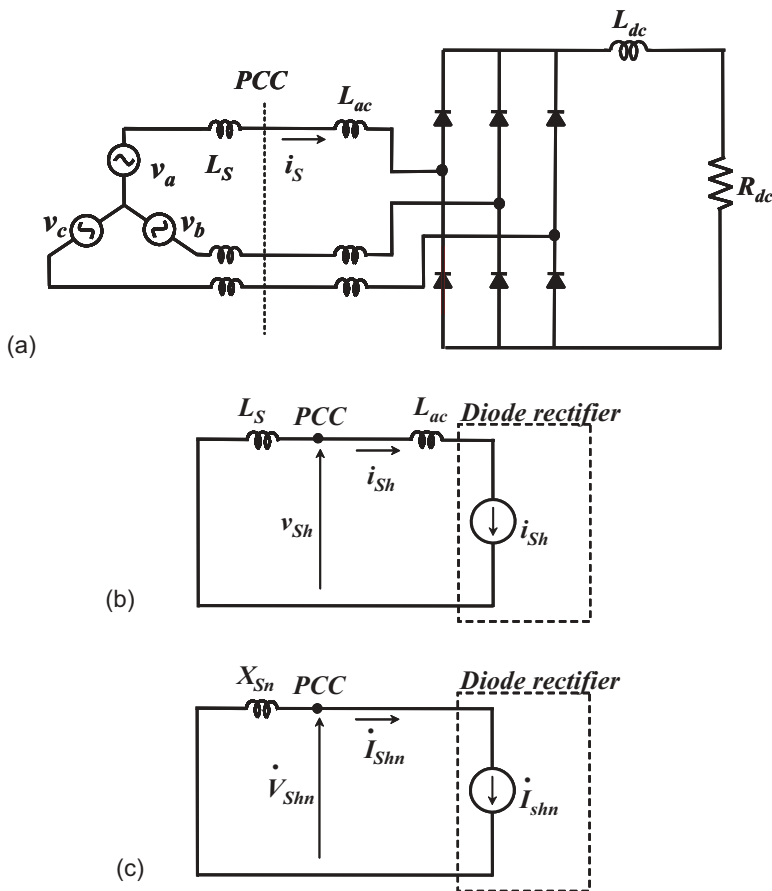

Figure 1-1. A three-phase diode rectifier with an inductive load. (a) Power circuit, (b) equivalent circuit for harmonic voltage and current on a per-phase basis, (c) simplified circuit.

be difficult to describe the waveform of v_h because i_S is a discontinuous waveform and, moreover, the conducting interval of each diode depends on L_{ac} among other circuit parameters. The reason why the rectifier can be considered as harmonic voltage source is that the harmonic impedance downstream of the ac terminals of the rectifier is much smaller than that upstream of the ac terminals. This means that the supply harmonic current i_{Sh} is strongly influenced by the ac inductance L_{ac} . Unless the ac inductance exists, the rectifier would draw a distorted pulse current with an extremely high peak value from the ac mains because only the system inductor L_S , which is too small in many cases, would limit the harmonic current. Invoking the so-called “equivalent transformation between a voltage source and a current source” allows us to obtain Fig. 1-2(c) from Fig. 1-2(b). Here, I_{Shn} and V_{hn} are an

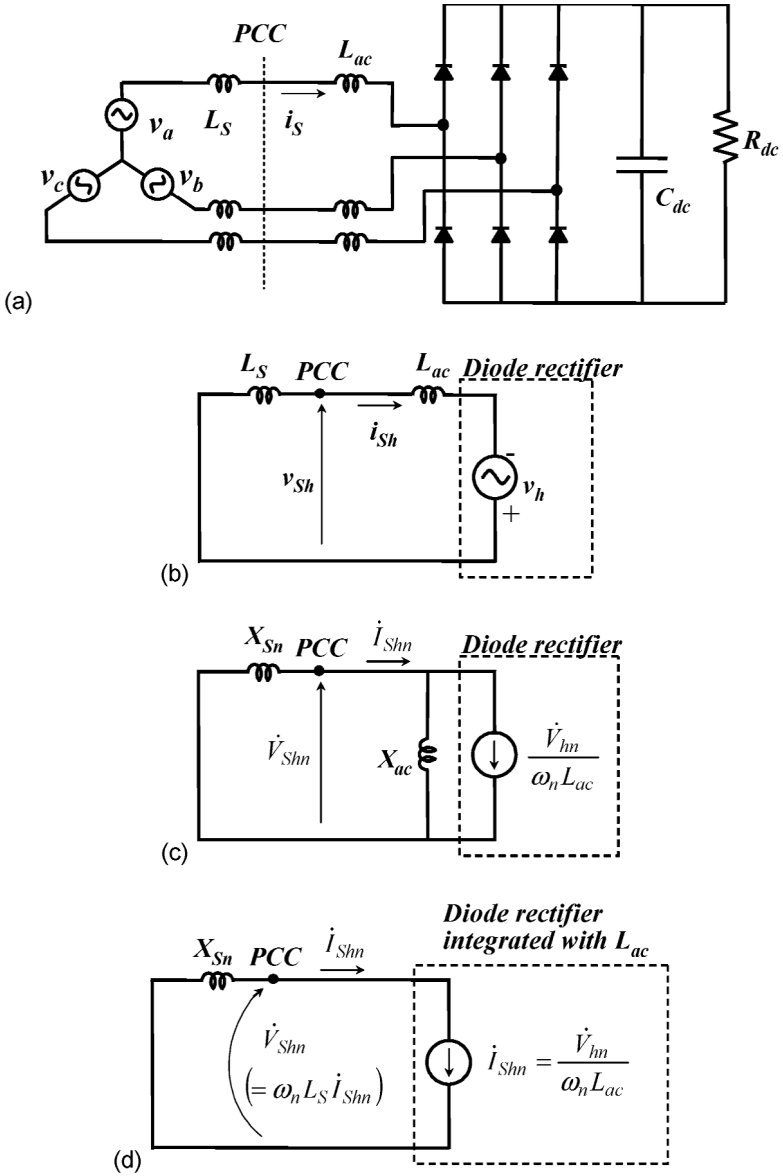

Figure 1-2. A three-phase diode rectifier with a capacitive load. (a) Power circuit, (b) equivalent circuit for harmonic voltage and current on a per-phase basis, (c) equivalent transformation between a voltage source and current source, (d) simplified circuit with the assumption that $L_S \ll L_{ac}$.

rms current and an rms voltage at the n -th order harmonic frequency, respectively. Assuming that the inductance value of L_{ac} is much larger than that of L_S allows us to eliminate L_{ac} from Fig. 1-2(c). This results in a simplified circuit, as shown in Fig. 1-2(d). It is quite interesting that the diode rectifier including the ac inductance L_{ac} is not a harmonic voltage source but a harmonic current source as long as it is seen downstream of the PCC, although the diode rectifier itself is characterized as a harmonic voltage source.

1.6. BASIC PRINCIPLES OF HARMONIC COMPENSATION

Figure 1-3 shows a basic circuit configuration of a shunt active filter in a three-phase, three-wire system. This is one of the most fundamental active filters intended for harmonic-current compensation of a nonlinear load. For the sake of simplicity, no system inductor exists upstream of the point of common coupling. This shunt active filter equipped with a current minor loop is controlled to draw the compensating current i_C from the ac power source, so that it cancels the harmonic current contained in the load current i_L .

Figure 1-4 depicts voltage and current waveforms of the ac power source v_a , the source current i_{Sa} , the load current i_{La} , and the compensating current i_{Ca} in the a-phase, under the following assumptions. The smoothing reactor L_{dc} in the dc side of the rectifier is large enough to keep constant the dc current, the active filter operates as an ideal controllable current source, and the ac inductor L_{ac} is equal to zero. The

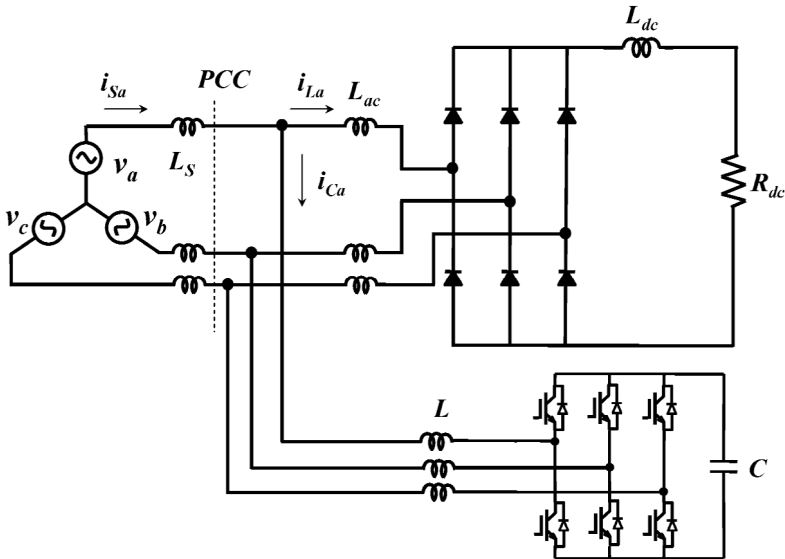

Figure 1-3. System configuration of a stand-alone shunt active filter.

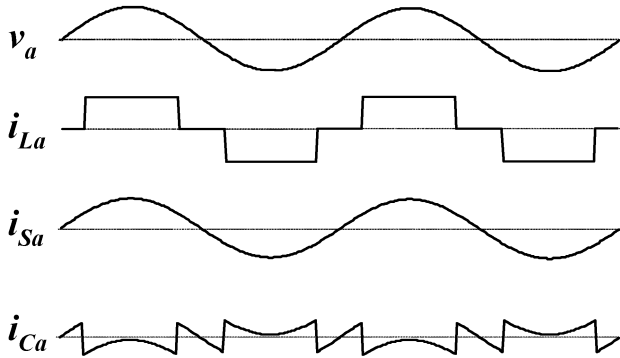

Figure 1-4. Waveforms of voltage and current in Fig. 1-3.

shunt active filter should be applied to a nonlinear load that can be considered as a harmonic current source, such as a diode/thyristor rectifier with an inductive load, an arc furnace, and so on. At present, a voltage-source PWM converter is generally preferred as the power circuit of the active filter, instead of a current-source PWM converter. A main reason is that the insulated-gate bipolar transistor (IGBT), which is one of the most popular power switching devices, is integrated with a free-wheeling diode, so that such an IGBT is much more cost-effective in constructing the voltage-source PWM converter than the current-source PWM converter. Another reason is that the dc capacitor indispensable for the voltage-source PWM converter is more compact and less heavy than the dc inductor for the current-source PWM inverter.

In addition to harmonic-current compensation, the shunt active filter has the capability of reactive-power compensation. However, adding this function to the shunt active filter brings an increase in current rating to the voltage-source PWM converter. Chapter 4 describes the shunt active filter in detail.

Figure 1-5 shows a basic circuit configuration of a series active filter in three-phase, three-wire systems. The series active filter consists of either a three-phase voltage-source PWM converter or three single-phase voltage-source PWM converters, and it is connected in series with the power lines through either a three-phase transformer or three single-phase transformers. Unlike the shunt active filter, the series active filter acts as a controllable *voltage* source and, therefore, the voltage-source PWM converter has no current minor loop. This makes the series active filter suitable for compensation of a harmonic voltage source such as a three-phase diode rectifier with a capacitive load.

Figure 1-6 depicts voltage and current waveforms of the mains voltage v_a , the supply current i_{Sa} , the load voltage v_{La} (the voltage at the ac side of the rectifier), and the compensating voltage v_{Ca} in the a-phase. Here, the following assumptions are made: the capacitor C_{dc} in the dc side of the rectifier is larger enough to keep constant dc voltage, the active filter operates as an ideal controllable voltage source, and the ac inductor L_{ac} is equal to zero. In a real system, the series active filter would not work properly if no ac inductor existed. In other words, an ac inductor is

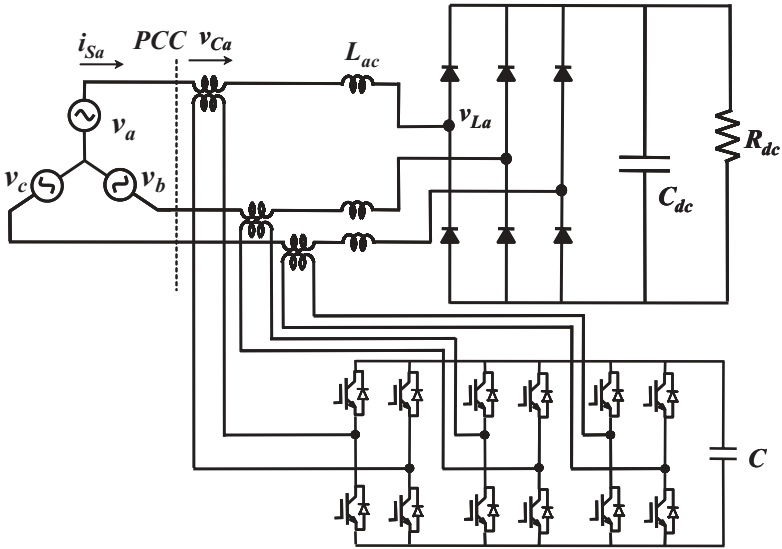

Figure 1-5. System configuration of a stand-alone series active filter.

essential to achieve proper operation, even if the series active filter is assumed to be ideal. The reason is that the ac inductor plays an important role in supporting voltage difference between source voltage v_s and the sum of the compensating voltage v_C and the load voltage v_L . Since the supply current is identical to the input current of the rectifier, it is changed from a distorted discontinuous waveform to a sinusoidal, continuous waveform as a result of achieving harmonic-voltage compensation. This means that the conducting interval of each diode becomes 180° .

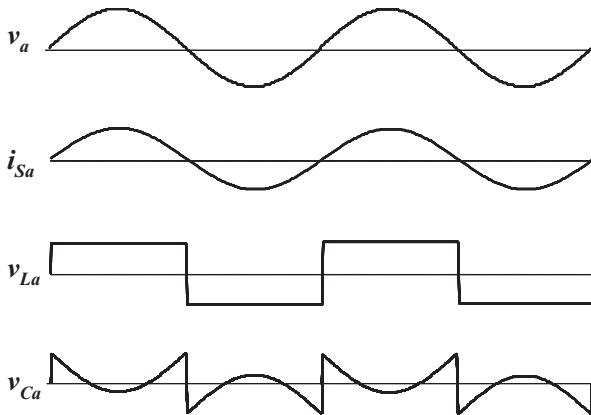

Figure 1-6. Waveforms of currents and voltages in Fig. 1-5.

When the series active filter is intended only for harmonic compensation, the compensating voltage v_C has no fundamental-frequency component. The dc voltage of the diode rectifier can be regulated by intentionally controlling the fundamental-frequency component of the compensating voltage.

Table 1.4 summarizes comparisons between the shunt and series active filters. Note that the series active filter has a “dual” relationship in each item with respect to the shunt active filter. Chapter 5 presents discussions of the series active filter.

Considering that the distribution system is based on the concept that a voltage source is delivered to the final user, it is common to consider it as an almost ideal voltage source. Therefore, in most cases where the source impedance is relatively small, the voltage waveform is considered purely sinusoidal even when the load is nonlinear and the current is distorted. In this case, the basic compensation principle is based on a shunt active filter, as shown in Fig. 1-3.

1.7. BASIC PRINCIPLE OF POWER FLOW CONTROL

This book is mainly dedicated to the problems related to power quality, for which harmonic elimination and damping are two of the major concerns. In fact, these points are more closely related to the Custom Power concept introduced in [25], which is normally applied to low-voltage systems or distribution systems. Chapters 4, 5, and 6 will present shunt, series, and combined shunt–series active filters. Moreover, it will be seen that the use of the p - q Theory makes it easy to perform reactive-power compensation. On the other hand, the concept of FACTS (Flexible AC Transmission Systems), as introduced in [20], has the main objective of improving controllability of power transmission systems that are operated at higher voltage and power level than power distribution systems can be. This improvement of controllability actually means a fast, continuous, and dynamic reactive-power control, as well as power-flow control or active-power control. Reactive-power control is used for power-factor correction, voltage regulation, and stability im-

Table 1.4. Comparisons between shunt and series active filters

	Shunt Active Filter	Series Active Filter
Circuit configuration	Fig. 1-3	Fig. 1-5
Power circuit	Voltage-source PWM converter with current minor loop	Voltage-source PWM converter without current minor loop
Operation	Current source: i_C	Voltage source: v_C
Suitable nonlinear load	Diode / thyristor rectifier with inductive load	Diode rectifier with capacitive load
Additional function	Reactive-power compensation	ac voltage regulation