

01 May 2001

## Integration of a StatCom and Battery Energy Storage

Zhiping Yang

Shen Chen

Lin Zhang

Stan Atcitty

*et. al.* For a complete list of authors, see [https://scholarsmine.mst.edu/ele\\_comeng\\_facwork/679](https://scholarsmine.mst.edu/ele_comeng_facwork/679)

Follow this and additional works at: [https://scholarsmine.mst.edu/ele\\_comeng\\_facwork](https://scholarsmine.mst.edu/ele_comeng_facwork)



Part of the [Electrical and Computer Engineering Commons](#)

---

### Recommended Citation

Z. Yang et al., "Integration of a StatCom and Battery Energy Storage," *IEEE Transactions on Power Systems*, vol. 16, no. 2, pp. 254-260, Institute of Electrical and Electronics Engineers (IEEE), May 2001. The definitive version is available at <https://doi.org/10.1109/59.918295>

This Article - Journal is brought to you for free and open access by Scholars' Mine. It has been accepted for inclusion in Electrical and Computer Engineering Faculty Research & Creative Works by an authorized administrator of Scholars' Mine. This work is protected by U. S. Copyright Law. Unauthorized use including reproduction for redistribution requires the permission of the copyright holder. For more information, please contact [scholarsmine@mst.edu](mailto:scholarsmine@mst.edu).

# Integration of a StatCom and Battery Energy Storage

Z. Yang, *Student Member, IEEE*, C. Shen, *Member, IEEE*, L. Zhang, *Student Member, IEEE*,  
M. L. Crow, *Senior Member, IEEE*, and S. Atcitty, *Member, IEEE*

**Abstract**—The integration of an energy storage system, such as battery energy storage (BESS), into a FACTS device can provide dynamic decentralized active power capabilities and much needed flexibility for mitigating transmission level power flow problems. This paper will introduce an integrated StatCom/BESS for the improvement of dynamic and transient stability and transmission capability; compare the performance of the different FACTS/BESS combinations, and provide experimental verification of the proposed controls on a scaled StatCom/BESS system.

**Index Terms**—Battery energy storage, control system synthesis, FACTS, power system dynamic stability.

## I. INTRODUCTION

**I**N BULK power transmission systems, power electronics based controllers are frequently called Flexible AC Transmission System (FACTS) devices. By facilitating bulk power transfers, these flexible networks help delay or minimize the need to build more transmission lines and power plants and enable neighboring utilities and regions to economically and reliably exchange power. Although relatively new, the stature of FACTS devices within the bulk power system will continually increase as power electronic technologies improve and the restructured electric utility industry moves steadily toward a more competitive posture in which power is bought and sold as a commodity. In decentralized control of transmission systems, FACTS devices offer increased flexibility. As the vertically integrated utility structure is phased out, centralized control of the bulk power system will no longer be possible. Transmission providers will be forced to seek means of local control to address a number of potential problems such as uneven power flow through the system (loop flows), transient and dynamic instability, subsynchronous oscillations, and dynamic overvoltages and undervoltages. Several FACTS topologies have been proposed to mitigate these potential problems, but transmission service providers have been reluctant to install them, usually due to cost and lack of systematic control. The integration of energy storage systems (ESS) into FACTS devices, however, may lead to a more economical and/or flexible transmission controller. In many applications (such as those described in this paper), the energy storage device is small and is only required to supply power for a short period of time. In this case, the cost of the FACTS electronics system dominates the cost of

the ESS [1]. Thus, the enhanced performance of the combined FACTS/ESS will have greater appeal to transmission service providers.

While the FACTS/ESS combination has been proposed in theory [2], the development of FACTS/ESS combination has lagged far behind that of FACTS alone. Considerable attention has been given to developing control strategies for a variety of FACTS devices, including the Static Synchronous Compensator (StatCom), the Static Synchronous Series Compensator (SSSC), and the Unified Power Flow Controller (UPFC), to mitigate a wide range of potential bulk power transmission problems. However, a comparable field of knowledge for FACTS/ESS control is sparse. In addition, numerous complex models for StatCom control have been proposed, but have not been experimentally verified. Therefore, this paper will discuss the enhancement of power transmission system operation by integrating a Battery Energy Storage System (BESS) into a StatCom which is one of the common FACTS devices. Specifically, this paper will

- propose control strategies for voltage control, dynamic stability, and transmission capability improvement,
- compare simulation and experimental results of an integrated StatCom/BESS system, and
- compare the performance of different FACTS/BESS combinations.

This paper also lays the foundation for increased operational flexibility by integrating energy storage with other FACTS topologies such as the SSSC and the UPFC.

## II. INTEGRATION OF BATTERY ENERGY STORAGE WITH A STATCOM

The static synchronous compensator, or StatCom, is a shunt-connected device. The StatCom does not employ capacitor or reactor banks to produce reactive power as does the Static Var Compensator (SVC). In the StatCom, the capacitor bank is used to maintain a constant DC voltage for the voltage-source converter operation. Common StatComs may vary from six-pulse topologies up to forty-eight-pulse topologies that consist of eight six-pulse converters operated from a common dc link capacitor [4], [5]. The displacement angle between two consecutive six-pulse converters in a multipulse converter configuration is  $2\pi/6m$  where  $m$  is the total number of six-pulse converters. Phase adjustments between the 6-pulse converter groups are accomplished by the use of appropriate magnetic circuits. Using this topology, the angle of the StatCom voltage can be varied with respect to the AC system voltage. By controlling the angle, the StatCom can inject capacitive or inductive current at the AC system bus.

Manuscript received April 3, 2000. This work was supported by the National Science Foundation under Awards ECS-9257208, Sandia National Laboratories under BD-0071D, and the University of Missouri-Rolla Intelligent Systems Center.

Z. Yang, C. Shen, L. Zhang and M. L. Crow are with Electrical and Computer Engineering, University of Missouri-Rolla, Rolla, MO 65409-0040.

S. Atcitty is with Power Electronics and Custom Controllers, Sandia National Laboratories, Albuquerque, NM 87185-0537.

Publisher Item Identifier S 0885-8950(01)03798-1.

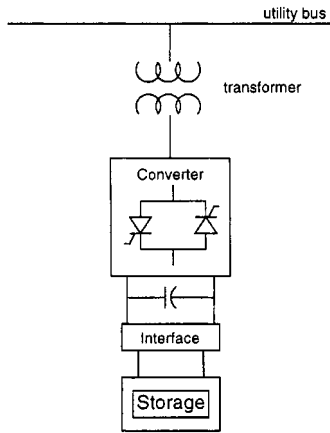

Fig. 1. Integrated StatCom with energy storage.

Although the ability of a StatCom to improve power system performance has been well accepted, very little information regarding its dynamic control has been published [6]. The StatCom is best suited for voltage control since it may rapidly inject or absorb reactive power to stabilize voltage excursions [3], [4], [6], [7] and has been shown to perform very well in actual operation [5]. Several prototype StatCom installations are currently in operation [5], [8]. The ability of the StatCom to maintain a pre-set voltage magnitude with reactive power compensation has also been shown to improve transient stability [6] and subsynchronous oscillation damping [9]–[11]. However, a combined StatCom/ESS system can provide better dynamic performance than a stand-alone StatCom. The fast, independent active and reactive power support provided by an ESS coupled to a StatCom can significantly enhance the flexibility and control of transmission and distribution systems. The configuration of an integrated StatCom/ESS is shown in Fig. 1.

The traditional StatCom (with no energy storage) has only two possible steady-state operating modes: inductive (lagging) and capacitive (leading). Although both the traditional StatCom output voltage magnitude and phase angle can be controlled, they cannot be independently adjusted in steady state since the StatCom has no significant active power capability. Thus it is not possible to significantly impact both active and reactive power simultaneously. For the StatCom/ESS, the number of steady state operation modes is extended to all four quadrants. These modes are inductive with DC charge, inductive with DC discharge, capacitive with DC charge, and capacitive with DC discharge. Due to the nature of ESS, the StatCom/ESS cannot be operated infinitely in one of the four modes (i.e., the battery cannot continuously discharge); therefore these modes represent quasisteady-state operation. However, depending on the energy output of the battery or other ESS, the discharge/charge profile is typically sufficient to provide enough energy to stabilize the power system and maintain operation until other long-term energy sources may be brought on-line.

Fig. 2 shows the steady state operational characteristics of the StatCom/BESS output. Note that in steady state, the output voltage of the traditional StatCom is in one dimension only, and must lie along the dashed line, whereas the output voltage

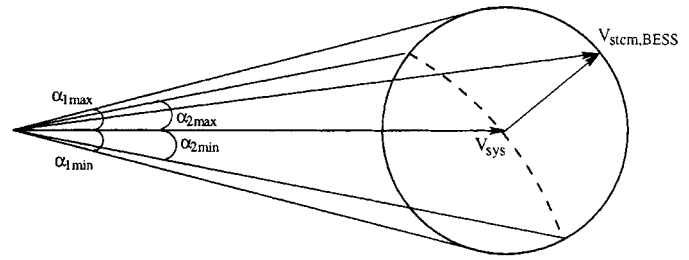

Fig. 2. StatCom/BESS voltage characteristics.

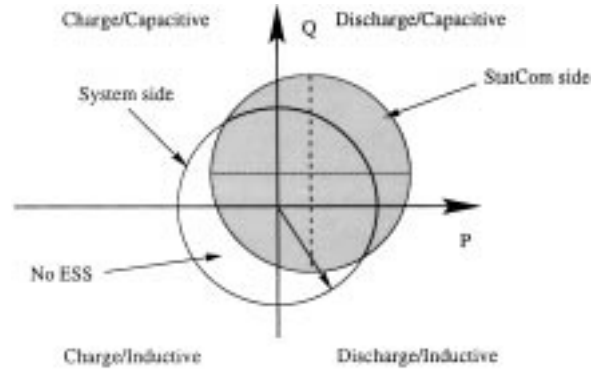

Fig. 3. StatCom/BESS output power characteristics.

of a StatCom/BESS can take on any value within the circle. This gives the StatCom/BESS an additional degree of operating freedom that provides the enhanced performance and impact. The dashed line of the traditional StatCom operational curve separates the StatCom/BESS operating region into two regions. The upper right region represents the BESS discharge area and the lower left region is the charging area. The angles  $\alpha_{1\max}$  and  $\alpha_{1\min}$  are the maximum and minimum output voltage angles of the StatCom/BESS. The angles  $\alpha_{2\max}$  and  $\alpha_{2\min}$  are the maximum and minimum output voltage angles of the traditional StatCom. These angles are dependent on the system voltage, equivalent impedance and the maximum current limit of the StatCom/BESS. The maximum current limit of the StatCom/BESS is determined by the maximum transformer current, the maximum device current, and the maximum output current of the BESS.

Fig. 3 illustrates the StatCom side and the system side active and reactive power characteristics under constant terminal voltage. The StatCom side is the converter side of the transformer shown in Fig. 1. The two circles of radius  $V_{sys}I_{\max}$  represent the possible output power of the StatCom side (shaded region) and the system side. Note that the center of the StatCom circle is shifted from the origin by  $I_{\max}^2 Z$ , where  $Z$  represents the equivalent impedance of the StatCom and transformer. The dashed lines represent the possible output power of the traditional StatCom. Note that on the system side of the traditional StatCom (the dashed arc), the active power is always negative to indicate that the StatCom will always draw active power from the system to compensate for any losses. Under ideal conditions, the StatCom/BESS can be operated anywhere within the circular region.

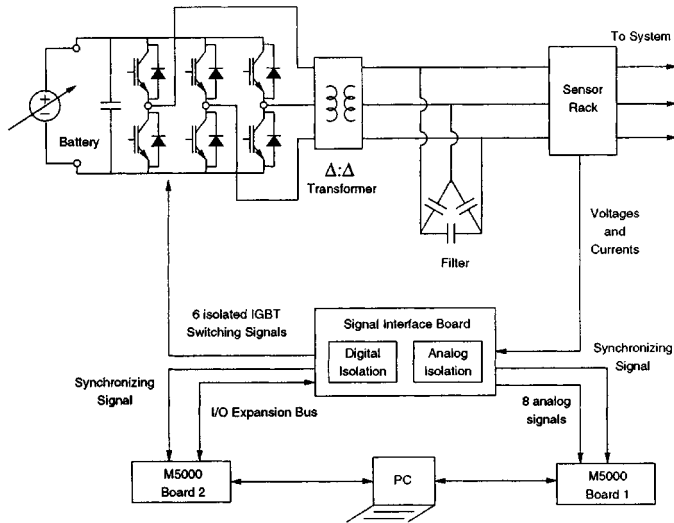

Fig. 4. Experimental StatCom/BESS.

### III. STATCOM/BESS CONTROL

The control objective of the StatCom/BESS is to maintain system performance according to some pre-set or user defined scheme. The control objective may be voltage control, power flow control for oscillation damping, or transient stability improvement. A control scheme for active and reactive power flow control has been implemented on a scaled laboratory StatCom/BESS system.

#### A. Experimental StatCom/BESS System

A StatCom hardware set-up has been constructed at the University of Missouri-Rolla. With funding from Sandia National Laboratories Energy Storage Systems Department, the experimental StatCom was interfaced with a battery set that consists of 34 VLRA super-gel batteries in two strings supplying 204 V dc. A data acquisition system was constructed to monitor the battery voltage and string currents. A signal interface board provides the digital and analog isolation and converts the current signals into voltage signals and filters the high-frequency noise. A bank of three-phase 150  $\mu$ F capacitors is used to filter the line-line StatCom/BESS voltage output. The monitoring and control system for the integrated StatCom/BESS system consists of two M5000 boards; one for data acquisition and pre-processing and the other for PWM signal generation. The A/D board measures the system frequency within 0.01 Hz. It is also used to calculate various state variables such as  $P$ ,  $Q$ ,  $V_{\text{rms}}$ , and  $I_{\text{rms}}$  to export to the PC for the control algorithm. It also provides error detection/correction and digital filtering. The system controller is fully programmable so that new controls can be implemented rapidly. The StatCom/BESS is rated at 3 kVA. The experimental set-up is shown in Fig. 4 and described in greater detail in [12].

#### B. Transmission Capacity Control

The development of transmission capacity control is based on the assumption of pulse width modulated (PWM) switching using triangle modulation, and a relatively high switching frequency (63 switching cycles per period of the fundamental).

Current trends in the development of the family of high-power, fast-switched IGBTs support the future use of PWM control for transmission level applications. In the  $dq$  system reference, the dynamic StatCom/BESS can be modeled as:

$$\begin{aligned} \frac{d}{dt} \begin{bmatrix} i_d \\ i_q \\ V_{\text{dc}} \end{bmatrix} &= \omega_s \begin{bmatrix} -\frac{R'_s}{L'_s} & \frac{\omega}{\omega_s} & 0 \\ \frac{\omega}{\omega_s} & -\frac{R'_s}{L'_s} & 0 \\ 0 & 0 & -\frac{1}{C'} \left( \frac{R'_b R'_{\text{dc}}}{R'_{\text{dc}} + R'_b} \right) \end{bmatrix} \begin{bmatrix} i_d \\ i_q \\ V_{\text{dc}} \end{bmatrix} \\ &+ \omega_s \begin{bmatrix} \frac{V_{\text{dc}}}{L'_s} k \cos(\alpha + \theta) \\ \frac{V_{\text{dc}}}{L'_s} k \sin(\alpha + \theta) \\ -\frac{i_d}{C'} k \cos(\alpha + \theta) - \frac{i_q}{C'} k \sin(\alpha + \theta) \end{bmatrix} \\ &- \omega_s \begin{bmatrix} \frac{V_s \cos \theta}{L'_s} \\ \frac{V_s \sin \theta}{L'_s} \\ \frac{-V_b}{R'_b C'} \end{bmatrix} \end{aligned} \quad (1)$$

where

- $i_d$  and  $i_q$  are the injected per unit  $dq$  StatCom currents,
- $V_{\text{dc}}$  is the per unit voltage across the dc capacitor  $C'$ ,
- $R'_s$  and  $L'_s$  represent the StatCom transformer losses,
- $k$  and  $\alpha$  are the PWM modulation gain and angle respectively,
- $V_b$  is the per unit battery voltage,
- $R'_b$  represents the battery losses,
- $R'_{\text{dc}}$  represents the switching losses, and
- $V_s \angle \theta$  is the per unit system side (ac) bus voltage.

The controller provides an active and reactive power command to achieve the desired system response. The controller converts the commanded powers into PWM switching commands for the StatCom to regulate the modulation gain and angle. For optimal control of transmission capacity, it is desired to have a controller that can achieve independent active and reactive power response. To accomplish this goal, a decoupled PI controller is proposed which can produce the desired switching commands from independent active and reactive power commands.

Since control is defined for a particular StatCom/BESS, the system bus voltage angle  $\theta$  may be taken to be identically zero in the control without loss of generality. Therefore the StatCom/BESS active power  $P$  and reactive power  $Q$  on the power system side can be calculated in the reference frame coordinates as

$$P = V_s i_d, \quad Q = -V_s i_q \quad (2)$$

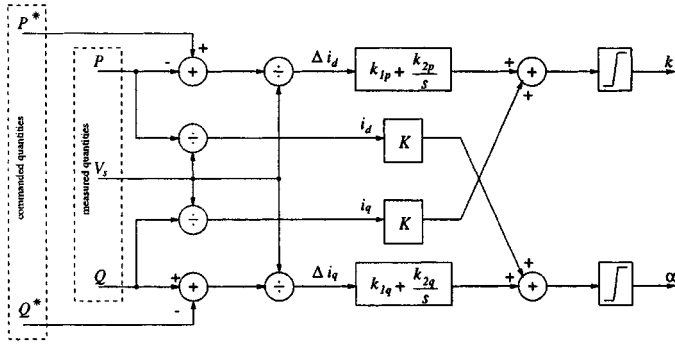

Fig. 5. Decoupled PQ control.

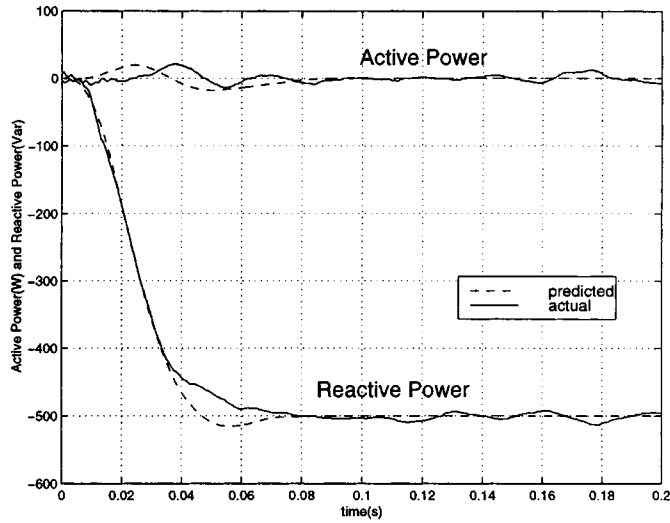

Fig. 6. Step change in reactive power.

where realizing decoupled active and reactive power can be achieved through decoupled  $i_d$  and  $i_q$  control.

At equilibrium, there is no active power exchange between the StatCom and battery, thus the first two rows of equation (1) may be linearized to obtain:

$$\frac{d}{dt} \begin{bmatrix} \Delta i_d \\ \Delta i_q \end{bmatrix} = \omega_0 \begin{bmatrix} -\frac{R'_s}{L'_s} & 0 \\ 0 & -\frac{R'_s}{L'_s} \end{bmatrix} \begin{bmatrix} \Delta i_d \\ \Delta i_q \end{bmatrix} + \begin{bmatrix} x_1 \\ x_2 \end{bmatrix} \quad (3)$$

$$\begin{bmatrix} x_1 \\ x_2 \end{bmatrix} = \begin{bmatrix} \omega_0 \Delta i_q + \frac{k_0}{L'_s} \Delta V_{dc} + \frac{V_{dc0}}{L'_s} \Delta k_0 \\ \frac{V_{dc0} k_0}{L'_s} \Delta \alpha - \omega_0 \Delta i_d \end{bmatrix} \quad (4)$$

where  $[x_1 \ x_2]^T$  is the control variable vector. In the StatCom/BESS system, the dc voltage  $V_{dc}$  is held nearly constant by the battery, therefore the incremental change  $\Delta V_{dc}$  is negligible. By combining equations (2)–(4), a decoupled PI local controller for producing a PWM modulation index  $k$  and angle  $\alpha$  from a desired  $P^*$  and  $Q^*$  command can be developed as shown in Fig. 5.

The effectiveness of this control is illustrated in Figs. 6 and 7, where the active and reactive powers are independently commanded to make step changes. The results of the simulated control are shown concurrently with the experimental results,

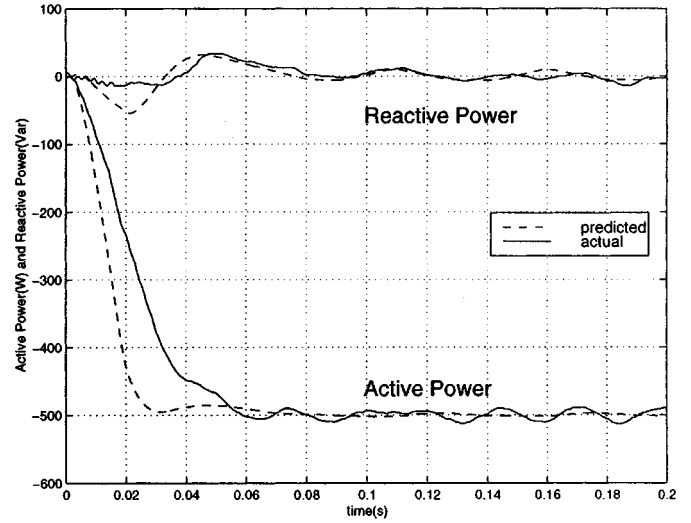

Fig. 7. Step change in active power.

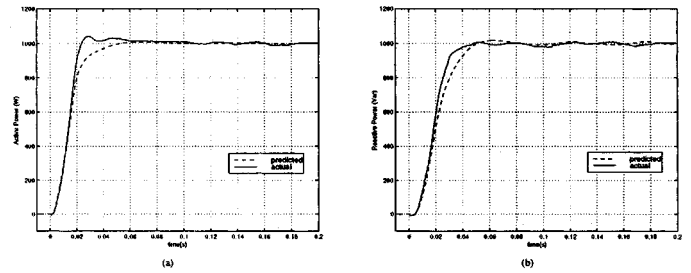

Fig. 8. Simultaneous step change of active and reactive power from 0 to 1 kW and 1 kVar (respectively).

where the solid lines indicate the measured power dynamics and the dashed lines indicate the predicted dynamics. The simulation results were obtained from a detailed model of the laboratory system built in the software package PSCAD. The simulation model used the measured values of the laboratory parameters of the StatCom/BESS system (transformer reactances, filter capacitances, etc.).

In Fig. 6, the reactive power is commanded to change from 0 to  $-0.5$  kVar (a step change of 0.17 per unit) while holding the active power at zero. Similarly, Fig. 7 shows a 0.17 per unit step change in active power while holding the reactive power at zero. The corresponding change in current is 1.26 A. In both cases, the independent nature of the control is evident, since a commanded change in one power causes only a small response in the other. Both the active and reactive powers achieved their target values within 0.1 seconds, which is the desired response time. Also the simulated response predicts the experimental behavior very well. The slight oscillation in both experimental responses is due to the imbalance of the ac system voltages. The local control was developed based on the assumption of a three-phase balanced system. However, even in the case of system imbalance (which occurs often in practice), the controller responds well. The slight responses in the powers being held at zero is due to the linearized control process, since the active and reactive powers are not truly fully decoupled in the nonlinear system.

The controller was also tested on larger commanded changes. Figs. 8 and 9 show the response of the StatCom/BESS

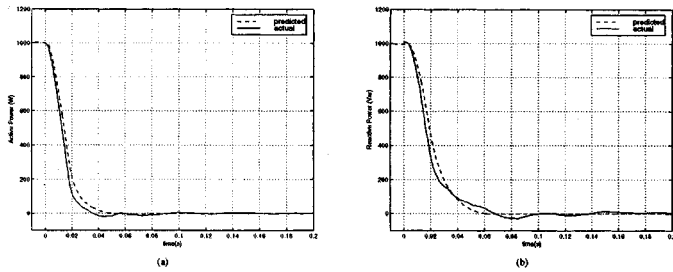

Fig. 9. Simultaneous step change of active and reactive power to 0.

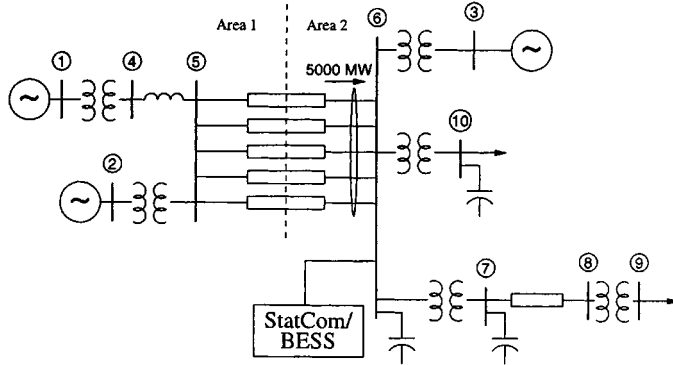

Fig. 10. Example system for comparison of controls.

to changes of over 50% of the rated value of the StatCom/BESS, where a step change of 1 kW and 1 kVar is simultaneously commanded. The corresponding change in current is 3.6 A. In all cases, the controller has achieved the target in under 0.1 seconds and with minimal overshoot or oscillation. This control is well-suited for short term transmission capacity control to avoid line overloads and to relieve transmission congestion. The close correspondence of the experimental results with the simulated results indicate that the developed StatCom/BESS model is well suited for designing system controls.

### C. Control for Oscillation Damping and Voltage Control

The independent control of both active and reactive power of the StatCom/BESS system make it an ideal candidate for many types of power system applications. Possible applications of the StatCom/BESS include voltage and transmission capacity control, frequency regulation, oscillation damping, and dynamic stability improvement. These requirements may change based on the size and placement of the StatCom/BESS within the power system. In this section, two applications of the StatCom/BESS are presented: voltage control and oscillation damping. The system under consideration is the system shown in Fig. 10, where the system data is the same as in [13]. At 0.01 seconds, one of the parallel transmission lines between buses 5 and 6 is opened. This results in a system wide drop in voltage and causes a low frequency interarea power oscillation between the two areas. The interarea oscillation exhibits a lightly-damped mode at 1.4 Hz.

For an even comparison between controllers, the same control approach was applied for both the StatCom and the StatCom/BESS system. The active power flow was controlled

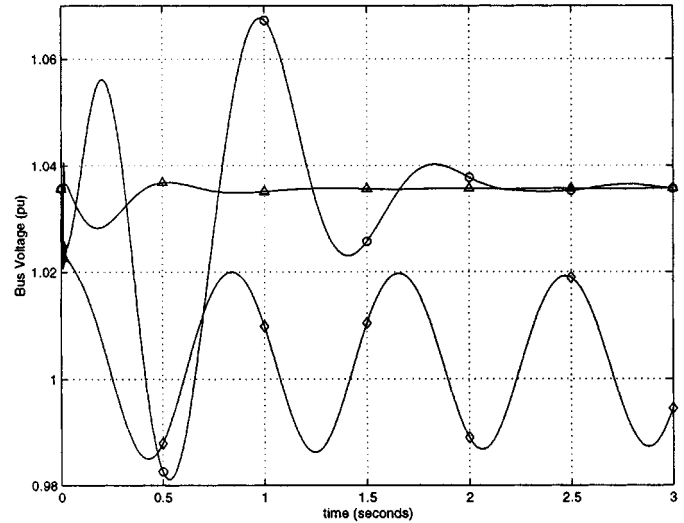

Fig. 11. Voltage at Bus 6 ( $\diamond$ —no control,  $\circ$ —StatCom,  $\triangle$ —StatCom/BESS).

using a scheme similar to the one described in the previous section. However, the StatCom output power is not set to a constant reference setting (as in the previous section) but rather is required to compensate for the sudden change in line flow. Thus,  $P_{stat}^* = P_{65} - P_{65, scheduled}$ . Since the StatCom reference setting in this example is a “moving target,” the response time will be significantly longer than the 0.1 seconds of the previous example, which had a constant reference value. The voltage control is accomplished using a linear-quadratic-regulator (LQR) control such as that described in [7].

The StatCom/BESS has two control signals with which to achieve the control objectives—the phase angle  $\alpha$  and the modulation gain  $k$ . Therefore, the voltage control objective was assigned to the  $k$  signal, and the oscillatory mode was assigned to  $\alpha$ . Conversely, the only control signal a traditional StatCom has is the phase angle  $\alpha$ . Therefore, this single signal must simultaneously achieve voltage control, and modulation of the interarea oscillatory mode using only locally available signals for feedback. A comparison of the effectiveness of the controls is shown in Figs. 11 and 12. Fig. 11 shows the voltage at Bus 6 at the end of the parallel transmission lines. Both the StatCom and StatCom/BESS are effective in maintaining the voltage at the reference voltage setting, but the StatCom/BESS is able to achieve nearly constant voltage in approximately 0.5 seconds, whereas the StatCom takes nearly two seconds. Note that the StatCom can be used to obtain comparable voltage response to the StatCom/BESS if the objective of oscillation damping were neglected, but since the StatCom output was optimized between the two objectives, its response is not optimal for either objective independently.

The presence of the lightly-damped oscillatory mode can be observed in both the power and voltage waveforms. Immediately following the loss of one of the parallel lines, the active power flow from area 1 to area 2 drops. This sudden topology change perturbs one of the interarea oscillation modes, resulting in a lightly-damped active power oscillation on the remaining lines. However, since the total power demand and generation in the system do not change, the power flow from area 1 to area 2 will return to the scheduled value over

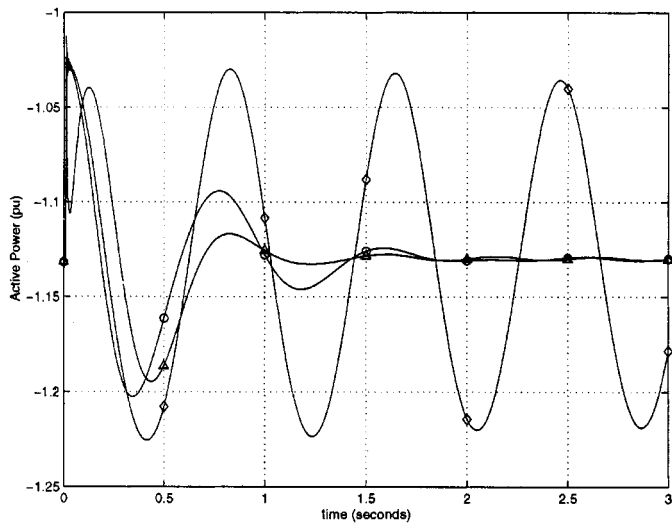

Fig. 12. Active power flow between areas ( $\diamond$ —no control,  $\circ$ —StatCom,  $\triangle$ —StatCom/BESS).

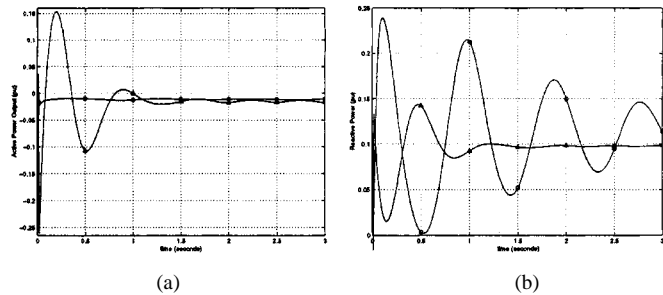

Fig. 13. (a) Active power outlet. (b) Reactive power output ( $\circ$ —StatCom,  $\triangle$ —StatCom/BESS).

time. To fully mitigate the resulting oscillations, the low frequency oscillatory mode must be sufficiently damped by the FACTS controllers. Note that in both power and voltage cases, the StatCom/BESS ( $\triangle$ ) is more effective than the StatCom ( $\circ$ ). This is due to the additional degree of freedom in control and the presence of active power capabilities, especially in the interarea oscillation damping control. Since the StatCom/BESS has two degrees of control freedom, both control objectives can be met independently, whereas the StatCom control must be optimized to achieve both the oscillation damping and the voltage control objectives with a single input.

Fig. 13(a) shows the active power output of the StatCom ( $\circ$ ) and StatCom/BESS ( $\triangle$ ). Note that the active power output of the StatCom/BESS is quite large initially to compensate for the sudden change in power flow, but quickly decays back to nominal. This is important, since it is not desirable to have the battery system in a continual state of charge or discharge. The slight difference between the StatCom output and StatCom/BESS output at steady state is due to the difference in internal losses between the two systems. At steady state, both the StatCom and StatCom/BESS absorb active power to satisfy their internal losses. In addition to the same transformer and device losses, the StatCom/BESS system also includes the internal losses of the battery, which are typically small. The reactive power output is shown in Fig. 13(b). The reactive

power output of the StatCom/BESS system is far more damped than the StatCom system output since the voltage control is achieved independent of the active power control, and is therefore achieved much more rapidly.

#### IV. CONCLUSION

These preliminary results firmly establish the viability of using a StatCom/BESS to enhance power system operation. A method of control was proposed that was shown via simulation and experimental verification to be effective in transmission capacity control, voltage control, and oscillation damping. The StatCom/BESS exhibits increased flexibility over the traditional StatCom with improved damping capabilities due to the additional degree of control freedom provided by the active power capabilities.

#### REFERENCES

- [1] S. Atcitty and S. Ranade, "Summary of state-of-the-art PCS system configurations and recommendations for future research and development," Sandia Report SAND98-2019, Sept. 1998.
- [2] "IEEE Power Engineering Society FACTS Application Task Force FACTS Applications," IEEE Publication 96TP116-0, 1996.
- [3] C. Schauder and H. Mehta, "Vector Analysis and Control of Advanced Static Var Compensators," *IEE Proceedings—C*, vol. 140, no. 4, pp. 229–306, July 1993.
- [4] C. Schauder *et al.*, "Development of a  $\pm 100$  MVAR static condenser for voltage control of transmission systems," *IEEE Trans. on Power Delivery*, vol. 10, no. 3, July 1995.
- [5] C. Schauder *et al.*, "Operation of  $\pm 100$  MVAR TVA StatCom," *IEEE Trans. on Power Delivery*, vol. 12, no. 4, Oct. 1997.
- [6] P. W. Lehn and M. R. Iravani, "Experimental evaluation of StatCom closed loop dynamics," *IEEE Trans. on Power Delivery*, vol. 13, no. 4, Oct. 1998.
- [7] P. Rao, M. L. Crow, and Z. Yang, "StatCom control for power system voltage control applications," *IEEE Trans. on Power Delivery*.
- [8] C. Schauder *et al.*, "AEP UPFC project: Installation, Commissioning and Operation of the  $\pm 160$  MVA StatCom (phase I)," *IEEE Trans. on Power Delivery*, vol. 13, no. 4, Oct. 1998.
- [9] K. V. Patil *et al.*, "Application of StatCom for damping Torsional oscillations in series compensated AC systems," *IEEE Trans. on Energy Conversion*, vol. 13, no. 3, Sept. 1998.
- [10] B. M. Han, G. Karady, J. Park, and S. Moon, "Interaction analysis model for transmission static compensator with EMTP," *IEEE Trans. on Power Delivery*, vol. 13, no. 4, Oct. 1998.
- [11] R. Koessler, B. Fardanesh, M. Henderson, and R. Adapa, "Feasibility studies for StatCom application in New York state," *FACTS Applications*, pp. 8.52–8.58, 1996.
- [12] L. Zhang *et al.*, "A PC-DSP-based unified control systems design for FACTS devices," in *Proceedings of the 2001 Power Engineering Society Winter Meeting*, Columbus, Ohio, Jan. 2001.
- [13] C. W. Taylor, *Power System Voltage Stability*. New York: McGraw-Hill, 1994.

**Z. Yang** received the dual B.S. degrees in electrical engineering and applied mathematics and the M.S.E.E. degree from Tsinghua University in 1994 and 1997, respectively. Currently he is a Ph.D. candidate in electrical engineering at the University of Missouri-Rolla. His research interests include power system dynamic analysis, power electronics and applications in power systems. He is the Member of the IEEE Power Engineering Society, Power Electronics Society, and Eta Kappa Nu honor society.

**S. Chen** received the B.S., M.S., and Ph.D. degrees in electrical engineering from Tsinghua University in Beijing, PRC in 1993, 1995, and 1998, respectively. He is currently a Post-Doctoral Research Fellow in the Electrical and Computer Engineering Department at University of Missouri-Rolla. His research interests include FACTS control and power system stability.

**L. Zhang** received the B.Sc. degree from Zhejiang University in June 1994, and the M.S. degree from the North China Electric Power University in April 1998. She is currently a Ph.D. candidate in the Electrical and Computer Engineering Department at the University of Missouri-Rolla. Her research areas include UPFC control and power system stability.

**M. L. Crow** received the B.S.E. degree in electrical engineering from the University of Michigan in 1985, and the M.S. and Ph.D. degrees in electrical engineering from the University of Illinois in 1986 and 1989, respectively. She is presently an Associate Professor of Electrical and Computer Engineering at the University of Missouri-Rolla. She is a Member of the IEEE Power Engineering Society System Dynamic Performance Committee. Her area of research interests have concentrated on developing computational methods for dynamic security assessment and the application of power electronics in bulk power systems.

**S. Atcitty** received the B.S. and M.S. degrees in electrical engineering from the New Mexico State University in 1993 and 1995, respectively. He is presently a Member of Technical Staff at Sandia National Laboratories in the Power Electronics and Customs Controllers department. His interest in research is high power electronics and applications in power systems. He currently works with Energy Storage System Program at Sandia National Laboratories as a Power Electronics Consultant.