

## INTEGRATION OF VECTOR DATA AND SATELLITE IMAGERY FOR GEOCODING

**Heiner Hild and Dieter Fritsch**

Institute for Photogrammetry (ifp)  
University of Stuttgart

Geschwister-Schöll-Straße 24 D, 70174 Stuttgart, Germany  
email: {dieter.fritsch, heiner.hild}@ifp.uni-stuttgart.de

Commission IV

**KEY WORDS:** Automatic Image Registration, Polygon Matching, Feature Extraction, Data Integration

### ABSTRACT

The geocoding of aerial and satellite imagery is traditionally a tedious manual task. Therefore numerous initiatives for automating the geocoding procedure have been started. Among them, the EU project ARCHANGEL intends to rise a system for automated integration of Image and Map Data for Change Detection. One part of this project aims on automatic geocoding of the different satellite imagery.

The approach of matching satellite imagery and vector data introduced in this paper can be characterized by the use of area objects. Area features are considered to be a subset that can be extracted from both vector data and satellite images. Hence these features represent a sensible basement for the matching process. For the vector side of the processing chain a common vector format was developed which allows the import of vector data from different data bases, for example the German ATKIS data base, vector maps in DXF format or GDF data. Based on this data structure further processing steps like extraction of polygons or selection of certain object classes or layers can be applied. In order to obtain a set of matchable area features the preprocessed vector data are rasterized to be fed into the matching process. Within the image baseline satellite images of various sources like SPOT XS, Landsat TM, MOMS and others can be imported into a uniform image format. Based on this image format a segmentation process is applied to obtain area features from the image data. The applied matching procedure calculates polygon statistics from both the preprocessed and rasterized vector data set and the segmented satellite imagery. In our approach additionally a set of transformation coefficients obtained from a manual tie point editing is used to support the polygon matching. The matching routine subsequently compares the polygon area, the length of the perimeter, the position of the centroid, and the chain frequency of pairs of polygons.

### 1 INTRODUCTION

The automation of the registration of satellite images with GIS data or scanned paper maps as well as with satellite image of the same or a different source relies on a set of conjugate point pairs in both inputs. From these point pairs the transformation between the data sets can be estimated in order to register them. Once image pairs or an image and a map are registered the exactly overlapping inputs can be used e.g. for change detection purposes or automated map updating just to name a few. The automation of the registration of images with images is meanwhile on a highly automated level as it is developed e.g. at the WEU project PAIRS. The image to map registration however is a more sophisticated problem since automatically extractable features have to be found both in the image and the map. An approach for the automatic registration of Landsat TM or SPOT HRV with ADRG digital map imagery which makes use of sensor models is presented in [Lee, 1993]. The automatic derivation of conjugate point pairs can be based on several features: point features, e.g. road intersections, linear features such as roads or river pattern or areal features represented by forests or lakes.

In this paper we present the registration of SPOT 3 XS data with vector data from the German ATKIS data base. In section 2 the processed data sets and the applied conversions are introduced. Section 3 shows the

preprocessing of the image and the vector map data. The basic features used here are area objects which are automatically extracted and preprocessed from the vector data set. From the satellite image a set of polygonal features is extracted by a segmentation algorithm. The polygons form a feature set that can be identified in the image and in the map. In section 4 the matching process which links together the image and vector polygons is described and the result of the processing is presented and discussed. An outlook and possible improvements are given in section 5.

### 2 DATA SETS

To obtain a successful matching between a satellite image and a vector map the used data must contain the desired polygonal features such as forests, villages, grassland or lakes. One of the aims of the implemented system is to handle different satellite image formats as well as different vector map formats. Hence the applied matching is based on a generalised image format for the image data and on a rasterization of the vector map data from a generalised vector format. The chain for the applied conversions is illustrated with Figure 1.

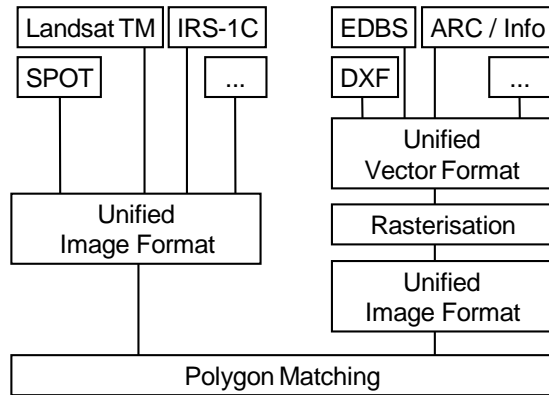

Figure 1: The data conversions performed to obtain an equivalent input to the polygon matching.

### 2.1 Vector Map Data

The vector map data used in our approach is the german digital topographic map ATKIS [AdV, 1988].



Figure 2: 10km x 10km cut of the original ATKIS data set with all objects.

In the ATKIS modelling scheme the real world topographic elements are mapped into objects of seven classes, e.g. vegetation, settlement or water to name a few.

Each class is divided into subclasses where e.g. the vegetation class is subdivided into forest, agriculturally used or grassland.

The ATKIS data are available in three different scales. In Figure 2 there a 10km x 10km section of the original ATKIS data set of the test site in southern Germany is shown.

### 2.2 Image Data

The image data used in this paper is the Normalized Difference Vegetation Index calculated from the red (ch2) and near infrared (ch3) channel SPOT 3 XS. The NDVI is

calculated as follows:

$$NDVI = \frac{ch3 - ch2}{ch3 + ch2}$$

The original ground pixel size is 20m. Figure 3 shows a 10km x 10km section of the NDVI from the SPOT 3 XS test scene.

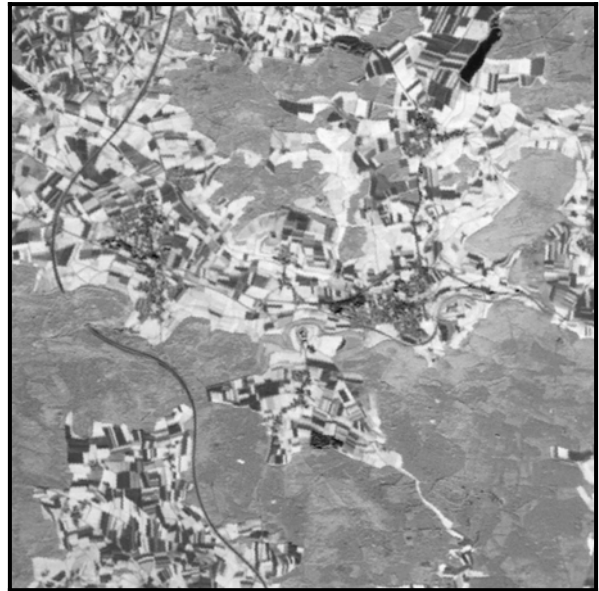

Figure 3: 10km x 10km section of the SPOT XS test data scene (NDVI).

## 3 PREPROCESSING

The matching process presented in this paper is based on input data of the same format, the so called unified raster format. Therefore the image data and the vector data have to be preprocessed to obtain a set of polygonal features for each data source in a format which can be dealt by the matching routine. A set of initial coefficients for a polynomial transformation is expected. In the presented case the matching also needs raster polygon statistics from both the image and the vector polygons. The polygon statistics consist of the polygon area, the perimeter length, the image position of the centroid, the MBR (minimum bounding rectangle), the number and list of the boundary pixels and the chain code frequencies. As it is described in [Abbasi, 1994] the use of chain code frequencies rather than the raw boundary chain code leads to several advantages. The chain code frequencies represent a rotation invariant and highly compressed description of the polygon boundary line which is very suitable for a fast matching algorithm.

The polygon extraction from the image requires a labeled image with the following properties:

- Each region has a unique label.
- The histogram is absolutely dense, i.e. each label is represented exactly once, beginning from 0 is in an ascending suite.

The preprocessing must ensure these properties to avoid a fail of the image polygon extraction.

### 3.1. Vector Map Polygon Extraction

The extraction of polygons from a vector map depends on the input data. Based on the unified object oriented vector format which was developed for the ARCHANGEL project several preprocessing possibilities are supported for the different cases that can occur. Possible data sources are:

- Completely object structured and classified data (as e.g. the ATKIS data set).
- Objectwise grouped data without classes.
- Only geometry data ("spaghetti") without object oriented grouping or internal class information (e.g. the DXF output from a GIS package).

In this paper we limit ourselves to the first point but the implemented routines cover all mentioned cases. The original ATKIS exchange format is EDBS, which stands for 'Unitary Data Base Interface'. Vector information in this format is highly spread and hence the importing routine has to sort all information to gain the object structured data in the developed unified vector format. Once the vector data is object structured the polygon extraction itself is executed. In this processing step polygons are formed from single line elements by first building a node-edge-structure. For every line element in the search space (the whole data set or a single AREA object) all matching lines inside a tunable capture radius are searched and stored with their matching end in the node-edge-list. From each element in this list line chain models are grown. In order to overcome the ambiguity problem, what means to avoid the selection of multiple lines, the candidate with the smallest angle against the direction of the preceding line is chosen. For each new chain element it is checked, whether the open line end matches the beginning of the chain model and hence forms a closed polygon.

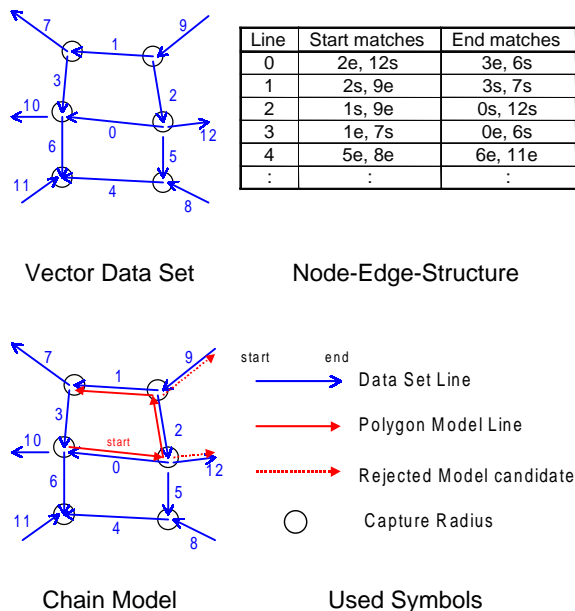

Figure 4: Vector data set polygon extraction by raising a node-edge-list and then finding closed polygons from line chain models.

If corresponding points do not fit exactly, they are replaced with the geometrical average of the two matching line ends in every node. The result of this procedure is a set of exact polygons formed either by the line elements of one AREA object or by all lines in the data set. Figure 4 illustrates the process. The complete data flow processed for the vector map polygon extraction is shown in Figure 5. After the single polygons are extracted a rasterisation is applied and polygons of the same class are merged to single objects in raster space. Since due to acquisition rules not every single AREA object in the vector data set represents the boundaries of visible objects the merging step leads to features that have a chance to be found in the image data set. Each of these agglomerates is given a unique label, represented by different grey value as it is shown in Figure 6. The preparation for the matching is done by the extraction of image polygons which results in the required polygon statistics.

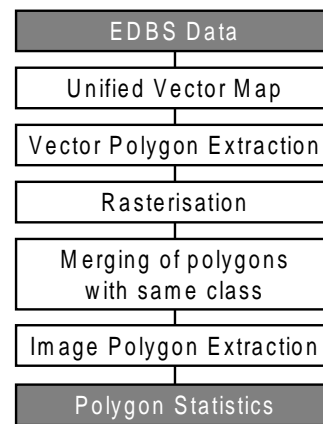

Figure 5: Data flow for the extraction of vector map polygons from ATKIS data.



Figure 6: Rasterised and merged extracted vector map polygons. Each agglomerate is given a unique grey value.

### 3.2 Image Polygon Extraction

The extraction of polygon features from satellite image data is done by a segmentation process based on the unified image format where every image input is converted to. In our case we use SPOT XS multispectral data as described in section 2.2. A detailed description of the applied segmentation process is given in [Dowman, 1997]. The segmentation process works in two steps. In a first step, a classical region growing algorithm, neighboring pixels with similar properties are clustered and thus form regions.

In the implemented process a pixel belongs to a region if the following condition is true:

$$|gv - gv_{av}| < Diff + AvTune * gv_{av} + VTune * \sigma_{gv}^2$$

where

- $gv$  Pixel grey value .
- $gv_{av}$  Average grey value of the candidate region.
- $\sigma_{av}^2$  Grey value variance of the candidate region.
- $Diff$  Grey value difference.
- $AvTune$  Influence factor of the candidate region average grey value.
- $VTune$  Influence factor of the grey value variance of the candidate region.

In the second step of the segmentation the oversegmentation is reduced by performing a merging of segments in the region space. According to the different types of oversegmentation (caused by local distortion, noise, jagged segments in heterogeneous areas) an appropriate procedure is applied to obtain more reliable regions.

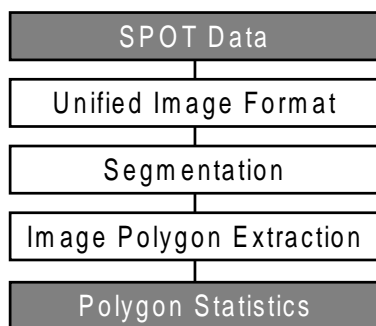

Figure 7: Data flow for the extraction of image polygons from ATKIS data.

From the derived segments image polygon statistics are computed to be fed into the matching. The data flow for the extraction of image polygons is illustrated in Figure 7.

Figure 8 shows the segmentation result of the SPOT XS data.

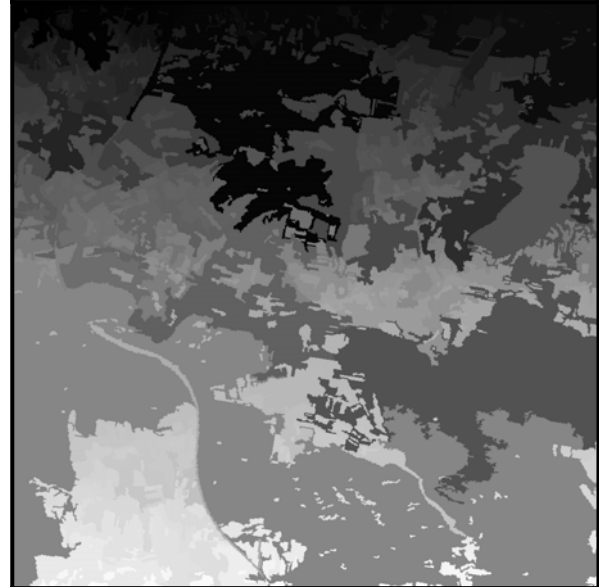

Figure 8: Segmented SPOT XS NDVI image from the test site. Each region has been assigned a unique grey value.

## 4 POLYGON MATCHING

In the polygon matching applied in this approach a set of 2D conjugate points is computed based on the polygon statistics of both satellite image and vector map. A set of initial polynomial transformation coefficients is used to provide approximate values. The procedure depends on the work presented in [Maitre, 1989]. The derivation of the conjugate point pairs is performed in two steps:

- Step 1: Find unitary matching polygon pairs between master (ATKIS, rasterized) and slave (SPOT XS) image.
- Step 2: Extract conjugate point pairs from the boundaries of the matching polygon pairs.

Each centroid of a polygon in the master image is projected into the slave image using the approximate transformation. Each slave image polygon that is hit by the centroid projection is a potential matching candidate. If the differences in all polygon statistic measures of a potential matching pair are smaller than user definable thresholds the match is accepted. In the case of multiple matches no polygon is stored as match since it is not the aim of this process to find all but a reliable set of matching polygons.

In the second step the process tries to match the boundary pixels of the corresponding polygon pairs. Each pixel of the master polygon is projected to the slave image with the actual transformation coefficients. If a slave

boundary pixel can be found inside a user tunable frame around the position of the transmitted master boundary pixel it is accepted as a match and the global transformation coefficients are updated with this additional point pair. When several slave image boundary pixels are lying inside the search frame, the one with the smallest distance residual to the projection center is chosen as matching pixel. In this manner the final transformation coefficients are computed from all successful matches. The results of the matching are shown in Figure 9. An application of the matching process and a more detailed description can be found in [Newton, 1994].

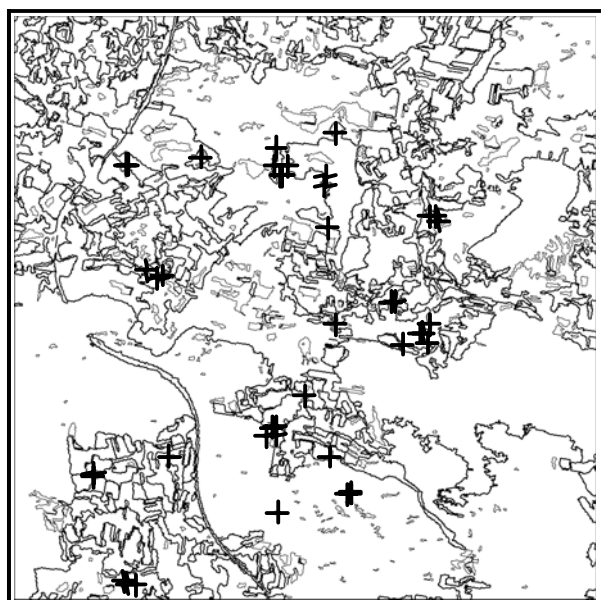
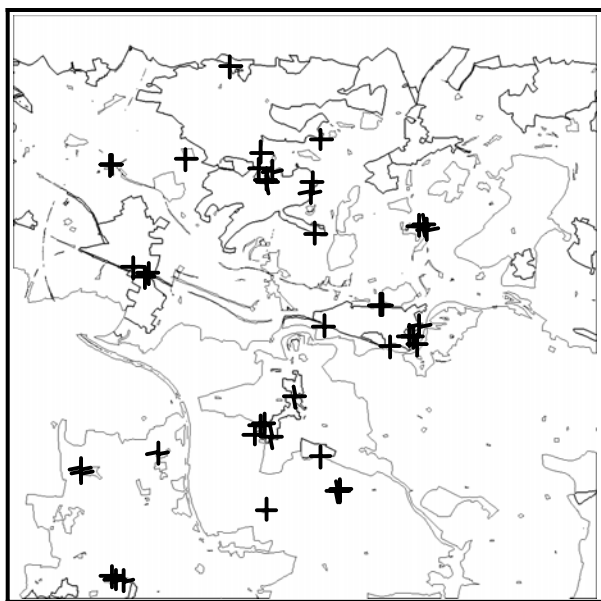

Figure 9: Conjugate points between segmented SPOT image and GIS data set. derived from the matching of polygon boundaries

The polygon boundary matching in the presented example led to 43 well spread conjugate point pairs of which the

transformation coefficients between the satellite image and the vector map are estimated. The whole processing is not mainly designed to obtain a large but a highly reliable number of corresponding points. With the calculation of the 2D transformation the registration is performed. The number of 43 point pairs together with their homogeneous distribution is sufficient to estimate the registration accuracy to better than 1 pixel. The number of points depends on the similarity between extracted image and vector map polygons. This similarity mainly depends on the quality of the image segmentation algorithm.

## 5 CONCLUSION AND OUTLOOK

In this paper we presented a procedure for the automatic registration of satellite imagery with vector map data. Sub pixel accuracy could be achieved. User interaction is only needed to provide initial transformation coefficients and to adjust the parameters of the single processing steps. Based on extracted polygonal features from the satellite image and the vector map the polygon boundary matching routine leads to a set of 43 conjugate point pairs.

Since the applied matching is mainly based on scale dependent features, scale differences of maximal 30% between the image and the map data lead to successful matches. In our approach we ensure a similar scale with choosing a similar pixel size for the vector map rasterisation.

A possible improvement of the results can be obtained by integrating a matching procedure that relies on scale and rotation invariant polygon features as it is presented in [Sester, 1998]. Furthermore the use of image classification results instead of bare segmentation output is a promising way to increase the number of conjugate points and hence improve the registration accuracy.

## 6 ACKNOWLEDGEMENT

The work for the ARCHANGEL project is granted by the European Union (contract no. ENV4-CT96-0306 (DG 12-DTEE) ) which is gratefully acknowledged.

The applied segmentation process was implemented by R.Ruskoné at the University College of London.

The matching routine was developed for the PAIRS WEU-project and implemented by W.Newton, presently at EOS Ltd., Farnham, UK

## 7 REFERENCES

[Abbasi, 1994] ABBASI-DEZFOULI M., FREEMAN T., 1994. Patch matching in stereo-images based on shape. International Archives of Photogrammetry and Remote Sensing 30(3), 1-8.

[AdV, 1988] Amtliches Topographisch-Kartographisches Informationssystem (ATKIS). Arbeits-gemeinschaft der Vermessungsverwaltungen der Länder der Bundesrepublik Deutschland (AdV), Bonn.

[Dowman, 1997] DOWMAN I. and RUSKONÉ R., 1997. Extraction of Polygonal Features From Satellite Images For Automatic Registration. Automatic Extraction of Man Made Objects from Aerial and Space Images (II), Monte Verità.

© Birkhäuser Verlag 1997, 343-354.

[Lee, 1993] LEE A. J., CARENDER N. H., KNOWLTON D. J., BELL D. M., BRYAN J. K., Fast autonomous registration of Landsat, SPOT and digital map imagery. Integrating photogrammetric techniques with scene analysis and machine vision. SPIE 1944. 68-79.

[Maitre, 1989] MAITRE H. AND WU Y., 1989. A Dynamic Programming Algorithm for Elastic Registration of Distorted Pictures Based on Autogressive Model. IEEE Transactions on Acoustics, Speech and Signal Processing, 37(2), 258-297.

[Newton, 1994] NEWTON W., GURNEY C., SLOGGETT D., DOWMAN I., 1994. An Approach to the Automated Identification of Forests and Forest Change in Remotely Sensed Images. International Archives of Photogrammetry and Remote Sensing, 30(3). 607-614.

[Sester, 1998] SESTER M., HILD H., FRITSCH D., 1998. Definition of Ground Control Features For Image Registration Using GIS-Data. Proc. ISPRS Comm.III Symposium 1998 Ohio, USA.