

Intelligent Accident-Detection And Ambulance- Rescue System

Bhandari Prachi, Dalvi Kasturi, Chopade Priyanka

Abstract: Road accidents and traffic congestion are the major problems in urban areas. Currently there is no technology for accident detection. Also due to the delay in reaching of the ambulance to the accident location and the traffic congestion in between accident location and hospital increases the chances of the death of victim. There is a need of introducing a system to reduce the loss of life due to accidents and the time taken by the ambulance to reach the hospital. To overcome the drawback of existing system we will implement the new system in which there is an automatic detection of accident through sensors provided in the vehicle. A main server unit houses the database of all hospitals in the city. A GPS and GSM module in the concerned vehicle will send the location of the accident to the main server which will rush an ambulance from a nearest hospital to the accident spot. Along with this there would be control of traffic light signals in the path of the ambulance using RF communication. This will minimize the time of ambulance to reach the hospital. A patient monitoring system in the ambulance will send the vital parameters of the patient to the concerned hospital. This system is fully automated, thus it finds the accident spot, controls the traffic lights, helping to reach the hospital in time

Introduction

Existing System

Currently there is no technology for accident detection. As it is done manually there is loss of life in golden hours. The accident victim is dependent on the mercy of others to rush him to hospital. Many a times an accident goes unnoticed for hours before help comes in. Due to all these factors there is a high rate of mortality of the accident victims. In addition to this there is delay in the ambulance reaching the hospital due to the traffic congestion between accident location and hospital which increases the chances of the death of victim.

Proposed system

To overcome the drawback of existing system we will implement the new system in which there is an automatic detection of accident. A sensor, GPS, GSM unit fitted in the vehicle detects the accident and sends the accident location to a main server unit which houses the database of all the nearby hospitals. An ambulance is rushed to the accident spot which carries the patient to the hospital and simultaneously monitors the vital parameters like temperature and pulse rate and conveys them to the concerned hospital. Along with this there would be control of traffic light signals in the path of the ambulance via RF communication to provide a clear path for the ambulance. This will minimize the time required by the ambulance to reach the hospital.

Intelligent accident-detection and Ambulance-rescue system

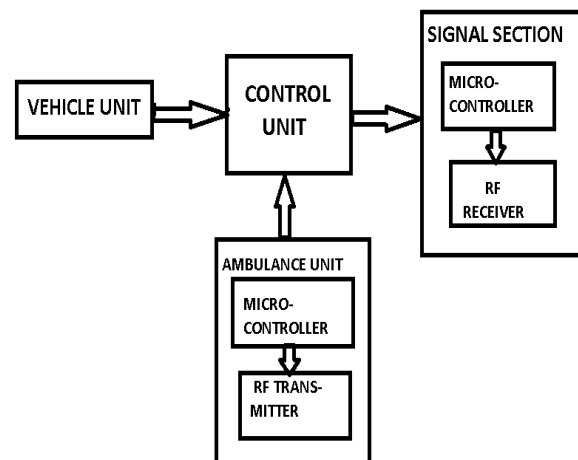

Fig1: block diagram of system

The system consists of three main units, which coordinate with each other and make sure that the ambulance reaches the hospital without any time lag. Thus our system is divided into following four units:

1. The vehicle unit.
2. The ambulance unit.
3. The traffic junction unit.
4. The control unit.

1) Vehicle unit

For implementation of this project, vehicle unit should be installed in every vehicle. It consists of microcontroller along with the accelerometer, GPS and GSM module and sensors to sense the accident. On impact on the vehicle, information about accident is sent to the main server. This information consists of the location of accident detected by GPS module installed in vehicle. The GPS system finds out current position of vehicle (latitude and longitude) which is the location of accident spot and gives that data to GSM module. This information to the main server is conveyed by GSM module. There is also provision of avoidance of

- Bhandari Prachi, Dalvi Kasturi, Chopade Priyanka
- Department of electronics & telecommunication Engineering, Bharti Vidyapeeth's College of Engineering for women, Pune-43, India.
- prachibhandari321@gmail.com,
kasturidalvi99@gmail.com,
chopade.priyanka5@gmail.com

accident by using accelerometer (ADXL 335). Accelerometer alerts the driver by turning on the buzzer whenever the position deviates from the normal.

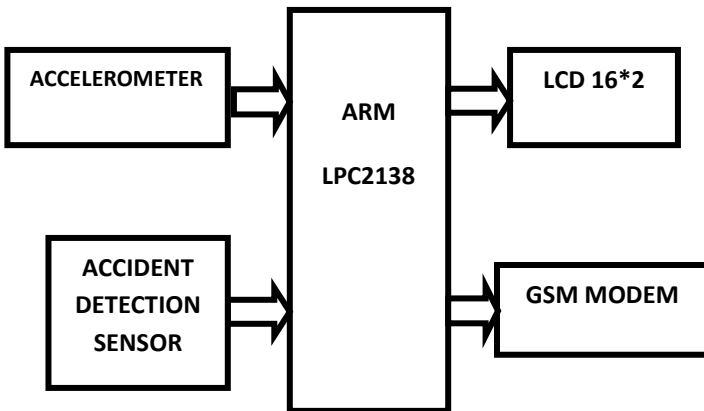

Fig2: block diagram of vehicle unit

Control unit:

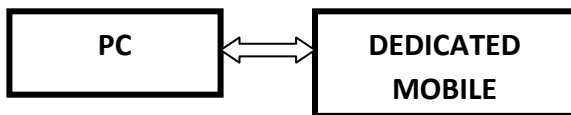

Fig3: block diagram of control unit

Control unit is the brain of our system. Practically, the control unit will house all the database of all the nearest hospitals in order to send an ambulance to the accident spot. It receives the message about accident location from the GPS and GSM module installed in vehicle unit and responds accordingly.

Ambulance unit:

Control unit sends the ambulance to the accident location. Ambulance collects the victim from the accident location. While in the ambulance the vital parameters of the patient temperature and pulse rate are continuously monitored and conveyed to the concerned hospital. We are using LM35 temperature sensor whose output voltage is linearly proportional to the Celsius (centigrade). For measuring pulse rate we are using IR based obstacle sensor. Normally there is delay in ambulance reaching the hospital due to traffic congestion. To overcome this delay, the traffic signals in the path of ambulance are controlled via RF communication. The ambulance section consists of an RF transmitter and the traffic unit will consist of the RF receiver. The RF transmitter on the ambulance will communicate with the RF receiver of the signal section and make the signal green whenever it is within a 100m radius. As a result of which the ambulance will have a clear path all along its way to the hospital without any traffic congestion.

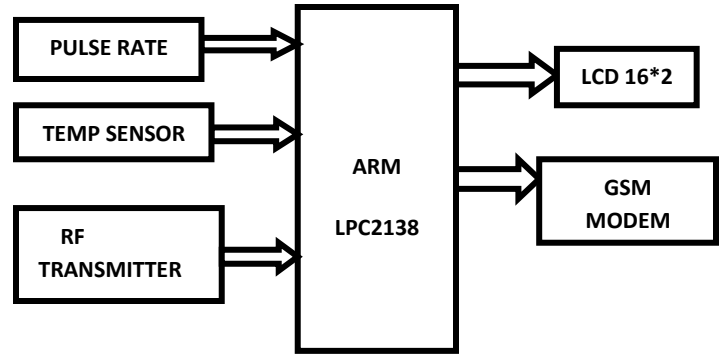

Fig4: block diagram of ambulance unit

Traffic junction unit

Whenever the ambulance reaches to the traffic signal (approximately 10m) the traffic signal will be made to green through RF communication. Thus the ambulance will have clear path to reach the hospital without any traffic congestion along the way. This system is fully automated, thus it finds the accident spot, controls the traffic lights, helping the victim to reach the hospital in time.

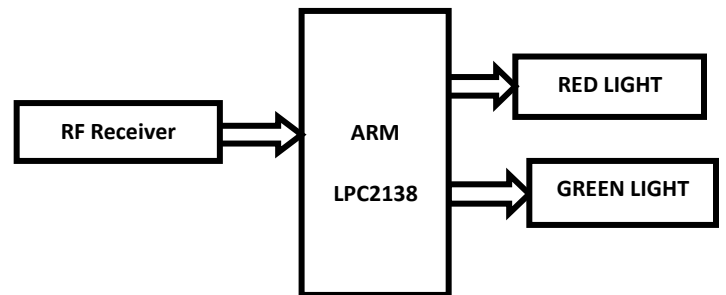

Fig5: block diagram of traffic junction unit

Results:

Thus we have developed the above mentioned units and successfully coordinated the system. For the main server unit we have created a database using visual basic 6.0 on PC. For the prototype the communication between the ambulance and traffic unit takes place via RF transmitter and RF receiver.

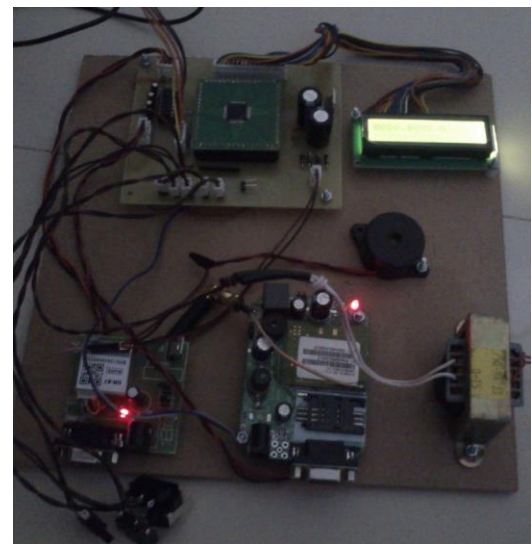



Fig6: vehicle unit and accident location displayed on the LCD

Figure shows the vehicle unit and the position of accident as detected by the GPS in Vehicle unit. The accident location is then sent to the main server unit that houses the database of all the nearby hospitals and sends an ambulance to the accident spot.

In the ambulance the vital parameters such as temperature, pulse rate etc. are continuously monitored and send to the concerned hospital.

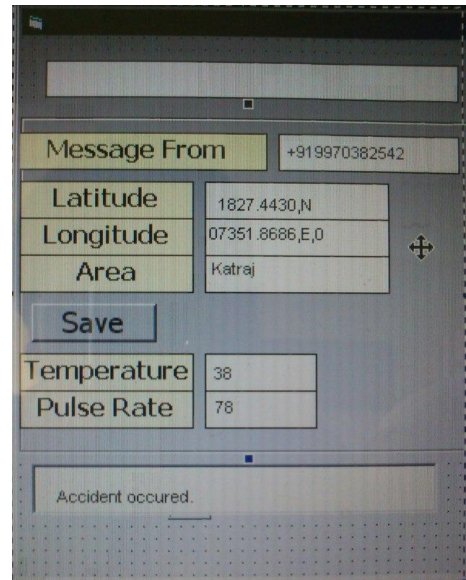

Fig 8: The main server database.

The figure above shows the database as created using visual basic 6.0 on PC.

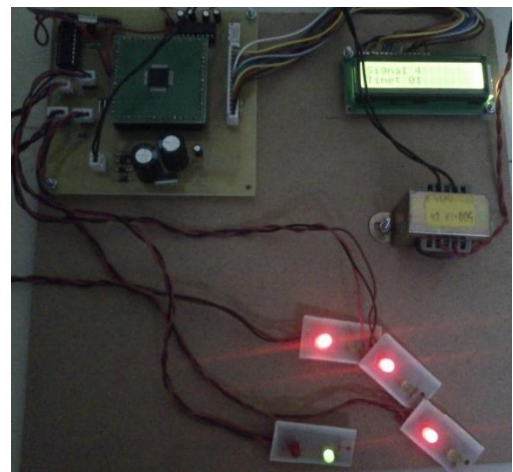
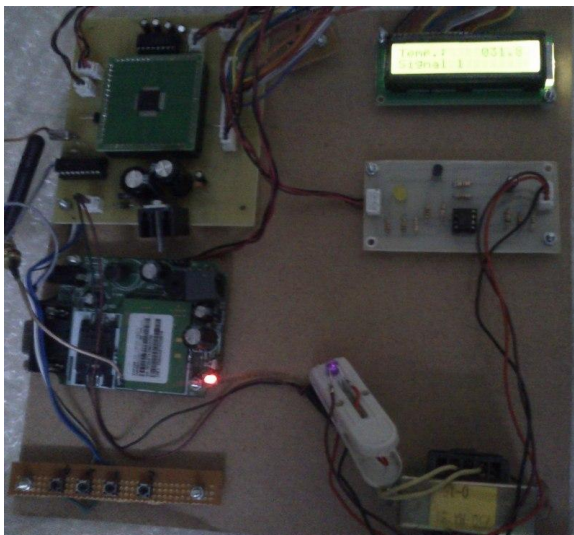

Fig 9: Traffic junction unit.

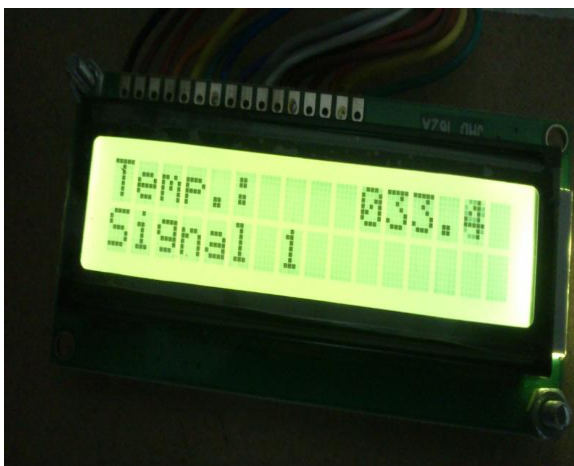

Fig 7: Ambulance unit and vital parameters displayed on LCD.

All the traffic signals in the path are controlled via RF communications

Conclusion:

Thus we have presented a system to detect accident automatically and give a clear way to emergency purpose vehicles on road so that they can reach their destination in least time without stopping at traffic intersection. This system can be effectively implemented for an entire city or countries with large population like India for better results.

Acknowledgement:

The authors are thankful to IJSTR Journal for the support to develop this document. We also sincerely thank

Prof.S.A.Itkarkar for her constant support and guidance.

References:

- [1]. Wang Wei, Fang Hanbo , "*Traffic accident automatic detection and remote alarm device*", Proceedings of IEEE International Conference on Electric Information and Control Engineering, pages: 910-913, 2011.
- [2]. Mr.S.Iyyappan and Mr.V.Nandagopal , "Accident Detection and Ambulance Rescue with Intelligent Traffic Light System", published in International Journal of Advanced Technology and Engineering Research,2013.
- [3]. K.Athavan; S.Jagadeeshwaran, G.Balasubraminan, N.Dinesh, G.Abhilash, G.Gokul "Automatic ambulance rescue System", Proceedings of 22nd IEEE International Conference on Tools with Artificial Intelligence, pages:190-195, 2012.
- [4]. Amnesh Goel ,Sukanya Ray ,Nidhi Chandra, "Intelligent Traffic Light System to Prioritized Emergency Purpose Vehicles based on Wireless Sensor Network ",published in International Journal of Computer Applications , Volume 40– No.12, February 2012 .

Biography

The paper is written by Dalvi Kasturi currently a student of BE in Electronics & telecommunication Engineering in Bharti Vidyapeeth's college of engineering for women ,Pune India & will complete the degree in the year 2014.

She may be reached at Kasturidalvi99@gmail.com.

The paper is written by Bhandari Prachi currently a student of BE in Electronics & telecommunication Engineering in Bharti Vidyapeeth's college of engineering for women ,Pune ,India& will complete the degree in the year 2014. She may be reached at

prachibhandari321@gmail.com

The paper is written by Chopade Priyanka currently a student of BE in Electronics & telecommunication Engineering in Bharti Vidyapeeth's college of engineering for women ,Pune , India and will complete the degree in the year 2014. She may be reached at

chopade.priyanka5@gmail.com