

Intelligent Infrared Target for training Commandos to Combat Urban Terrorism

L.V. RAJANI KUMARI, Y. PADMA SAI, AND N.BALAJI

ECE Department

VNRVJIET

Bachupally, Hyderabad

INDIA

anumolurajani@gmail.com, ypadmasai@gmail.com, narayanamb@rediffmail.com

<http://www.vnrvjiet.ac.in>

Abstract: - The commandos are required to possess very quick reflexes for a surprise enemy presence in combing operations particularly in terrorist's attacks in urban areas. Therefore, it is necessary for commandos to receive rigorous training in environments that simulate real-life urban combat conditions as closely as possible. In this paper, we designed an Infrared (IR) target for commando training in urban areas. The designed system is based on Infrared technology which will train the commando in a simulated environment and evaluates the performance based on his response time in a given short period. The system has Passive Infrared Sensor (PIR) and IR Transmitter combined in one module and a microcontroller based target.

Key-Words: - Commando, Infrared, Zigbee, Control Station, Passive Infrared Sensor, IR transmitter, Target.

1 Introduction

Urban terrorism is of more recent vintage and is more diabolical in nature. Terrorists prefer urban areas because of its 'target-rich environment', i.e. the presence of a 'defined enemy' in abundance like laymen, officials, foreign nationals, corporate heavy weights, government buildings, railway stations, airports, foreign embassies and communication centers etc. It is increasingly necessary for a small number of lightly armed soldiers to enter into one or more buildings infected by armed terrorists and other hostiles and to eliminate these hostiles, rescue hostages and secure the area from counter-attack. In many cases unarmed civilians are also present and they must not be harmed to the extent possible. Therefore, it is necessary for soldiers to receive rigorous training in environments that simulate real-life urban combat conditions as closely as possible.

In this paper, the proposed IR Target is useful for training the Commandos in a simulated urban area environment. The brief operation of this system is as follows. During training, Multiple rooms in a building are equipped with IR targets, which can be enabled through the control station. When the commando enters the room, a Passive infrared

sensor which is connected near the door detects the human motion and sends the signal to an IR transmitter. An IR receiver receives the IR signal and sends the signal to the target. The target is to be enabled by the control station, before the target receives the signal from the IR receiver, so that the target is popped-up for a specified time. The commando has to shoot the target within that specified time. The commando does not have prior knowledge of the presence and location of the target unit.

The Target Unit acts as a mock terrorist. A battery operated target comprises of a motorized mechanical unit to pop-up or pop-down a terrorist model made up of card board, driven by a microcontroller. The microcontroller operates a motor which will pop-up or pop-down the target with its clockwise and anti clockwise rotations.

Zigbee wireless standard has chosen as a communication protocol between the Control Station and the Target unit. Target unit collects information from the control station and implements commands directed by it. The sample target model made up of card board is shown in Fig. 1.



Fig. 1 Card board model of the target

As wireless networking technologies invade the environment, many wired connection services are now being replaced by wireless equivalents. This wireless connection provides simple but effective control and monitoring methods. Infrared radiation exists in the electromagnetic spectrum at a wavelength that is longer than visible light. It cannot be seen but it can be detected. Objects that generate heat also generate infrared radiation and those objects include animals and the human body whose radiation is strongest at a wavelength of 9.4um. Infrared radiation in this range will not pass through many types of material that pass visible light such as ordinary window glass and plastic.

Infrared is a low cost, low power, short range wireless technology. Infrared technology allows computing devices to communicate via short-range wireless signals. With infrared, computers can transfer files and other digital data bidirectional. Hence IR technology is employed in the present system. Deployment of the proposed system is shown in Fig. 2.

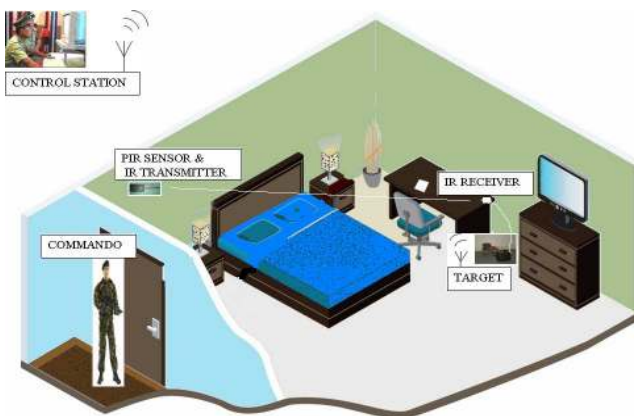

Fig. 2 Deployment of IR Target

2. Designed System Hardware

The block diagram of designed system is as shown in Fig.3. It consists of PIR sensor, IR transmitter, AT89C51 microcontroller, IR receiver, Xbee module and motor.

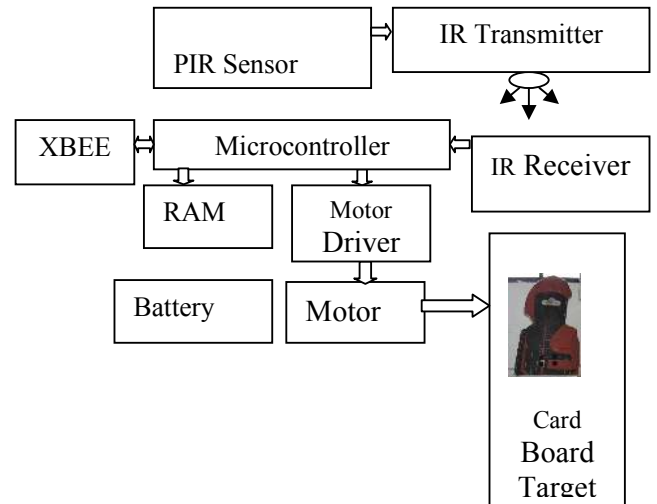

Fig. 3 Block Diagram of an IR Target

PIR sensor can detect the thermal radiations emitted by an object between wavelengths of about 9.4 μm and 12 μm in such a way that they can be calibrated to detect human presence in a given area [2].As the system is developed exclusively for training commandoes and it is necessary to maintain the training environment free from moving objects other than the commandoes. The PIR sensor is not completely exposed and a part of the PIR sensor is covered by encasing to limit the wide range and detect the human in the intended direction. PIR Sensor and IR Transmitter are combined as a module that transmits IR signal whenever the PIR sensor detects the human motion.

The target unit consists of a microcontroller based mechanical system, Xbee module and Infrared receiver. A battery operated target comprises of a motorized mechanical unit to pop-up or pop-down the terrorist model made up of card board, driven by a microcontroller. The power supply to the motor is cutoff after the target reaches its desired position.

2.1 Passive Infrared Sensor

PIR sensor is used to detect human motion. The PIR Sensor detects motion up to 20 feet away by using a Fresnel lens and Infrared-sensitive element to detect changing patterns of passive infrared radiation emitted by objects in its vicinity.

PIR is basically made of a pyroelectric sensor, which can detect levels of infrared radiation as every object emits radiation. The pyroelectric sensor is made up of a crystalline material that generates a surface electric charge when exposed to heat in the form of infrared radiation. When the amount of radiation striking the crystal changes, the charge generation also changes. Fig.4. shows a 555-28027 PIR sensor chosen for the system.



Fig. 4 PIR Sensor

2.2 IR Transmitter

The IR transmitter used in the system is same as the one that is more commonly used in all remote controls. The transmitter circuit consists of two square-wave oscillators, one is made by using two transistors and other one is 555 timer IC set up as astable multivibrators. Transistor version astable multivibrator running at 20Hz and the other running at 38KHz. The 38 KHz frequency acts as a carrier wave and is required by the IR receiver module on the receiver board. The modulated output is used to drive the IR LED. The IR signal is modulated at around 36-40 KHz in order to avoid interference from sources of IR light. The carrier frequency is amplitude modulated by the data, usually full on/off type modulation.

2.3 Zigbee

In many applications ZigBee-based wireless devices operate in 2.4 GHz frequency band with maximum data transfer rate of 250 K bits per second. ZigBee uses two modes of addressing, 16 bit short address and a 64 bit extended address.

The XBee devices of M/s Digi International were used for designing the present application. Digi API do not contain any application program. A program is developed using visual basic(VB).net to establish a wireless network among the control station and all the targets. In the proposed design Xbee pro is used as it has indoor/urban range of 100 m and outdoor line of-sight range is up to 1.6 km. The design employed a mesh network configuration [4]. One XBee-pro device connected to a Laptop's USB port, which acts as control station. The second XBee-Pro is connected to the router placed nearest to the control station.

2.4 IR Receiver

The circuit consists of TSOP1738 IR Receiver. The TSOP1xxx series is designed to suppress spurious output pulses due to noise or disturbance signals. Data and disturbance signals can be distinguished by the devices according to carrier frequency, burst length and envelope duty cycle. The data signal should be close to the band-pass center frequency. When a data signal is applied to the TSOP1xxx in the presence of a disturbance signal, the sensitivity of the receiver is reduced to ensure that no spurious pulses are present at the output.

2.5 Target

The Target consists of power supply unit, microcontroller, Xbee module, relay and motor. The wireless module used for the project is Xbee Pro, which confirm to the IEEE 802.15.4 standard manufactured by MaxStream, Inc. The IEEE 802.15.4 wireless standard, more commonly known as Zigbee is ideally suited for this project. The Xbee module acts as a transceiver for receiving commands from Control station to the target.

The AT89C51 is a low-power, high-performance CMOS 8-bit microcontroller with 4K bytes of In-System Programmable Flash memory. The

microcontroller receives data from Xbee module and drives the relays. The communication between Xbee and microcontroller is in terms of frame formats. The AT89C51 microcontroller is programmed to be used as an interface between the Xbee and motor. The target is to be enabled by the control station through Xbee module. IR Receiver is also connected to the target. After receiving the 'EN' command from the control station, it waits for IR signal.

Whenever the IR receiver receives IR signal, the motor is activated by microcontroller through relays to pop-up the dummy terrorist card board model for a predefined time.

2.6 Control Station

The control station is central monitoring, processing, tracking and data storage station. Control station comprises of hardware board and Personal Computer (PC). The hardware board consists of Xbee Pro module and USB to UART converter IC. This Xbee Pro acts as the coordinator for the overall WSN system. The Xbee-Pro devices can be configured as coordinator or router by loading appropriate firmware X-CTU supplied by M/s Digi International. The control station has an application program to establish a wireless network among itself and all the targets. The Control Station PCB is shown in Fig 5.



Fig. 5 Control Station

3 Network Establishment

The Module at control station should be configured as coordinator with particular Personal area network identification (PANID) to form a personal area network. All those Modules configured as Routers with same PANID join this network. The Target Unit XBee Module configured as Router to join the control station network. The manufacturer assigns 64 bit serial number for each device with a Serial number Low(SL) and Serial number High (SH) each of 32 bit length. Initially, the application program will resolve to make sure that all the routers in the network join the coordinator. The communication between control station and the target is achieved successfully using the frame formats. The general structure of the command frame is shown in the Fig. 6.

Start Delimiter 0x7E	Length	API Identifier 0x08	Frame ID	cmdnd data	Checksum 1byte
-------------------------	--------	------------------------	----------	------------	-------------------

Fig . 6 Command frame format

The Xbee module is reset to receive "FR" command from the microcontroller. Now Xbee module is ready to join in a network as it is configured with the same ID . The structure of the FR command frame is shown in Fig.7.

Start Delimiter 0x7E	Length 0x0004	API Identifier 0x08	Frame ID 0x52	AT Command 0x46(F), 0x52(R)	Check sum 0x0D
-------------------------	------------------	------------------------	------------------	-----------------------------------	-------------------

Fig. 7 FR command frame format

Association Indication (AI) command is sent to determine the status of the start up operation. The Zigbee network is established and ready for data transmission. The structure of the AI command frame is shown in Fig.8.

Start Delimiter 0x7E	Length 0x0004	API Identifier 0x08	Frame ID 0x52	AT Command 0x41(A) 0x49(I)	Checksum 0x1B
-------------------------	------------------	------------------------	------------------	----------------------------------	------------------

Fig. 8 AI command frame format

3.1 Data Exchange

After the network connection is established, the microcontroller sends a request frame (RF) to indicate that it is ready to receive. It may be seen from the data frame that destination control station's serial number in terms of SL and SH are added in the data frame. A one byte ASCII code is embedded into the data frame (15th byte). The bytes 12 and 13 indicate that the 16 bit network address as shown in Fig.9.

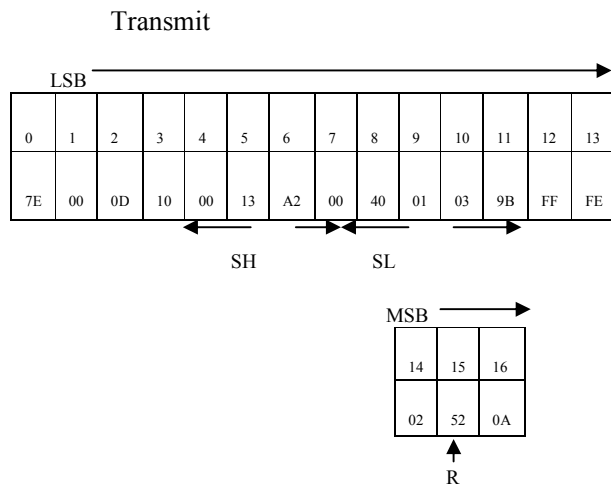

Fig. 9 Request frame

Upon receiving the Request frame, the Control Station enables the target by an Enable (EN) command. An ASCII two byte control word is placed in bytes 14 and 15 of the data frame. The ASCII data 'E' and 'N' indicate that it is enable signal to the target. The data frame received by the microcontroller from the control station is shown in Fig.10.

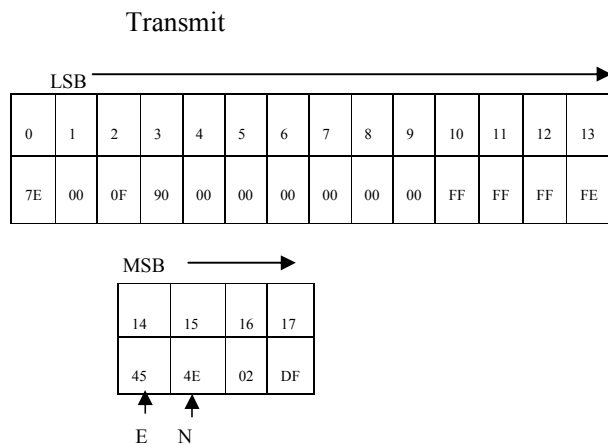

Fig. 10 The EN control-data frame

The microcontroller receives and analyzes the frame and waits for the IR signal.

Fig. 11 shows the assembled PCB of a PIR sensor and an IR transmitter. The complete casing of the PIR sensor and IR Transmitter is shown in Fig. 12.



Fig. 11 PCB photo of PIR sensor and IR transmitter



Fig. 12 Casing of IR transmitter

4 Results

An IR target is implemented successfully. After the implementation, the target is tested for the required specifications of rise time, hold time and fall time as indicated in the Table 1.

TABLE 1 Tested Parameters

Specification of target	Test status
target raised in 1 sec	pass
Hold time of target 3 sec	pass
Target fall in 1 sec	pass

The communication between control station and the target is carried out successfully using the frame formats.

The target rises within 1 second, when the motor runs in clock-wise direction. The target is held in vertical position for 3 seconds. The holding time of the target is programmable. The power supply to the motor is disconnected after the target reaches vertical position. After 3 seconds the motor runs in anti-clockwise direction, and the target will fall back to its original position. It takes one second to reach fall position.

The target in raised position is shown in Fig.13 for two to three seconds whenever it receives the "EN" data in the form of frame format from Control Station and IR signal from IR transmitter. After three seconds it goes to normal fall back position as shown in Fig 14.



Fig. 13 Target in raised position



Fig. 14 Target in normal position

4 Conclusion

In this paper, the others designed and implemented an IR target to train the commandos in urban areas. The implemented system has the following advantages.

- i. The system is fully automated and there is no human interaction for controlling the target.
- ii. The system readily simulates the surprise enemy target with the desired hold and fall times.
- iii. The system examines the speed of reflexes of the commando useful for quick performance analysis of the commando.
- iv. The system consumes low power.

References:

- [1]. Alka R Kaushik, Branko G celler, "Characterization of passive Infrared Sensors for Monitoring occupancy pattern", School of Electrical Engineering and Telecommunications, Biomedical Systems laboratories, University of N.S.W, Sydney, Aug 30-Sept 3, IEEE 2006
- [2]. Zhiqiang Zhang, Xuebin Gao Graduate University, Chinese Academy of Science, Jit Biswas, Jian Kang Wu, Institute for Infocomm Research, Singapore, "Moving Targets Detection

and Localization in Passive Infrared Sensor Networks”.

- [3]. Yu-Wei Su, and Chung-Chou Shen, “A Comparative Study of Wireless Protocols: Bluetooth, UWB, Zigbee, and Wi-Fi”, the 33rd Annual Conference of the IEEE Industrial Electronics Society, Nov. 5-8, 2007.
- [4]. Product Manual v8.x17 Beta - ZigBee Protocol For OEM RF Modules XB24 and XB24-PRO, M/s MaxStream, Inc
- [5]. Mao-Cheng Huang et al, “The Wireless Sensor Network for Home-Care System using Zigbee”, Department of Electronic Engineering, National Kaohsiung University of Applied Sciences, Kaohsiung, Taiwan.
- [6]. Chee-Yee Chong, and Srikanta P. Kumar, “Sensor Networks: Evolution, Opportunities, and Challenges,” Proceedings of the IEEE, vol. 91, Aug. 2003.
- [7]. Jeremy Schiff and Ken Goldberg, “Automated Intruder Tracking using Particle Filtering and a Network of Binary Motion Sensors”, Dept. of EECS, University of California, Berkeley Proceeding of the 2006 IEEE
- [8]. Wendong Xiao, Jian-Kang Wu and J. Vedyas, “Multi-target Tracking System using Ultrasonic Sensor Network,” The Fourth International Symposium on Information Processing in Sensor Networks, 2005.