



Internet of Energy: A Design to Manage Energy Consumption for Off-Grid Building

Ahmed J. Abid^{1, *}

¹Middle Technical University

(Received 6 May 2017; Accepted 15 March 2018; Published on line 1 March 2019)

*Corresponding author: dr.ahmedjabbar@yahoo.com

DOI: 10.5875/ausmt.v9i1.1408

Abstract: This article offers an Internet of thing (IoT) based energy management system, that provide an automation concept and completely control the consumed energy by observing the delivered power from a limited and/or unreliable power sources. An example for such sources are photovoltaic and wind renewable energy where the supplied power depends on the weather conditions which make it fluctuated and unreliable. The proposed system offers a complete solution to reduce the consumed power based on the available power with less affecting on the quality of life. This article presents a cloud computing master unit that communicates with all the building devices via WIFI network nodes. These nodes are responsible for calculating the consumed energy by each connected device and deliver this information to the cloud. The system enables the user to schedule the devices' levels of priority in a list, priority list. The master controller unit calculates the available power based on instantaneous supplied power from the source, stored energy, weather prediction, and priority list, then make a decision to keep all the devices powered on or shut down some of them for a while according to the list.

Keywords: Off grid building; Energy management; Energy consumption control; Energy efficiency; Internet of things; quality of life; Wireless sensor network; Renewable energy

Introduction

Energy consumption management can be achieved by user conscious of momentary energy consumption. In spite of the new building design takes a further steps to reduce the consumed energy [1], [2], but when the building is grid-off and a completely standalone with no grid injection[3], [4]. The shading in the produced or the stored energy may cause a serious problem and affect life quality. This is happening when a renewable energy source is used, such as solar or wind source, since these sources are affected by weather fluctuations. So, an instant decision must be taken to reduce the power consumption.

The Internet of Energy term is a trend term used here to describe how the internet of thing (IoT) can be used to provide an innovative automation concept for power distribution, stored energy monitoring, grid

surveillance and communication. It will allow units of energy to be transferred when and where it is needed, especially when there is a shading in the supplied power or limited resources. Power consumption monitoring is performed on all levels, from local individual devices up to national and international level [5].

In a smart grid scenario, energy consumption will be manipulated by a volatile energy price which again is based on the momentary demand (acquired by smart meters) and the available amount of energy and renewable energy production[6].

Many researchers discussed controlling the energy consumption without taking the limited resources into consideration, as in [7]. Other Authors, offers a smart meter that gives information about the instantaneous energy consumption, thus allow to identify and eliminate devices that wasting energy, and provides hints for optimizing individual energy consumption, or for devices scheduling strategies as in [8], [9], which may affect the quality of life. But the presented design allows the user to

schedule the devices' priority in multi-level.

Devices management in smart home industry visions is a matter of the contradiction between complexity and simplicity, where an expanded range of devices, services and options are marketed as a way to simplify and enhance everyday practices.

A promoted side-benefit is reduced and more efficient energy consumption [10]. Add for that Cloud-based Home Energy Management (HEM) can provide intuitive and automated services that can not only save money and energy but also improve the quality of lives of consumers [11].

Using ZigBee as a transceiver, could be a good solution to manage smart home as in [12]–[15], but it could add more cost to the system and it still required a gateway to the cloud. The shading in solar energy sources that caused by passing clouds or in specific months of the year is also discussed in [16], which required an instance response to avoid the lack in the supplied power which may cause a complete shutdown. But the presented article discussed managing the building's devices, according to their power demand, level of priority, stored energy, and the available power. It may shut down some devices when:

- There is a shade in power.
- To decrease the power consumption under a certain level.
- To save the electricity bills without affecting the quality of life.
- Avoid total shutdown at the peak load with limited resources.
- Offer different level of priority for the same device at different times.

All that will be managed with an intelligence system that will be able to control the whole devices in the building via wireless sensor network (ESP8266 NodeMCU). When the system starts up, its measure the supplied power by the renewable source or sources, the storied energy, and the delivered power into the loads. Then it will be in charge of controlling all the loads based on a scheduled list of priorities which be explained later in this article.

Dr. Ahmed J. Abid received the B.Sc. and M.Sc. degrees in Electronic Engineering from the Department of Electrical and Electronic Engineering, University of Technology, Baghdad, Iraq in 2002 and 2004 respectively. He also received his Ph.D. degree in "Electronic and Communication Engineering" from University of Basrah, Basrah, Iraq in 2014. He has been working as an instructor in the Dept. of Electronic Engineering, Technical Instructor Training Institute (TITI), Middle Technical University, Baghdad, Iraq since 2006. He has been Head of the Technical Electronic Department at TITI since 2014. Dr. Abid has published many scientific and technical papers in international and national journals and conferences. His research interests include solar photovoltaic farm, renewable energy, energy management, power line communication and embedded system design.
Email: dr.ahmedjabbar@yahoo.com

System Structure

The proposed system mainly consists of software and hardware parts. The software part manages the server and clients. In general, the server controller could be any desktop computer, laptop, tablet and/or smart phone that can manage the website. It communicates with all the clients' controller via the ethernet.

The presented system offers a server that can be managing all clients via local network or over the ethernet. The hardware part of each client is consisting of ESP8266 as a sensor and control unit as shown in Fig.1. Each Node can use as a gateway to reach the node that out of reach the wireless router for example, node#3 is connected to the wireless router via node#2.



Figure 1. System Architecture[17].

Software Flowchart

The flowchart in Fig.2 is presented the website controlling algorithm. User name and password is used as a matter of securing the website. After logging in, the user will have full authority to control and monitoring the all the connected devices. While the user is signed in, the website will start repeatedly sending requests for all the connected nodes, these nodes will replay the devices' status and the sensors' reading every two second to keep the system up to date.

The next step is selecting the energy management strategy (*Manual* or *Auto*), if the Auto mode is selected the system will manage all the connected devices automatically and based on the available power *AP* and the demand power *DP*, but if the manual mode is selected, it is required to select the priority manually.

Now the user must set the priority level of all the devices otherwise they have a high priority in default. The

level of system priority in the Auto Mode is calculated at this stage, and to do that, the website measure the available power and the load power. The available power calculations are briefly described in the result and discussion section.

The total building load achieved by sensing of the main supplied power, then delivered these data to the system. But the available power can be set manually by the user to keep the building consumed energy below a certain level because the limitation of the source or to save the energy. If the available energy not limited by the user the system will calculate it according to different circumstances, like the delivered power from the source, the storied energy in the batteries, and the weather prediction for the next two days.

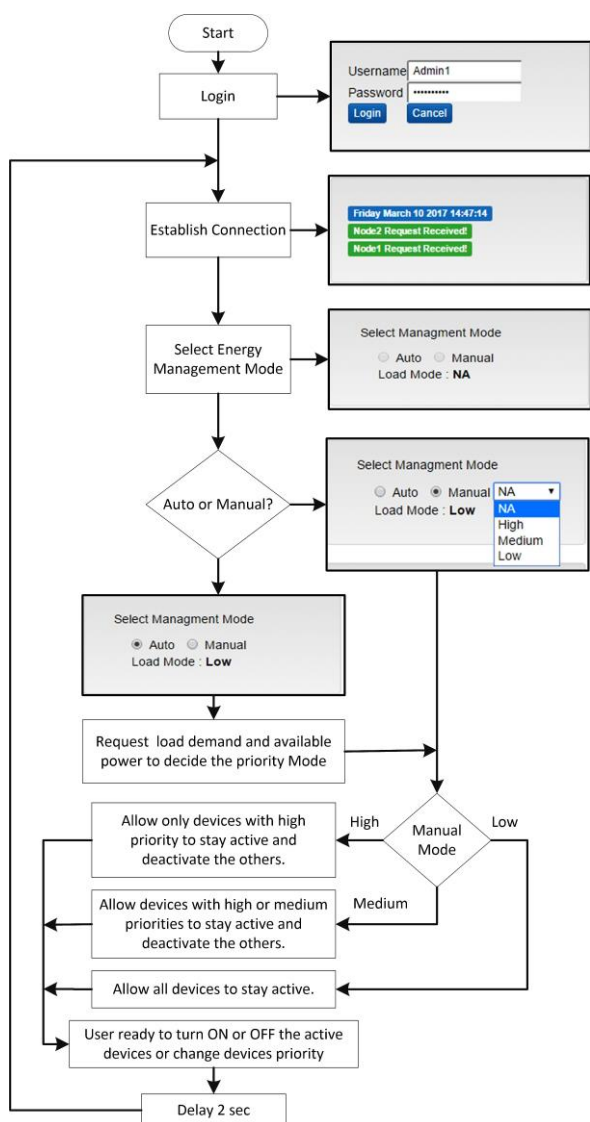

Figure 2. Website Flowchart.

Adopted Software

The website adopts many web design languages include a Java script to make the user fully controlled and monitoring data of many client nodes of the devices which is used a NodeMCU. A brief list of the used software with their duties is shown in Fig.3:

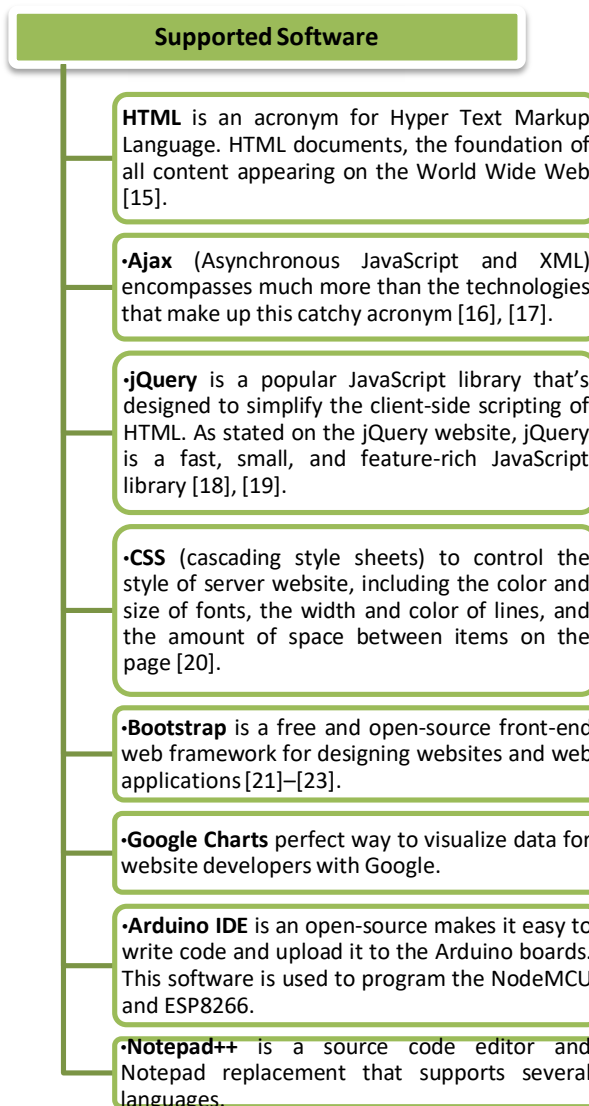

Figure 3. Adopted Software.

Energy Management Modes

Two modes are adopted by the system to manage the energy consumption, automatic and manual mode. In the automatic mode, the system has the authority to manage the power consumption based on a decision-making algorithm which will explain in detail in this article. But in the manual mode, the user will set the level of the power consumption, and the system will try to keep the consumed energy below the setpoint. Both modes, have three levels of priorities, high, medium and low priority.

Each device in the building has a different priority for the user, when the system is started, the user must schedule the priority of every device, otherwise they will have a high priority level. The three priority levels can be briefly described as the following:

- High priority level activates only devices with high priority.
- Medium priority level activates devices with high or medium priority.
- Finally, low priority level activates all devices.

In general, the level of priority at the auto mode will set according to the available power (AP) and demand of power (DP) as in Eq.1. System activates devices, according to their priorities and the load status, which could be Normal, critical, or Over load. Over load status make the system at high mode, critical load status at medium mode, and finally a normal load status at low mode.

Fig.4 shows an example of the power status in a specific power available and power demand, the demand of power in this case is (18.5 kWh) which is 82% of the available power, less than 85% for that the load considering as a normal load.

$$LoadStatus(AP, LD) = \begin{cases} Overload & LD > 90\%AP \\ CriticalLoad & 85\%AP \leq LD \leq 90\%AP \\ NormalLoad & LD < 85\%AP \end{cases} \quad (1)$$



Figure 4. Power status, AP, and LD example.

Electronic Circuit Design

The presented system can handle many nodes as much as the Wi-Fi router can handle, but it is tested to manage only three. Nodes must use a static internet protocol (IP) to avoid IP conflicts, this can be achieved easily by using a fix IPs in the Wi-Fi router according to the devices MAC address. Fig. 5 shows how to manage these two nodes which have two local IPs (192.168.50.136) and (192.168.50.138). Node1 controls four buttons with different IDs and priorities, but Node2 controls only two devices, but it is import to know that number of nodes and connected devices is a matter of the design requirement. The designed system uses ESP8266 (ESP-01 or ESP-12), according to the suggested number of the devices, and analog signal feedback.

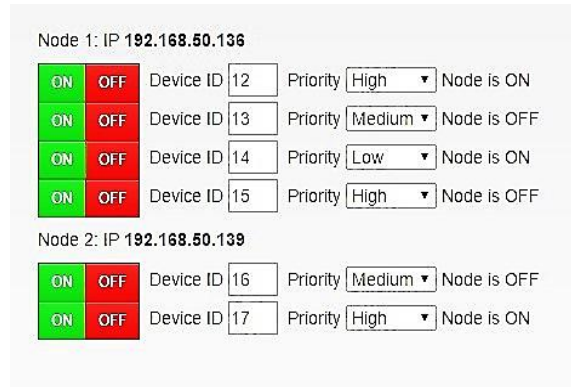
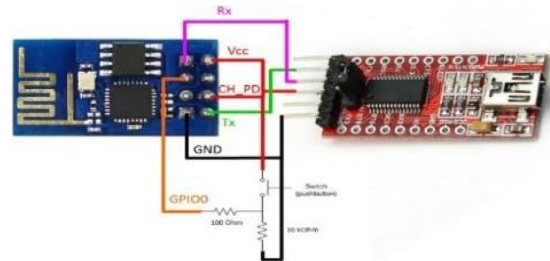

Figure 5. Device Manager.

The ESP8266 is a low-cost Wi-Fi chip with full TCP/IP stack and MCU capability, *Espressif Systems*. For the small node, which control two devices ON and OFF, ESP8266 ESP-01 is enough, but for the nodes that need to control more than two or need to read an analog sensor, it's required to use ESP8266 ESP-12 as NodeMCU.

ESP8266 ESP-01 needs to be programmed using FTDI board and with the help of Arduino IDE. This *FTDI* card connected as shown tin the Fig. 6 and it worked perfectly. The system also required a wireless router which can cover all the building. This router required to let the computer communicate with all the nodes. In case of big or multi store building that cannot be cover with one router, it possible to using more routers or make the ESP8266 work as a gateway to repeat the Wi-Fi signal [19], and cover the whole building as adopted in this design.



(a) Programming Adapter schematic.



(b) The implemented programming adapter.

Figure 6. The ESP8266 ESP-01 Adapter.

It is also required more electronic components to drive the device by the node. These components include ULN2003A or transistors, relays, LEDs, resistors, a 12V power supply, and OLED which is an optional. Fig. 7 present the driver schematic and the implemented circuit.

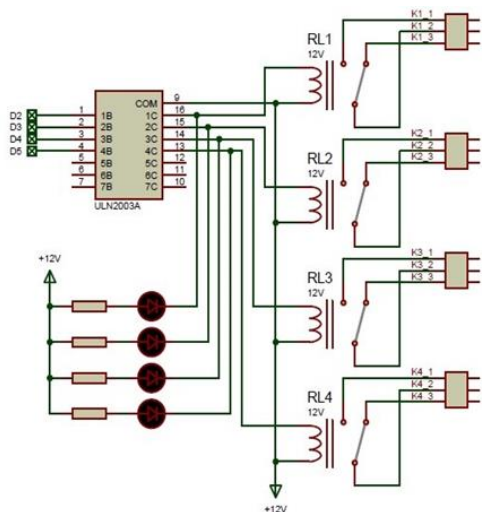

(a) Driver schematic.

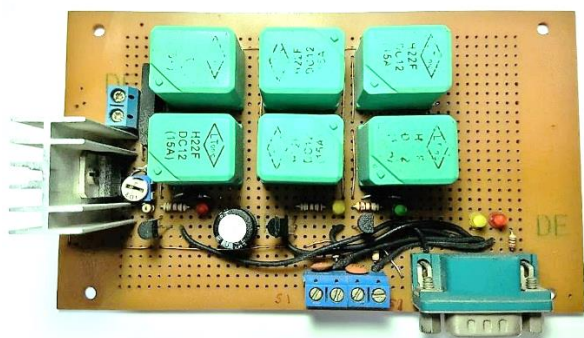

(b) The implemented driver.

Figure 7. Devices Drive circuitry.

System Implementation

The system is implemented, tested and worked as planned. For testing the website, the *Manual Mode* activated by selecting the *Manual Mode* as in Fig. 8 and the system priority level set to be *High*. Then the priority of each device has been set as shown in Fig. 9.

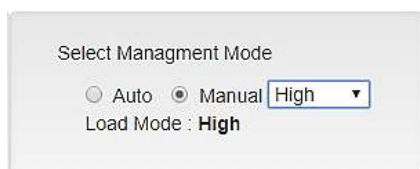

Figure 8. Mode Selection.

Since the energy management mode is *High*, so it is obvious that at Node 1 (device 13, Medium Priority),

(device 14, Low Priority), and at Node 2 (device 16, Medium Priority) are deactivated and turned OFF by sending a request for these nodes to turn them OFF.

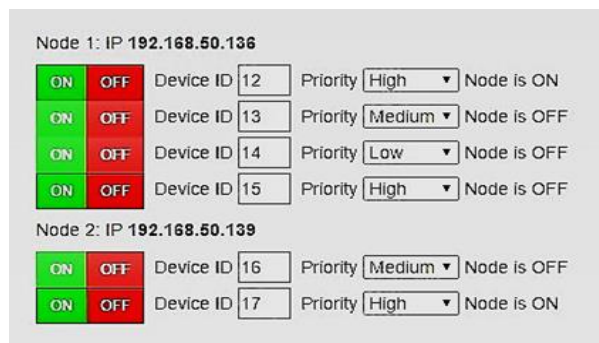

Figure 9. Devices activation response for High Level Manual Mode.

The website is programmed to send periodically request for each node to read the status of each device and that is so important in case if the website is refreshed. It's also reads all the available sensors and graphic them on the website, for example the website displays the available power and the demand load, which measured from a node that responsible for measuring these data as shown in Fig.10.



Figure 10. Monitoring of the Available Power and Load Demand.

At the left top corner of the website the time and date are displayed, they used as timestamp for the all saved data, the data includes all the devices' statue, sensors' reading, and all the events that happen periodically for evaluation purposes. The system used ESP8266 ESP-01 and ESP-12 according to the building's requirements, and number of devices and sensors connected to each node. Fig.11 shows a prototype for one of the nodes that measures and displays the load demand of the node. It also used to route the data to the out of reach nodes as required. The two presented LEDs are representing two devices for the hardware simulation purpose. The OLED used to display any required data, here it used to display the measured data and local time. Snapshots are taken from the displayed data, such as local time in Fig.12.

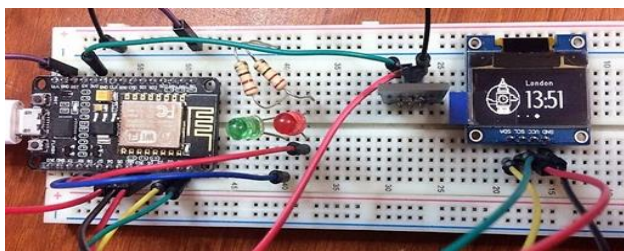

Figure 11. Prototype for ESP8266 ESP-12 Node.

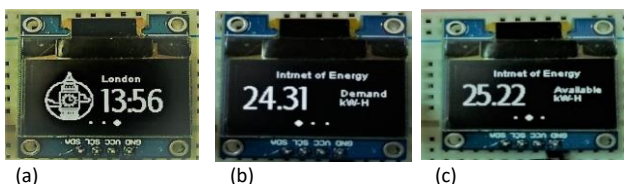

Figure 12. OLED Screen Presentation for Node 2. (a) Local Time, (b) Power Demand, (c) Available Power.

The Server website is built with aided of a “Notepad++”, HTML language is used for the main structure, Ajax used to scan all the node based on their internet protocol (IP), every 1 second. For example, to communicate with a device, it required to know it node IP address and its ID. The IP address is a static here for node#1 and equal to “192.168.50.136:1000”, So Ajax will use that IP as a uniform resource locator (url) to call that node.

```
var url1 = "http://192.168.50.136:1000";
$.ajax({
  url: url1,
  data: {'P': device1},
  dataType: 'jsonp',
  crossDomain: true,
  jsonp: false,
```

Google charts is used to display the load graph and the code is written as below:

```
google.load("visualization", "1", {packages:["corechart", "line"]});
google.setOnLoadCallback(drawChart);
var data;
var chart;
var options = {
  title: 'Load Curve',
  hAxis: { title: 'Time(s)',
  vAxis: {title: 'kW-H' }
};
```

Fig. 13 shows the complete website while it detecting two nodes, it also shows that the system in the Auto Mode and the load is normal.

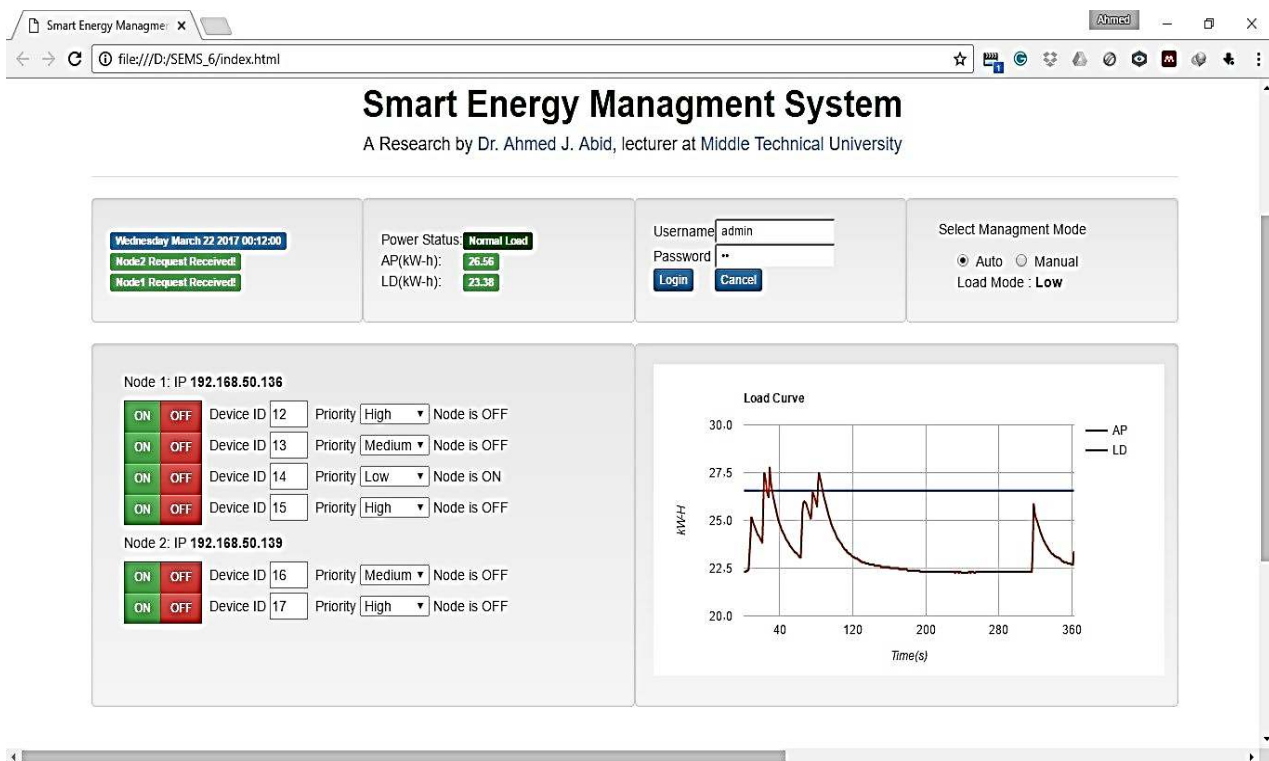

Figure 13. Designed Website.

Result and Discussion

As a case study, seven devices have been used with different load in watt and a scheduled priority based on the time of the day as shown in Table 1. Every device has difference running hours and it is obvious that the priority levels for the same device could be different. For example, device#1 has a high priority level at (10:00-17:00), otherwise it has a medium priority. Device# 4 has a high priority at any time, and so on. These data must have filled by the user and it will be used by the energy manager.

The devices' load may be fixed or slightly variable according to its specification and status, for that the system uses a power sensor, as shown in Fig. 14, to measure the instantaneous consumed power for each device, in case of the device has a constant wattage, it will be optional. Daily load and priority schedule are shown in Fig. 15 for this case study, it shows that the predicted low, medium, and high priority load will be maximum 3.07 kWh, 2.77 kWh, and 1.485 kWh repeatedly.

The term of available energy is a matter of the user permissible, instantaneous consumed energy, stored energy and the weather prediction for the next two days, but it is basically evaluated according to the following:

Load Evaluation

To evaluate the expected load the following steps, need to consider:

1. Measure the maximum energy required per day. According to the case study the expected maximum load per day is 3.07 kWh.
2. The stored energy must back up the load for more than two days, let consider that the stored energy can handle the load for two days (2×3.07kWh= 6.14 kWh).
3. If we consider that the energy will power load at the same time of charging, that make the source energy equal to the load energy plus the storage charging energy (3.07kWh+6.14 kWh= 9.21 kWh).
4. In case of a solar panels are power the building with panel energy equal to 250W and average day length



Figure 14. AC Power Sensing Device.

Devices								Low Priority kW-h	Medium Priority kW-h	High Priority kW-h
Node ID	112	113	114	115	216	217	218			
Power (W)	35	150	1100	225	300	60	1200			
Time										
1:00								3.07	0.32	0.285
2:00								3.07	0.32	0.285
3:00								3.07	0.32	0.285
4:00								3.07	0.32	0.285
5:00								3.07	0.32	0.285
6:00								3.07	0.26	0.225
7:00								3.07	0.26	0.225
8:00								3.07	0.26	0.225
9:00								3.07	0.56	0.525
10:00								3.07	0.56	0.56
11:00								3.07	0.26	0.26
12:00								3.07	0.26	0.26
13:00								3.07	0.41	0.26
14:00								3.07	0.41	0.26
15:00								3.07	0.41	0.26
16:00								3.07	0.41	0.26
17:00								3.07	2.71	1.425
18:00								3.07	2.77	1.485
19:00								3.07	2.77	1.485
20:00								3.07	0.47	0.285
21:00								3.07	0.32	0.285
22:00								3.07	0.32	0.285
23:00								3.07	0.32	0.285
0:00								3.07	0.32	0.285

Figure 15. daily Load and priority schedule.

5h, the total panel required is equal to (9.21 kWh / 5h= 1.842kW), and the number of the required panel is equal (≈8 panels).

5. The stored energy is (6.14kWh), if a 50% deep discharging are considering to protect the batteries, the battery capacity will be (6.14kWh/0.5=12.28kWh).
6. To calculate the number of the batteries, it required to choose the battery voltage, if 48V is selected the total Ampere – Hour = 12.28kWh/48V≈ 256 Ah). If a 12V 90A battery is selected, the number of the battery set is (256/90=2.84 ≈3 set of batteries each

Table 1. Selected Devices for Testing Purpose.

Device Name	Load (W)	Scheduled Time	Running Hour per Day	Energy Consumption (kWh/day)	Priority @ Scheduled Time	Normal Priority	Node Number	ID Number	
Device 1	35	10:00 - 17:00	7	0.245	High	Medium	1	12	
Device 2	150	13:00 - 21:00	8	1.2	Medium	Low	1	13	
Device 3	1100	17:00 - 20:00	3	3.3	Medium	Low	1	14	
Device 4	225	Anytime	24	5.4	High	High	1	15	
Device 5	300	9:00-11:00	2	0.6	High	Low	2	16	
Device 6	60	6:00- 18:00	12	0.72	Low	High	2	17	
Device 7	1200	17:00 - 20:00	3	3.6	High	Low	2	18	
Power (kW-h/day)				15.065					

set has $48V/12=4$ batteries, So the total number of batteries will equal to $4 \times 3= 12$ Batteries.

Battery Evaluation

The battery state of charge is directly proportional to the open circuit voltage (OCV). For example, 4XS Power, open circuit voltage for 12V battery is slightly drop from (12.9V @ 100% charge) into (10.5V @ 0% charge), according to its data sheet [20]. For that the system depend on measuring the OCV to indicate the battery backup power.

Weather prediction

The proposed system checks periodically the weather condition online, it can check if the next two days are sunny, windy, etc. these data will used by the system for making a power saving decision. For example, if the next two days are cloudy (for PV system), it is notifying the user that the system will change the priority to HIGH. Same procedure flows with wind speed (for wind generator). Weather monitoring can be achieved thanks to many weather websites that support application programming interface (API) developer such "open weather map", and more. The web site gathering these data using the JavaScript code below:

```

<script>
function gettingJSON(){
document.write("jquery loaded");
$.getJSON("http://api.openweathermap.org/data/2.5/weather?q=Baghdad&APPID=37615fa75076dc05bc1bfea3ad86316b",function(json){document.write(JSO
N.stringify(json));
});
}
    
```

Decision making

The presented system offers measuring the building total load, the storied energy, and the predicted power for the next two days, according to equation 1. Fig. 16 present a flowchart describes how the system to select the priority level automatically.

The system will keep the load always below the available load at the auto mode, but it is only notifying the user for the urgent load at the manual mode. It is also running the devices back when the available power is increasing again, such as it is sunshine again or goes windy. Fig. 17 shows the coverage load at different priorities. The system shades the load when the available power

decreases. Finally, all the measured data will save into database to increase the accuracy of the system's prediction.

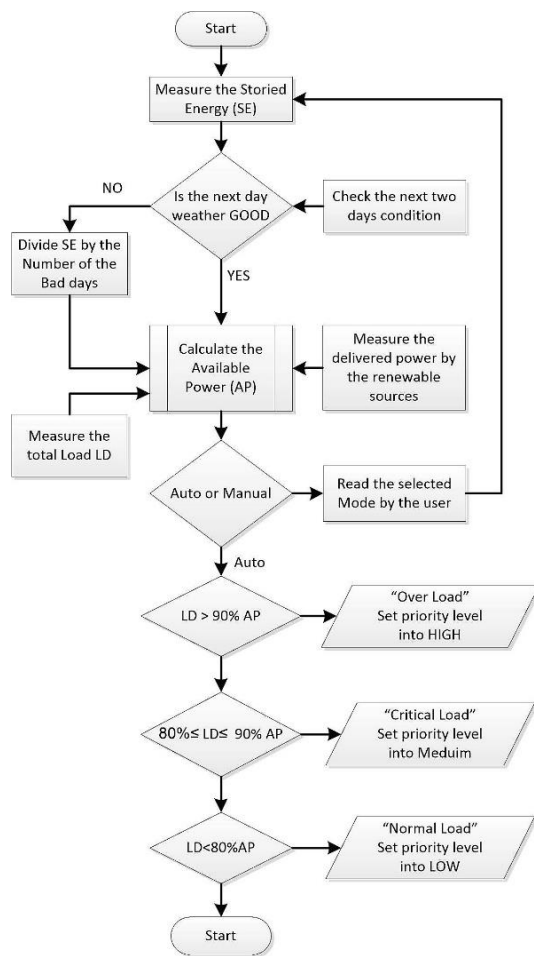

Figure 16. Decision making flowchart.

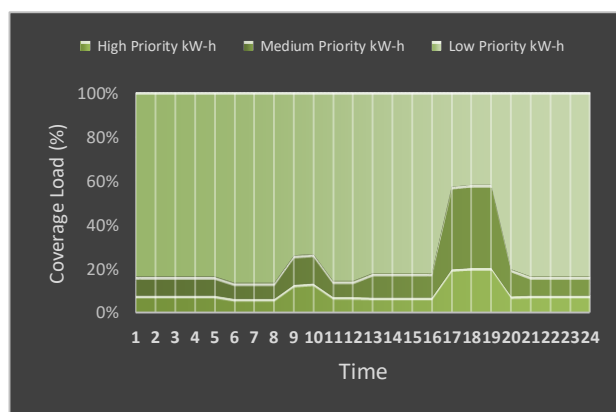

Figure 17. Coverage Load at difference priorities.

Conclusion

Internet of Energy is how to manage your energy consumption with limited resources without affect the quality of life as much as possible. The proposed system presents a low cost, reliable, efficient way to manage the

power consumption for a Wi-Fi covered building with wireless router with a decision-making system based on web design. The system offers fast response to recover the load shading caused by many reasons in the renewable energy source [21], power limited resources, or to save the consumption under a certain level to save the electricity bills.

The article main contribution can conclude as following:

- The Proposed system can solve the problems that face the grid-off building by managing the consumed power without affecting the quality of life and under supervision of the user.
- It is saving the energy by reducing the unwanted load according to schedule.
- The system can keep the consumed energy under certain level to save the electricity bills.
- Since the system saves all the data periodically, it is possible to make an energy report for reviewing.

References

- [1] Y.-F. Wang, "Sustainable Cities: Advanced Technological Development Trends," *Int. J. Autom. Smart Technol.*, vol. 7, no. 2, pp. 33–35, 2017. doi: [10.5875/ausmt.v7i2.1462](https://doi.org/10.5875/ausmt.v7i2.1462)
- [2] D. W. C. Martinez and A. Y. Chua, "New Design and Automation Concept of an Energy-Efficient, Tertiary Building for Mixed-Mode Ventilation System," *Int. J. Autom. Smart Technol.*, vol. 7, no. 4, pp. 163–178, 2017. doi: [10.5875/ausmt.v7i4.1290](https://doi.org/10.5875/ausmt.v7i4.1290)
- [3] M. Sechilariu, B. Wang, and F. Locment, "Building integrated photovoltaic system with energy storage and smart grid communication," *IEEE Trans. Ind. Electron.*, vol. 60, no. 4, pp. 1607–1618, 2013. doi: [10.1109/tie.2012.2222852](https://doi.org/10.1109/tie.2012.2222852)
- [4] Y. Lu, S. Wang, and K. Shan, "Design optimization and optimal control of grid-connected and standalone nearly/net zero energy buildings," *Appl. Energy*, vol. 155, pp. 463–477, 2015. doi: [10.1016/j.apenergy.2015.06.007](https://doi.org/10.1016/j.apenergy.2015.06.007)
- [5] O. Vermesan *et al.*, "Internet of energy - Connecting energy anywhere anytime," in *Advanced Microsystems for Automotive Applications 2011: Smart Systems for Electric, Safe and Networked Mobility*, 2011, pp. 33–48. doi: [10.1007/978-3-642-21381-6_4](https://doi.org/10.1007/978-3-642-21381-6_4)
- [6] O. Vermesan and P. Friess, *Internet of things: converging technologies for smart environments and integrated ecosystems*. River Publishers, 2013.
- [7] C. Wei and Y. Li, "Design of energy consumption monitoring and energy-saving management system of intelligent building based on the Internet of things," in proceeding of *2011 International Conference on Electronics, Communications and Control*, China, Sept. 9-11, 2011, pp. 3650–3652. doi: [10.1109/icecc.2011.6066758](https://doi.org/10.1109/icecc.2011.6066758)
- [8] B. Zhou *et al.*, "Smart home energy management systems: Concept, configurations, and scheduling strategies," *Renew. Sustain. Energy Rev.*, vol. 61, pp. 30–40, 2016. doi: [10.1016/j.rser.2016.03.047](https://doi.org/10.1016/j.rser.2016.03.047)
- [9] D. Zhang, N. Shah, and L. G. Papageorgiou, "Efficient energy consumption and operation management in a smart building with microgrid," *Energy Convers. Manag.*, vol. 74, pp. 209–222, 2013. doi: [10.1016/j.enconman.2013.04.038](https://doi.org/10.1016/j.enconman.2013.04.038)
- [10] Y. Strengers and L. Nicholls, "Convenience and energy consumption in the smart home of the future: Industry visions from australia and beyond," *Energy Res. Soc. Sci.*, vol. 32, pp. 86–93, 2017. doi: [10.1016/j.erss.2017.02.008](https://doi.org/10.1016/j.erss.2017.02.008)
- [11] P. Padmanabhan and G. R. Waissi, "Cloud-based home energy management (hem) and modeling of consumer decisions," *Int. J. Smart Home*, vol. 10, no. 8, pp. 213–232, 2016. doi: [10.14257/ijsh.2016.10.8.21](https://doi.org/10.14257/ijsh.2016.10.8.21)
- [12] D.-M. Han and J.-H. Lim, "Smart home energy management system using IEEE 802.15. 4 and zigbee," *IEEE Trans. Consum. Electron.*, vol. 56, no. 3, 2010. doi: [10.1109/tce.2010.5606276](https://doi.org/10.1109/tce.2010.5606276)
- [13] J. Han, C.-S. Choi, W.-K. Park, I. Lee, and S.-H. Kim, "Smart home energy management system including renewable energy based on ZigBee and PLC," *IEEE Trans. Consum. Electron.*, vol. 60, no. 2, pp. 198–202, 2014. doi: [10.1109/icce.2014.6776125](https://doi.org/10.1109/icce.2014.6776125)
- [14] K. Baraka, M. Ghobril, S. Malek, R. Kanj, and A. Kayssi, "Low cost arduino/android-based energy-efficient home automation system with smart task scheduling," in proceeding of *Computational Intelligence, Communication Systems and Networks (CICSyN)*, Spain, June 5-7, 2013, pp. 296–301. doi: [10.1109/cicsyn.2013.47](https://doi.org/10.1109/cicsyn.2013.47)
- [15] B. Andrés, F. Alejandra, J. Miguel, S. Augusto, and W. Pedro, "Towards the Evolution of Smart Home Environments: A Survey," *Int. J. Autom. Smart Technol.*, vol. 6, no. 3, pp. 105–136, 2016. doi: [10.5875/ausmt.v6i3.1039](https://doi.org/10.5875/ausmt.v6i3.1039)
- [16] A. J. Abid, R. S. Ali, F. M. Al-Naima, Z. Ghassemlooy, and Z. Gao, "A new power line communication modem design with applications to vast solar farm management," *2013 3rd Int. Conf. Electr. Power Energy Convers. Syst. EPECS 2013*, no. 3, 2013. doi: [10.1109/epecs.2013.6713015](https://doi.org/10.1109/epecs.2013.6713015)
- [17] A. J. Abid, "Internet of Energy: A Design to Manage Energy Consumption for Limited Resources Building," *Int. J. Open Inf. Technol.*, vol. 5, no. 6, pp.

- 20–25, 2017.
- [18] D. B. Henningson and B. A. Purkey, "System and method for using solar power to supplement power in a dc electrical system." Google Patents, 29-Dec-2016.
- [19] I. Tripathi, "Wireless environmental parameters monitoring and sms alert system," in proceeding of *Information Technology (InCITE)-The Next Generation IT Summit on the Theme-Internet of Things: Connect your Worlds*, India, Oct. 6-7, 2016, pp. 166–171.
doi: [10.1109/INCITE.2016.7857610](https://doi.org/10.1109/INCITE.2016.7857610)
- [20] "XS Power Battery," 2018. [Online]. Available: <https://4xspower.com/support/faqs/>.
- [21] G. Yun, K. C. Yoon, and K. S. Kim, "The influence of shading control strategies on the visual comfort and energy demand of office buildings," *Energy Build.*, vol. 84, pp. 70–85, 2014.
doi: [10.1016/j.enbuild.2014.07.040](https://doi.org/10.1016/j.enbuild.2014.07.040)



©The Authors. This work is licensed under the Creative Commons Attribution-NonCommercial-NoDerivatives 4.0 International License.