

# Internet of Things in Agriculture to Revolutionize Traditional Agricultural Industry

Dr. Kirubanand VB<sup>1</sup>✉, Dr. Rohini V<sup>2</sup> and Laxmankumar.V<sup>3</sup>

<sup>1,2</sup>Department of Computer Science, CHRIST (Deemed to be University) Bangalore-560029

<sup>3</sup>SimplyTurn Tech, Hyderabad-500085

**Abstract.** Agriculture is familiarly called “Farming”. Agriculture is the basic art to cultivate food which is a necessary need to every living individual. Agriculture needs the practice of science for cultivating the soil factors and growing crops. In traditional farming, it includes more labor work and less yield quantity. This demerit can be overcome by the modern farming techniques which makes use of the advanced technology and focuses on maximizing the yield and maintaining the quality. Earlier the farmers used to figure out the type of the soil based on their suspicion and they would never think of the humidity, temperature, climatic condition and especially the level of water. IoT is trying to overcome all these factors by helping to assemble the information. This paper focuses on the soil moisture and soil type which lets the farmer know about the type of crops to be grown.

## 1 Introduction

Agriculture is the backbone of India. Food and food grains are essential for the livelihood. The demand for food is a challenging task for every being, as there is rapid climate change, extreme weather conditions and environmental impacts which impacts on farming practices. The ever-growing global population would touch around 9.6 billion by 2050[14,17]. So, to feed this immense population, the agriculture industry needs to embrace IoT. Smart IoT technology farming can help farmers minimise waste produced and increase productivity that can come from the amount of fertiliser used. So, Smart Farming is essentially a hi-tech food growing device [6, 7,9,11]. This application of modern ICT (Information and communication technologies) has been introduced into agriculture.

Nitrogen Phosphorus and Potassium (NPK) are important to the plants. Plants need these to grow healthy. The plant will fail without any one of the nutrients. The leaf growth in the plant is taken care of nitrogen. The root, flower and fruit development are taken care by Phosphorous. The overall plant growth is taken care by Potassium in a good way. The farmers should know the NPK value of the plant and fertilise them accordingly. High Nitrogen is required for Leafy vegetables. Vegetable and fruit plants should be rich in Phosphorous. Potassium is needed for all type of plants. Based on the purpose of the plant, the needed nutrients should be given to him to yield well. For flowering plants, it is advisable to give fertilisers rich in Phosphorous to give good blooms. Agriculturist normally recommend the fertilisers based on the NPK value of the soil.

Along with NPK, to the soil the soil should be tested for its acid and alkaline properties. The manure should be given to the soil as the microbes decompose the material, releasing CO<sub>2</sub> which forms carbonic acid. Humus decomposition releases organic acids also, which is good manure for the plants along with the cow dungs and hen waste. Natural organics like plant waste, animal waste and human waste are good for the soil, to become rich in nutrients.

Elemental sulfur can be given to the soil, which decomposes with Water and Oxygen and forms the nutrient for the soil in the presence of sulfur-oxidizing bacteria. Iron and aluminum, react with water to produce Hydrogen, which is a good manure for the soil, to improve the plant growth. By applying acids to the fertilisers given to the plants thru the soil, reduces the pH content of the soil, which helps in the growth of the plant. Ammonium is liquefied by the bacteria present in the soil and give nitrate and hydrogen ions to ensure the fertility of the soil.

Soil with carbonates or lime are very resistant to acidify, as their pH is very high. The soil needs a low pH range to grow the plants in a good condition. The advice of not using plastic in the soil is same as it does not degrade, in turn, which makes the soil to degrade and not feasible to grow plants in the soil. pH is an important factor for plant growth. The level of pH should be maintained according to the type of the plant to have high yield. The paper mainly concentrates on the pH of the soil to ensure the plant growth in a healthy way.

✉Corresponding author: [kirubanand.vb@christuniversity.in](mailto:kirubanand.vb@christuniversity.in)

Vegetable plants like carrot, beetroot, tomato, brinjal, Ladies finger, green leaves, cucumber, grows well in the field, where the pH of the soil is between 7 and 8. Coffee, tea, olive, orange, arrowwood, black berry are the alkaline tolerant plants, which grow in a hilly area, where the alkaline content is more in the soil and of course the pH of the soil is more.

The papers is divided into parts as follows: introduction, System analysis, System Design, Test plan, Experiment, Results and conclusion.

### 1.1 IOT Technology benefiting today's modern farming Industry

Precision farming is a process or a practice that makes the farming procedure more accurate and controlled for raising livestock and growing crops [17, 18]. It has been one of the most popular IoT applications in the agricultural sector in recent years and a large number of companies have started using this technique around the world [9-12]. Agricultural drones are a very good example of Agriculture for IoT applications. Today, agriculture has become one of the main industries in which drones can be integrated. There are two types of drones, namely- Ground-based and Aerial-based.



**Fig. 1.** Use of IOT in agriculture

Drones are used in agriculture for various reasons crop health assessment, irrigation planting, and soil analysis. The drone technology will give a cutting-edge makeover to the agriculture industry by utilizing systems and arranging the continuous information assortment [18]. The drone innovation will give a bleeding edge makeover to the horticulture business. Information is gathered by the drone like: helpful bits of knowledge on different factors, for example, plant tallying, plant wellbeing lists, plant tallness estimation, and furthermore. Fig. 2 depicts the applications of IOT in industry.

#### 1.1.1 Livestock Monitoring

It helps the farmers to collect data regarding the location, wellbeing, and health of cattle's. It helps

Farmers to gather information with respect to the area, wellbeing, and strength of their cattle [15,17]. The information encourages them in distinguishing the state of their cattle ie. Discovering the cattle are sick and preventing the spread of the illness to the whole cattle. The sensors empower farmers with more clarity to focus. [8,10-13]

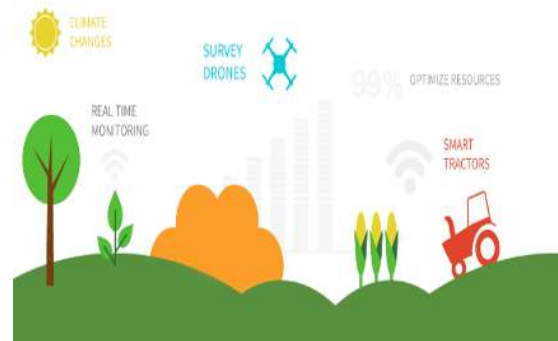

**Fig. 2.** IOT Applications in Industry

Figure 2 depicts the Applications of IOT in the various industries. It depicts the versatility of the IOT in the industrial purposes.

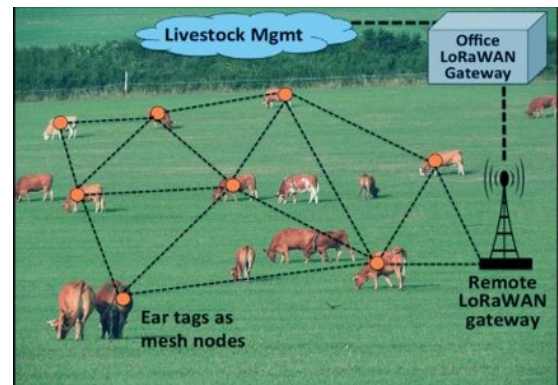

**Fig. 3.** LoRa & LPWA

LoRa WAN (Low power Wide Area (LPWA) networking protocol de-signed to wirelessly connect battery operated 'Things' to the internet [10, 15, 19]. **LoRa**, is the physical layer or the (wireless) modulization which creates the long range communication link.

Greenhouse farming, technique enhances the yield of crops, vegetables, fruits and much more in the soil. Greenhouses control environmental parameters in two ways: Manual intervention and proportional control mechanism. In these techniques, different sensors are used to measure the environment as indicated by the plant necessity and are utilized for control-ling the environment in a smart greenhouse. [8,18]

In this process, the Cloud Server helps in the handling of information and it applies control activity [10,16,17]. Therefore, farmers get benefited with minimal and almost no manual intervention. Challenges for Urban people growing their own vegetables are:

- Lack of space with adequate sunlight
- Lack of availability: While no one is there in particular location for a long period of time
- Lack of farming knowledge

### 1.1.2 Hydroponic types



**Fig. 4.** Nutrient Film Technique (NFT)

NFT, suitable for leafy Vegetables, is depicted in Figure 4.

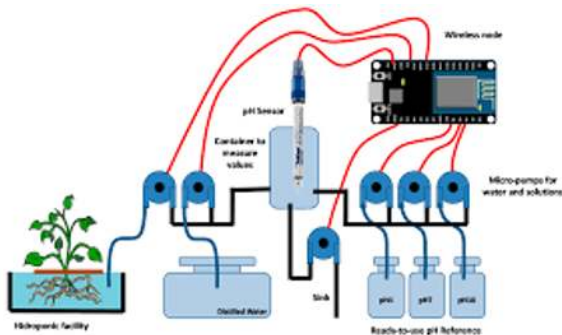

**Fig 5.** Hydroponic Precision Farming

In Hydroponic Precision Farming, the auto calibrated pH sensor is placed, to read the soil fertility and the LCD display to display the results. The Hydroponic Precision Farming system is depicted in Fig 5.

### 1.2 Soil Fertility using IOT

Adequate manure can assist plants creating great yields in good amount, to improve the quality and number of harvests, estimation of N (nitrogen), P (phosphorous) and K (potassium) substance of soil is important to decide how much compost is expected to add to the soil to build crop fruitfulness [1,2]. The pH sensor created can distinguish the degrees of NPK in the soil and afterward appropriately required composts can be added to the soil. These three component supplements advance the development of the plant in various manners - Nitrogen advances the development of leaves and vegetation, Phosphorus advances root and development and Potassium advances blossoming, fruiting and keeps guidelines of supplement and water in the plant cell [3].

Soil can be acid, neutral or antacid, as indicated by its pH value. [4]

pH strongly impacts the accessibility of supplements and the nearness of microorganisms and plants in the soil. For instance, growths incline toward acidic conditions though most microorganisms, particularly those providing supplements to the plants, have an inclination for tolerably acidic or slight antacid soils. Truth be told, in unequivocally acidic conditions, nitrogen fixing and the mineralization of vegetable lingering is diminished. Plants ingest the supplements broken up in the soil water and the supplement dissolvability relies to a great extent upon the pH esteem [5]. pH of the soil is measured by the hydrogen content in the soil. which check the acidity of the soil. Consequently, the Dirt can be corrosive, nonpartisan or soluble, as indicated by its pH esteem.[4] Most plants lean toward a pH run from 5.5 to 7.5; yet a few species groups incline toward progressively corrosive or soluble soils [12]. However, each plant re-quires a specific scope of pH, for ideal development. Each plant needs components in different amounts.

## 2 System Analysis

### 2.1 System Architecture

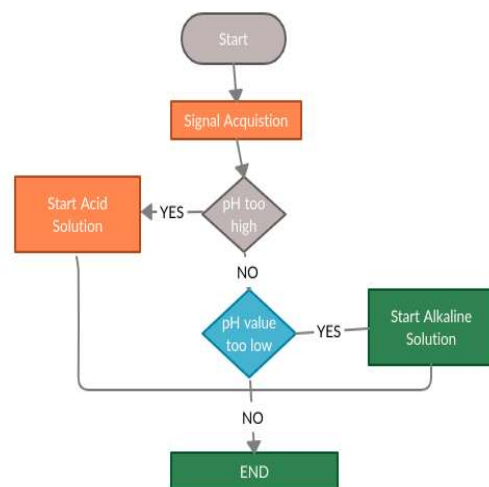

**Fig. 6.** Proposed System Architecture

The proposed architecture for the system is depicted in Fig. 6. The pH sensors given in the soil gets the information and process the signals. The pH of a solution measures the hydrogen ion concentration, which in turn is a measure of its acidity. Pure water dissociates slightly into equal concentrations of hydrogen and hydroxyl (OH<sup>-</sup>) ions.

The best pH for plants is typically between 5.5 and 6.5, though some plants may need more acidic or more alkaline soils. The soil nutrients are strongly bonded with the pH of the soil, where pH controls the efficiency of the fertilizers available in it. Additionally, soil nutrients are tied strongly with pH of soil; in fact, pH

control maximizes the efficiency of fertilizers by controlling nutrient available in it. pH of soil affects the bacteria, virus and harmful toxic elements, present in the soil. It is a notification for the Agriculturist to know about the health of the soil.

The pH sensor functions as a soil pH meter, which works for calculating the pH in the soil. The Arduino microcontroller acts as a controller, receiver and processor, which gets the input from the soil and receives the input and processes it according to the reading of the pH sensor.

The pH range in soil is given in table 1, which are acidic in nature. The level indicates the acidity of the soil and it can be balanced by adding the required nutrients.

**Table 1.** pH range in soil

Denomination	pH range
Ultra acidic	< 3.5
Extremely acidic	3.5–4.4
Very strongly acidic	4.5–5.0
Strongly acidic	5.1–5.5
Moderately acidic	5.6–6.0
Slightly acidic	6.1–6.5
Neutral	6.6–7.3
Slightly alkaline	7.4–7.8
Moderately alkaline	7.9–8.4
Strongly alkaline	8.5–9.0
Very strongly alkaline	> 9.0

As the lime contents are more in the alkaline rich soil, it is not suitable to grow plants and do vegetation in that type of soil. Alkaline rich soil can be treated by giving them rich manures, but it is treatable in some cases and not in other cases based on their environment. If the alkaline content is created based on the calcium carbonate rich, it is difficult to cure them. Rather than, the soil can be used for some other purpose like making lime stone etc.,

If the soil is rich in pH, based on the denomination given in the table 1, the Acid solution is started to give to the soil, to increase the fertility of the soil. Giving the only needed nutrients to the soil to ensure it will be good for the soil. If the soil is high in pH, add pulverized limestone to the soil. Limestone acts as neutralizer for the acidity of the soil. It consists of calcium and magnesium carbonate or calcium carbonate.

If the soil is poor in pH, alkaline solution is given to the soil for fertilizing. Chemicals like Sphagnum peat, elemental sulfur, aluminum sulfate, iron sulfate, acidifying nitrogen, and organic mulches will help the soil to be rich in nutrients. This enhances the fertility of the soil and gives good yield to the farmers.

An excellent way to enrich the pH in small areas is to give high nutrient coco peat for the plants, which are basically rich in NPK. Adding Sphagnum peat to the small garden area will be economical than to a bigger area of land, to increase the pH of the soil in it.

## 2.2 Requirement Specification

Some of the system requirements for the experiment are: Arduino Uno Board, pH Sensor Board, pH sensor electrode, Water level sensor (Probs), and Serial Monitor. Table 2 specifies the requirements used for the experiment.

**Table 2.** Requirement specification for the experiment

Component	Units Used	Specifications
Arduino Board	1	UNO
pH Sensor Board	1	Provides temperature Analog Output (LM35) and Digital Output (DS18B20)
pH sensor electrode	1	Glass which senses the hydrogen ion concentration

## 3 System Design

Defining the elements plays a vital role. Designing consists of numerous elements they are: architecture design, specifying the modules, components and most importantly the way of approach



### 3.1 Modular Specification

Module 1 – Collecting different samples of the soil and extracting water out of it, so that the pH of the water can be tested in different types of soil water collected.

Module 2 – This module determines the pH value of the soil by pH sensor electrode.

Module 3 – This module determines the NPK value of the soil by using the pH values determined

### 3.2 Component Description

#### 3.2.1 Arduino Uno Board

The Arduino UNO is a microcontroller board and is a free open source available for experiments in small scale. Sets of digital and analogue input / output (I / O) pins are given on the frame. It is based on the ATmega328P (datasheet). It has 14 digital in-put/output pins, 6 analog inputs, a 16 MHz ceramic resonator, a USB connection, a power jack, an ICSP header and a reset button. The board has 14 computerised pins, 6 analogue pins, and is programmable using a form B USB cable with the Arduino IDE. It acknowledges the voltage which ranges from 7 and 20 volts [17, 20].

#### 3.2.2 pH Sensor Board

The analog pH sensor, designed for Arduino controllers can be utilized as a socket and plays a role for measuring pH estimation with no extra circuit. It consists of a LED which works as the Power Indicator, a BNC connector and PH2.0 sensor to interface. To utilize it, we simply associate the pH sensor with the BNC connector, and attach the PH2.0 interface into the simple information port of any Arduino controller.[20]

#### 3.2.3 pH Sensor Electrode

The pH electrodes are made of a special compositional glass that detects the concentration of hydrogen ions. This glass is usually made of alkali metal ions in the research solution that undergo an ion exchange reaction with the hydrogen ions to produce a potential difference. The bulb is filled with an acid solution (e.g. 0.1 molL<sup>-1</sup> HCl). [4,20]. Fig 7 shows a pH sensor Electrode.

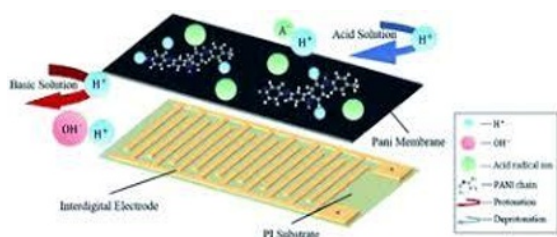

Fig. 7 pH sensor Electrode

#### 3.2.3 Serial Monitor

The serial monitor is a bridge between Arduino board and the computer. It is used for sending and receiving the text messages, correcting the errors and to pass the commands from the system to the board using the keyboard. [4, 20]

### 4 Test Plan

To make sure that the pH sensor electrode is working fine and the pH values of the soil are getting determined.

- To determine the correct pH values of the soil as the determination of the NPK levels in the soil depends on the levels of the pH value of the soil.
- To ensure that pH value of the soil lies between the ranges of 0-14 as the standard scale of pH is from 0-14.

#### 4.1 Testing Environment

A testing domain is a setup of soft-ware and hardware for the testing groups to execute experiments. As such, it facilitates execution of experiments with optimised facilities, applications and network. Test Environment comprises components that help test execution with programming, equipment and system design.

##### 4.1.1 Factors for designing Test Environment are as follows

- Determine if the test condition needs documenting so as to take back-ups.
- Check the network configuration.
- Identify the necessary server operating system, databases and other components.
- Identify the number of licenses required by the test group.
- The area from where soil belongs to.
- The pH level of the soil from which NPK levels can be determined

The nutrients that are required by crops in the largest amounts are N, P and K, which are important for their growth.

#### 4.2 Test Plan

The test plan is that the project should be checked for all types of soils. The pH level determined from the soil water can be used to determine NPK level/values of the soil. By determining the NPK level of the soil, we can actually understand the fertility of the soil and accordingly crops can be grown on the field.

#### 4.3 Test Cases and Results

The tests when performed on different types of soil depicted different results. Basically, we cannot predict the pH level of soil as soil differs from region to region. But most commonly, it is found as-

SOIL ACIDITY	NITROGEN	PHOSPHATE	POTASH	FERTILIZER WASTED
Extremely Acid-4.5pH	30%	23%	33%	71.34%
Very Strong Acid-5.0pH	53%	34%	52%	53.67%
Strongly Acid-5.5pH	77%	48%	77%	32.69%
Medium Acid-6.0pH	80%	52%	100%	19.67%
Natural-7.0pH	100%	100%	100%	00.0%

Fig. 8. NPK balance sheet

## 5 Experiment

### 5.1 Sketch

Sketch is a file consisting of the Arduino IDE. Pre-1.0 sketches were saved by Arduino Software (IDE) with the .pde extension. A minimum programme in Arduino C / C++ consists of two functions only:

#### setup():

The setup() function is used when the Sketch starts or resets. This features is enhanced to set or reset the features names. It is utilized to introduce the factors, information and change the modes of the pins and utilise different libraries used in the sketch.

#### loop():

By the completion of the setup() work, the loop() Study is regularly carried out in the central curriculum. It monitors the reading until the work is completed or reset.

The Arduino sheets contain a light-producing diode (LED) and a current restricting resistor associated between pin 13 and ground, which is useful for the component testing some features of the program correctly.. This program is generally stacked into another Arduino board by the maker

### 5.2 Algorithm

The algorithm for the proposed architecture is depicted below:

- The sensors placed in the field senses the features. (signal Acquisition)
- System checks the pH value.
- If it is high start the Acid solution for the field/plant
- If it is low, start the Alkaline Solution.
- Stop

### 5.3 Procedure

The procedure to measure the pH in the soil was done as follows:

- i)

- Take a jar of 1 liter. Put the soil for  $\frac{3}{4}$  of the jar. Add distilled water for the remaining space in the jar
- Cap jar and shake the soil vigorously a few times.
- Let mixture stand 10 minutes to dissolve the salts in the soil.
- Calibrate the pH sensor with a pH 7 and a pH 10 buffer solution.
- Remove the cap and place the pH sensor into the wet soil slurry.
- Measure pH and record measurement.



Fig.9 pH sensor connected with LCD

The figure 8 depicts the set up used to connect the ph sensor with the LCD. The sensor senses the pH value in the soil and is displayed in the LCD for the easy reference of the use. This helps the user to know the fertility of the soil.

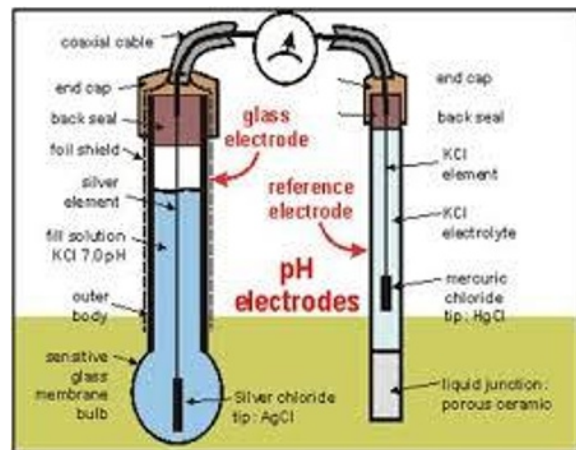

Fig. 10 working of the pH sensor

### 5.4 Output

If the same soil sample tested twice gives a difference of 0.5, then it is a good technique to be used and provides a high confidence in results. The output displays the values of the pH which is tested over the soil water. Firstly the output values shown on the serial monitor and which is accompanied with the average value. It is being displayed on the LCD.



**Fig. 11.** Output in LCD Display

Figure 10 depicts the value in the pH sensor. Based on the value in the LCD display, the owner can act accordingly.

## 6 Conclusion and Future Scope

By checking the NPK in the soil of a land can give an accurate result on the soil. The functioning of the soil can be determined. It is advisable to use the vegetation based on the pH value of the soil to yield a good result and crop. The vegetation chart based on the acid value is available with the local people of that area or the agricultural research office in that area. Typically, these major nutrients are the first that the soil requires. Plants require huge quantities to expand and to live. Furthermore, these elements can naturally leach from the soil with the weather particularly during rainy or hot seasons.

The development of new methods of improving crop yield and handling are made possible with the help of IoT technology. In addition to targeting traditional, large-scale farming operations, IoT-based smart farming technologies could be new levers for uplifting other and or popular agricultural patterns as organic farming, family farming, particular livestock and/or crops and enhancing highly transparent agriculture. It helps the soil to be rich in nutrients and the farmers also to be benefited.

## References

1. N. Singh and A. Shaligram, "D. NPK Measurement in Soil and Automatic Soil Fertilizer Dispensing Ro-bot", *International Journal of Engineering Research & Technology*, vol. 3, no. 7, pp. 635-637, 2014.
2. Y. Kulkarni, K. K. Warhade and S. Bahekar, "Primary nutrients determination in the soil using UV spectroscopy", *International Journal of Emerging Engineering Research and Technology*, vol. 2, pp. 198-204, 2014.
3. D. Q. Huo et al., "Recent Advances on Optical Detection Methods and Techniques for Cell-based Micro-fluidic Systems", *Chinese Journal of Analytical Chemistry*, vol. 38, no. 9, pp. 1357-1365, 2010.
4. D. V. Ramane, S. S. Patil and A. Shaligram, "Detection Of Npk Nutrients Of Soil Using Fiber Optic Sensor", *International Journal of Re-search in Advent Technology (E-ISSN: 2321-9637) Special Issue National Conference "ACGT*, pp. 13-14, 2015.
5. Ashwini, Humaira Hameed, Kavya Karkera, Neha Sherigar; Mr. Avinash N J "Soil Nutrient Tester and Air Purification System", 2019 *International Journal of Engineering Research & Technology (IJERT)* ISSN: 2278-0181.
6. Ayaz, Muhammad & Uddin, Ammad & Sharif, Zubair & Mansour, Ali & Aggoune, elHadi. (2019). *Internet-of-Things (IoT)-Based Smart Agriculture: Toward Making the Fields Talk*. IEEE Access. PP. 1-1. [10.1109/ACCESS.2019.2932609](https://doi.org/10.1109/ACCESS.2019.2932609).
7. Verdouw, Cor & Wolfert, Sjaak & Tekinerdogan, Bedir. (2016). *Inter-net of Things in agriculture*. CAB Reviews. 11. 1-12. [10.1079/PAVSNR201611035](https://doi.org/10.1079/PAVSNR201611035).
8. Wolfert, S., Ge, L., Verdouw, C., & Bogaardt, M.-J. (2017). *Big Data in Smart Farming – A review*. *Agricultural Systems*, 153, 69–80. <https://doi.org/10.1016/j.agsy.2017.01.023>
9. *Review of Internet of Things towards sustainable development in agriculture*. (2020). *Journal of Critical Reviews*, 7(03). <https://doi.org/10.31838/jcr.07.03.28>
10. Stočes, Michal & Vaněk, Jiří & Masner, Jan & Pavlík, J.. (2016). *Internet of Things (IoT) in Agriculture - Selected Aspects*. *Agris on-line Papers in Economics and Informatics*. VIII. 83-88. [10.7160/aol.2016.080108](https://doi.org/10.7160/aol.2016.080108).
11. S. Jaiganesh, K. Gunaseelan and V. Ellappan, "IOT agriculture to improve food and farming technology," 2017 *Conference on Emerging Devices and Smart Systems (ICEDSS)*, Tiruchengode, 2017, pp. 260-266, doi: [10.1109/ICEDSS.2017.8073690](https://doi.org/10.1109/ICEDSS.2017.8073690).
12. Doshi, J., Patel, T., & Bharti, S. kumar. (2019). *Smart Farming using IoT, a solution for optimally monitoring farming conditions*. *Procedia Computer Science*, 160, 746–751. <https://doi.org/10.1016/j.procs.2019.11.016>
13. Farooq, M. S., Riaz, S., Abid, A., Umer, T., & Zikria, Y. B. (2020). *Role of IoT Technology in Agriculture: A Systematic Literature Review*. *Electronics*, 9(2), 319. <https://doi.org/10.3390/electronics9020319>
14. G. Sushanth and S. Sujatha, "IOT Based Smart Agriculture System," 2018 *International Conference on Wireless Communications, Signal Processing and Networking (WiSP-NET)*, Chennai, 2018, pp. 1-4, doi: [10.1109/WiSPNET.2018.8538702](https://doi.org/10.1109/WiSPNET.2018.8538702).
15. S. R. Prathibha, A. Hongal and M. P. Jyothi, "IOT Based Monitoring System in Smart Agriculture," 2017 *International Conference on Recent Advances in Electronics and Communication Technology*

- (ICRAECT), Bangalore, 2017, pp. 81-84, doi: 10.1109/ICRAECT.2017.52.
16. R. N. Rao and B. Sridhar, "IoT based smart crop-field monitoring and automation irrigation system," 2018 2nd International Conference on Inventive Systems and Control (ICISC), Coimbatore, 2018, pp. 478-483, doi: 10.1109/ICISC.2018.8399118.
  17. R. Dagar, S. Som and S. K. Khatri, "Smart Farming – IoT in Agriculture," 2018 International Conference on Inventive Research in Computing Applications (ICIRCA), Coimbatore, 2018, pp. 1052-1056, doi: 10.1109/ICIRCA.2018.8597264.
  18. Article: <https://www.biz4intellia.com/blog/5-applications-of-iot-in-agriculture/>
  19. IoT and understanding article: <https://www.iotforall.com/what-is-iot-simple-explanation/>
  20. IoT equipments understanding: <https://www.arm.com/glossary/iot-devices>