

CHI KIN (BENNETT) YIM, DAVID K. TSE, and KIMMY WA CHAN\*

This study extends the existing satisfaction–trust–loyalty paradigm to investigate how customers’ affectionate ties with firms (customer–firm affection)—in particular, the components of intimacy and passion—affect customer loyalty in services. In a bilevel model, the authors consider customer–staff and customer–firm interactions in parallel. Through a netnography study and survey research in two service contexts, they confirm (1) the salience of intimacy and passion as two underrecognized components of customer–firm affection that influence customer loyalty, (2) the complementary and mediating role of customer–firm affection in strengthening customer loyalty, (3) significant affect transfers from the customer–staff to the customer–firm level, and (4) the dilemma that emerges when customer–staff relationships are too close. The findings provide several implications for researchers and managers regarding how intimacy and passion can enrich customer service interactions and how to manage customer–staff relationships properly.

*Keywords:* customer–firm affection, intimacy, passion, customer loyalty, affect transfers

## Strengthening Customer Loyalty Through Intimacy and Passion: Roles of Customer–Firm Affection and Customer–Staff Relationships in Services

Adopting a relational paradigm for services marketing offers obvious promises. For managers, strong and stable customer relationships deliver favorable word of mouth (Verhoef, Franses, and Hoekstra 2002), justify price premiums (Bolton 1998), reduce employee training costs, and even lower staff turnover (Sheth and Parvatiyar 1995), all of which leads to higher firm profits. This paradigm also rejuvenates scholarly research into satisfaction and customer loyalty (Bolton 1998). First, it promotes constructs such as firm trust and commitment, which helps distinguish relational from transactional services (Berry 1995). Second, it stimulates cross-level studies that bridge customer- and

firm-level domains, enabling us to examine how firms develop, sustain, and benefit from strong customer relations (Sirdeshmukh, Singh, and Sabol 2002).

Yet research and managerial promises have not materialized fully, and questions remain regarding the power of the well-accepted linkage of satisfaction to trust to loyalty, on which many customer relationship programs have been anchored. Fournier, Dobscha, and Mick (1998) challenge the effectiveness of customer relationship programs because loyalty in services remains elusive and unpredictable (Agustin and Singh 2005). As the following quotation illustrates, building customer loyalty remains a key priority but also a problem area for many service managers:

The old [customer relationship management] agenda as a bandage should now be replaced with the new agenda of *customer intimacy*, that is, to make customers feel good whenever they make contact with your company. Every interaction isn’t a moment to be avoided or cut short, but an opportunity for further intimacy with the customer.... Your employees are closest to the action; they know what works and what doesn’t work for the

---

\*Chi Kin (Bennett) Yim is Professor of Marketing (e-mail: yim@business.hku.hk), and David K. Tse is Chair Professor of International Marketing (e-mail: davidtse@business.hku.hk), School of Business, University of Hong Kong. Kimmy Wa Chan is Assistant Professor of Marketing, Department of Management and Marketing, Hong Kong Polytechnic University (e-mail: mskimmy@polyu.edu.hk). This research was funded by a Hong Kong SAR RGC research grant awarded to the first two authors. Ruth Bolton and Jeffrey Inman served as associate editors for this article.

customers. (Steve Ballou, IBM Institute for Business Value; see IBM Global Services 2006, emphasis added)

Perhaps firms fail to build strong customer loyalty because they are unable to create strong emotional bonds with their customers (Fournier, Dobscha, and Mick 1998; McEwen 2005).

At the same time, many firms underestimate the contribution of customer–staff interactions to customer loyalty. Although they recognize the salience of customer–staff relationships for favorable service experiences, many discourage staff from developing strong relationships with customers for fear that such relationships might divert customer loyalty to the staff rather than the firm (Bendapudi and Leone 2002; Palmatier, Scheer, and Steenkamp 2007).

This study responds to both these tenets. First, we apply the triangular theory of love (Sternberg 1986), which postulates that intimacy, passion, and commitment are three constituent components of love, to conceptualize customers' strong, enduring affectionate bonds with a firm (hereinafter, customer–firm affection).<sup>1</sup> Unlike existing literature that regards commitment as the sole pillar, our study proposes complementary contributions of intimacy and passion to customer loyalty formation. Second, we delineate how customer–staff relationships may contribute to customer loyalty. Favorable customer–staff interactions prompt positive customer–staff relationships, which helps strengthen customer–firm linkages. Accordingly, a dual strategy to enhance favorable relationships at both customer–staff and customer–firm levels appears to be warranted (Reynolds and Beatty 1999). However, if customer–staff relationships dominate, a potential “hostage” situation emerges, in which service staff can “kidnap” customers (Bendapudi and Leone 2002). Yet the salience of the affect transfer underlying this double-edged sword dilemma (i.e., to promote or not to promote favorable customer–staff relationships) has not been assessed in service loyalty studies.

Service contexts are known for their diversity in the degrees of customer–staff interactions. By testing our propositions in two service contexts—one transactional (fast-food restaurant) and one relational (hair salon)—we aim to enhance our model's validity. Thus, we assess how the salience of (1) customer–firm affection, (2) affect transfer from the customer–staff to the customer–firm level, and (3) the double-edged sword effect operates differentially in different service contexts. We posit that the strength of some customer–firm affection components, such as passion, is greater for transactional than for relational services. We also believe that the amount of affect transfer is greater for relational than for transactional services. In short, we postulate that the service typology moderates the relative salience of customer–firm affection components and affect transfer. We use a netnography study and a survey of real-

world consumers to improve the applicability of our findings.

### CONCEPTUAL BACKGROUND

#### *Concept of Love, Sternberg's Triangular Theory of Love, and Attachment Theory*

Love is a global concept that artists, philosophers, and social scientists commonly define as a subjective, holistic integration of thoughts, feelings, and prior actions (Fehr 1988). As a powerful motivator, love can twist a person's perceptions, define affective boundaries, and cause a person to defy costs and risks. Thus, love is vital in forming enduring relations (Kelley 1983).

Psychologists conceptualize love in great detail. Early work by Hatfield and Walster (1978) classifies love into companionate and passionate types. Shaver and colleagues (1987) refine it to include affection, lust, and longing. Sternberg (1986, 1988) synthesizes previous attempts and defines love according to three constituent components: intimacy, passion, and commitment. Intimacy refers to the bondedness and connectedness of a relationship; it culminates in a relationship in which people “experience warmth.” Passion pertains to the romantic essence of a relationship and reflects intense feelings of attraction and desire (Sternberg 1986). Whereas passion can spike up or down within a short time, intimacy is a matter of “knowledge” that accumulates (Ahuvia 2005; Sternberg 1988). Brehm (1988) notes that physical separation may reduce intimacy but fuel passion and strengthen desire. Thus, intimacy and passion are powerful components that represent love's emotional and motivational drivers. In contrast, commitment refers to a cognitive aspect of love (Shimp and Madden 1988); it transforms the interaction from an instantaneous, transactional exchange to a strong and enduring relationship.

Using various combinations of these three components, Sternberg (1988) delineates eight different types of love and depicts them with a variety of triangles that reveal both the amount (area of the triangle) and the balance (shape) of love. The larger the triangle, the more love is represented. An equilateral triangle reflects consummate love in which all three components are equally strong, a scalene triangle in which passion dominates represents infatuation, and an isosceles triangle in which intimacy plays the greatest part reflects simple liking. Thus, Sternberg's theory provides instrumental insights into typologizing and measuring love.

Attachment theory (Ainsworth 1973; Bowlby 1969) provides another theoretical foundation for the dynamics and functions of love in relationships with friends (Trinke and Bartholomew 1997), romantic partners (Hazan and Shaver 1987), prized possessions (Ball and Tasaki 1992), and brands (Park, MacInnis, and Priester 2006; Thomson, MacInnis, and Park 2005). Attachment theory was first developed to explain infant–caregiver relationships by conceptualizing attachment as an infant's inborn, goal-corrected control system that regulates his or her behaviors to obtain (or maintain) proximity to a specific giver or attachment figure and thus secure protection from physical and psychological threats and promote emotion regulation and healthy exploration (Bowlby 1969). Similarly, people develop attachments to objects (e.g., products, stores, brands) that they can count on to fulfill their functional,

<sup>1</sup>We thank the editor for suggesting the use of the term “customer–firm affection.” Some recent studies (e.g., Carroll and Ahuvia 2006) use the term “love” to label consumers' “lovelike” affection for particular brands, products, or consumption activities. The intensity of these lovelike affections ranges from simple liking to an intense emotional attachment with these objects of affection. However, in general, love refers to romantic, interpersonal relationships. To distinguish such differences, we use the term “customer–firm affection” to refer to the affectionate bonds customers form with services, such as fast-food restaurant and hair salons.

experiential, and emotional needs (Park, MacInnis, and Priester 2006).

Sternberg's love theory and attachment theory differ, but they share key commonalities. For example, Sternberg considers commitment a component of love, whereas Park, MacInnis, and Priester (2006) argue that it is an outcome of brand attachment. Nevertheless, both conceptualizations emphasize emotional connectedness (or intimacy) between the person and the attached object (Sternberg 1987). As Sternberg does, McEwen (2005) and Thomson, MacInnis, and Park (2005) postulate that passion plays a central role in forming brand attachment. McEwen even argues that passion is the apex of the pyramid of brand attachment. In summary, both attachment theory and Sternberg's love theory define people's affectionate bonds with other people, objects, or brands as a multifaceted construct in which intimacy (connectedness) and passion are its core elements.

#### *Love of Products, Love of Brands, and Love of Service Firms*

Consumers are known to develop strong affectionate ties with products and activities (Carroll and Ahuvia 2006; Chaudhuri and Holbrook 2001; Fournier 1998). In a series of six studies, Fehr and Russell (1991) show that people display different types of noninterpersonal love toward art, food, sports, money, and so forth. These affectionate ties also apply to brands, ranging in intensity from friendly affection to passionate love and even addictive obsession. Carroll and Ahuvia (2006) and Thomson, MacInnis, and Park (2005) separately develop scales to identify brand love and confirm that it is distinct from brand attitude, satisfaction, or involvement in both high-involvement (e.g., car) and low-involvement (e.g., consumer packaged goods) contexts. These studies also establish that affectionate ties with brands link to consumers' commitment (Fournier 1998) and loyalty (Thomson, MacInnis, and Park 2005) to the brand.

Consumption objects that consumers love may include service firms (Chaudhuri and Holbrook 2001; McEwen 2005; Shimp and Madden 1988); for example, Chaudhuri and Holbrook (2001) suggest that a customer's loyalty to a restaurant results from strong emotional feelings toward it. However, customers' affectionate ties with service firms rarely receive research attention. Anecdotal evidence in practitioner publications argues that customers feel love toward service firms when they experience successful interactions with the servicescape (e.g., a piano at Nordstrom) and service staff (e.g., flight attendants of Singapore Airlines, baristas at Starbucks) over time (McEwen 2005; Spector and McCarthy 2005). Cultivating "customer love" through exceptional service may be the "Big Kahuna" of customer loyalty (Bell 2000). From these findings, we draw three main implications. First, customers form strong affectionate ties with service firms. Second, exceptional service drives customer-firm affection. Third, customer-firm affection is a potentially viable construct that may provide the missing link to loyalty in services.

#### *Passion, Intimacy, and Commitment in Service Exchanges*

On the basis of case studies of a large U.S. retail bank and a Japanese luxury retailer, Fleming, Coffman, and Harter (2005) report that customers who are passionate about firms have substantially lower attrition rates and higher spending levels than those who are not. Customers

who score in the upper 15%–20% on their emotional attachment measure deliver a 23% premium, compared with the average customer, in share of wallet, revenue, profitability, and relationship growth. Edwards and Day (2005) cite several British firms (e.g., Camper, Co-Operative Food, Co-Operative Bank) as examples of people's passion toward service firms.

Support for the concept of intimacy in customer-firm affection also emerges from social exchange theories, which postulate that people are motivated to engage in relationships (Emerson 1987). As relationships develop, interactions increase, and participants grow increasingly intimate, followed by stronger attachments and positive emotional ties (Saavedra and Van Dyne 1999). In the service context, intimacy between firms and customers might form in similar ways through positive consumption interactions.

Marketing literature includes a rich tradition of applying interpersonal relationship theories to the study of customer-firm interactions. Such works provide insights into the role of commitment in customer-firm relationships, indicating that it mediates satisfaction and future intentions (Bansal, Irving, and Taylor 2004; Garbarino and Johnson 1999). Other research confirms the effect of commitment on customer retention and customer share development over time (Verhoef 2003). Yet this stream of research largely ignores how intimacy and passion may contribute to relationship formation (Fournier 1998).

Sternberg's triangular theory of love can serve as the theoretical foundation for customer-firm affection in service exchanges for several reasons. First, marketing researchers often use interpersonal love as an appropriate framework for studying "lovelike" attachments in customer-object relationships (e.g., Shimp and Madden 1988), buyer-seller relational exchanges (e.g., Dwyer, Schurr, and Oh 1987), and brand love/attachment (e.g., Carroll and Ahuvia 2006; Thomson, MacInnis, and Park 2005). Second, of the various love theories, Sternberg's (1986, 1988) has received the most attention and support in general and in the marketing literature in particular (Fournier 1998; Shimp and Madden 1988). Third, recent research into customer-object love (e.g., Ahuvia 2005; Park, MacInnis, and Priester 2006; Thomson, MacInnis, and Park 2005) suggests that people love consumption objects, which enable them to express themselves and construct a sense of self in the face of identity conflicts; these self-defining and expressive functions of loved objects also emerge for service firms (Sirgy, Grewal, and Mangleburg 2000). Fourth, customer-firm affection develops as a result of customers' successful interactions with not only non-human aspects of the services, such as the servicescape, but also service personnel. Therefore, the relationship between customers and service firms inherently becomes somewhat interpersonal (Iacobucci and Ostrom 1996), so an interpersonal love framework is applicable to examine affectionate bonds between customers and service firms (versus objects).

#### *Customer-Firm Affection as a Distinctive Construct*

Customer-firm affection differs from two related constructs—satisfaction (Oliver 1980) and consumption affect (Westbrook and Oliver 1991)—in terms of its formation, nature, and effect. First, customer-firm affection reflects an

affectionate, enduring bond, often formed through multiple favorable experiences and interactions. In contrast, satisfaction and consumption affect (Westbrook and Oliver 1991) are specific to an experience (e.g., How satisfied [happy] are you with our hotel service?). That is, whereas satisfaction and consumption affect measure the “flow” of experience, customer–firm affection summarizes these flows into a holistic affectionate bond. Second, customers develop lovelike attachments to a service firm when the firm allows them to define or express themselves; consumption affect requires no such condition. Third, although all three constructs are multidimensional, customer–firm affection consists of three components, whose different combinations result in distinctively different types of love (Sternberg 1988), unlike either satisfaction or consumption affect. Fourth, customer–firm affection represents positive feelings; its lower bound is defined as the absence of any particular feelings for a service firm (Shimp and Madden 1988). In contrast, consumption affect includes both positive and negative (e.g., distress) feelings (Westbrook and Oliver 1991). Fifth, although satisfaction (and, to a lesser extent, consumption affect) drives consumer postconsumption behaviors, such as complaint, repurchase, and brand loyalty, we postulate that customer–firm affection provides a complementary effect through an affection-based and relationship-prone route.

#### *The Netnography Study*

We use data from the Lovemarks Online Community for our netnography study (The Future Beyond Brands; see <http://www.lovemarks.com/>) because of the Web site’s relevance to our research focus (ten categories of 2858 brands/firms),<sup>2</sup> its inclusion of low- and high-involvement contexts, its high activity level (more than 10,000 consumers, 15 million page views, and 9000 plus links and comments), and its global reach (U.S., European, and Asian consumers). Thus, it provides an externally valid platform for researchers to study consumer love of brands and firms.

Of the posted comments, we exclude categories that are unrelated to objects and firms (e.g., people, sports, media, places). Because our purpose is to uncover the constituent components of affection toward a firm, we screen the selected postings and exclude those that express negative feelings and multiple postings by the same person. We select postings that are relevant to customer–firm affection developed as a result of successful interactions with staff, products/services, or the servicescape of stores or service firms. These criteria reduce the number of qualified postings to 691, most of which were posted between November 2002 and October 2006. We then create our final sample for

<sup>2</sup>The ten major categories are (1) food and beverage (e.g., Nescafé, McDonald’s, Burger King, Coca-Cola) with 536 brands; (2) people (e.g., pop singers and stars, including Madonna and Jackie Chan) with 236 brands; (3) auto, marine, and aviation (e.g., BMW, Southwest Airlines) with 126 brands; (4) fashion and beauty (e.g., Abercrombie & Fitch, April Cornell) with 456 brands; (5) entertainment (e.g., *Fear Factor*, *Band of Brothers*, iTunes) with 290 brands; (6) places (e.g., Germany, Harvard Business School, Hilton) with 210 brands; (7) sports (e.g., FIFA World Cup, As Roma, Boston Red Sox) with 164 brands; (8) technology (e.g., Sony, Nokia, Orange) with 170 brands; (9) media (e.g., BBC, *BusinessWeek*, alien series) with 298 brands; and (10) others (e.g., IKEA, 3M, Lego) with 372 brands. The Web site has been updated since we completed our data collection; the “others” category now consists of home and living, retail and shopping, and others categories.

the classification analysis by selecting every third posting within each category (in alphabetical order of firm/store names). Therefore, the sample contains 230 postings.

We adopt a three-step procedure for “expert judging” (Krippendorff 2004) to content analyze the selected comments. First, two of the authors developed, pretested, and finalized the judging instructions and coding schemes. Second, we recruited two graduate students and trained them in the definitions of the three components of customer–firm affection. The judges coded two training samples (20 postings each) until their interrater reliability reached the .80 cutoff point (Krippendorff 2004). Third, the two judges independently coded the remaining 190 postings and reached a high level of interrater reliability (>.90). We rejected 7 postings because the judges could not reach an agreement. Examples of postings displaying components of customer–firm affection appear in Table 1 (for more information on the netnography study, see the Web Appendix at <http://www.marketingpower.com/jmrdec08>).

The results support the applicability of Sternberg’s love paradigm to conceptualize customer–firm affection, in that consumers’ expressions of affection toward firms include terminology consistent with intimacy, passion, and commitment. The three components apply to both low-involvement (convenience stores, fast-food restaurants) and high-involvement (education, financial services) categories. Postings about high-involvement categories tend to reveal relatively high commitment, whereas those about low-involvement categories are relatively higher in passion, though both achieve similar ratings on intimacy.<sup>3</sup> We discuss these qualitative results further in the hypotheses section.

#### *Customer–Staff Relationships*

By assuming a broader relational perspective, current studies expand research on customer–firm transactions to include interpersonal relationships between customers and service employees. This development, which separates customer evaluations of the service firm from those of service employees, proves salient for both business-to-business (B2B) and business-to-consumer (B2C) services (Iacobucci and Ostrom 1996).

In a B2B context, Bolton, Smith, and Wagner (2003) suggest that business customers make conscious distinctions between aspects of service attributable to the service agent and those attributable to the organization. Using a resource exchange theory–driven model, they show that B2B customers optimize relationships by trading off social resources (related to staff) with economic resources (related to service firm). Their finding suggests that managers should strike a proper balance between deploying service employees and structuring service operations in their service delivery systems. Furthermore, their suggestion to manage these bilevel relationships separately is supported by Doney and Cannon (1997).

In B2C services, managing bilevel relationships among customers, employees, and firms appears equally promi-

<sup>3</sup>Intimacy = 31.1%<sub>low</sub> versus 31.3%<sub>high</sub>, passion = 13.4%<sub>low</sub> versus 6.3%<sub>high</sub>, commitment = 23.5%<sub>low</sub> versus 34.4%<sub>high</sub>, intimacy and passion = 4.2%<sub>low</sub> versus 3.1%<sub>high</sub>, passion and commitment = 15.1%<sub>low</sub> versus 6.3%<sub>high</sub>, intimacy and commitment = 10.9%<sub>low</sub> versus 18.8%<sub>high</sub>, and intimacy and passion and commitment = 1.7%<sub>low</sub> versus 0%<sub>high</sub>.

Table 1  
SAMPLE POSTINGS DISPLAYING CUSTOMER-FIRM AFFECTION

*Intimacy:* "I love to go to Starbucks even though I'm not really a coffee-lover as I think it's not healthy. Every time I go there, it gives me a homely feeling, which is very warm and close; it welcomes me to stay as long as I want and is a place for me to take a good break." (Hong Kong, 2002)

*Passion:* "I miss IKEA, and so do many of my friends in New Zealand. I have contacted the company that owns IKEA franchise in NZ, and they have told me they have no plans of opening IKEA in NZ. Pity.... Toronto, Canada especially has 1 IKEA for every 700K people. In Auckland alone it's over a million and yet no IKEA. Come on—open up! We need it here. Check the market prices for furniture—it's a goldmine!" (New Zealand, 2006)

*Commitment:* "Standing the test. My parents live in the bay area of San Francisco, and I go to college in L.A., so I'm often traveling between California's two main urban centers. I'd flown Southwest before but never regularly. That's the true test of any airline; can it stand the test of repeated flights? Will the little annoyances become unbearable? Well, Southwest is the cheapest, most efficient, easiest 'short hop' airline I've ever flown. Their flights are on time or early almost without fail, and the self check-in is amazing. Whenever I can, I fly Southwest." (United States, 2003)

*Intimacy and passion:* "Love love love the chicken! I'm from a small town in South Carolina, and we pretty much live on sweet tea, biscuits, and chicken. Whenever my friends visit from up north, I always take them to Chick-Fil-A and they are speechless. I think it is the greatest place to eat ever! I go at least four times a week. It's a small piece of heaven if you ask me." (United States, 2005)

*Passion and commitment:* "Zara is the place I go when I need fashionable clothes. It's the first, and most of the time the only, store I need to go whenever looking for nice clothes. I can't live without it anymore, I'm addicted to it! It's the only place I go and never leave without spending some money!" (Brazil, 2006)

*Intimacy and commitment:* "I have been a customer of Ambience Salon and Spa (by The Hairy Cactus) for five years or more. I enjoy the friendly staff that greet me at the door as well as the extra sensory experience cards they provide. It is always a treat to choose 'an extra' service to accompany the treatment provided. I love the 'ambience' of the new salon. The atmosphere (especially the colors and decor) is exactly the type of environment I want to view when getting my treatments." (United States, 2004)

*Intimacy, passion, and commitment:* "Whenever my life feels out of control I head to The Container Store. Sometimes I just wander the isles. Sometimes I buy supplies to overhaul a closet. Regardless, every time I enter the store a sense of calm comes over me. The employees are always happy and helpful. Never, ever pushy. The store is always immaculate. No matter how many times I visit, I always find something new. I decide to follow my passion. So I am a prime time employee at The Container Store. I can tell you the only thing that beats being a Container Store customer is being a Container Store employee. The Container Store is truly a Love-mark to its customers and employees." (United States, 2005)

ment. In retail sales, Beatty and colleagues (1996) confirm the need to distinguish between relationship selling (i.e., locking customer and sales associate together) and relationship marketing (i.e., connecting customer to firm) because the former accrues benefits to the staff, perhaps at the expense of the firm. Czepiel and Gilmore (1987) note that some customers form dual bonds, which prompts them to develop different expectations and evaluations of their service experience (Reynolds and Beatty 1999). Swan and Oliver (1989) confirm that the antecedents and consequences of salesperson and store satisfaction may differ because consumers might be satisfied with their overall

experience or just with their interactions with salespeople. Sirdeshmukh, Singh, and Sabol (2002) take this perspective further and propose that consumers form dual trust and loyalty toward frontline employees and firm policies and practices. In summary, extant research suggests that models that contain distinctive, separate consumer evaluation processes of service employees and firms must be built.

PROPOSED MODEL AND HYPOTHESIS DEVELOPMENT

We depict our proposed framework in Figure 1, which builds on established service quality and customer satisfac-

Figure 1  
FRAMEWORK DEPICTING THE BILEVEL PROCESS OF RELATIONAL EXCHANGES

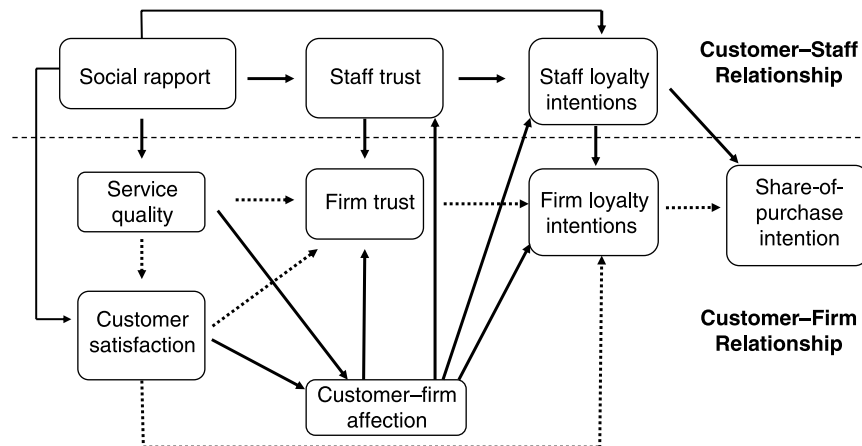

Notes: Solid arrows denote the focal relationships in this study; dotted arrows denote relationships already established by prior research.

tion paradigms with three extensions. First, we postulate that customers develop affectionate bonds with firms through their repeated experience of high levels of service quality and satisfaction. Second, we propose that customer–staff relationships exert direct and indirect (through customer–firm relationships) influences on consumer loyalty. Third, we examine the roles of customer–firm affection and interpersonal relationships for loyalty development in transactional and relational services.

*Extant Model 1: Links Among Quality, Satisfaction, Trust, and Loyalty at the Firm Level*

Service quality and customer satisfaction represent two major paradigms that describe how consumers develop loyalty toward firms. The former examines service evaluations through quality dimensions and links them to future purchases (Parasuraman, Zeithaml, and Berry 1988); the latter emphasizes satisfaction as a direct and positive driver of loyalty (Oliver 1980; Reynolds and Beatty 1999). Marketing scholars (Bitner and Hubbert 1994) regard quality and satisfaction as unique constructs that offer distinct contributions to the understanding of service evaluation and consumer loyalty formation.

Studies also assess how trust mediates satisfaction and loyalty (Hennig-Thurau and Klee 1997). Trust captures the commitment element of a satisfying consumption experience and functions as an aggregate evaluation that motivates a consumer to form an enduring tie with the firm (Selnes 1998). Similar findings in the B2B context indicate that interfirm trust determines stable B2B relationships (Yilmaz, Sezen, and Ozdemir 2005). In summary, our core model postulates that quality links positively to satisfaction, which in turn links positively to loyalty and is mediated by firm trust.

*Extant Model 2: Links Among Social Rapport, Trust, and Loyalty at the Staff Level*

Various studies contribute by conceptualizing the components of customer–staff relationships and their salience for repurchase intentions and referrals across service contexts. Trust toward service staff (Doney and Cannon 1997; Macintosh and Lockshin 1997; Sirdeshmukh, Singh, and Sabol 2002), satisfaction (Bolton, Smith, and Wagner 2003; Reynolds and Beatty 1999), rapport (Gremler and Gwinner 2000), and commitment/loyalty (Macintosh and Lockshin 1997; Reynolds and Beatty 1999) represent salient relational factors for customer–staff relationships.

We examine three components: social rapport, staff trust, and staff loyalty. Social rapport refers to a customer's perception of an enjoyable interaction with a staff member, characterized by his or her personal connection (Gremler and Gwinner 2000). Appropriate rapport enhances social bonding, reduces uncertainties about the relational outcome, and indicates that the staff is committed to the customer's best interest (Crosby, Evans, and Cowles 1990); in turn, it motivates customers to form trusting relationships with staff members. Finally, staff trust helps lower the risks of service exchanges and actively builds ongoing connections. Price and Arnould (1999) suggest that customers become loyal because they connect, or develop rapport, with service staff. Lewicki and Bunker (1995) also argue that the stronger the bond, the more difficult it becomes for

customers to end the relationship. In summary, social rapport is positively related to staff trust and staff loyalty.

*Model Extension 1: Cross-Level Transfer (Customer–Staff to Customer–Firm)*

As we noted previously, extant literature highlights the need to analyze customer, staff, and firm relationships in a bilevel manner to unfold the dual processes in a service exchange that require staff involvement (Macintosh and Lockshin 1997). This dual-process notion helps us analyze how customer–staff trust and loyalty might transfer to customer–firm trust and loyalty. Gummesson (1987) confirms that positive customer–frontline staff relationships, which incorporate a social dimension, contribute to customer perceptions of service firm quality. Customers who have strong relationships with service staff commit to the firm, which strengthens the customer–firm relationship (Butcher, Sparks, and O'Callaghan 2002). In B2B services, Bolton, Smith, and Wagner (2003) find that firms can provide more social resources to compensate for lower levels of economic resources; an increase in social investments appears to reduce the negative effect of lower structural aspects of a service.

This cross-level transfer of trust and loyalty receives support from both affect transfer mechanisms and attribution theory. No matter the strength of customer–staff relationships, consumers must remember the firm name to locate their preferred staff, so the firm name enhances consumers' ability to connect to the service staff. In turn, service staff need the firm's support system to deliver the service, so trust in service excellence should migrate to trust in the operating system and, finally, to the firm. If consumers value their relationship with the staff, their intention to continue relying on the staff and the firm should increase (Macintosh and Lockshin 1997). Moreover, according to attribution theory, consumers attribute the staff's behavior to firm management (Bitner, Booms, and Tetrault 1990), so better service prompts consumers to give credit to the firm, which facilitates affect transfer across the customer–staff and customer–firm levels. Similar transfers should occur with relational factors such as trust and loyalty.

H<sub>1a</sub>: Staff trust has a positive effect on firm trust.

H<sub>1b</sub>: Staff loyalty intentions have a positive effect on firm loyalty intentions.

*Model Extension 2: Mediating Role of Customer–Firm Affection*

Our model proposes that customer–firm affection powerfully mediates the relationships among service quality, customer satisfaction, firm trust, and firm loyalty. Consistent with Buss's (1988) evolutionary approach, we argue that firms can display and offer excellent service quality and satisfaction (as rewards) to attract consumers and cause them to develop affectionate ties. This claim agrees with the reinforcement-affect model, which postulates that rewards offered in social interactions motivate attraction and social relationships (Emerson 1987). In short, excellent service quality and satisfaction provide the necessary ingredients for customer–firm affection, as supported by the following comments from the netnography study:

There are two outstanding things about Starbucks: they provide an absolutely consistent product, and they

always SMILE! And for that, I will seek them out every time. (United States, 2006)

Take me to the Hilton! When you stay at the Hilton, wherever in the world, there is always this high standard for quality. Staying here is all about prestige, luxury, customer care and making you feel special. (Canada, 2005)

As a strong, intense emotion that involves overt actions, love awakens and shapes people's beliefs and makes them resistant to change (Frijda, Manstead, and Bem 2000). In social relationships, trust reflects a core belief influenced by the strong affectionate nature of love (Branden 1988). Therefore, customer-firm affection should exert significant impacts on consumers' trust and loyalty toward the firm.

Customer-firm affection also involves strong behavioral outcomes through a two-step relationship continuation process. First, the affective experience motivates customers to approach the firm more frequently. Second, as interdependence and commitment grow, customers ignore other alternatives, willingly sacrifice for the relationship, and display prorelationship behaviors (Gonzaga et al. 2001). Service literature suggests that such bonds oblige consumers to be more loyal to the same firm (Bansal, Irving, and Taylor 2004); the more affectively attached consumers feel, the more likely they are to continue patronizing the service provider (Fleming, Coffman, and Harter 2005). Support also emerges from the comments extracted from our netnography study:

Thank you for being here through hard times in my life. You (QuikTrip) always seem to understand and take care of me. I can always count on you to give me what I need, I think I love you. (United States, 2006)

Zara is the place I go when I need fashionable clothes. It's the first and, most of the time, the only store I need to go whenever looking for nice clothes. I can't live without it anymore, I'm addicted to it! It's the only place I go and never leave without spending some money!" (Brazil, 2006)

On the basis of this discussion, we hypothesize the following:

H<sub>2</sub>: Customer-firm affection mediates the effects of service quality and customer satisfaction on firm trust and firm loyalty intentions.

### *Model Extension 3: Relationship Formation in Transactional and Relational Services*

Most services can be classified along a relational-transactional continuum (Dwyer, Schurr, and Oh 1987; Macneil 1980). By cluster-analyzing core characteristics of services, Bowen (1990) uncovers three distinct groups: (1) services directed at people through high customer contact and high customization; (2) services directed at a person's property, which require moderate to low customer contact and low customization; and (3) services directed at the mass public that offer standardized service, moderate customer contact, and low customization. Bowen cites hair salons and fast-food restaurants as exemplars of the first and third groups, respectively.

*Differences in the geometry of affection.* For hair salons, a relational service, the amount of affection should be

greater than that displayed for fast food, a transactional service, because the former requires more interactions conducive to developing affectionate bonds. We also expect the balance of customer-firm affection in relational services to lean toward commitment, whereas in transactional services, it should be more passion oriented. Relational services demand longer duration, help customers gain a better understanding of the aims and operations of the firm, and prompt stronger commitment (Hut and Speh 1995). In contrast, customers experience lower involvement and seek more variety to fulfill their excitement-seeking motivations in transactional services. We ask respondents to rate their experiences with their most often visited fast-food restaurant and hair salon, so the intimacy levels across both services should be reasonably similar.

H<sub>3a</sub>: Customers develop more customer-firm affection in relational services than in transactional services.

H<sub>3b</sub>: Customer-firm affection in a relational setting is commitment oriented (commitment rating is higher than passion rating), whereas in a transactional setting, it is passion oriented (passion rating is higher than commitment rating).

*Differences in affect transfer and the double-edged sword.* Affect transfer from the customer-staff to the customer-firm level should be stronger in relational than in transactional services for two reasons. First, service staff in relational services function as prominent firm agents, and their performance represents a key characteristic of the service. Second, relational services focus on the exchange process and thus require higher levels of interdependence (Dwyer, Schurr, and Oh 1987; Macneil 1980). In contrast, staff plays a relatively minor role and provides less salient indicators of service quality in transactional services, which tend to focus on exchange outcomes and involve lower interdependence levels (Macneil 1980). Therefore, customer-staff loyalty should exert a stronger impact on customer-firm loyalty in relational than in transactional services.

Strong customer-staff loyalty may lead to a hostage effect, in which service staff use their relationship to kidnap customers and thereby create a double-edged sword dilemma (e.g., Beatty et al. 1996). If the employee leaves the firm, the customer may leave with him or her (Bendapudi and Leone 2002), and firms have limited responses. Suppressing customer-staff relationships is unnatural and destructive, but allowing them to dominate customer-firm loyalty could harm firm performance. Therefore, we assess affect transfers from the customer-staff to the customer-firm level in transactional versus relational service contexts.

H<sub>3c</sub>: The positive effect of staff trust on firm trust is stronger for relational services than for transactional services.

H<sub>3d</sub>: The positive effect of staff loyalty intentions on firm loyalty intentions is stronger for relational services than for transactional services.

### *RESEARCH DESIGN AND METHOD*

We chose to study fast-food and hair salon services. Fast food is often standardized with limited customer contact (Bowen 1990) and attracts customers with price, speed of service, consistency, and convenient location (Kasdan 1996). Hairstyling involves interactions and customization, compels intimacy (McCracken 1995), and requires cooper-

ative actions and adjustments by both parties, who then share the benefits and burdens of the exchange and are motivated to engage further. Hairdressers frequently are informal sources of social support and assistance to customers with personal problems, and customers often look to them for psychological counsel and to unburden their “souls”; in turn, hairdressers acknowledge and absolve, listen and forgive, and thus cut hair while also cutting away guilt (McCracken 1995). Customer–hairdresser relationships may entail intimate bonds of mutual respect, trust, affection, and deep connections with vast emotional consequences. Thus, fast food and hairstyling are appropriate examples of the transactional–relational service continuum that fit our research purpose.

We designed the survey, its objectives, and measures and then commissioned a professional market research firm to execute the survey. We monitored the firm’s data collection process to ensure the quality of the collected data. The firm drew 980 potential respondents from three major metropolitan areas in Hong Kong from a residential telephone directory. Professionally trained interviewers contacted the respondents, providing the name of the university and the nature of the project, to solicit respondent cooperation. We offered a cash incentive equivalent to US\$30 to each respondent who completed surveys on both services. Respondents were at least 18 years of age and had visited a fast-food restaurant and hair salon at least once in the prior six and nine months, respectively. Respondents identified the restaurant and salon they visited most often to serve as the focal service firms. Of the 450 respondents (45.92%) who completed the interviews, after observations with missing data were excluded, 360 respondents (44% male

and 56% female) remained.<sup>4</sup> We assessed nonresponse bias by comparing qualified and nonqualified respondents and found no significant demographic differences between the two groups.

The survey includes questions about the target restaurant and salon (in randomized order), as well as measures of service quality, satisfaction, social rapport, customer–firm affection, customer trust, and loyalty toward the staff and firm. All measures were professionally translated through back translation (Chinese and English) to ensure conceptual equivalence. We pretested and modified the questionnaire items with a sample of 35 consumers. We adapted the measures from previous research, with minor wording modifications to fit our study context. Unless otherwise noted, all items use a five-point Likert scale (1 = “strongly disagree,” and 5 = “strongly agree”). In the Appendix, we list the scale items, and in Table 2, we report their descriptive statistics.

For service quality, we adapted Parasuraman, Zeithaml, and Berry’s (1988) five-dimensional SERVQUAL measure and used the aggregate measures of each dimension to form an overall service quality measure (Henning-Thurau and Klee 1997). We used a cumulative approach to measure

<sup>4</sup>We conduct t-tests to examine potential gender differences for all constructs in both service contexts. The results indicate no significant differences between male and female subsamples, except for customer–firm affection in the fast-food restaurant context ( $\bar{x}_{\text{female}}(3.30) > \bar{x}_{\text{male}}(3.16)$ ,  $p < .10$ ) and staff loyalty in the hair salon context ( $\bar{x}_{\text{female}}(3.62) > \bar{x}_{\text{male}}(3.39)$ ,  $p < .05$ ). These results are reasonable; women tend to exhibit more and stronger interpersonal relationships and higher involvement (Fourmier 1998).

Table 2  
DESCRIPTIVE STATISTICS OF THE CONSTRUCTS IN FAST-FOOD RESTAURANT AND HAIR SALON

Construct (Fast-Food Restaurant)	1	2	3	4	5	6	7	8	9
1. Service quality	1.000								
2. Customer satisfaction	.446**	1.000							
3. Firm trust	.590**	.552**	1.000						
4. Firm loyalty intentions	.376**	.362**	.517**	1.000					
5. Social rapport	.261**	.197**	.387**	.256**	1.000				
6. Staff trust	.526**	.288**	.541**	.318**	.506**	1.000			
7. Staff loyalty intentions	.112**	.085	.267**	.202**	.519**	.339**	1.000		
8. Share-of-purchase intention	.039	.098	.135*	.236**	-.030	.055	.080	1.000	
9. Customer–firm affection	.440**	.102	.662**	.653**	.376**	.418**	.439**	.152**	1.000
M	3.83	6.82	3.81	3.57	2.73	3.50	2.14	3.13	3.24
SD	.56	1.35	.62	.82	.97	.79	.87	.78	.72
Construct (Hair Salon)	1	2	3	4	5	6	7	8	9
1. Service quality	1.000								
2. Customer satisfaction	.597**	1.000							
3. Firm trust	.675**	.495**	1.000						
4. Firm loyalty intentions	.608**	.475**	.596**	1.000					
5. Social rapport	.593**	.391**	.581**	.574**	1.000				
6. Staff trust	.730**	.498**	.678**	.638**	.634**	1.000			
7. Staff loyalty intentions	.579**	.391**	.592**	.619**	.643**	.687**	1.000		
8. Share-of-purchase intention	.328**	.234**	.226**	.315**	.160**	.237**	.203**	1.000	
9. Customer–firm affection	.680**	.472**	.708**	.749**	.683**	.725**	.697**	.229**	1.000
M	3.74	6.81	3.58	3.64	3.49	3.74	3.52	3.25	3.34
SD	.62	1.53	.70	.98	.89	.86	1.10	.88	.79

\* $p < .05$  (two-tailed).

\*\* $p < .01$  (two-tailed).



customer satisfaction, which has proved to be a valid indicator of a firm's past, current, and future performance (Bitner and Hubbert 1994). It contains a ten-point scale, anchored by "very dissatisfied" and "very satisfied," to measure the item, "Overall, how satisfied are you with the overall experience at this most often visited fast-food restaurant/hair salon?"

We adapted our firm trust items from the work of Morgan and Hunt (1994). The three-item scale captures three defining characteristics of this construct—namely, confidence in and reliability and integrity of the services provided. For firm loyalty intentions, most early studies conceptualized loyalty behaviorally as repeat purchasing of a particular product or service (e.g., Brown 1952); however, subsequent researchers have argued that a meaningful measure should include both attitude and behavior (e.g., Chaudhuri and Holbrook 2001; Oliver 1997). We followed Chaudhuri and Holbrook (2001) and used a three-item measure that includes both attitudinal and behavioral components of consumer loyalty.<sup>5</sup> Attitudinal loyalty describes liking and preferences for a specific fast-food restaurant/hair salon; it is similar to Oliver's (1997) notion of affective loyalty. Behavioral loyalty involves customers' behaviors to repatronize the same fast-food restaurant/hair salon in the future; it resembles Oliver's (1997) notion of conative loyalty. Although these similarities seem logical, drawing such comparisons is exploratory and post hoc, and further research should delineate the factors that describe the loyalty construct. To measure customer-firm affection, we adapted items from Sternberg's (1988) triangular love scale to fit the contexts of fast-food restaurant and hair salon. Some intimacy and passion items also build on extant measures of brand attachment (Carroll and Ahuvia 2006; Thomson, MacInnis, and Park 2005). We treated the construct as a second-order factor with three first-order indicators (each indicator encompasses three items): intimacy, passion, and commitment. Because of the complexity of our model, we treated customer-firm affection (second-order factor) as a latent factor with summated first-order indicators.<sup>6</sup> Given the measurement validity of the customer-firm affection scale, this treatment could reduce model complexity for structural model analysis and hypotheses testing (Anderson and Gerbing 1988).

We adapted the six-item social rapport scale from the work of Gremler and Gwinner (2000) to capture two dimensions of social rapport: personal connection and enjoyable interaction. For staff trust, we modified items from the work of Crosby, Evans, and Cowles (1990) and Morgan and Hunt (1994) and measured respondents' trust in the service staff with three items that capture their perceived reliability, confidence, and integrity. We also modified Chaudhuri and Holbrook's (2001) three-item measure

of firm loyalty to reflect consumers' staff loyalty intentions. These items capture the importance of the relationship to the respondent and his or her intention to maintain a long-term relationship with the staff. Finally, customers' share-of-purchase intention includes the item, "Assume that you will visit the [fast-food restaurant/hair salon] in the next two months [ten/five] times; how many times will you go to this most often visited [fast-food restaurant/hair salon]?"

## RESULTS

### *Validation of Measures*

We examine the validity of the measures in a two-step approach recommended by Anderson and Gerbing (1988). First, we conduct exploratory factor analysis to assess the underlying factor structure of the items.<sup>7</sup> Second, we assess the convergent and discriminant validity of the focal constructs by estimating the factor confirmatory measurement model for each service context. We find that the confirmatory factor models fit the data satisfactorily (fast food:  $\chi^2_{(195)} = 464$ ,  $p < .001$ ; goodness-of-fit index [GFI] = .90; comparative fit index [CFI] = .94; incremental fit index [IFI] = .94; and root mean square error of approximation [RMSEA] = .061; hair salon:  $\chi^2_{(195)} = 568$ ,  $p < .001$ ; GFI = .88; CFI = .94; IFI = .94; and RMSEA = .073), which suggests the unidimensionality of the measures. All factor loadings are highly significant ( $p < .001$ ), composite reliabilities of all constructs are greater than .75, and all average variance extracted (AVE) estimates (except hair salon firm trust) are greater than .50 (Fornell and Larcker 1981); therefore, the measures demonstrate adequate convergent validity and reliability.

Because validation of relationship marketing constructs remains preliminary (especially for relational services) and high correlations inherently exist among various relationship constructs (Garbarino and Johnson 1999; Morgan and Hunt 1994), a high level of discriminant validity likely will be difficult to attain. Therefore, we use three approaches to test the discriminant validity of all constructs in both service contexts. First, we find that the confidence interval around the correlation between any two latent constructs is significantly ( $p < .10$ ) less than |1.0|. Second, we run chi-square difference tests for all constructs in pairs to test whether the restricted model (correlation fixed at 1) is significantly worse than the freely estimated model (correlation estimated freely). All chi-square differences are significant, in support of discriminant validity. Third, we examine Fornell and Larcker's (1981) criterion that the shared variance between all possible pairs of constructs should be lower than the AVE for the individual constructs. For each

<sup>5</sup>Our measure does not include referral, because the contention that referral is a strong indicator of loyalty intentions remains controversial. Reichheld (2003) advocates the use of a single measure of customer referral to measure and manage customer relationships, whereas Morgan and Rego (2006) find that metrics based on referral intentions or behaviors have little or no predictive value for future business performance.

<sup>6</sup>The coefficient paths of the three summated first-order indicators are as follows: fast-food restaurant—intimacy (.899), passion (.876), and commitment (.736); hair salon—intimacy (.873), passion (.905), and commitment (.839).

<sup>7</sup>We subject all multi-item constructs (six constructs with 22 items for fast food and six constructs with 20 items for hair salons) to maximum likelihood exploratory factor analysis (using oblique rotation) for each service context. For fast food, the results indicate a six-factor solution that explains 71.47% of the variance, and all items load on the appropriate factor; the two cross-loadings greater than .35 are deleted from further analysis. For the hair salon, the results indicate a five-factor solution that explains 72.89% of the variance, and all items load on the appropriate factor, except for firm trust and employee trust, which load on the same factor. To ensure maximum comparability across samples and because of our strong theoretical support for the differential effects of employee trust and firm trust, we retain them as separate constructs and subject them to further analyses.

construct, the AVE is greater than its highest shared variance with other constructs in both service contexts, except for firm trust and staff trust in the hair salon context. In conclusion, all constructs in the fast-food context and most constructs in the hair salon context pass all three tests of discriminant validity, and all of them pass at least two tests. Following recommended practices in relationship literature (e.g., Baker et al. 2002; Garbarino and Johnson 1999), we consider the discriminant validity requirement reasonably well met by our constructs.

In summary, the measurement models fit the data well and demonstrate adequate reliability, good convergence, and acceptable discriminant validity. Although the hair salon model could have been improved by merging the firm trust and staff trust constructs, we use the same measurement models for both service contexts to ensure maximum comparability (for a similar approach, see Garbarino and Johnson 1999).<sup>8</sup> Because our analysis uses only data collected from customer self-reports, we also assess the extent of common methods bias; it is not a concern with our data.<sup>9</sup>

<sup>8</sup>We conduct another two-step approach to analyze the construct of customer-firm affection. The measurement model of the construct achieves a good fit, and the GFI, CFI, and IFI of the measurement model for fast food ( $\chi^2_{(17)} = 54, p < .01$ ) are .96, .97, and .97, respectively. For the hair salon ( $\chi^2_{(17)} = 48, p < .01$ ), the model demonstrates adequate fit: GFI = .97, CFI = .98, and IFI = .98. We assess the discriminant validity of customer-firm affection with chi-square difference tests and find that all chi-square differences are highly significant (e.g., fast-food social rapport and firm love:  $\chi^2_{\text{diff}(1)} = 51.02, p < .001$ ), in support of discriminant validity (Anderson and Gerbing 1988). All cross-construct correlation coefficients are significantly ( $p < .10$ ) less than |1.0|. Overall, the measure of customer-firm affection possesses adequate reliability and validity.

<sup>9</sup>We examine the impact of common methods bias by estimating our model with a "same-source" first-order factor added to the construct indicators (Podsakoff et al. 2003). Detailed descriptions of the model compari-

### Hypothesis Testing

To test the hypotheses, we employ structural equation modeling with the maximum likelihood estimation method, with Figure 1 as a base model. We provide the results of the model estimation for both fast-food restaurants and hair salons in Table 3 and Figure 2.

*Extant model of customer-firm and customer-staff relationships.* Our results confirm the extant model of customer-firm and customer-staff relationships in both service contexts, except that the direct effect of staff trust on staff loyalty is not significant in the fast-food context, though it fits our hypothesized direction. As we show in Table 3, service quality perceptions and customer satisfaction built through product and service experience, in parallel to the personal relationship developed through social rapport with staff, significantly contribute to the development of trust, which has a significant impact on customer loyalty (and share of purchase). This model seems appropriate as a basis for further analysis.

*Model extension 1: cross-level transfer (customer-staff to customer-firm level).* As Table 3 reveals, affect transfer occurs from the customer-staff to the customer-firm level. Consistent with our hypotheses, customers' trust and loyalty toward the staff directly influence their firm trust and loyalty, respectively, with one exception. Namely, the effect of staff loyalty intentions on firm loyalty intentions is not significant (though it is in the hypothesized direction) in the fast-food context. This result is reasonable because staff play a relatively minor role and represent less salient indicators of service quality for fast-food than for hairstyling

son and results appear in the Web Appendix (<http://www.marketingpower.com/jmrdec08>).

Table 3  
STANDARDIZED STRUCTURAL EQUATION PARAMETER ESTIMATES (t-VALUES)

Hypothesized Paths	Fast-Food Restaurant	Hair Salon
Service quality → customer satisfaction	.423*** (8.534)	.545*** (9.547)
Service quality → firm trust	.257*** (5.571)	.248*** (3.946)
Social rapport → service quality	.289*** (5.078)	.647*** (13.200)
Social rapport → customer satisfaction	.078* (1.459)	.080* (1.467)
Social rapport → staff trust	.547*** (7.807)	.566*** (10.817)
Social rapport → staff loyalty intentions	.538*** (6.437)	.159** (2.227)
Customer satisfaction → firm trust	.309*** (6.723)	.115** (2.339)
Customer satisfaction → firm loyalty intentions	.045 (.734)	.155** (3.104)
Staff trust → firm trust	.283*** (5.497)	.476*** (6.571)
Firm trust → firm loyalty intentions	.242** (2.696)	.282** (3.034)
Staff trust → staff loyalty intentions	.004 (.051)	.435*** (4.404)
Staff loyalty intentions → firm loyalty intentions	-.064 (-1.096)	.207** (2.795)
Staff loyalty intentions → share-of-purchase intention	-.064 (-1.093)	.116 (1.182)
Firm loyalty intentions → share-of-purchase intention	.277*** (4.740)	.427** (4.138)
Service quality → customer-firm affection	.299*** (5.502)	.578*** (10.132)
Customer satisfaction → customer-firm affection	.262*** (4.815)	.061 (1.126)
Customer-firm affection → firm trust	.338*** (6.610)	.212*** (3.368)
Customer-firm affection → firm loyalty intentions	.510*** (6.779)	.416*** (5.549)
Customer-firm affection → staff trust <sup>a</sup>	.270*** (4.768)	.425*** (8.664)
Customer-firm affection → staff loyalty intentions <sup>a</sup>	.292*** (4.960)	.339*** (5.345)

Model fit: Fast-food restaurant:  $\chi^2_{(211)} = 575, p < .001$ ; GFI = .88; CFI = .91; IFI = .91; and RMSEA = .069.

Hair salon:  $\chi^2_{(211)} = 688, p < .001$ ; GFI = .86; CFI = .92; IFI = .92; and RMSEA = .079.

\* $p < .10$ .

\*\* $p < .01$ .

\*\*\* $p < .001$ .

<sup>a</sup>Structural path indicated by the modification index is included.

Notes: t-tests are one-tailed for hypothesized effects.

Figure 2  
GRAPHICAL PRESENTATION OF STRUCTURAL EQUATION MODELING RESULTS

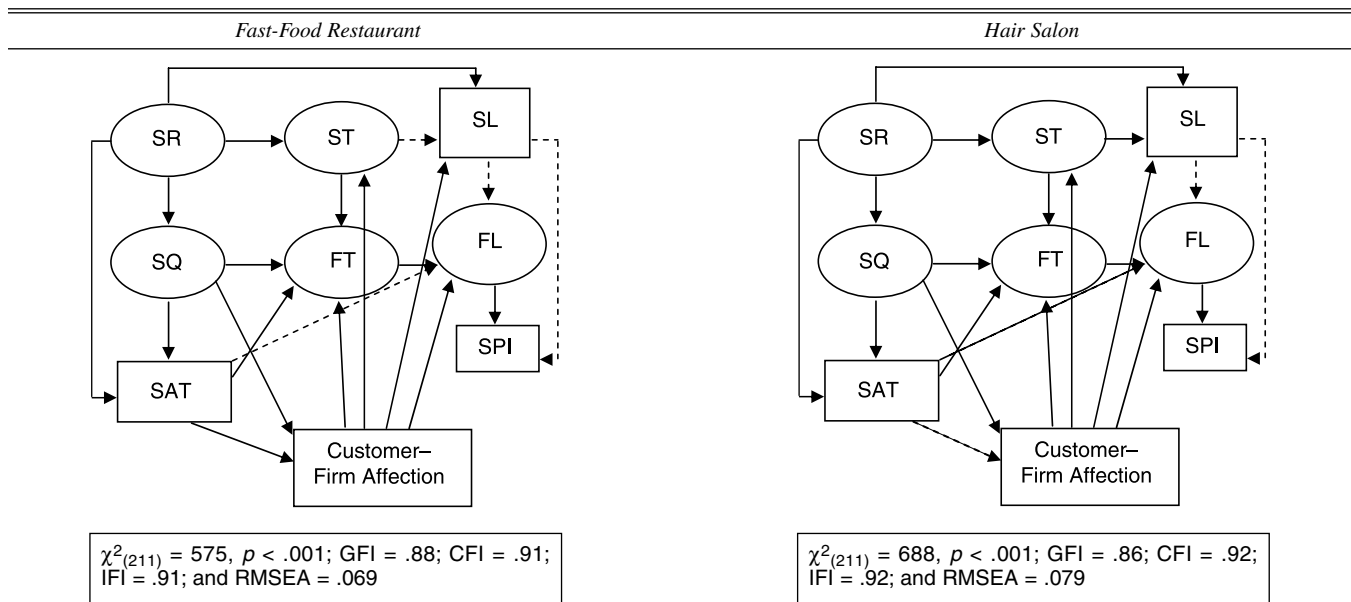

Notes: Solid arrows denote significant relationships; dotted arrows denote insignificant relationships. SR = social rapport, ST = staff trust, SL = staff loyalty intentions, SQ = service quality, FT = firm trust, FL = firm loyalty intentions, SAT = customer satisfaction, and SPI = share-of-purchase intention.

services. Overall,  $H_{1a}$  in both service contexts and  $H_{1b}$  in the hair salon context are supported.

*Model extension 2: mediating role of customer-firm affection.* Following the work of Baron and Kenny (1986), we test the mediating effect of customer-firm affection. In Step 1, we test whether customer-firm affection has a significant influence on firm trust and firm loyalty. In Step 2, we assess the impact of service quality and customer satisfaction on firm trust and firm loyalty. In Step 3, we regress these antecedent predictors on customer-firm affection. Finally, in Step 4, we test whether the influences of antecedent predictors lessen (or become insignificant) when we include customer-firm affection in the model. Complete (partial) mediation occurs when including the variable eliminates (reduces) the significant influence of the antecedent predictors from Step 2.

We use multiple regressions in the four-step testing procedure. To determine whether the influence of antecedent predictors decreases between Steps 2 and 4, we examine changes in the beta coefficient and  $p$ -values. Consistent with  $H_2$ , customer-firm affection mediates the effects of service quality and customer satisfaction on firm trust and firm loyalty. Of all the mediation tests in both service contexts, only one (effect of customer satisfaction on firm loyalty in the fast-food context) implies a full mediation effect of customer-firm affection; the remaining test results suggest a partial mediating effect (for details, see the Web Appendix at <http://www.marketingpower.com/jmrdec08>).<sup>10</sup>

In addition to testing the mediating effect of customer-firm affection, we conduct further nested model compari-

sons (Sapienza and Korsgaard 1996) and hierarchical regression analyses to assess the incremental contribution of passion and intimacy, after controlling for the effect of commitment, in terms of R-square change and effect size. The results of the R-square change and effect size assessment suggest that all three constituent components of customer-firm affection contribute substantially to the improvement in the fit of our proposed model. We present details of the analyses and results in the Web appendix (<http://www.marketingpower.com/jmrdec08>).

After we add customer-firm affection, the modification indexes reveal two potential links from customer-firm affection to staff trust and staff loyalty. When we include these paths, the chi-square statistics drop significantly. Following similar approaches used in the literature (e.g., Baker et al. 2002), we add these two links to our model.

*Model extension 3: relationship formation in transactional and relational services.* When we test for differences in the geometry (area and nature) of affection across the two service contexts, we find that the area of the affection triangle is significantly larger on average for hair salons than for fast-food restaurants, which suggests that customers maintain more intimate, passionate, and committed relationships with hair salons than with fast-food restaurants, though the difference in the amount of passion is not significant.<sup>11</sup> Thus, we find support for  $H_{3a}$ .

Regarding the nature of affection, we find differences between the two services. Passion is significantly stronger than commitment for fast food (3.07 versus 2.91;  $t(359) =$

<sup>10</sup>In addition to using regressions to test the mediation, we conduct nested model comparisons, as is often adopted in causal model analysis (e.g., Sapienza and Korsgaard 1996). The results are the same as those revealed by regressions, in support of our proposed partially mediated model.

<sup>11</sup>We use paired sample  $t$ -tests to examine the differences between the mean ratings of the three components of customer-firm affection for fast-food restaurants and hair salons: intimacy (hair salon<sub>mean</sub> = 3.83, fast food<sub>mean</sub> = 3.74;  $t(359) = 1.839, p < .10$ ), commitment (hair salon<sub>mean</sub> = 3.27, fast food<sub>mean</sub> = 2.91;  $t(359) = 6.788, p < .001$ ), and passion (hair salon<sub>mean</sub> = 3.08, fast food<sub>mean</sub> = 3.07;  $t(359) = .091, p > .10$ ).

4.001,  $p < .001$ ), whereas commitment is significantly stronger than passion for hair salons (3.27 versus 3.08;  $t(359) = 5.181$ ,  $p < .001$ ). As we expected, intimacy receives the highest ratings among the three components in both service contexts.<sup>12</sup> Thus, these findings provide some support for H<sub>3b</sub>: Consumers of relational services experience commitment-dominant customer–firm affection, whereas those of transactional services develop passion-dominant customer–firm affection.

We use a multisample analysis to test our hypotheses regarding the relative strength of affect transfers from the customer–staff to the customer–firm level. As we stipulate in H<sub>3c</sub> and H<sub>3d</sub>, the influences of consumers' staff trust and loyalty on trust and loyalty toward the firm should be stronger for hair salons than for fast-food restaurants. We conduct moderation tests to determine whether the strength of the paths from staff trust to firm trust and from staff loyalty to firm loyalty is greater in the hair salon than in the fast-food context. We run two models in which we first leave all paths unconstrained to create our baseline model and then constrain the path from staff trust to firm trust to be equal for both subsamples to create the equal path model. The difference in chi-square values between the two models with a single degree of freedom tests the equality of the path for the two services. This difference is not significant ( $\chi^2_{\text{diff}}(1) = .10$ ,  $p > .10$ ), so H<sub>3c</sub> is not supported. We use the same procedures for the causal path from staff loyalty to firm loyalty and find that the affect transfer from staff loyalty to firm loyalty is significantly stronger in the hair salon than in the fast-food context ( $\chi^2_{\text{diff}}(1) = 3.79$ ,  $p < .05$ ), in support of H<sub>3d</sub>. Thus, the potential double-edged sword effect is more likely in relational services.<sup>13</sup>

### DISCUSSION AND IMPLICATIONS

To understand what drives customers to be loyal, we gather substantial contributions from extant service quality and satisfaction studies, as well as emerging work on customer trust. The former indicates that consumers' postconsumption evaluations represent core, consumption-based evaluations that drive consumer loyalty. Studies of trust confirm that consumers engage in cognitive-based assessments of how a brand or firm may perform in the future. These studies initiate a multiprocess paradigm for understanding how loyalty evolves. Our study provides yet another approach that considers strong, affectionate bonds between customers and service firms. We use two service contexts to examine the roles of this bond for building customer loyalty. Using the construct of customer–firm affec-

tion, we assess how the bond emerges and influences customer loyalty in service contexts, as well as how it relates to satisfaction and firm trust. Our study also addresses the role and effects of customer–staff relationships.

Several findings from this study deserve further discussion. First, customer–firm affection complements satisfaction and trust in affecting customer loyalty; each exerts significant direct effects. Customer–firm affection also mediates the effect of satisfaction on firm trust and firm loyalty, which suggests that it is driven by satisfaction (and service quality) and substantiates the evaluative base model of emotional elicitation. In addition to postconsumption evaluative (captured by satisfaction) and cognitive reasoning (captured by trust) processes, emotionally laden processes driven by affection deserve greater consideration. This finding reasserts the need for a multiprocess paradigm for understanding consumer loyalty.

Second, Sternberg's (1986) triangular theory of love and its constituent components apply to exemplary services on the transactional–relational continuum. The three components provide insights into the complexity of affectionate bonds, as reflected in the geometry of affection. In general, relational services exhibit a greater amount of affection than transactional services. As to the nature of customer–firm affection, relational services tend to be commitment driven, whereas transactional services are more passion driven. This finding can help managers develop loyalty enhancement programs for different types of services.

The term "love" is often reserved for the most meaningful relationships with a selected few people. Yet our netnography study reveals that consumers freely believe that they love a store or brand. Do they actually form a relationship with stores or brands that resemble romantic love with a person? According to Whang and colleagues (2004), bikers' bonds with their motorcycles resemble interpersonal love that is passionate, possessive, and selfless in nature; the passion component of this bond influences loyalty to the bikes. Similarly strong affectionate bonds appear to exist between some consumers and their favorite brands. We believe that Sternberg's theory of love is a useful and encompassing metaphor that helps describe consumers' lovelike bonds with firms, products, brands, and people. However, no matter how strong the bond, a customer will not visit the same fast-food outlet consistently for months because of the natural need for variety in fast foods. In this case, love consists mainly of intimacy (similar to connectedness in a friendship) and may be passionate (e.g., excitement about a new menu), but commitment is not necessary. In contrast, a customer likely goes to the same hair salon and stylist on consecutive visits. This love relationship may begin with intimacy and gradually become a long-term committed relationship or companionate love that features both intimacy and commitment.

Third, our study reveals that the salience of affect transfers from the customer–staff to the customer–firm level differs in various domains or contexts. For example, customer–staff relationships affect customer–firm relationships in the hair salon but not in the fast-food context, indicating that the "rub-off effect" of positive customer–staff relationships may not occur in transactional services. Customers develop a loyalty to a hair salon because of their loyalty to hairstylists, who function as prominent firm

<sup>12</sup>Hair salon (intimacy > commitment,  $t(359) = 14.059$ ,  $p < .001$ ; intimacy > passion,  $t(359) = 20.193$ ,  $p < .001$ ); fast food (intimacy > commitment,  $t(359) = 18.866$ ,  $p < .001$ ; intimacy > passion,  $t(359) = 17.023$ ,  $p < .001$ ).

<sup>13</sup>To assess the double-edged sword dilemma, we use paired sample *t*-tests to examine the differences between the mean ratings of staff loyalty intentions, particularly the item "You will consider following this staff [hair stylist] to switch to another restaurant [hair salon]." Relative to transactional services, customers of relational services are more likely to develop stronger staff loyalty intentions and greater switching intentions if the staff member were to leave the firm (staff loyalty: hair salon<sub>mean</sub> = 3.52, fast food<sub>mean</sub> = 2.14;  $t(359) = 21.319$ ,  $p < .001$ ; switching: hair salon<sub>mean</sub> = 3.19, fast food<sub>mean</sub> = 1.65;  $t(359) = 18.345$ ,  $p < .001$ ).

agents and whose performance represents a key characteristic of the service, but in fast-food contexts, staff play a minor role and contribute less to service quality. Therefore, the double-edged sword effect may be relevant only for relational services. Even so, cultivating customer–staff relationships should be viewed as a high-risk, high-return decision that demands consideration of the specific service context.

Fourth, beyond these differences, we note that the proposed causal paths (15 for fast food and 18 for hair salons) are significant for both services. Although the size of the coefficients may differ because of the contexts, their consistent salience suggests that our model is reasonably parsimonious and that there are more commonalities across services than we may realize.

Our findings also provide several strategic implications for managing service loyalty. Currently, most service loyalty programs follow the satisfaction paradigm: Monitor satisfaction levels, reduce service failures, and promote programs to “lock in” customers. Our study suggests another path: Enhance customer–firm affection by adding excitement to the service delivered. Such efforts could alleviate some of the problems associated with current customer relationship management programs (Fournier, Dobscha, and Mick 1998).

However, our findings also suggest that building loyalty requires cultivating affectionate ties that comprise both intimacy and passion. If we benchmark service loyalty against loyalty toward famous global brands, such as Louis Vuitton and Armani, it becomes clear what has been lacking. These global brands command strong passion and love among customers, to the extent that even paper bags with their logos get auctioned off on Web sites (e.g., [www.yahoo.com.hk](http://www.yahoo.com.hk)) in some Asian markets. Without exception, these brands invest heavily and effectively in promoting customer passion. In contrast, most service firms eliminate peripherals from their service offerings to increase profits, often stripping service bundles down to “naked offerings.” By now, fewer people feel excited about flying with U.S. airlines, whereas Asian carriers continue to upgrade economy cabins by offering Häagen-Dazs ice cream, full dinner sets, current newspapers and magazines, and dozens of movie channels—and then receive higher passenger ratings and command a higher price premium than U.S. counterparts for the same trans-Pacific routes. The neglect of passion also harms attractions, such as the Hard Rock Café and McDonald’s; these once “must-go” places seem to have lost some of their glamour in the world market. Of the six million Mainland Chinese tourists who visited Hong Kong in 2006, only 20% visited Hong Kong Disneyland (Pomfret 2006).

Managers of relational services should pay particular attention to cultivating intimacy to maintain highly committed relationships with customers. Credit cards that rely on excitement-oriented promotions with extravagant sign-up prizes to gain new customers often find out that a stable and committed share of the consumers’ purchases is what really matters in the end. For some health clubs that promote excitement and then gain customer commitment through

longer-term binding contracts, the situation is worse. When the passion fades—as it almost inevitably does—all that is left is a contract, not a commitment that lasts.

The positive findings for affect transfer suggest that strong customer–staff relationships benefit customer–firm relationships. Driven by an unnecessary fear of the hostage effect, most firm strategies tend to be conservative. In reality, staff from top-end service firms seldom leave, let alone take their customers along. Instead, they stay with their firms because of the nice service environment, well-mannered customers, and efficient service systems. Ritz-Carlton’s slogan—“ladies and gentlemen serving ladies and gentlemen”—attracts both customers and staff. When a staff member with a strong sense of customer loyalty wants to leave, it is more likely due to something fundamentally wrong with the service. Cutting off customer–staff relationships is unnatural and may perpetuate a new service error. Similarly, many banks that have been pushing their customers to use ATMs, online banking, and automated phone services rather than contacts with employees may reduce service costs but also may give up an opportunity to differentiate themselves by building emotional connections with their customers (McEwen 2005).

Firms’ intentions to standardize services and develop good social rapport simultaneously may backfire. When a fast-food employee says, “Hope to see you again,” it often means, “Move away! I need to serve the next customer.” When convenience store attendants say “hello” or “thank you” to customers, it suggests indoctrination by the training manual, not sincerity. The salience of intimacy indicates that firms must restrategize or redesign their customer–staff interactions, just as Cathay Pacific has launched a program that stresses “serving from our heart” to rejuvenate the firm’s customer intimacy.

Several limitations in our study suggest further research opportunities. First, although we successfully demonstrate the salience of customer–firm affection, additional work is needed to uncover the differential effects of its components and their relative roles in various services. Second, the way customer–firm affection operates offers a challenge for both theory and methodological design. For example, it may return some of the credit for strong customer–staff relationships to the firm. Third, we assume a bilevel (consumer–staff and consumer–firm) approach, but the consumer–consumer level demands more explication. Fourth, our model assumes a cross-sectional approach, but a dynamic approach would be useful for assessing both the dynamic and the cumulative effects of the link between customer–staff and customer–firm relational levels. Analogous to interpersonal relationships, customer–firm relationships almost inevitably are dynamic: Passion fades, and intimacy gets challenged. Therefore, service firms must work constantly to understand, build, and then rebuild affectionate relationships with customers. We cannot expect such relationships to take care of themselves, any more than we can expect that of interpersonal relationships. Rather, firms must strive to make affectionate relationships with customers the best they can be.

Appendix  
MEASUREMENT ITEMS AND VALIDITY ASSESSMENT

	<i>Standardized Factor Loading</i>	
	<i>Fast-Food Restaurant</i>	<i>Hair Salon</i>
<i>Service Quality:</i> CR <sub>FF</sub> = .84, AVE <sub>FF</sub> = .51; CR <sub>HS</sub> = .88, AVE <sub>HS</sub> = .60		
1. The staff (hair stylist) always tries to meet your needs.	.623	.787
2. The food (product) quality of this restaurant (hair salon) is good.	.311	.263
3. The staff provides prompt service in taking order and payment. The hair stylist is responsive to your questions and requests.	.748	.915
4. The staff provides accurate service in taking order and payment. The hair stylist provides reliable hair cutting service.	.752	.715
5. The staff (hair stylist) is consistently courteous with you.	.738	.661
<i>Customer Satisfaction:</i>		
1. Overall, how satisfied are you with the overall experience at this restaurant (hair salon)?		
<i>Firm Trust:</i> CR <sub>FF</sub> = .85, AVE <sub>FF</sub> = .60; CR <sub>HS</sub> = .78, AVE <sub>HS</sub> = .47		
1. You are confident about the food (product) quality provided at this restaurant (hair salon).	.713	.634
2. This restaurant provides reliable services. This hair salon provides reliable and professional services.	.753	.742
3. This restaurant (hair salon) has high integrity.	.756	.705
4. Overall, you can confidently rely on this restaurant (hair salon) for service.	.858	.666
<i>Firm Loyalty Intentions:</i> CR <sub>FF</sub> = .79, AVE <sub>FF</sub> = .57; CR <sub>HS</sub> = .86, AVE <sub>HS</sub> = .68		
1. You consider this your first choice when choosing a fast-food restaurant (hair salon).	.812	.866
2. This is the fast-food restaurant (hair salon) that you prefer over others.	.870	.922
3. You would continue to visit this restaurant (hair salon) even if it increases price.	.542	.654
<i>Social Rapport:</i> CR <sub>FF</sub> = .83, AVE <sub>FF</sub> = .56; CR <sub>HS</sub> = .90, AVE <sub>HS</sub> = .70		
1. You look forward to seeing this staff (hair stylist) when you visit this restaurant (hair salon).	.732	.873
2. Chatting with this staff (hair stylist) is enjoyable.	.816	.827
3. You can have a nice conversation with this staff (hair stylist).	.623	.904
4. You don't mind to be friend with this staff (hair stylist).	.806	.730
<i>Staff Trust:</i> CR <sub>FF</sub> = .75, AVE <sub>FF</sub> = .50; CR <sub>HS</sub> = .81, AVE <sub>HS</sub> = .59		
1. You are confident about the service provided by this staff (hair stylist).	.722	.867
2. This staff's (hair stylist's) opinion is honest and reliable.	.685	.718
3. This staff (hair stylist) is a person you can trust.	.718	.697
<i>Staff Loyalty Intentions:</i> CR <sub>FF</sub> = .77, AVE <sub>FF</sub> = .54; CR <sub>HS</sub> = .87, AVE <sub>HS</sub> = .70		
1. You will choose to be served by this staff (hair stylist).	.769	.730
2. You'd like to have this staff (hair stylist) continued to work here.	.845	.889
3. You will consider following this staff (hair stylist) to switch to another restaurant (hair salon).	.549	.871
<i>Share-of-Purchase Intention:</i>		
1. Assuming you will make 10 visits to fast-food restaurants (5 visits to hair salons) in the next two months, how many times will you go to this fast-food restaurant (hair salon)?		
<i>Customer-Firm Affection:</i> second-order factor: CR <sub>FF</sub> = .86, AVE <sub>FF</sub> = .68; CR <sub>HS</sub> = .89, AVE <sub>HS</sub> = .73		
<i>Intimacy:</i> first-order factor, CR <sub>FF</sub> = .87, AVE <sub>FF</sub> = .68; CR <sub>HS</sub> = .91, AVE <sub>HS</sub> = .77		
1. You always enjoy your experience at this restaurant (hair salon).	.756	.777
2. You always have a warm and comfortable feeling when visiting this restaurant (hair salon).	.813	.921
3. You experience great happiness with visiting this restaurant (hair salon).	.827	.884
	.841	.816
<i>Passion:</i> first-order factor, CR <sub>FF</sub> = .85, AVE <sub>FF</sub> = .68; CR <sub>HS</sub> = .87, AVE <sub>HS</sub> = .68		
1. You will never get bored of going to this fast-food restaurant (hair salon).	.912	.929
2. You find yourself always thinking about visiting this restaurant (hair salon).	.788	.782
3. You adore this restaurant (hair salon).	.829	.876
	.800	.815
<i>Commitment:</i> first-order factor, CR <sub>FF</sub> = .80, AVE <sub>FF</sub> = .58; CR <sub>HS</sub> = .83, AVE <sub>HS</sub> = .61		
1. You care about maintaining your relationship with this restaurant (hair salon).	.789	.848
2. You have decided that this is "your" restaurant (hair salon).	.705	.804
3. You could not let anything get in the way of your commitment to this restaurant (hair salon).	.848	.779
	.718	.765
Overall model fit: Fast food: $\chi^2_{(195)} = 452, p < .001$ ; GFI = .90; CFI = .94; IFI = .94; and RMSEA = .061. Hair salon: $\chi^2_{(195)} = 568, p < .001$ ; GFI = .88; CFI = .94; IFI = .94; and RMSEA = .073.		

Notes: CR = composite reliability.

## REFERENCES

- Agustin, Clara and Jagdip Singh (2005), "Curvilinear Effects of Consumer Loyalty: Determinants in Relational Exchanges," *Journal of Marketing Research*, 42 (February), 96–108.
- Ahuvia, Aaron (2005), "Beyond the Extended Self: Loved Objects and Consumers' Identity Narratives," *Journal of Consumer Research*, 32 (1), 171–84.
- Ainsworth, Mary D.S. (1973), "The Development of Infant-Mother Attachment," in *Review of Child Development Research*, B.M. Caldwell and H.N. Ricciuti, eds. Chicago: University of Chicago Press, 1–94.
- Anderson, James C. and David W. Gerbing (1988), "Structural Equation Modeling in Practice: A Review and Recommended Two-Step Approach," *Psychological Bulletin*, 103 (3), 411–23.
- Baker, Julie, A. Parasuraman, Dhruv Grewal, and Glenn B. Voss (2002), "The Influence of Multiple Store Environment Cues on Perceived Merchandise Value and Patronage Intentions," *Journal of Marketing*, 66 (April), 120–41.
- Ball, A. Dwayne and Lori H. Tasaki (1992), "The Role and Measurement of Attachment in Consumer Behavior," *Journal of Consumer Psychology*, 1 (2), 155–72.
- Bansal, Harvir S., P. Geogery Irving, and Shirley F. Taylor (2004), "A Three-Component Model of Customer Commitment to Service Providers," *Journal of the Academy of Marketing Science*, 32 (3), 234–50.
- Baron, R.M. and D.A. Kenny (1986), "The Moderator-Mediator Variable Distinction in Social Psychological Research: Conceptual, Strategic and Statistical Considerations," *Journal of Personality and Social Psychology*, 51 (6), 1173–82.
- Beatty, Sharon E., Morris Mayer, James E. Coleman, Kristy E. Reynolds, and Jungki Lee (1996), "Customer-Sales Associate Retail Relationships," *Journal of Retailing*, 72 (3), 223–47.
- Bell, Chip (2000), *Customer Love: Attracting and Keeping Customer for Life*. Provo, UT: Executive Excellence.
- Bendapudi, Neeli and Robert P. Leone (2002), "Managing Business-to-Business Customer Relationships Following Key Contact Employee Turnover in a Vendor Firm," *Journal of Marketing*, 66 (April), 83–101.
- Berry, Leonard L. (1995), *On Great Service: A Framework for Action*. New York: The Free Press.
- Bitner, Mary J., Bernard H. Booms, and Mary S. Tetrault (1990), "The Service Encounter: Diagnosing Favorable and Unfavorable Incidents," *Journal of Marketing*, 54 (January), 71–84.
- and Amy R. Hubbert (1994), "Encounter Satisfaction Versus Overall Satisfaction Versus Quality: The Customer's Voice," in *Service Quality: New Directions in Theory and Practice*, Roland T. Rust and Ruth L. Oliver, eds. Thousand Oaks, CA: Sage Publications, 72–94.
- Bolton, Ruth N. (1998), "A Dynamic Model of the Duration of the Customer's Relationship with a Continuous Service Provider: The Role of Satisfaction," *Marketing Science*, 17 (1), 45–65.
- , Amy K. Smith, and Janet Wagner (2003), "Striking the Right Balance: Designing Service to Enhance Business-to-Business Relationships," *Journal of Service Research*, 5 (4), 271–91.
- Bowen, J. (1990), "Development of a Taxonomy of Services to Gain Strategic Marketing Insights," *Journal of the Academy of Marketing Science*, 18 (Winter), 43–49.
- Bowlby, John (1969), *Attachment and Loss*, Vol. 1. New York: Basic Books.
- Branden, N. (1988), "A Vision of Romantic Love," in *The Psychology of Love*, R.J. Sternberg and M.L. Barnes, eds. New Haven, CT: Yale University Press, 218–31.
- Brehm, S.S. (1988), "Passionate Love," in *The Psychology of Love*, R.J. Sternberg and M.L. Barnes, eds. New Haven, CT: Yale University Press, 232–63.
- Brown, George H. (1952), "Brand Loyalty—Fact or Fiction?" *Advertising Age*, 23 (June), 32–35.
- Buss, David M. (1988), "Love Acts: The Evolutionary Biology of Love," in *The Psychology of Love*, R.J. Sternberg and M.L. Barnes, eds. New Haven, CT: Yale University Press, 100–118.
- Butcher, K.J., B. Sparks, and F. O'Callaghan (2002), "Effect of Social Influence on Repurchase Intentions," *Journal of Services Marketing*, 16 (6), 503–514.
- Carroll, Barbara A. and Aaron Ahuvia (2006), "Some Antecedents and Outcomes of Brand Love," *Marketing Letters*, 17 (2), 79–89.
- Chaudhuri, A. and Morris B. Holbrook (2001), "The Chain Effects from Brand Trust and Brand Affect to Brand Performance: The Role of Brand Loyalty," *Journal of Marketing*, 65 (April), 81–93.
- Crosby, Lawrence A., Kenneth R. Evans, and Deborah Cowles (1990), "Relationship Quality in Services Selling: An Interpersonal Influence Perspective," *Journal of Marketing*, 54 (July), 68–81.
- Czepiel, John A. and Robert Gilmore (1987), "Exploring the Concept of Loyalty in Services," in *The Service Challenge: Integrating for Competitive Advantage*, C. Congram, J.A. Czepiel, and J. Shanahan, eds. Chicago: American Marketing Association, 91–94.
- Doney, Patricia M. and Joseph P. Cannon (1997), "An Examination of the Nature of Trust in Buyer–Seller Relationships," *Journal of Marketing*, 61 (April), 35–51.
- Dwyer, Robert F., Paul H. Schurr, and Sejo Oh (1987), "Developing Buyer–Seller Relationships," *Journal of Marketing*, 51 (April), 11–27.
- Edwards Helen and Derek Day (2005), *Creating Passion Brands: Why It's Time to Lead from the Heart*. London: Kogan Page.
- Emerson, Richard (1987), "Toward a Theory of Value in Social Exchange," in *Social Exchange Theory*, Karen S. Cook, ed. Beverly Hills, CA: Sage Publications, 11–46.
- Fehr, Beverley (1988), "Prototype Analysis of the Concepts of Love and Commitment," *Journal of Personality and Social Psychology*, 55 (4), 557–79.
- and J.A. Russell (1991), "The Concept of Love Viewed from a Prototype Perspective," *Journal of Personality and Social Psychology*, 60 (3), 425–38.
- Fleming, J.H., C. Coffman, and J.K. Harter (2005), "Manage Your Human Sigma," *Harvard Business Review*, 83 (7–8), 106–114.
- Fournier, Susan M. (1998), "Consumers and Their Brands: Developing Relationship Theory in Consumer Research," *Journal of Consumer Research*, 24 (4), 343–73.
- , Susan Dobscha, and David G. Mick (1998), "Preventing the Premature Death of Relationship Marketing," *Harvard Business Review*, 76 (January–February), 42–51.
- Fornell, Claes and David F. Larcker (1981), "Evaluating Structural Equation Models with Unobservable Variables and Measurement Error," *Journal of Marketing Research*, 18 (February), 39–50.
- Frijda, Nico H., Anthony S.R. Manstead, and Sacha Bem (2000), *Emotions and Beliefs: How Feelings Influence Thoughts*. Cambridge, UK: Cambridge University Press.
- Garbarino, Ellen and Mark S. Johnson (1999), "The Different Roles of Satisfaction, Trust, and Commitment in Customer Relationships," *Journal of Marketing*, 63 (April), 70–87.
- Gonzaga, Gian, Dacher Keltner, Esme Londahl, and Michael Smith (2001), "Love and the Commitment Problem in Romantic Relationships and Friendship," *Journal of Personality and Social Psychology*, 81 (2), 247–62.
- Gremler, Dwayne D. and Kevin P. Gwinner (2000), "Customer–Employee Rapport in Service Relationships," *Journal of Service Research*, 3 (August), 82–104.
- Gummesson, E. (1987), "The New Marketing—Developing Long-Term Interactive Relationships," *Long Range Planning*, 20 (4), 10–20.
- Hatfield, E. and G.W. Walster (1978), *A New Look at Love*. Reading, MA: Addison-Wesley.
- Hazan, Cindy and Phillip Shaver (1987), "Romantic Love Conceptualized as an Attachment Process," *Journal of Personality and Social Psychology*, 52 (3), 511–24.
- Hennig-Thurau, Thorsten and Alexander Klee (1997), "The Impact of Customer Satisfaction and Relationship Quality on Customer

- Retention: A Critical Reassessment and Model Development," *Psychology and Marketing*, 14 (December), 737–65.
- Hut, M. and T. Speh (1995), *Business Marketing Management*, 5th ed. New York: Dryden Press.
- Iacobucci, D. and A. Ostrom (1996), "Commercial and Interpersonal Relationships: Using the Structure of Interpersonal Relationships to Understand Individual-to-Individual, Individual-to-Firm, and Firm-to-Firm Relationships in Commerce," *International Journal of Research in Marketing*, 13 (1), 53–72.
- IBM Global Services (2006), "CRM: The Myth vs. the New Agenda," executive brief, (accessed March 23, 2006), [available at <http://www-1.ibm.com/services/us/index.wss/multipage/imc/executivebrief/a1008913/1?cntxt=a1005261>].
- Kasdan, Pamela (1996), "Food for Thought," *American Demographics*, 18 (May), 19.
- Kelley, Harold H. (1983), "Love and Commitment," in *Close Relationships*, H.H. Kelley, E. Berscheid, A. Christensen, J.H. Harvey, T.L. Huston, G. Levinger, et al., eds. New York: Freeman, 265–314.
- Krippendorff, K. (2004), *Content Analysis: An Introduction to Its Methodology*, 2d ed. Beverly Hills, CA: Sage Publications.
- Lewicki, Roy J. and Barbara B. Bunker (1995), "Trust in Relationships: A Model of Trust Development and Decline," in *Conflict, Cooperation, and Justice: Essays Inspired by the Work of Morton Deutsch*, B.B. Bunker and J.Z. Rubin, eds. San Francisco: Jossey-Bass, 133–73.
- Macintosh, Gerrard and Lawrence S. Lockshin (1997), "Retail Relationships and Store Loyalty: A Multi-Level Perspective," *International Journal of Research in Marketing*, 14 (5), 487–97.
- Macneil, Ian R. (1980), *The New Social Contract: An Inquiry into Modern Contractual Relations*. New Haven, CT: Yale University Press.
- McCracken, G. (1995), *Big Hair: A Journey to the Transformation of Self*. Toronto: Viking.
- McEwen, William J. (2005), *Married to the Brand: Why Consumers Bond with Some Brands for Life*. Princeton, NJ: Gallup Press.
- Morgan, Neil A. and Lopo Leotte Rego (2006), "The Value of Different Customer Satisfaction and Loyalty Metrics in Predicting Business Performance," *Marketing Science*, 25 (5), 426–39.
- Morgan, Rob M. and Shelby D. Hunt (1994), "The Commitment–Trust Theory of Relationship Marketing," *Journal of Marketing*, 58 (July), 20–38.
- Oliver, Richard L. (1980), "A Cognitive Model of the Antecedents and Consequences of Satisfaction Decisions," *Journal of Marketing Research*, 17 (November), 460–69.
- (1997), *Satisfaction: A Behavioral Perspective on the Consumer*. Boston: Richard D. Irwin.
- Palmatier, Rob, Lisa K. Scheer, and Jan-Benedict E.M. Steenkamp (2007), "Customer Loyalty to Whom? Managing the Benefits and Risks of Salesperson-Owned Loyalty," *Journal of Marketing Research*, 44 (May), 185–99.
- Parasuraman, A., Valarie A. Zeithaml, and Leonard L. Berry (1988), "Communication and Control Process in the Delivery of Service Quality," *Journal of Marketing*, 52 (April), 35–48.
- Park, C. Whan, Deborah J. MacInnis, and Joseph Priester (2006), "Beyond Attitudes: Attachment and Consumer Behavior," *Seoul Journal of Business*, 12 (2), 3–35.
- Podsakoff, Philip M., Scott B. MacKenzie, Jeong-Yeon Lee, and Nathan P. Podsakoff (2003), "Common Method Biases in Behavioral Research: A Critical Review of the Literature and Recommended Remedies," *Journal of Applied Psychology*, 88 (5), 879–903.
- Pomfret, James (2006), "Disneyland Struggles to Make Magic in Hong Kong," *Reuters News*, (September 12), [available at <http://sg.news.yahoo.com/060911/3/43c87.html>].
- Price, Linda L. and Eric J. Arnould (1999), "Commercial Friendship: Service Provider–Client Relationships in Context," *Journal of Marketing*, 63 (October), 38–56.
- Reichheld, Frederick F. (2003), "The One Number You Need to Grow," *Harvard Business Review*, 81 (December), 46–54.
- Reynolds, Kristy E. and Sharon E. Beatty (1999), "Customer Benefits and Company Consequence of Customer-Salesperson Relationships in Retailing," *Journal of Retailing*, 75 (1), 11–32.
- Saavedra, R. and L. Van Dyne (1999), "Social Exchange and Emotional Investment in Work Groups," *Motivation and Emotion*, 23 (2), 105–123.
- Sapienza, Harry J. and M. Audrey Korsgaard (1996), "Procedural Justice in Entrepreneur-Investor Relations," *Academy of Management Journal*, 39 (3), 544–74.
- Selnes, Fred (1998), "Antecedents and Consequences of Trust and Satisfaction in Buyer-Seller Relationships," *European Journal of Marketing*, 32 (3–4), 305–322.
- Shaver, Philip R., J. Schwartz, D. Kirson, and C. O'Connor (1987), "Emotion Knowledge: Further Exploration of a Prototype Approach," *Journal of Personality and Social Psychology*, 52 (6), 1061–86.
- Sheth, Jagdish N. and Atul Parvatiyar (1995), "The Evolution of Relationship Marketing," *International Business Review*, 4 (4), 397–418.
- Shimp, Terence A. and Thomas J. Madden (1988), "Consumer-Object Relations: A Conceptual Framework Based Analogously on Sternberg's Triangular Theory of Love," in *Advances in Consumer Research*, Vol. 15, Michael Houston, ed. Provo, UT: Association for Consumer, 163–68.
- Sirdeshmukh, Deepak, Jagdip Singh, and Barry Sabol (2002), "Consumer Trust, Value, and Loyalty in Relational Exchanges," *Journal of Marketing*, 66 (January), 15–30.
- Sirgy, M. Joseph, Dhruv Grewal, and Tamara Mangleburg (2000), "Retail Environment, Self-Congruity, and Retail Patronage: An Integrative Model and a Research Agenda," *Journal of Business Research*, 49 (2), 127–38.
- Spector, Robert and Patrick D. McCarthy (2005), *The Nordstrom Way to Customer Service Excellence: A Handbook for Implementing Great Service in Your Organization*. New York: John Wiley & Sons.
- Sternberg, Robert J. (1986), "A Triangular Theory of Love," *Psychological Review*, 93 (2), 119–35.
- (1987), "Liking Versus Loving: A Comparative Evaluation of Theories," *Psychological Bulletin*, 102 (3), 331–45.
- (1988), "Triangulating Love," in *The Psychology of Love*, R. Sternberg and M. Barnes, eds. New Haven, CT: Yale University Press, 119–38.
- Swan, John E. and Richard L. Oliver (1989), "Postpurchase Communications by Consumer," *Journal of Retailing*, 65 (Winter), 516–33.
- Thomson, Matthew, Deborah MacInnis, and C. Whan Park (2005), "The Ties That Bind: Measuring the Strength of Consumers' Emotional Attachments to Brands," *Journal of Consumer Psychology*, 15 (1), 77–91.
- Trinke, Shanna J. and Kim Bartholomew (1997), "Hierarchies of Attachment Relationships in Young Adulthood," *Journal of Social and Personal Relationships*, 14 (5), 603–625.
- Verhoef, Peter C. (2003), "Understanding the Effect of Customer Relationship Management Efforts on Customer Retention and Customer Share Development," *Journal of Marketing*, 67 (October), 30–45.
- , Philip H. Franses, and Jenny C. Hoekstra (2002), "The Effects of Relationship Constructs on Customer Referrals and Number of Services Purchased from a Multiservice Provider: Does Age of Relationship Matter?" *Journal of the Academy of Marketing Science*, 30 (3), 202–226.
- Westbrook, Robert A. and Richard L. Oliver (1991), "The Dimensionality of Consumption Emotion Patterns and Consumer Satisfaction," *Journal of Consumer Research*, 18 (1), 84–91.
- Whang, Y., J. Allen, N. Sahoury, and H. Zhang (2004), "Falling in Love with a Product: The Structure of a Romantic Consumer-Product Relationship," in *Advances in Consumer Research*, Vol. 31, Barbara E. Kahn and Mary F. Luce, eds. Valdosta, GA: Association for Consumer Research, 320–27.
- Yilmaz, C., B. Sezen, and O. Ozdemir (2005), "Joint and Interactive Effects of Trust and (Inter) Dependence on Relational Behaviors in Long-Term Channel Dyads," *Industrial Marketing Management*, 34 (3), 235–48.



Copyright of *Journal of Marketing Research* (JMR) is the property of American Marketing Association and its content may not be copied or emailed to multiple sites or posted to a listserv without the copyright holder's express written permission. However, users may print, download, or email articles for individual use.