

INVESTIGATION OF POWER QUALITY CATEGORISATION AND SIMULATING IT'S IMPACT ON SENSITIVE ELECTRONIC EQUIPMENT

Alok Thapar, *Student Member*, Tapan Kumar Saha, *Senior Member*, and Zhao Yang Dong, *Member, IEEE*

Abstract--With an increasing usage of sensitive electronic equipment power quality has become a major concern now. One critical aspect of power quality studies is the ability to perform automatic power quality data analysis and categorization. The objective of this paper is to present a technique based on fuzzy logic to categorize power quality events and to simulate the impact of power quality on sensitive equipment. Inherent features are extracted from recorded waveforms using Fourier and wavelet analyses and fed into a fuzzy expert system. The categorization technique has been implemented using the Fourier, Wavelet and Fuzzy Logic Toolboxes in MATLAB and tested with real power quality measured data. The impact of power quality on the operation of sensitive equipment has been illustrated through simulations in MATLAB SIMULINK. Such study is essential to predict the performance of modern loads and also to be able to explain why a specific load fails during a power quality event. The findings are reported in detail in this paper.

Index Terms— power quality, wavelet transform, Fourier transform, fuzzy logic, power quality categorisation, power quality impact on sensitive electronic equipment.

I. INTRODUCTION

Any variation in voltage, current, or frequency which may lead to an equipment failure or malfunction is potentially a Power Quality problem [1]. The classification and identification of power disturbances are governed by certain standards. The major cause of the problem is the increase in non-linear loads, which distort current and voltage waveforms. Modern electronic equipment is much more sensitive to such disturbances than traditional loads (lighting and motors) [2, 3]. The result is that the processes are interrupted, productivity is halted, and millions of dollars are lost.

A. Thapar, T.K. Saha and Z.Y. Dong are with the School of Information Technology and Electrical Engineering, University of Queensland, Australia (e-mails: alok@itee.uq.edu.au, saha@itee.uq.edu.au, zdong@itee.uq.edu.au).

To avoid this, the disturbances need to be first categorized so that relevant mitigation steps can be taken [4]. A technique based on fuzzy logic to categorize power quality events is described in this paper. Inherent features of disturbance voltage waveforms are extracted using Fourier and wavelet analyses and fed into a fuzzy expert system. An analysis of a variety of disturbance waveforms recorded at various commercial sites is also described in this paper. The impact of power quality on the operation of sensitive equipment has been illustrated through simulations in MATLAB SIMULINK. The findings from this study will help to predict the performance of modern loads and also to be able to explain why a specific load failed during a power quality event.

II. BACKGROUND INFORMATION

Voltage Variations are caused by fault conditions and the energisation of large loads, where high starting currents are involved. The faults can cause a 'drop', 'rise' and 'supply void' in the supply voltage, and are also known as sag, swell and interruptions respectively. Voltage sag is normally caused by system faults, energisation of heavy loads and starting of large motors. Swells are usually associated with system fault conditions, but they are not as common as voltage sags.

Waveform Distortion is defined as a steady-state deviation from an ideal sine wave of line frequency principally characterized by the spectral content of the deviation. Harmonics; notching and noise are the major waveform distortions [5].

Transients refer to part of the change in waveform that disappears during transition from one steady state operating condition to another; and they can be classified as either impulsive or oscillatory transients.

Among the various signal processing tools, Fourier and wavelet transforms are most popular for analyzing power quality events [6-8].

A signal can be represented in the frequency domain by its Fourier transform which is written as in (1)

$$F[k] = \frac{1}{N} \sum_{n=0}^{N-1} f[n] e^{-j(2\pi kn/N)}, k=0, 1, \dots, N-1 \quad (1)$$

where $f[n]$ is the discrete-time signal, $F[k]$ is its frequency domain representation [6].

Wavelet decomposition provides a way of analyzing a signal both in time and frequency domains. If we denote f as a function defined on the whole real line, then, for a suitably chosen mother wavelet function ψ , f can be expanded as in (2)

$$f(t) = \sum_{j=-\infty}^{\infty} \sum_{k=-\infty}^{\infty} w_{jk} 2^{j/2} \psi(2^j t - k) \quad (2)$$

Where the functions $\psi(2^j t - k)$ are all orthogonal to each other. The coefficient w_{jk} gives information about the behaviour of the function f concentrating on the effects of scale around 2^{-j} near time $t \times 2^{-j}$. This wavelet decomposition of a function is closely related to a similar decomposition (the discrete wavelet transform, DWT) of a signal observed in discrete time [7, 8].

Frequency based analysis is very common, but it is not ideally suitable for transient analysis as time information is lost. For non-stationary signals wavelet analysis allows the use of long time intervals where we want more precise low-frequency information, and shorter regions where we want high-frequency information [7, 9, 10]. This is evident from Fig. 1.

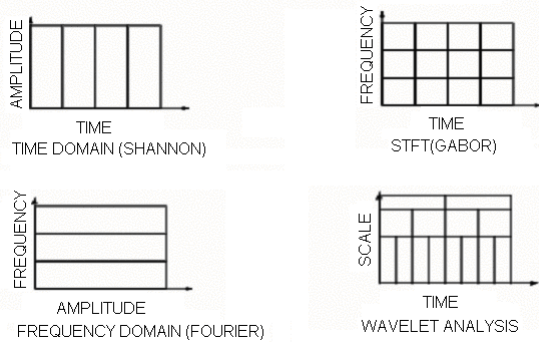

Fig. 1. Signal Analysis Techniques

Wavelet transform adapts more to dynamic signals and is appropriate for capturing time-localized short period phenomena while Fourier transform is suitable for analyzing stationary signals and extracting spectrum components at specific frequencies [11]. Our recorded samples of disturbances range from very slow to very fast changing disturbances.

Various approaches for feature extraction have been proposed for classifying the power quality events. A comparatively recent research compares the energies of different wavelet transform levels of a simulated disturbance waveform with that of a pure sinusoidal waveform. The comparisons result in very easily recognizable patterns for different disturbance signals [12]. This method may experience difficulties in dealing with a wide range of real life recorded power disturbances. A combination of Fourier transform and wavelet transform works in a more efficient manner for feature extraction than either of these two alone.

Past researches have proven fuzzy logic (FL) as a powerful categorization tool [6, 13, 14]. Fuzzy logic has two different meanings. In a narrow sense, fuzzy logic is a logical system, which is an extension of multi-valued logic. But in a wider sense, which is in predominant use today, fuzzy logic is almost synonymous with the theory of fuzzy sets, a theory which relates to classes of objects with unsharp boundaries in which membership is a matter of degree [9, 15].

III. DETECTION AND CATEGORIZATION OF POWER QUALITY EVENTS USING FUZZY LOGIC

A. Feature extraction

The following features inherent to different types of power quality events have been extracted using the corresponding formulas [6]:

1. Fundamental component. It will be large for Swells and small for Sags and Outages.

$$V_n = 2 * abs(V^n [1])$$

2. Phase Angle Shift.

$$PS_n = angle(V^n[1]) - angle(V[1])$$

3. Total Harmonic Distortion. It will be large for Harmonic disturbances.

$$THD_n = \sqrt{\sum_{k=2}^{\text{int}(N/2)} \{abs(V^n[k])\}^2 / V^1[1]}$$

4. Number of peaks of the Wavelet Coefficient. It will be large for Notches.

$$N_n = \text{peak}(abs(WC^n[k])), \text{ for all } k.$$

5. Energy of the Wavelet Coefficients. It will be large for Transients.

$$EW_n = \sum_{k=1}^{\text{leng}} abs(WC^n[k])$$

6. Oscillation number of Missing Voltage. It will be large for Transients.

$$OS_n = \text{root}(v^s_{miss}) \text{ where}$$

$$v_{miss}[i] = v[i] - (2/N) * abs(V^n[1]) * \cos\{angle(V^n[1]) + 2\pi(i-1)/N\}$$

and v^s_{miss} is an array of $v_{miss}[i]$, $i = 0, 1, 2, \dots, L-1$.

7. Lower Harmonic Distortion. It will be large for Harmonic disturbances.

$$TS_n = \sqrt{\sum_{k=2}^{10} \{abs(V^n[k])\}^2 / V^1[1]}$$

8. Oscillation Number of RMS Variations, e.g. it will be large for Flickers.

$$RN = root(V_{rms}^s - mean(V_{rms}^s))$$

where V_{rms}^s is an array of V_{rms}^n which is defined as

$$V_{rms}^n = \sqrt{\frac{1}{N} \sum_{i=0}^{N-1} v^2[i + (n-1)N]}$$

- $V^n[k]$ is the Discrete Fourier Transform (DFT) for the samples contained in the n th data window and $V[k]$ is the DFT for the whole signal.
- WC^s is an array of $WC_n[k]$ for $k = 1, 2 \dots leng$ where $leng$ is the length of $WC_n[k]$.
- n is the number of data windows.
- $v[i]$ represents the sampled input signal, $i = 0, 1, 2, 3, \dots, L-1$ where L is the length of the signal.
- N is the number of samples in one data window (one cycle).
- WC are the second level detail wavelet coefficients obtained by using Daubechies-4 wavelet.
- $abs(\cdot)$ gives the absolute value of the argument.
- $angle(\cdot)$ returns the phase angle of the input argument.
- $int(N/2)$ equals $N/2$ if N is even, and $(N-1)/2$ if N is odd.
- $peak(\cdot)$ returns the number of peaks of the argument.
- $root(\cdot)$ returns the number roots (zero-crossings) of the argument
- $mean(\cdot)$ returns the mean of the argument.

B. Categorization

A brief rule set for the fuzzy expert system is as follows:

- Rule 1: if V_n is A_4 and N_n is F_1 and OS_n is G_1 then IMPULSE.
- Rule 2: if V_{n+1} is A_5 and $\{PS_n$ is C_1 or PS_{n+1} is $C_1\}$ then SWELL.
- Rule 3: if V_{n+1} is A_2 or V_{n+1} is A_3 and $\{PS_n$ is C_2 or PS_{n+1} is $C_2\}$ then SAG.
- Rule 4: if V_{n+1} is A_3 and N_n is F_2 and OS_n is G_2 then NOTCH.
- Rule 5: if RN is K_1 then FLICKER.
- Rule 6: if THD_n is B_2 and THD_{n+1} is B_2 and THD_{n+2} is B_2 then HARMONIC.
- Rule 7: if V_n is A_1 or V_{n+1} is A_1 then OUTAGE.
- Rule 8: if V_n is A_6 and V_{n+1} is A_6 then SWELL
- Rule 9: if OS_{n+1} is G_2 and THD_n is B_2 and EW_n is D_1 then TRANSIENT.
- Rule 10: if $root(v^s) > (2 * \text{no. of cycles recorded})$ then PROBLEM FOR SWITCHING DEVICES.

IMPULSE, SWELL, SAG, NOTCH, FLICKER, HARMONIC, OUTAGE, and TRANSIENT are fuzzy variables which represent the degree (membership) to which a particular power quality event belongs to these categories. A higher membership value implies that a particular disturbance is more dominant in the test waveform. $A_i, B_i, C_i, D_i, F_i, G_i, H_i,$ and K_i are the membership functions for the inputs which are obtained from the eight extracted features. Triangular and trapezoidal membership functions are used.

IV. CASE STUDIES AND RESULTS

Various locations in and around Brisbane were monitored for disturbances in voltage waveforms. The equipment used was the BMI 8010 PQNode, developed by Basic Measuring Instruments (BMI) of California in conjunction with Electrotek Concepts Inc[16]. The BMI 8010 PQNode can be set to stand-alone operation at the selected site to perform power quality monitoring. Communication between the PQNode and a computer is via a RS-232 link. Following is a case study based on the power quality data recorded by the BMI 8010 PQNode [17].

Voltage waveforms which were recorded are given in Fig. 2-6. These are only a few of the waveforms which were used to build the proposed system. The events and their respective membership values corresponding to Fig. 2-6 are given in Table I.

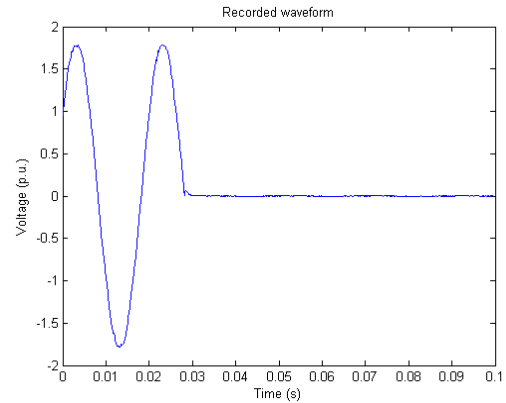

Fig. 2. Recorded waveform- 1

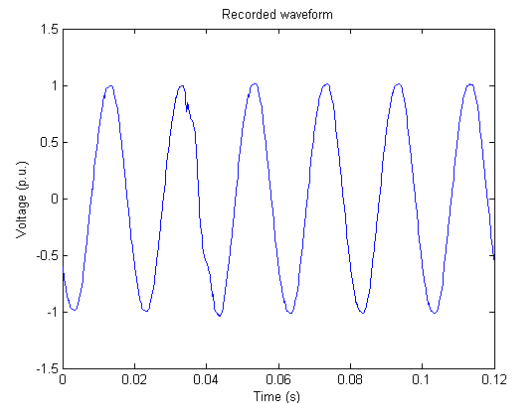

Fig. 3 Recorded waveform- 2

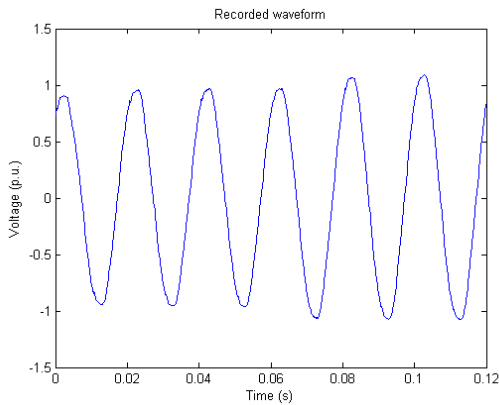

Fig. 4 Recorded waveform- 3

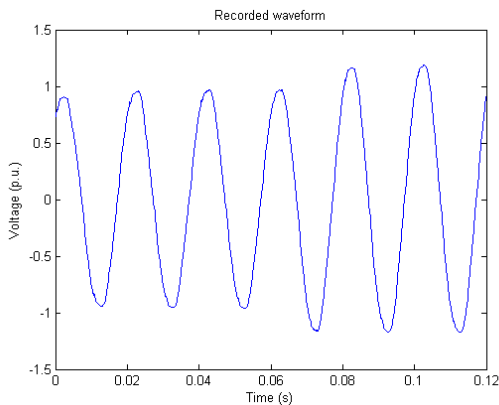

Fig. 5 Recorded waveform- 4

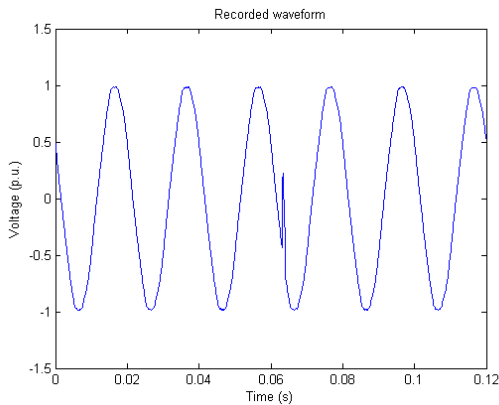

Fig. 6 Recorded waveform-5

TABLE I
ANALYSIS RESULTS

EVENTS	Fig2	Fig3	Fig4	Fig5	Fig6
IMPULSE	0	0	0	0	1
SWELL	1	0	0.15	1	0
SAG	0	0	0.05	0	0.07
NOTCH	0	1	0	0	0
FLICKER	0	0	0	0	0
HARMONIC	0	0	0	0	0
OUTAGE	1	0	0	0	0
TRANSIENT	1	1	0.05	1	1

A typical example of a membership greater than zero but less than one is Fig. 4. It is evident from the membership values for SWELL, SAG and TRANSIENT that there is a disturbance in the waveform of small magnitude but it cannot be neglected because our rule set has been designed such that it detects every possible disturbance. In this case SWELL, which has the maximum value of membership, is the disturbance present in this waveform. In a similar way results have been obtained for various recorded waveforms.

V. SIMULATION OF IMPACT ON SENSITIVE ELECTRONIC EQUIPMENT

This paper also investigates the impact of power quality on sensitive devices. At this stage, the focus is on the operation characteristics of a Vector Controlled Variable Frequency Induction Motor Drive (as shown in Fig. 7) in the presence of sag events.

The motor under consideration is a 50 HP, 460V and 60 Hz asynchronous machine. A DC voltage of 780V average is obtained at the DC link from the diode bridge rectifier which takes a nominal 3-phase (star-connected) input of 580V rms. line-to-line.

Voltage sags are normally described by magnitude variation and duration. In addition to these quantities, sags are also characterized by unbalance, non-sinusoidal wave shapes, and phase angle shifts.

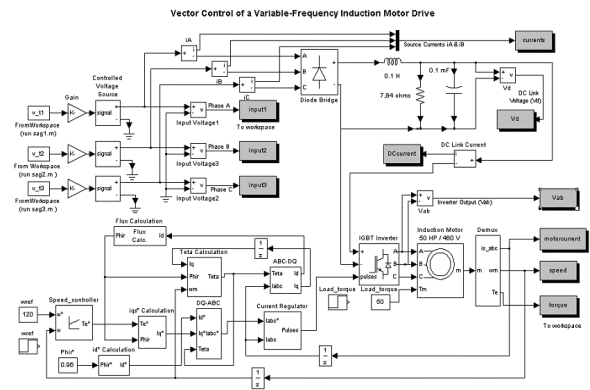

Fig. 7 Vector controlled Variable Frequency Induction Motor Drive

Table II shows three cases of inputs “A” to “C” supplied as unbalanced sags to the above system, and the corresponding outputs observed.

Fig. 8-10 illustrate disturbance inputs, the fall in DC link voltage and change in rotor speed for Case C corresponding to the sag event that occurs at time t= 3 seconds when Phase A and Phase B experience a line-to-ground fault. The fall in DC link voltage, and the rotor speed are observed for the period of the event. When normal supply resumes, the DC link voltage stabilises at 780 Volts and the rotor speed at 120 radians per second.

**TABLE II
SIMULATION RESULTS**

INPUTS CASE			
	A	B	C
Sag magnitude : Phase A (p.u.)	1	0.1	1
Phase B	0.5	1	0.1
Phase C	0.5	1	0.1
Start time of sag (sec)	3	3	3
Duration of sag (sec)	1	1	1
Phase angle shift: Phase A (radians)	0	0	0
Phase B	-1.047	0	0
Phase C	1.047	0	0
Load torque (N-m)	50	50	50
Start time of load (sec)	0	0	0
Duration of load (sec)	4	4	4
Reference rotor speed (rad/s)	120	120	120
OBSERVATIONS			
Nominal DC link Voltage (V)	780	780	780
DC link Voltage during event (V)	450	570	350
Change in DC link Voltage (%)	42.3	26.9	55.12
Rotor speed during event (rad/s)	120	120	112.8
Change in rotor speed (%)	0	0	6

Source currents are positive as well as negative as they are coming from an AC source but since they pass through diodes they appear as square waveform.

The variable response of the motor drive to the various inputs is evident from the above experimental results. No significant changes were observed for sag inputs with phase shift [18]. Phase angle jump has no effect unless the power electronics in the system use the phase angle information to determine firing instants. Our system did not have such a configuration. For unbalanced sag inputs, an unbalance in source/line currents was observed as shown in Fig. 11.

Also, the ability of the drive to ride-through a voltage sag event is dependent upon the energy storage capacity of the DC link capacitor, the speed and inertia of the load, the power consumed by the load, and the trip point settings of the drive. The control system of the drive has a great impact on the behaviour of the drive during sag and after recovery. The trip point settings can be adjusted to greatly improve many nuisance trips resulting from minor sags which may not affect the speed of the motor.

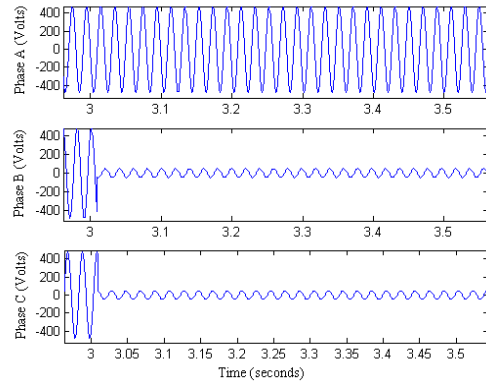

Fig. 8 Unbalanced Sag Input

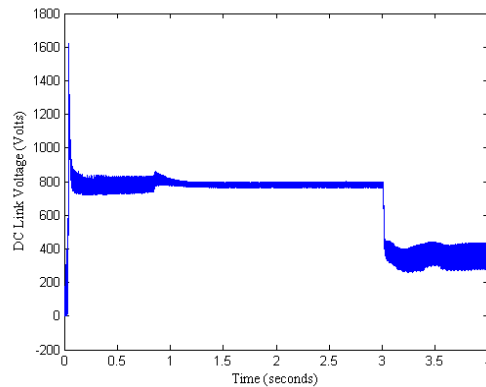

Fig. 9 DC Link Voltage

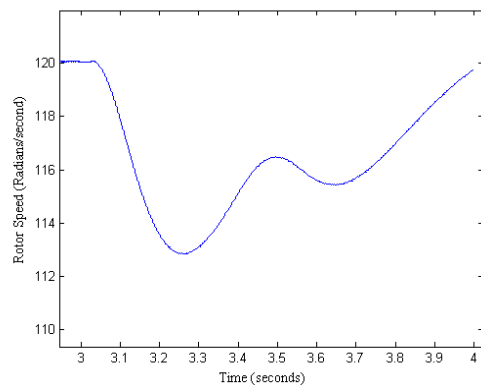

Fig. 10 Rotor Speed

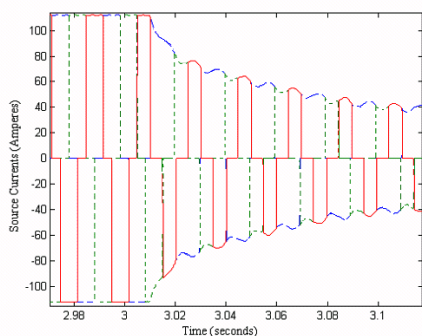

Fig. 11 Unbalanced source currents

VI. CONCLUSIONS

This paper presents a practically efficient tool for power quality data analysis and categorization as well as some initial findings of power quality impact on sensitive equipment. The categorization method uses Fourier transform, wavelet techniques and fuzzy set rules to identify power quality problems with minimal errors. The proposed method has been implemented for analysis and categorization of power quality data collected from various sites in Brisbane, Australia. Results are given to illustrate the effectiveness and robustness of the proposed method in power quality categorization applications. Behaviour of a Vector controlled Variable Frequency Induction Motor Drive in the presence of sag events has been simulated as our initial investigation of impact of power quality on sensitive equipment. More work is currently in progress to validate the proposed tool, which will be reported in near future.

VII. REFERENCES

- [1] R. C. Dugan, M. F. McGranaghan, and H. W. Beaty, *Electrical power systems quality*. New York: McGraw Hill, 1996.
- [2] M. H. J. Bollen, IEEE Industry Applications Society, IEEE Power Electronics Society, and IEEE Power Engineering Society, *Understanding power quality problems : voltage sags and interruptions*. New York: IEEE Press, 2000.
- [3] W. W. Dabbs, D. D. Sabin, T. E. Grebe, and H. Mehta, "Probing power quality data," *IEEE Computer Applications in Power*, vol. 7, pp. 8-14, 1994.
- [4] P. F. Ribeiro and D. A. Rogers, "Power electronics, power quality and modern analytical tools: the impact on electrical engineering education," in *Proceedings. Frontiers in Education. Twenty Fourth Annual Conference*, L. P. Grayson, Ed., 1994, pp. 448-51.
- [5] L. W. Cheok, T. K. Saha, and Z. Y. Dong, "Power quality investigation with wavelet techniques," presented at AUPEC 2002, Melbourne, Australia, 2002.
- [6] M. Kezunovic and Y. Liao, "A novel software implementation concept for power quality study," *IEEE Transactions on Power Delivery*, vol. 17, pp. 544-9, 2002.
- [7] Y. F. Low and Z. Y. Dong, "Enhancing Neural Network Electricity Load Forecast with Wavelet Techniques," presented at ASCC 2001, Singapore, 2001.
- [8] B. N. Tran, T. M. Nguyen, and M. M. Shihabi, "Wavelets," J. Websters Wiley Encyclopaedia of

Electrical and Electronics Engineering ed: John Wiley & Sons Inc., 1999.

- [9] "Matlab Help files," Matlab 6.0.
- [10] A. Al Rawi and M. Devaney, "Wavelets and power system transient analysis," in *IEEE Instrumentation and Measurement Technology Conference.*: IEEE, New York, NY, USA, 1998, pp. 1331-1334 vol 2.
- [11] I. Daubechies, "The wavelet transform, time-frequency localization and signal analysis," *IEEE Transactions on Information Theory*, vol. 36, pp. 961-1005, 1990.
- [12] J. W. Resende, M. L. R. Chaves, and C. Penna, "Identification of Power quality disturbances using MATLAB wavelet transform toolbox," 2001, 2001.
- [13] S. Santoso, E. J. Powers, W. M. Grady, and A. C. Parsons, "Power quality disturbance waveform recognition using wavelet-based neural classifier. I. Theoretical foundation," *IEEE Transactions on Power Delivery*, vol. 15, pp. 222-8, 2000.
- [14] W. R. Anis Ibrahim and M. M. Morcos, "Artificial intelligence and advanced mathematical tools for power quality applications: a survey," *IEEE Transactions on Power Delivery*, vol. 17, pp. 668-73, 2002.
- [15] J. Yen and R. Langari, *Fuzzy logic : intelligence, control, and information*. Upper Saddle River, N.J.: Prentice Hall, 1999.
- [16] E. C. Inc., "Electrical Power Systems Quality," <http://www.electrotek.com>, 1994.
- [17] B. M. Instruments(BMI), *PQ Node User's Manual*, 2 ed: Basic Measuring Instruments, 1993.
- [18] E. R. Collins, Jr. and A. Mansoor, "Effects of voltage sags on AC motor drives," in *1997 IEEE Annual Textile, Fiber and Film Industry Technical Conference Cat. No.97CH36100*. 1997: IEEE, New York, NY, USA, 1997, pp. 9. 7 p.

VIII. BIOGRAPHIES

Alok Thapar (S 2002) received the B.Tech. Degree in electrical engineering from the Indian Institute of Technology, Kanpur, India in 2002. He is currently pursuing Masters Degree in Electrical Engineering at The University of Queensland, Australia.

Tapan Kumar Saha (SM 1997) was born in Bangladesh and came to Australia in 1989. Dr. Saha is currently an Associate Professor in the School of Information Technology and Electrical Engineering, University of Queensland, Australia. Before joining The University of Queensland in 1996, he taught at the Bangladesh University of Engineering and Technology, Dhaka, Bangladesh for three and half years and then at James Cook University, Townsville, Australia for two and half years. He is a Fellow of the Institution of Engineers, Australia. His research interests include power systems, power quality and condition monitoring of electrical plants.

Zhao Yang Dong (S 1995, M 1998) obtained his PhD from Sydney University, Australia in 1999. Now he is a Senior Lecturer in the School of Information Technology and Electrical Engineering, University of Queensland, Australia. His research interests include electricity market, power system security assessment, artificial intelligence and its application to power engineering.