

105
6-10-80
JWP

LA-8322-MS

Informal Report

DR. 1290

[Handwritten signature]

**Investigation of Pressure Transients in
Nuclear Filtration Systems
Construction Details of a Large Shock Tube**

University of California



LOS ALAMOS SCIENTIFIC LABORATORY

Post Office Box 1663 Los Alamos, New Mexico 87545

INVESTIGATION OF PRESSURE TRANSIENTS IN NUCLEAR FILTRATION SYSTEMS

Construction Details of a Large Shock Tube

by

P. R. Smith and W. S. Gregory

ABSTRACT

This report documents the construction of a 0.914-m (36-in.)-diam shock tube. The shock tube is located on the New Mexico State University campus and is operated by the Mechanical Engineering Department for the Los Alamos Scientific Laboratory. Highly variable low-grade explosions can be simulated with the shock tube. We plan to investigate the response of nuclear facility ventilation system components to low-grade explosions. Components of particular interest are high-capacity, high efficiency particulate air (HEPA) filters. Shock tube construction details, operating principles, firing sequence, and preliminary results are reported.

I. INTRODUCTION

This program at the Los Alamos Scientific Laboratory (LASL) has been initiated because of interest in assuring the safety of nuclear facility airborne waste management systems. Response of airborne waste systems to hypothetical pressure surges from tornadoes or explosions is of particular concern, and special experimental devices have been constructed to generate variable pressure pulses. Other reports describe a device that can simulate tornado pressure pulses.^{1,2} In this report we will describe the construction and operating details of a device capable of simulating low-grade explosive pressure pulses.

Pressure surges associated with low-grade explosions develop extremely fast in contrast to those that could be induced by tornadoes. Explosively driven

pressure surges are transmitted in the form of shock waves that can range from 1 to 50 ms in duration. The peak pressure of these shock waves is highly variable. At locations close to the explosive event, the peak pressure may be relatively high compared to that at locations that are far away. Thus the total impulse behind an explosive wave can be quite variable. However, we believe that the variability of these waves can be closely matched by the shock waves generated in a shock tube. The conceptual design and small scale testing of such a shock tube has been described in earlier reports.^{3,4}

II. GENERAL DESCRIPTION

Figure 1 is a drawing that shows the construction details of the 0.914-m (36-in.)-diam shock tube that is located on the New Mexico State University campus in Las Cruces, New Mexico. The total length of the shock tube is 48.77 m (160 ft). The tube consists of three sections, all made of 0.91-m (3-ft)-i.d. steel pipe, namely: 1) a driver or high-pressure section 11.76 m (38.58 ft) long, 2) an interstage or double diaphragm section 0.43 m (17 in.) long, and 3) a driven or low-pressure section 36.58 m (120 ft) long. These sections appear from left to right, respectively, in Fig. 1.

The driver section can be pressurized to a maximum of about 2415 kPa (350 psig) by a large diesel-driven compressor. Therefore peak pressure differences across the generated shock wave will be approximately 345 kPa (50 psi). The dwell time of the high-pressure pulse is adjusted by varying the length of the driver (high-pressure) section by the use of a movable wall. Dwell time of the pressure rise behind the shock wave can be varied from a few milliseconds to approximately 50 ms. Figure 2 is a reduced blueprint of this scheme. With both peak pressure and dwell time selectable, the total impulse may be varied over a wide range. The movable wall is sealed by a pneumatically expanded rubber tube around its rim. A system of movable steel carts (load-carrying spacers) transfers the large axial forces, which may be as high as 1583×10^3 N (356 000 lb) to the rear support flange, and puts the pipe in tension. The carts are shown in Fig. 2 bearing against four 0.06-m (2-1/2-in.)-diam adjustment screws that allow the volume of the high-pressure section to be precisely controlled.

FOUNDATION

- R₁
- R₂, R₄
- R₃, R₅, R₆
- R₇, R₈

DESCRIPTION

- PIPE RIGIDLY FIXED TO CONCRETE PIER
- PIPE SITTING ON GRINNELL PIPE ROLL STAND
- PIPE SITTING ON GRINNELL PIPE ROLL STAND W/TIE DOWN STRAP
- PIPE SITTING ON ROUNDWAY BEARING ASSEMBLY

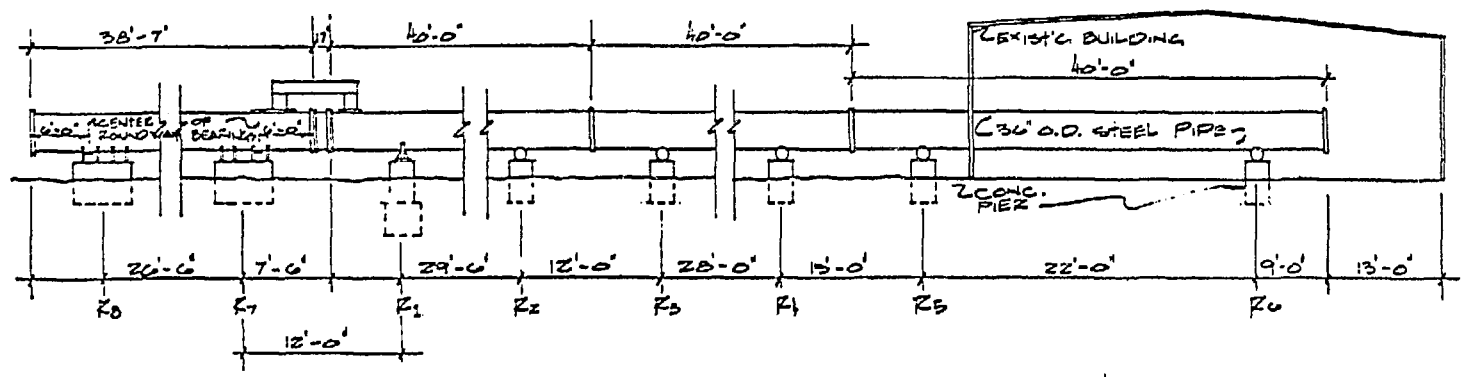

MECHANICAL ENGR. DEPARTMENT NEW MEXICO STATE UNIVERSITY LAS CRUCES NEW MEXICO		
FOUNDATION FOR PROPOSED SHOCK TUBE		
PC/1 GE G	DT:8/6/78	DRAWN BY Z. MARQUA

Fig. 1.
Reduced copy of construction blueprint of the overall shock tube.

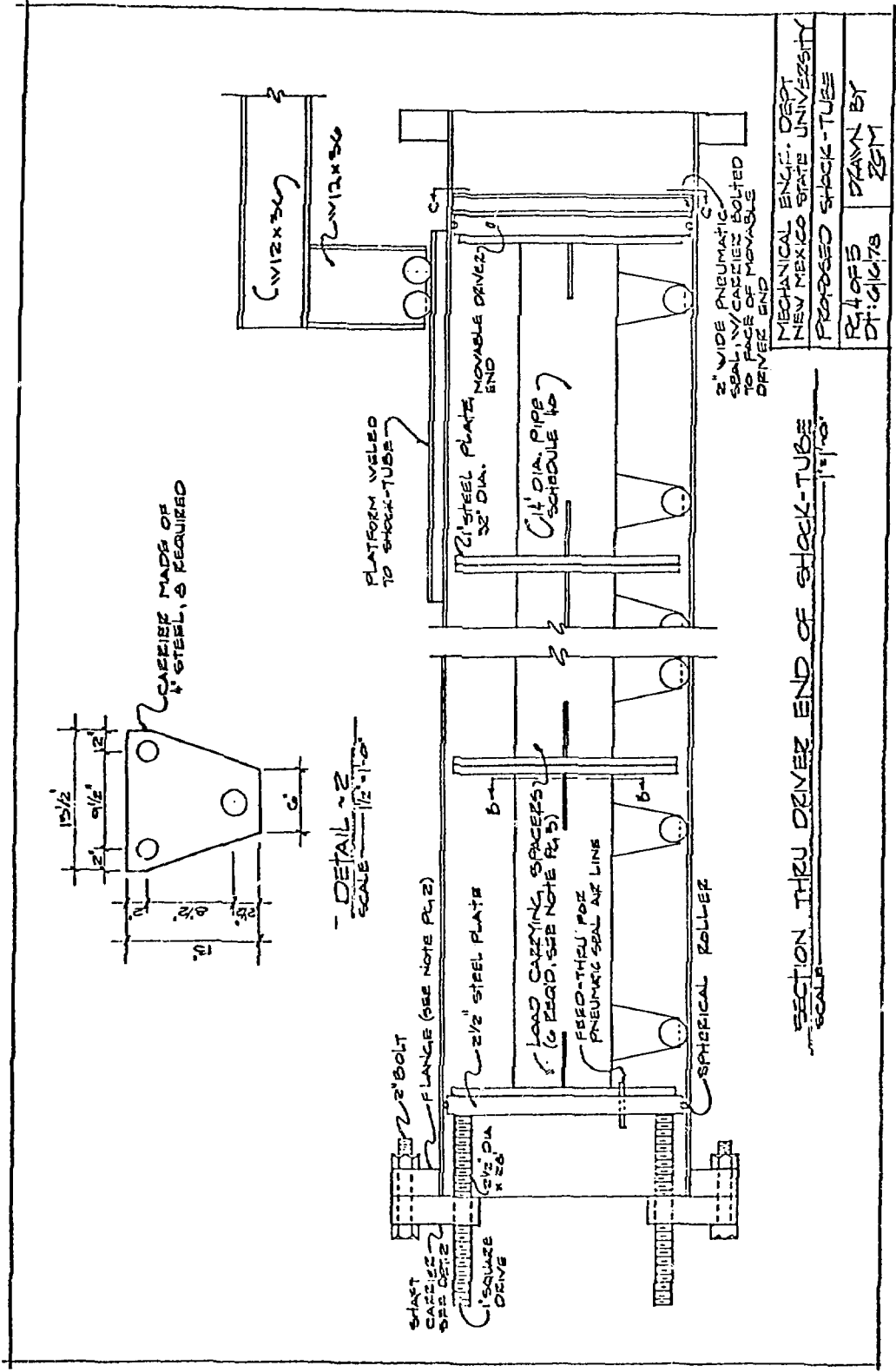

Fig. 2. Scheme for a movable end wall in the driver section.

III. DOUBLE DIAPHRAGM OPERATION

To generate a simulated explosive wave, the shock tube is fired by rupturing metal diaphragms separating the driver (high-pressure) section from the driven (low-pressure) section. A drawing of the double diaphragm system used is presented in Fig. 3. A short 0.43-m (17-in.)-length of 0.91-m (3-ft)-diam tubing is placed between the driver section and the driven section. A thin metal diaphragm of a diameter equal to the flange diameters is placed on each end of the interstage (double diaphragm) section. Both the interstage and the driver sections are movable. After the diaphragms are in place, a pneumatic piston slides the driver forward until it clamps the interstage against the driven section. Final pressure sealing is obtained by bolting the flanges of the sections together with 0.05-m (2-in.)-diam bolts.

The firing sequence has three stages. 1) Pressurize the interstage region between the diaphragms to one-half the desired driver pressure. The diaphragm material has been selected so that it will not break at this intermediate differential pressure. 2) Pressurize the driver section to the desired value. (If a diaphragm were subjected to this full pressure, it would break.) 3) A 0.05-m (2-in.) solenoid valve is actuated, exhausting the interstage section to the atmosphere. The sudden drop in pressure in the interstage region causes the diaphragm between the driver and the interstage section to rupture. The subsequent large impulse of air against the second diaphragm causes it to rupture sharply, and a shock wave then forms in the driven section and proceeds down the tube to the test section. The advantages of this firing method are that no mechanical devices are needed inside the tube to initiate firing. Repeatability of initial pressures is assured for subsequent tests because premature rupture of diaphragms is eliminated.

IV. CONSTRUCTION STAGES

Figures 4--7 are photographs showing various stages of the shock tube construction. Three of the concrete piers that support the tube are pictured in Fig. 4. The four anchor bolts in the pier in the foreground are 0.05 m (2 in.) in diameter. Figure 5 shows the final 12.19-m (40-ft) length of the driven section being lowered into position on its two concrete piers. Notice that the right pier has a large roller on which the pipe will rest. The left pier has

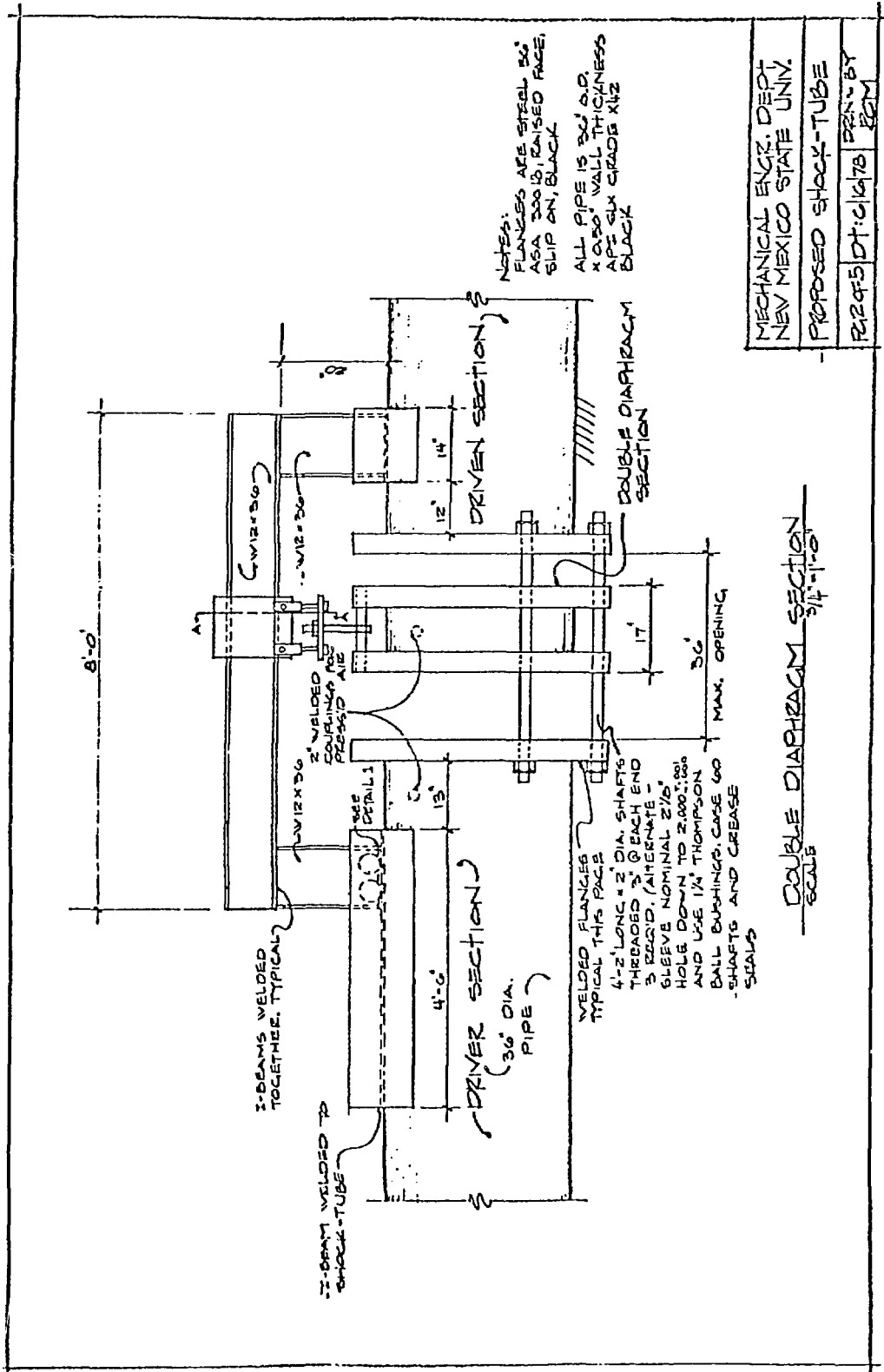

Fig. 3.
Double diaphragm (interstage) section details.

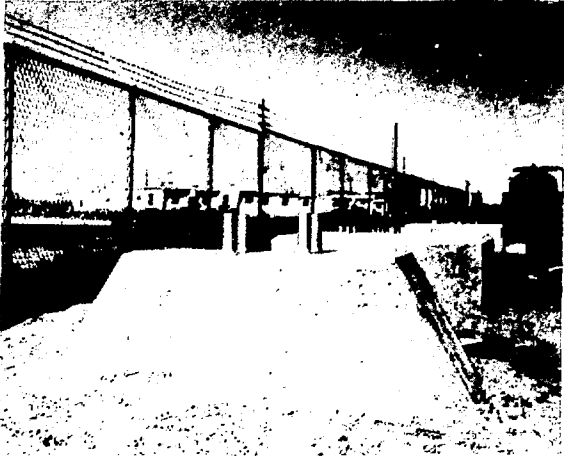

Fig. 4.
Photograph of concrete piers that support the shock tube.

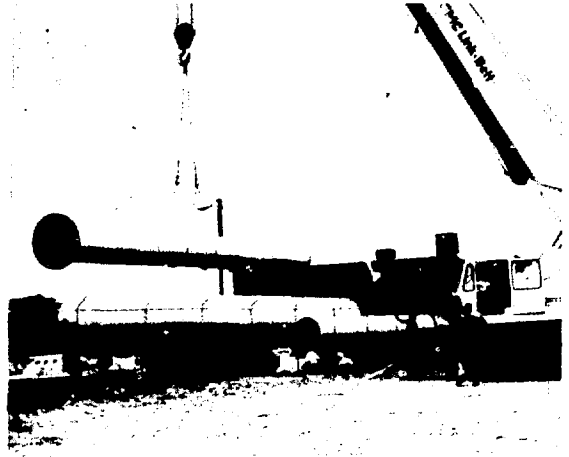

Fig. 5.
Last length of driven section being lowered into position.

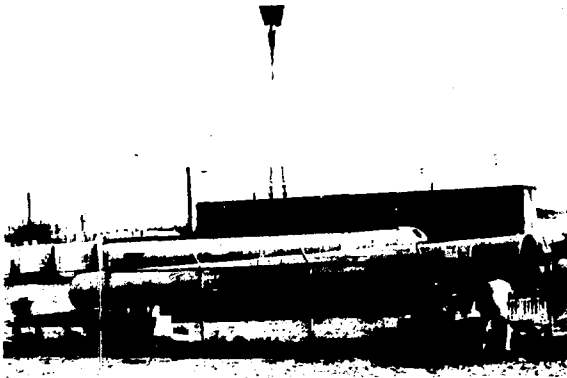

Fig. 6.
The driver section of the shock tube being lowered into its support cradles.

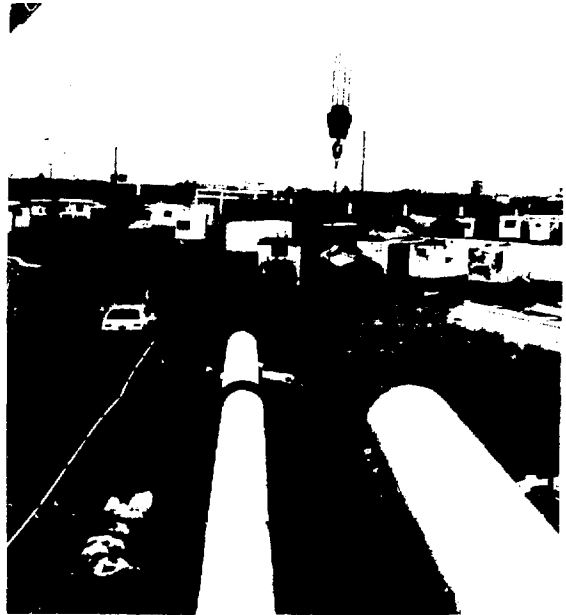

Fig. 7.
Driver flanges being lifted into place.

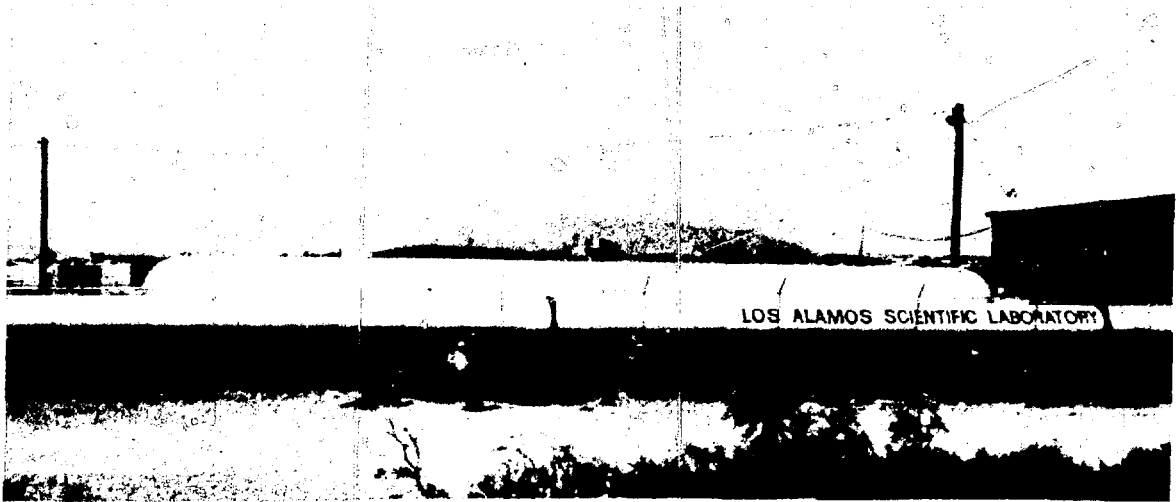

Fig. 8.
Wide-angle view of the completed shock tube.

a steel cradle mounted on it. The pipe was welded to this cradle to hold it in place. The other lengths of the driven section were mounted on rollers so that thermal expansion could be accommodated.

The driver section is shown in the photograph in Fig. 6 as it is being lowered into its cradles. These cradles were fitted with roundway bearings so that the driver can be moved along its axial direction for a distance of approximately 0.91 m (3 ft).

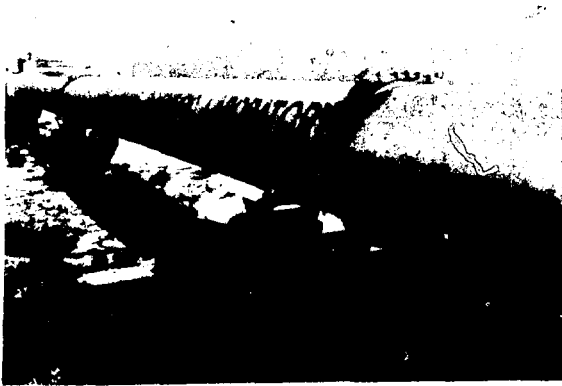

Fig. 9.
View of completed shock tube looking from the driven section toward the driver section.

A view from the top of the test building (Fig. 7) shows the flanges for the driver section being lifted into place. Once in place and aligned, the flanges were welded to the pipe by a certified welder.

The completed shock tube is shown in a wide angle view in Fig. 8. Figure 9 shows the completed shock tube viewed from the test building. In the foreground are the three lengths of pipe making up the driven section. They are held together by Victaulic couplings. These couplings



Fig. 10.
View from the driver end of the shock tube.

were chosen because they are able to compensate for small misalignments and are quick and easy to install. Inspection of the interior pipe joints at these couplings revealed no more than a 0.079-mm (1/32-in.) mismatch at any joint. Also visible in this photograph are the steel rollers supporting the driven section. In the background are the two high-pressure air supply tanks of the test facility.

A view of the completed shock tube from the driver section toward the test building is shown in Fig. 10. In the foreground the end of a movable load transfer cart is visible within the driver section. This cart will bear against four large 0.06-m (2-1/2-in.)-diam adjustment screws when a high pressure is introduced into the driver section. The small hose entering the end of the shock tube supplies high-pressure air to the pneumatic seal of the movable end wall (not visible). At the other end of the driver section, the solenoid valve (black cylindrical object) that exhausts the interstage region for firing the shock tube can be seen.

The interstage section can be seen in the right foreground in Fig. 11. The I-beam system on top of the shock tube supports the interstage when the driver

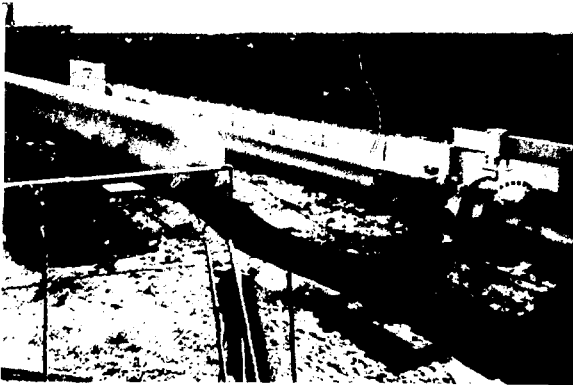

Fig. 11.
Photograph of shock tube with the double diaphragm (interstage) section in the right foreground.

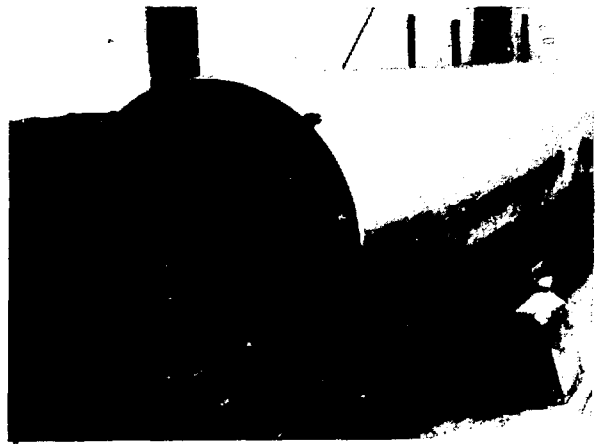

Fig. 12.
Test section of the shock tube with a 0.609- by 0.609-m (24- by 24-in.) HEPA filter in place.

section is moved back to the right. The driver section is moved by the pneumatic cylinder (thin cylinder with the long push rod) visible beneath the interstage section.

The test section of the shock tube is within the test building. Figure 12 shows the test section with a high efficiency particulate air (HEPA) filter in place ready for testing. Not shown is a section of steel culvert that slips over the end of the shock tube and is sealed by a banded rubber collar. This culvert extends through an overhead door to the exterior of the building so that the shock wave is dissipated outside of the building.

V. PRELIMINARY OPERATING RESULTS

The shock tube has been successfully operated several times. Shock overpressures achieved were within 5% of overpressures predicted by theory. Dwell time of the high-pressure region behind the shock was also within 5% of the predicted value. Figure 13 is a polaroid photograph of a pressure pulse obtained in an initial test. Pressure is the vertical scale, and time is the horizontal scale. The pressure scale is 20.7 kPa (3 psi) per division, and the time scale is 20 ms per division. The driver pressure for this test was 85.6 kPa (12.4 psig), and ambient pressure was 86.9 kPa (12.6 psia). When the shock

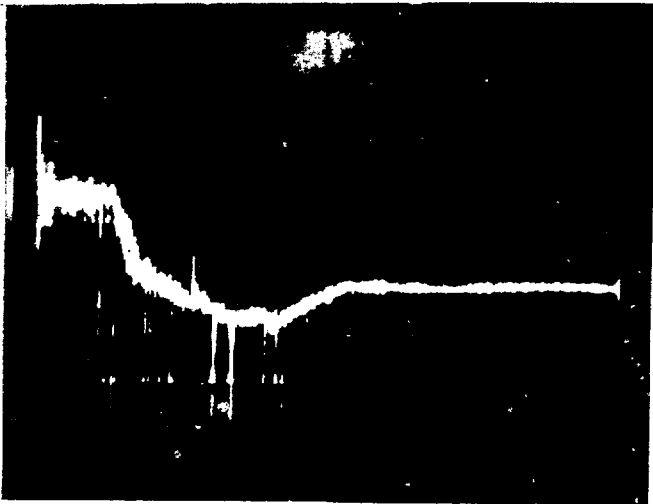

Fig. 13.

Pressure signature of an initial shock wave in the 0.91-m (3-ft)-diam shock tube. Driver pressure was 85.6 kPa (12.4 psia).

reached the electronic pressure transducer (shown mounted on the side of the pipe in Fig. 12), the pressure jumped up to the level indicated at the far left of the picture and remained constant for approximately 25 ms. Then an expansion wave passed the pressure transducer, and the pressure was seen to drop below ambient for approximately the next 50 ms. Finally, it rose again slightly in about 30 ms and stabilized at the ambient pressure, that is, the level at the right side of the picture. Hence, the shock tube is

operating as it should, and preliminary testing of HEPA filters can now begin.

VI. SUMMARY

We have presented an overview of the steps involved in constructing a shock tube that will be used to simulate low-grade explosions. The response of ventilation components will be investigated, particularly high-capacity V-type HEPA filters. The operation of the shock tube with its movable endwall is described. This feature allows us to achieve control over the shock wave duration, and together with adjustable peak pressure, allows control of the total impulse imposed on the test specimen. Also described is the double diaphragm system used to initiate the shock transient. Preliminary firings are reported and a recorded shock wave pulse is shown. We are now ready to begin testing standard HEPA filters to determine their structural limits under shock loading.

REFERENCES

1. W. S. Gregory, P. R. Smith, C. I. Ricketts, and G. Reynolds, "Pressure Transients Across HEPA Filters," Proceedings of Seminar on High Efficiency Aerosol Filtration, Aix-en-Provence, France (November 1976).

2. W. S. Gregory, H. L. Horak, P. R. Smith, and C. I. Ricketts, "Investigation of HEPA Filters Subjected to Tornado Pressure Pulses," Los Alamos Scientific Laboratory report LA-NUREG-6762-PR (March 1977).
3. W. S. Gregory and P. R. Smith, "Ventilation System Pressure Transients - Proposed Experiments and Shock Tube Conceptual Design," Los Alamos Scientific Laboratory report LA-7413-MS (September 1978).
4. D. LaPlante, P. R. Smith, and W. S. Gregory, "Ventilation System Pressure Transients - Small Scale Shock Tube Results," Los Alamos Scientific Laboratory report LA-7726-MS (April 1979).