

V. Kumar<sup>1</sup>,  
C. Prakash<sup>2,\*</sup>,  
G. Manigandan<sup>1</sup>,  
V.R. Sampath<sup>3</sup>

# Investigation of the Influence of Stretch on the Air Permeability of Knitted Fabric: Effect of Loop Length

DOI: 10.5604/01.3001.0014.5045

<sup>1</sup>Shahi Exports Pvt Ltd, Arekere Village,  
Bannerghatta Main Road, Bangalore 560076,  
Karnataka, India

<sup>2</sup>Indian Institute of Handloom Technology,  
Department of Handloom and Textile Technology,  
Fulia Colony, Nadia 741402, West Bengal, India,  
\* e-mail: dearcprakash@gmail.com

<sup>3</sup>Bahir Dar University,  
Ethiopia Institute of Textile and Fashion,  
Department of Textile Technology,  
Bahir Dar, Ethiopia

## Abstract

*Most of the time, a certain degree of stretch prominently and incrementally occurs in intimate wear, leisure wear, sportswear, medical textiles etc., during their action. Variations in the stretch gradient would definitely cause changes in the air permeability of knitted fabrics. The influence of variables such as loop length, the presence of an elastomeric component and fabric structure on the air permeability of cotton single jersey and pique knitted fabrics in a stretched state was critically analysed. In this work, changes in the air permeability of cotton jersey samples with and without elastomer were investigated and reported by keeping the samples in static up to an incremental stretch of 40% at a rate of 10% of the stretch gradient, in a dry relaxed state, wet relaxed state and fully relaxed state.*

**Key words:** air permeability, comfort, knitted fabrics, loop length, relaxation, stretch.

## Introduction

Stitch length plays an important role in knitted fabric production in order to meet buyer specifications and consumer satisfaction. Also, the study of stitch length makes the production of knitted fabric with different specifications easier with respect to knitting as well as making it less time consuming [1]. Moreover, since an increase in stitch length results in a wider knitted fabric, the lower the stitch length, the tighter the knitted fabric, and vice-versa. Thus, stitch length has a greater effect on any knitted fabric either in the weft or warp such that the lesser the stitch length, the more compact the fabric structure and the higher the stitch density are, while the higher the stitch length, the looser the fabric and the lesser the stitch density become.

Sampath and Senthilkumar [2] studied the effect of stitch length and knit structure on the wicking, wetting, water absorbency, moisture vapour transmission and air permeability of moisture management of finished micro-denier polyester knitted fabrics. In single jersey fabrics, the wicking length increases continuously with the stitch length for treated fabrics because of the increase in stitch density. In the case of single jersey (untreated) fabric, water absorbency first increases and then decreases tremendously with an increase in the stitch length. Gun's [3] results show that the fibre type (or fibre

fineness) and stitch length affect some physical properties and all of the thermal comfort properties of fabrics significantly [4-6]. Duru and Candan [7] concluded that fibre type as well as stitch length had a significant influence on the liquid transfer characteristic properties of fabrics. Bivainyte, Mikucionienė and Kerpauskas [8] found that the dimensional characteristics of knitted fabrics, i.e. loop length, structure compactness and structure type, have an important influence on the air permeability of a knitted fabric.

Oinuma [9] examined fabric with the lowest courses per centimeter and yarn number (tex) has the highest air permeability values. Therefore, raising the loop length resulted in a looser surface of the fabric, which increased the air permeability. Chidambaram, Govind and Venkataraman [10] studied the thermal properties of single jersey fabrics knitted with different loop lengths and found that water vapour permeability and air permeability show concomitant increases as the linear density and loop length increase. Bhattacharya and Ajmeri [11] investigated knitted structures made from cotton and modal yarns to evaluate the air permeability property for sportswear. The result showed that air permeability is a function of the thickness, tightness factor and porosity of knitted fabrics and that modal single jersey fabrics are considered preferred candidates for warmer climate sportswear, due to their higher air permeability. Prakash, Ramakrishnan, Mani and Keerthana [12] observed that the parameters of thickness, mass/unit area, porosity and air permeability are significantly affected by fibre blend ra-

tios, yarn linear density and loop length. Mavruz and Ogulata's [13] test results show that the relaxation type and some fabric structural parameters affected the air permeability of single jersey fabrics. Afzal, Hussain, Malik and Javed [14] studied the effect of knitting parameters on the air permeability of polyester/cotton interlock fabrics and concluded that loop length is the most predominant factor affecting the air permeability of knitted fabrics. This study is concerned with the influence of loop length on air permeability for knitted fabrics that are dry, wet and in a fully relaxed state.

## Materials and methods

The raw materials used in this work were cotton combed hosiery yarns produced from three different spinning systems, namely ring spinning, compact spinning and core spinning [15-16]. The first two spinning systems were used to produce 19.68 tex count yarn and the third one to manufacture yarn with a nominal count of 19.28 tex having elastomer as the core and cotton yarn as the sheath. Out of the yarn samples produced, ring spun and compact spun samples were knitted from single jersey, single jersey with bare elastomer, single pique and single pique with bare elastomer. The core spun yarn sample was knitted into single jersey and single pique structures. The samples were uniformly knitted with three different machine stitch length variables, namely, 0.27 cm, 0.30 and 0.33 cm to obtain respective fabric tightness factor values of 16.43, 14.79 and 13.44 on a single jersey circular multi-cam track weft knitting machine. The knit fabric samples pro-

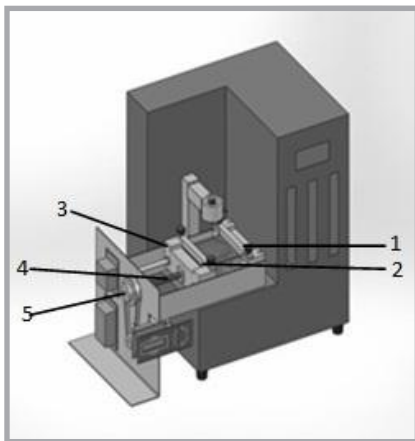

**Figure 1.** Automated fabric stretching device with air permeability tester: 1 – fixed carriage, 2 – moving carriage, 3 – proximity sensor, 4 – screw rod, 5 – timing pulley.

duced were subjected to a dry relaxed state (DRS), wet relaxed state (WRS) and fully relaxed state (FRS). The concept behind the wide range of sampling with structural, loop length and relaxation variables is for the effective comparison of the air permeability behaviour of weft knitted fabrics under unstretched and incrementally stretched states.

Air permeability tests of the single knit fabric samples were carried out as per the test procedure recommended by ASTM D737 using an MAG air permeability tester with a head area of 10 cm<sup>2</sup> and pressure difference of 100 Pa between the two fabric surfaces. An automatic fabric stretching device was designed and fabricated as an attachment to the air permeability tester to test the air permeability of the fabric samples under dynamic conditions (**Figure 1**). It is fully automatic stretching equipment to stretch fabric samples as per the pre-set value. The stretching device can be set with a predetermined degree of fabric stretch either in percentage or mm, and the rate

of extension can also be pre-set in mm per minute. The stored stretch value is displayed on the LCD display after attaining the level of stretch. This instrument is comprised of precise engineering components to get accurate results and is designed to be maintenance free, with stable electronics and a microprocessor controlled menu based on a user-friendly operating system.

All the samples were tested in a relaxed state and incrementally width-wise extended state. For that, a set of five samples of 10 cm x 10 cm were prepared, respectively, for every tightness factor value in all three relaxation patterns. The sample taken for testing was mounted width-wise between the fixed and movable jaws of the automated fabric stretching device, placed above the cylindrical air blow head of the air permeability tester. At that time, the monometer reading was also set to zero. Initially, the mounted sample was tested for its air permeability by blowing air through the fabric sample in a relaxed state till the monometer reading reached the value 1.0, which is equal to a pressure difference of 10 mm head of water. At that stage, the rotometer reading was carefully noted. After that, the sample was subjected to a width-wise incremental extension of 10% by operating the stretching device and subsequently operating the air permeability tester while keeping the initial monometer reading null, till it reached 1.0 again. Then, once again the monometer readings were noted. A similar test procedure was repeated for the width-wise incremental extension of the fabric continuously for 20%, 30% and till 40%, and the respective rotometer readings were noted. Finally, the air permeability of each sample tested was calculated from the rotometer readings, and the average value was found and tabulated.

## Results and discussion

### Effect of loop length on air permeability

In knitted fabrics, loop length is the only non-changing parameter at any state of fabric relaxation. At the same time, samples constructed with various loop length values for a given count will show prominent differences in their geometric, dimensional, mechanical and comfort properties. Thus, the loop length of a knitted fabric has paramount importance. By keeping this in mind, the effect of loop length on the air permeability of the knitted samples was examined.

### Effect of the loop length of ring single jersey (RSJ) knit structures on air permeability

**Table 1** exhibits the effect of loop length on the air permeability of ring single jersey (RSJ) knit samples in unstretched and incrementally stretched states. The ring single jersey 1 sample, which is knitted with a small loop length variable, displays the lowest air permeability values in unstretched and incrementally stretched states uniformly in its dry relaxed state, wet relaxed state and fully relaxed state. It is evenly followed by the ring single jersey 2 and ring single jersey 3 samples, respectively. All the ring single jersey samples show a gradual drop in their permeability during the incremental progress of a stretch, which may due to the longitudinal contraction and resultant increased closeness of the adjacent knitted courses in the fabric samples subjected to a gradual width-wise stretch. The drop is found to be high and more or less similar at a 0-10% stretch gradient for the ring single jersey 1, ring single jersey 2 and ring single jersey 3 samples, irrespective of their loop length difference. After this initial slump, the degree of fall during the remaining stretch gradients is comparatively small difference.

### Effect of the loop length of ring single jersey spandex (RSJS) knit structures on air permeability

**Table 2** exhibits the effect of loop length on the air permeability of ring single jersey spandex (RSJS) knit samples in unstretched and incrementally stretched states. The presence of spandex with regular cotton loops in every alternate knitted course brought a sharp overall fall in the air permeability of these samples both

**Table 1.** Effect of the loop length of ring single jersey (RSJ) knit structures on air permeability.

Sample code	Relaxation state	Loop length, cm	Stitch density (K)	Air permeability in cm <sup>3</sup> /cm <sup>2</sup> .sec				
				Unstretched state	Width-wise incremental stretch			
					0%	10%	20%	30%
RSJ 1	Dry relaxed state	0.27	16.43	121.33	107.33	100.64	94.40	87.10
RSJ 2		0.30	14.79	128.64	114.03	106.06	102.92	98.92
RSJ 3		0.33	13.44	137.50	125.64	116.44	108.80	100.75
RSJ 1	Wet relaxed state	0.27	16.43	69.31	60.00	54.30	47.56	44.50
RSJ 2		0.30	14.79	78.36	67.19	62.10	54.33	47.75
RSJ 3		0.33	13.44	84.85	74.50	67.17	62.25	55.84
RSJ 1	Fully relaxed state	0.27	16.43	64.00	55.56	50.00	45.42	41.65
RSJ 2		0.30	14.79	71.00	62.54	55.12	50.10	44.38
RSJ 3		0.33	13.44	79.30	68.24	62.00	55.12	48.24

in unstretched and stretched conditions when compared to their corresponding ring single jersey (RSJ) samples. At the same time the incremental stretch caused a steady increase in the air permeability values of the samples. The major reason for this increase in air permeability may be due to the gradual increase in the spacing between the knitted loops of adjacent wales and the possible arrest of the longitudinal contraction of knitted courses because of elastomeric yarn. Even though the elastomer is present, the air permeability of the samples is directly proportional to their loop length. Hence, loop length plays a vital role in determining the magnitude of air permeability, while other factors like elastomer are complementary.

### Effect of the loop length of elite single jersey (ESJ) knit structures on air permeability

**Table 3** exhibits the effect of loop length on the air permeability of elite single jersey (ESJ) knit samples in unstretched and incrementally stretched states. Elite single jersey samples show higher air permeability than their counterpart ring single jersey (RSJ) samples. The air permeability behavioral pattern of elite single jersey samples resembles that of ring single jersey samples, except for the difference in numeric values. The loop length of the ESJ sample is directly proportional to air permeability irrespective of the relaxation, which means the sample which is knitted with the smallest loop length exhibits the lowest air permeability and vice-versa. In a dry relaxed state, all the elite single jersey samples show a drastic reduction in their air permeability. The fall is very high at a 0-10% stretch gradient and at a 10-20% stretch gradient, which is slightly lower than the earlier level. Afterwards, the fall is very much stabilised at the subsequent stretch gradients.

It may be the subtle longitudinal contraction of the samples that leads to increased closeness among the adjacent knitted courses during the initial half way lateral expansion. The latter half of the stretch does not cause much distortion in the adjacent courses, thus the fall becomes minimum. The knitted loops of elite single jersey samples in a fully relaxed state attained their equilibrium state, thus the air permeability of elite single jersey samples in an unstretched state decreases.

**Table 2.** Effect of the loop length of ring single jersey spandex (RSJS) knit structures on air permeability.

Sample code	Relaxation state	Loop length, cm	Stitch density (K)	Air permeability in cm <sup>3</sup> /cm <sup>2</sup> .sec				
				Unstretched state	Width-wise incremental stretch			
					0%	10%	20%	30%
RSJS 1	Dry relaxed state	0.27	16.43	22.78	27.42	31.76	35.82	37.90
RSJS 2		0.30	14.79	31.12	34.56	38.17	42.00	44.94
RSJS 3		0.33	13.44	35.83	42.16	47.72	52.72	56.28
RSJS 1	Wet relaxed state	0.27	16.43	15.53	19.11	23.26	26.64	29.76
RSJS 2		0.30	14.79	21.39	25.30	28.72	32.48	34.20
RSJS 3		0.33	13.44	31.64	35.44	39.72	43.85	47.62
RSJS 1	Fully relaxed state	0.27	16.43	9.72	12.50	15.28	18.10	21.50
RSJS 2		0.30	14.79	17.46	21.50	24.20	27.40	29.62
RSJS 3		0.33	13.44	21.00	26.64	30.80	33.62	36.96

**Table 3.** Effect of the loop length of ESJ knit structures on air permeability.

Sample code	Relaxation state	Loop length, cm	Stitch constant (K)	Air permeability in cm <sup>3</sup> /cm <sup>2</sup> .sec				
				Unstretched state	Width-wise incremental stretch			
					0%	10%	20%	30%
ESJ 1	Dry relaxed state	0.27	16.43	133.33	119.33	107.81	103.94	99.50
ESJ 2		0.30	14.79	160.56	124.94	112.17	105.22	98.42
ESJ 3		0.33	13.44	182.34	156.25	139.75	128.96	120.00
ESJ 1	Wet relaxed state	0.27	16.43	76.12	66.56	59.84	52.47	48.50
ESJ 2		0.30	14.79	85.17	73.58	67.94	58.25	52.36
ESJ 3		0.33	13.44	95.00	83.61	74.03	61.81	55.96
ESJ 1	Fully relaxed state	0.27	16.43	69.00	62.68	56.13	50.00	44.46
ESJ 2		0.30	14.79	78.34	72.18	66.46	60.18	56.42
ESJ 3		0.33	13.44	88.80	82.75	77.32	69.48	63.20

**Table 4.** Effect of the loop length of ESJS knit structures on air permeability.

Sample code	Relaxation state	Loop length, cm	Stitch density (K)	Air permeability in cm <sup>3</sup> /cm <sup>2</sup> .sec				
				Unstretched state	Width-wise incremental stretch			
					0%	10%	20%	30%
ESJS 1	Dry relaxed state	0.27	16.43	26.39	29.17	33.24	37.96	39.55
ESJS 2		0.30	14.79	36.11	41.67	43.10	46.65	49.92
ESJS 3		0.33	13.44	42.42	45.67	49.35	54.56	58.12
ESJS 1	Wet relaxed state	0.27	16.43	18.83	24.22	27.55	31.78	33.42
ESJS 2		0.30	14.79	27.86	33.33	36.11	38.89	42.54
ESJS 3		0.33	13.44	34.26	37.50	42.65	46.44	49.68
ESJS 1	Fully relaxed state	0.27	16.43	13.28	16.60	19.94	22.69	25.75
ESJS 2		0.30	14.79	18.72	23.81	27.78	29.17	32.72
ESJS 3		0.33	13.44	27.33	31.11	34.72	38.89	44.44

### Effect of the loop length of elite single jersey spandex (ESJS) knit structures on air permeability

**Table 4** exhibits the impact of loop length on the air permeability of elite single jersey spandex (ESJS) knit samples in unstretched and incrementally stretched states. The elite single jersey spandex samples were knitted by alternate feeding of elastomer. The contribution of elastomer causes a huge drop in the air permeability of all the elite single jersey spandex samples both in unstretched and stretched

states when compared to elite single jersey samples. However, the loop length of the samples plays a crucial role in deciding the fundamental air permeability (i.e) during the unstretched state. Like the previous samples, the loop length and air permeability are directly proportional, and the progressive stretch increases the air permeability, which may be due to the uniform increase in the spacing of adjacent loops. While the increase in the air permeability of the samples during the subsequent stretch gradients is minimised.



**Table 5.** Effect of the loop length of core spun single jersey (CSJ) knit structures on air permeability.

Sample code	Relaxation state	Loop length, cm	Stitch density (K)	Air permeability in cm <sup>3</sup> /cm <sup>2</sup> .sec				
				Unstretched state	Width-wise incremental stretch			
					0%	10%	20%	30%
CSJ 1	Dry relaxed state	0.27	16.43	22.10	26.30	30.64	33.82	36.42
CSJ 2		0.30	14.79	28.83	32.50	36.24	40.20	44.45
CSJ 3		0.33	13.44	34.19	37.95	41.22	45.22	48.97
CSJ 1	Wet relaxed state	0.27	16.43	14.00	17.42	21.70	25.00	29.00
CSJ 2		0.30	14.79	20.84	23.86	27.85	30.75	33.31
CSJ 3		0.33	13.44	29.78	34.83	37.27	40.11	44.83
CSJ 1	Fully relaxed state	0.27	16.43	10.20	14.52	19.34	23.38	27.51
CSJ 2		0.30	14.79	17.13	20.33	24.72	28.64	32.22
CSJ 3		0.33	13.44	25.10	29.44	33.42	36.96	41.12

### Effect of the loop length of core spun single jersey (CSJ) knit structures on air permeability

Table 5 exhibits the impact of loop length on the air permeability of core spun single jersey (CSJ) knit samples in unstretched and incrementally stretched states. In these samples loop length is also directly proportional to air permeability. As the stretch progresses, the air permeability of all the samples increases gradually, which may be due to the uniform increase in the spacing of adjacent knitted loops containing elastomer in the core of the samples. The wet treatment given to the samples before the wet relaxed state and repeated washing and drying before the fully relaxed state allow the knitted loops in the core spun single jersey samples to attain their equilibrium. At the same time, these treatments increase the closeness among the loops. Thus, the core spun single jersey samples with maximum air permeability values in their dry relaxed state – DRS progressively decrease during their wet relaxed state and fully relaxed state.

### Conclusions

The samples knitted with the largest loop length for this research work exhibit maximum air permeability uniform in all three relaxation states when compared to their matching samples and vice-versa. This effect is absolutely due to the higher degree of freedom among the loops of the samples knitted with the largest loop length and vice-versa. The amount of air permeability of a sample both in the unstretched state and incrementally stretched state is found inversely proportional to its loop length. The very same trend prevails whether the samples contain elastomer or not. From the observa-

tion, it is visible that the impact of loop length on the air permeability of the samples tested is independent of the spinning system, fabric structure, fabric relaxation and presence of elastomer. Loop length has an unvaryingly strong effect on air permeability under unstretched and stretched states of the knitted fabric samples. Any increase in the loop length makes a prominent increase in air permeability, and vice-versa, in all the knitted fabric samples.

### References

- Srinivasulu K, Sikka M, Hayavadana J. Study of loop formation process on 1x1 v-bed rib knitting machine: the factors affecting loop length and validation of model. *International Journal of Advanced Research in Engineering and Technology* 2013, 4, 2: 259-270.
- Sampath MB, Senthilkumar M. Effect of Moisture Management Finish on Comfort Characteristics of Microdenier Polyester Knitted Fabrics. *Journal of Industrial Textiles* 2009, 39, 2: 163-173.
- Gun AD. Dimensional, Physical and Thermal Comfort Properties of Plain Knitted Fabrics Made from Modal Viscose Yarns Having Microfibers and Conventional Fibers. *Fibers and Polymers* 2011, 12, 2: 258-267.
- Vasanth Kumar D, Raja D. Influence of Moisture Management Properties on Socks Made from Recycled Polyester, Virgin Cotton and its Blends. *FIBRES & TEXTILES in Eastern Europe* 2020; 28, 4(142): 76-81. DOI: 10.5604/01.3001.0014.0939.
- Vidya T, Prakash C. Comparison of Moisture Management Properties of Plasma Treated Single Jersey Fabric with Different Types of Polyester Yarns. *FIBRES & TEXTILES in Eastern Europe* 2019; 27, 1(133): 32-36. DOI: 10.5604/01.3001.0012.7505.
- Çeven EK, Karakan Günaydin G. Investigation of Moisture Management and Air Permeability Properties of Fabrics with Linen and Linen-Polyester Blend Yarns. *FIBRES & TEXTILES in Eastern Europe* 2018; 26, 4(130): 39-47. DOI: 10.5604/01.3001.0012.1311.
- Duru, SC, Candan C. Effect of repeated laundering on wicking and drying properties of fabrics of seamless garments. *Textile Research Journal* 2013; 83, 6: 591-605.
- Bivainyte A, Mikucionienė D, Kerpauskas P. Investigation on Thermal Properties of Double-Layered Weft Knitted Fabrics. *Material Science* 2012; 18, 2: 167-171.
- Oinuma R. Effect of Stitch Length on Some Properties of Cotton 1× 1 Rib Knitted Fabrics. *Journal of the Textile Machinery Society of Japan* 1990; 36, 3: 91-95.
- Chidambaram P, Govind R, Venkataraman KC. The Effect of Loop Length and Yarn Linear Density on the Thermal Properties of Bamboo Knitted Fabric. *Autex Research Journal* 2011; 11, 4: 102-105.
- Bhattacharyal SS, Ajmeri JR. Investigation of Air Permeability of Cotton & Modal Knitted Fabrics. *International Journal of Engineering Research and Development* 2013; 6, 12: 1-6.
- Prakash, C, Ramakrishnan, G, Mani, K, Keerthana, K. An Investigation of the Relationship Between Blend Ratio, Linear Density and Loop Length on Geometrical and Air Permeability Properties of Bamboo Cotton-Knitted Fabrics. *International Journal of Fashion Design, Technology and Education* 2015; 8, 3, 228-234.
- Mavruz S Ogulata RT. Investigation of Air Permeability of Single Jersey Fabrics with Different Relaxation States. *The Journal of the Textile Institute* 2011; 102, 1: 57-64.
- Afzal A, Hussain T, Malik, MH, Javed Z. Statistical Model for Predicting the Air Permeability of Polyester/Cotton-Blended Interlock Knitted Fabrics. *The Journal of the Textile Institute* 2014; 105, 2: 214-222.
- Buharali G, Omeroglu S. Comparative Study on Carded Cotton Yarn Properties Produced by the Conventional Ring and New Modified Ring Spinning System. *FIBRES & TEXTILES in Eastern Europe* 2019; 27, 2(134): 45-51. DOI: 10.5604/01.3001.0012.9986.
- Günaydin GK, Soydan AS, Palamutçu S. Evaluation of Cotton Fibre Properties in Compact Yarn Spinning Processes and Investigation of Fibre and Yarn Properties. *FIBRES & TEXTILES in Eastern Europe* 2018; 26, 3(129): 23-34. DOI: 10.5604/01.3001.0011.7299.

Received 04.03.2019 Reviewed 02.07.2020