

UDC 631.356.262

**INVESTIGATION OF THE STRUCTURAL MODEL  
OF ADAPTED MACHINE FOR HARVESTING ROOT CROPS**

**Doctor of Technical Sciences, Baranovsky V. M.,**

**PhD in Technical Sciences, Pankiv M. R.**

Ternopil Ivan Pul'uj National Technical University, Ukraine, Ternopil

**Doctor of Technical Sciences, Teslyuk V. V.**

National University of Life and Environmental Sciences of Ukraine, Ukraine,  
Kiev

*Place your method development of deterministic mathematical models that describe the intensification of the process of separation of impurities heap root crops combined working bodies of transport and technological systems to adapt the machine for harvesting root crops. Based on the application of the transformation equations are obtained Laplasa transfer function in the operator form, which describe the functional processes of work of adapted the machine. A method is resulted developments of the determined mathematical models, which describe intensification of process of separation of admixtures from to the lots of root crops by the combined workings organs transport technological systems of the adapted machines are for harvesting of root crops.*

*Key word: technological process, heap of roots, material balance, flow, input weight, components of heap, combined purifier, balance of the masses, input mass.*

**Introduction.** The technological process of root crops production, such as sugar beet, fodder beet and carrot which are valuable raw materials, feed and food crops, one of the most labor-intensive operations is a mechanized harvesting, which accounts for about 25...40 % of labor costs [1, p. 66 – 68].

A significant amount of soil impurities and plant impurities that are digging out by working bodies and transported on the following machine system is the main reason for resorting to the use of energy-intensive heap cleaners.

Modern development of machines for harvesting root crops include development and implementation in agricultural production energy-saving machines that are adapted to the simultaneous harvesting of root crops which belong to different cultures by one machine.

Main criterion for further intensification of the modern agricultural production development is the material and technical base mechanization of all production processes based on providing develop and implementation of highly efficient resource saving technologies of agricultural crops products harvesting [2, p. 10 – 12; 3, p. 7 – 9].

Known results of scientific researches, which are resulted in scientific

labours [3, 50 – 56; 4, c. 7 – 11; 5, c. 232 – 240 but other], as a rule basic principles of work of cleansing workings organs characterize only without the criterion analysis of general aspects and ways of increase of their indexes of quality of work and machines for collection of root crops on the whole.

The problem of raising the technical level of root crop machinery, main evaluation criteria of which are quality indicators of digging out and separation of impurities from the roots, remains especially relevant in terms of further improvement of root crop technology, development and production of which in Ukraine in recent years virtually ceased.

**Formulation of purpose of the article and tasks.** By the purpose of researches, there is an increase of indexes of quality of work of machines for collection of root crops by away intensification of process of separation of admixtures.

Improvement of constructive schemes adapted root crop machines and justify of their parameters should be performed taking into account the specific properties of the environment with which interact with working parts.

This is especially important and actual for the heap cleaners, to which comes fairly significant amount of impurities (impurities of soil – up to 80... 90 %, including stick soil – 3... 5 %, plant impurities – 10... 15 %, remnants of tops in roots heads – 5... 10 % relative to the percentage of total impurities that are 30... 40 %, depending on operating conditions [6, p. 106 – 109]).

In overall context of the difficulty of heap root crops cleaning, which is excavation by working bodies from soil-root environment functionally related to the need of significant separation of different in their physical and mechanical conditions and properties of ground and plant impurities (4...8 kg/l. m). Which are relatively root crops in free (loose soil, small (20...50 mm) and large (100 mm) of soil clods, lost tops, weeds) and in bound (stick soil on the side of the body and remains of tops in root crops heads) states [1, p. 187 – 188].

Thus, from root crops should be separated their maximum-possible number and to provide the necessary quality and performance in accordance with the agro technical requirements.

Given researches is a next step in the further development of methodologies and methods and technological processes development of working groups that are functioning adapted for root crop machines and intended for simultaneous harvesting of sugar root crops, fodder beet and carrot.

**Exposition of basic material of the article.** To develop determined mathematical model of intensification technological process of impurities separation from the heap root crops by the transport and technological systems of adapted root crop machinery fashion functional process of its

work in the form of complex dynamic technical system.

By way of identifying the general functional (Fig. 1) and links of the flowchart intensification of separation technological process impurities from the heap root crops built formalized output structural and functional model serial connection of elementary links, shown in Fig. 2.

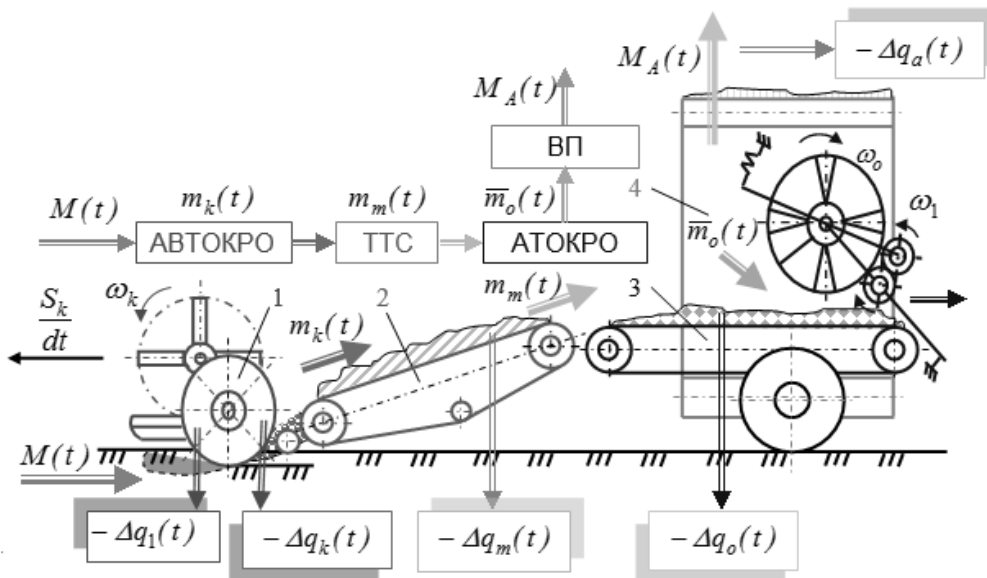

**Fig. 1. Functional chart of intensification of process of separation of admixtures from root crops by the workings organs of machine**

It should be emphasized that the degree of intensification of impurities separation depends on some weight volume capacity of each elementary link and staying time of root crops heap on its working surfaces. Solution of the structural identification of complex dynamic systems conducted by the theory of automatic control, which is most suitable for the study of control systems in the mode of exploitation with existing the influence of random processes and factors, using direct and inverse Laplace transform [7, p. 10–15].

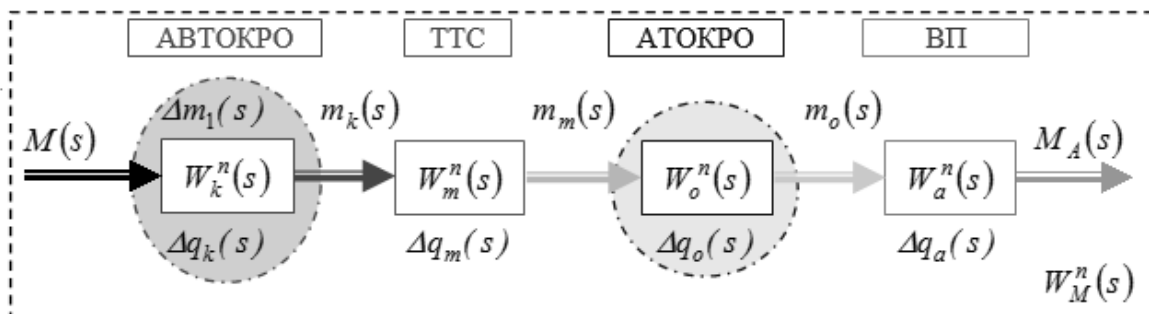

**Fig 2. Output structural and functional model of links connection**

Taking into account consistent manner of structural parts connection and equivalent transfer machine function, which is denoted by  $W_M^n(s)$  (Fig. 1) written as the multiplication  $\prod$  of analytical transfer functions  $W_i^n(s)$  relevant links that form this connection:

$$W_M^n(s) = \prod_{i=1}^n W_i^n(s); W_i^n(s) = \frac{m_{ou.i}(s)}{m_{in.i}(s)} = \frac{1}{T_i s + 1}, \quad (1)$$

where  $m_{ou.i}(s)$ ,  $m_{in.i}(s)$  – image according to Laplace of appropriate link output and input values;

$T_i$  – time constant of corresponding link.

In our case, the time constant  $T_i$  is an adequate time of heap root crops stay on the working surfaces of each transport-technological system of the machine, or the time of heap root crops stay in a certain weight capacity of each link.

The heap number that is processing therein characterizes some weight capacity of each link, or adequate appropriate weight capacity of each link, which is denoted by  $P_i$ .

Defining and substituting the values of weight capacity  $P_i$  and time constant  $T_i$  each link in equation (1) obtained transfer function equation in operator form:

$$W_M^n(s) = \prod_{i=1}^n \left[ \frac{m_{ou.i}(s)}{m_{in.i}(s)} \right] = \prod_{i=1}^n \left( \frac{1}{T_i s + 1} \right) = \prod_{i=1}^n \left[ \left( \frac{P_i}{m_{in.i}(t)} s + 1 \right) \right]^{-1}. \quad (2)$$

The differential equation of structural and functional model of the adapted machines are for harvesting of root crops. (Fig. 2) in the operator form according to (2) is:

$$M_A(s) \left( \frac{P_k + P_m + P_o + P_a}{m_1(t) + m_2(t)} \right) s + M_A(s) = M(s). \quad (3)$$

where  $P_k$ ,  $P_m$ ,  $P_o$ ,  $P_a$  – gravimetric capacity ABТОКРО, TTC, АТОКРО, ВП;  
 $m_1(t)$ ,  $m_2(t)$  – input root mass and impurities that dig working bodies АБТОКРО.

Taking into account (2), (3) obtained differential equation intensification of technological separation process impurities from the heap root crops with transport delay in the classical (time) form:

$$\prod_{i=1}^n \left[ \left( \frac{P_i}{m_{in.i}(t)} \right) \right] \frac{d \left[ \prod_{i=1}^n m_{ou.i}(t) \right]}{dt} = \prod_{i=1}^n m_{in.i} \left( t - \sum_{i=1}^n \tau_i \right) - \prod_{i=1}^n m_{ou.i}(t). \quad (4)$$

Thus

$$\left( \frac{P_k + P_m + P_o + P_a}{m_1(t) + m_2(t)} \right) \frac{d[M_A(t)]}{dt} = M(t - \tau_M) - M_A(t), \quad (5)$$

where  $\tau_M$  – the total time delay of the mass movement in the working areas of the machine.

Functional scheme of intensification process separating impurities from root crops by working bodies combined cleaning system involves two stages of cleaning dug heap root crops from impurities: stage of impurities separation from the heap root crops in the process of movement on a working branch of clearing slide 2 (Fig. 3), which comes from the feeding conveyor 1.

Intensification stage of impurities separation from the heap root crops during its simultaneous cleaning by ellipse screws systems 3 and cleaning by elastic elements 10 which are placed on the drum 9 of the drive shaft 8.

To develop determined mathematical model of intensification separation process of impurities from the heap root crops by combined cleaning system simulate the functional of process of work as a complex dynamic technical system.

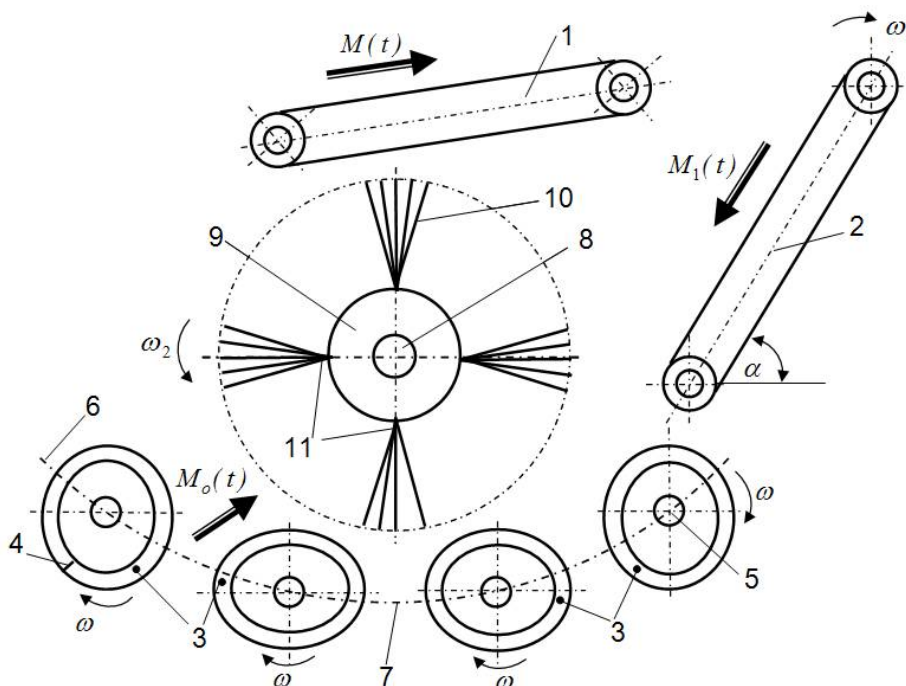

### Fig. 3: Scheme of combined wastewater treatment system

Technological process of impurities separation from root crops by working bodies at each stage and in general is represented by the linear differential equation [1, p. 188; 3, 25 – 26].

$$a_0^{(i)} \frac{d[\Delta m_i(t)]}{dt} = b_0^{(i)} M^{(i)}(t - \tau_i) - c_0^{(i)} M_o^{(i)}(t), \quad (6)$$

where  $a_0^i$ ,  $b_0^i$ ,  $c_0^i$  – variable coefficients in function of the working parameters of clearing systems, the mechanical properties of the soil, root crops productivity which are determined experimentally;

$\Delta m_i(t)$  – separated amount of flow from the input heap root crops by working bodies of combined clearing system,  $i = 1, 2 \dots n$ ;

$\tau_i$  – time delay of the heap mass flow;

$M^{(i)}(t - \tau_i)$ ,  $M_o^{(i)}(t)$  – input and output amount of flow.

In the general context based on material balance, equations weight change in the total mass of inputted heap root crops  $M(t)$  to the feeding conveyor 1 during the time interval described by the equation:

$$\frac{dM}{dt} = \frac{dm_k}{dt} + \frac{d(m_v + m_q + m_n + m_p + m_z)}{dt}, \quad (7)$$

where  $m_k$  – input root crops mass;

$m_v$ ,  $m_q$ ,  $m_n$  – input mass of free, loose soil, clods of soil, stick soil in the underground part root crops;

$m_p$ ,  $m_z$  – input mass of free plant impurities, heads residues on tops of root crops.

Then for any stabilized mode, when rejecting an incoming flows insignificant and workflow of combined clearing system as a whole, taking into account (6), (7) is described by the differential equation:

$$\begin{aligned} a_0^{(k)} \frac{d[\Delta m_k(t)]}{dt} + a_0^{(M)} \frac{d[\Delta M_o(t)]}{dt} &= a_1^{(k)} \frac{d[\Delta m_{1k}(t)]}{dt} + \\ + a_1^{(1)} \frac{d[\Delta m_1(t)]}{dt} + a_o^k \frac{d[\Delta m_{ok}(t)]}{dt} + a_o^{(o)} \frac{d[\Delta m_o(t)]}{dt} &= \\ = b_0 M(t - \tau_1) - c_0^{(1)} M_1(t) + b_0^{(o)} M_1(t - \tau_o) - c_0^{(o)} M_o(t) \end{aligned}, \quad (8)$$

where  $a_0^{(k)}$ ,  $a_0^{(M)}$ ,  $a_1^{(k)}$ ,  $a_1^{(1)}$ ,  $a_o^{(o)}$ ,  $b_0$ ,  $c_0^{(1)}$ ,  $b_0^{(o)}$ ,  $c_0^{(o)}$  – variable coefficients in function of working parameters of clearing slides, ellipse screw system in combination with a drive shaft, physical and mechanical properties of the soil, productivity root crops, etc., which are determined experimentally;

$\tau_1, \tau_o$  – time delay of the heap root crops mass movement in the process, which occurs due to storage, compression, shear, etc. technological masses in the working area of each stage.

A further solution of the differential equation (8) conducted with the use of direct and inverse Laplace transform.

The technological process of work of machine is in addition, formalized foresees the knot of fork of structural transport links on the separate elementary links of the general ground and vegetable admixtures. They in same queue crutch on structural sublinks, accordingly: free and sticking soil, lumps of soil; free vegetable admixtures and tailings of tops on the heads of root crops.

From point of structure of the guided dynamic systems there is strengthening of entrance structural elementary link of ABTOKPO and ATOKPO, or there is a presence of positive feed-back of one structural sublinks in relation to other. That one elementary sublinks is engulfed as a feed-back the second elementary sublinks.

Flow diagrams of connection of sublines of ABTOKPO and ATOKPO, when one sublinks of the dynamic system is engulfed as a positive feed-back the second sublinks it is resulted on Fig. 4.

On the basis of it and the conducted authentication of development of ABTOKPO and ATOKPO process, the eventual formalized is built structurally functional model of process of intensification of separation of admixtures from root crops by the workings organs of machine which is resulted on Fig. 5.

A coefficient which takes into account the degree of diminishing of initial stream of technological mass relative it input stream of every transport system and machine on the whole from point of the guided dynamic systems is an amplification factor which will describe as a coefficient of technological efficiency of work and which will designate through  $K_i = m_{\text{aux}.i}(t) / m_{\text{ex}.i}(t)$ .

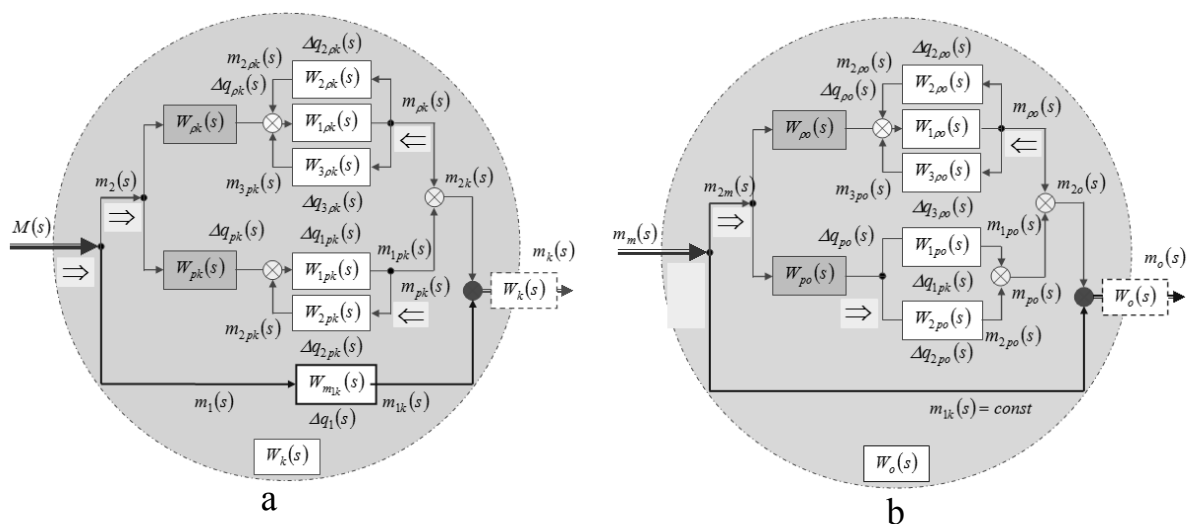

**Fig. 4. Structurally functional model of connection of sublimes of process of intensification of separation of admixtures: a - by a transport system ABTOKPO; b - by a transport system ATOKPO**

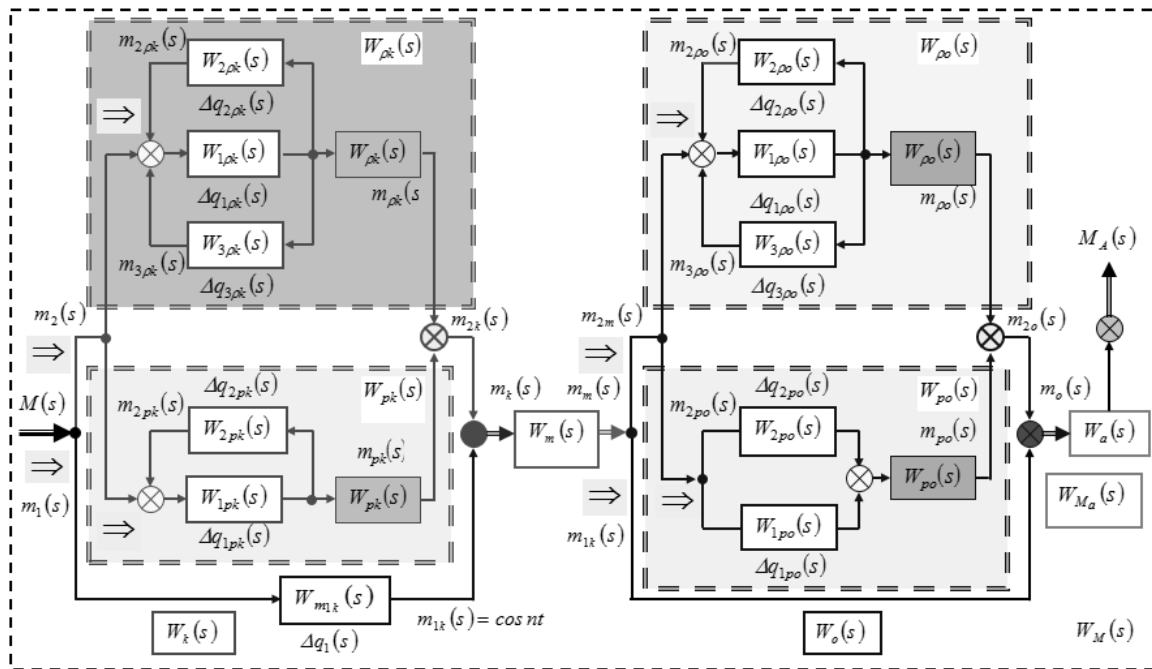

**Fig. 5. Structurally functional model of process of intensification of separation of admixtures from root crops by the workings organs of transport systems of machine**

Pores to it the coefficient of technological efficiency of work of machine is on the whole determined a relation:

$$K_M = \frac{[M_A(t)]}{[M(t)]} = 1 - \frac{[\Delta q_1(t)] + [\Delta q_k(t)] + [\Delta q_m(t)] + [\Delta q_o(t)] + [\Delta q_a(t)]}{[M(t)]}. \quad (9)$$

де  $M(t)$  – input number of stream components after digging;

$M_a(t)$  – the initial number of stream components after work ABTOKPO, ATOKPO, TTC and ВП;

$\Delta q_k(t)$ ,  $\Delta q_m(t)$ ,  $\Delta q_o(t)$ ,  $\Delta q_a(t)$  – separated flow quantity of impurities of the working bodies ABTOKPO, ATOKPO, TTC i ВП;

$\Delta q_1(t)$  – the amount of lost flow roots the working bodies ABTOKPO.

Taking into account the delay of motion of technological the masses in time  $\tau_i$ , transmission function in a statement form from transformation of technological streams of machine which will designate through  $W_i(s)$ , it is possible to present as work of analytical transmission function of aperiodic link of 1-th order and analytical transmission function of link with a transport delay, which will designate through  $W_{3ani}(s) = e^{-s\tau}$ , that:



$$W_i(s) = \frac{m_{\text{ex}.i}(s)}{m_{\text{ex}.i}(s)} = W_i^p(s) \cdot W_{\text{san}.i}(s) = \frac{K_i}{T_i s + 1} e^{-s\tau_i}. \quad (10)$$

Time of finding of stream is on the workings surfaces of transport systems of machine, or became time  $T_i$  can be certain, as attitude of carrying capacity  $P_i$  toward the proper amount of the processed input stream  $m_{\text{ex}.i}(t)$ :

$$T_M = \frac{P_M}{M(t)} = \frac{\sum_{i=1}^n P_i}{M(t)} = \frac{P_k + P_m + P_o + P_a}{m_1(t) + m_2(t)}. \quad (11)$$

Putting the value of coefficient of technological efficiency of work  $K_M$  (9) and permanent time  $T_M$  (11) will get equalization of transmission function  $W_i(s)$  and differential equalization with a transport delay of machine for collection of root crops in a statement form:

$$\begin{aligned} W_M(s) &= \frac{M_A(s)}{M(s)} = W_k(s) \cdot W_m(s) \cdot W_o(s) \cdot W_a(s) = \\ &= \left[ \frac{W_{1pk}(s) \cdot W_{3pk}(s)}{1 + W_{1pk}(s) \cdot [W_{2pk}(s) + 1]} + \frac{W_{1pk}(s)}{1 + W_{1pk}(s) \cdot W_{2pk}(s)} + W_{mk}(s) \right] \times [W_{pm}(s) + W_{pm}(s) + W_{mk}(s)] \times \\ &\times \left[ \frac{W_{1po}(s) \cdot W_{3po}(s)}{1 + W_{1po}(s) \cdot [W_{2po}(s) + 1]} + W_{1po}(s) + W_{2po}(s) + W_{mk}(s) \right] \times [W_{pa}(s) + W_{pa}(s) + W_{mk}(s)] = \frac{K_M}{T_M s + 1} e^{-s\tau_M} \end{aligned} \quad (12)$$

$$M_A(s) \left[ \frac{P_k + P_m + P_o + P_a}{m_1(t) + m_2(t)} s + 1 \right] = M(s) \cdot \left[ 1 - \frac{\Delta q_1(t) - \Delta q_k(t) - \Delta q_m(t) - \Delta q_o(t) - \Delta q_a(t)}{M(t)} \right] e^{-s\tau_M}. \quad (13)$$

Then differential equalization of intensification of technological process of separation of admixtures from root crops with a transport delay in a classic (to the sentinel) form will look like:

$$\begin{aligned} (P_k + P_m + P_o + P_a) \frac{d[M_A(t)]}{dt} &= \\ &= M(t) [M(t) - \Delta q_1(t) - \Delta q_k(t) - \Delta q_m(t) - \Delta q_o(t) - \Delta q_a(t)] e^{-s\tau_M} - M(t) \end{aligned} \quad (14)$$

$$P_M \frac{d[M_A(t)]}{dt} = M(t) \cdot [M_A(t) \cdot e^{-s\tau_M} - 1]. \quad (15)$$

Differential equalizations (14) are got, (15) is the determined mathematical models, which characterize dependence of change of intensification of technological process of separation of admixtures on root

crops during time from structurally kinematics parameters of workings organs of machine and terms of work, or modes of operations of machine, agrotechnical and mechanical descriptions of root crops and mechanical properties of soil.

**Conclusion.** The mathematical models of process of intensifications of separation of admixtures are developed from root crops allow at analytical level to conduct optimization structurally kinematics parameters of workings organs and modes of operations of machine for collection of root crops.

Complex estimation of parameters of machine, or coefficient of technological efficiency, permanent time and time of delay of motion of streams of technological the masses allows to conduct more deep and detailed analysis of technological process of intensification of separation of admixtures from root crops.

### **References:**

1. Pogorelyi L.V. *Beetroot-lifting machine: history, design, theory, forecast* / L.V. Pogorelyi, M.V. Tatianko - K. : Phoenix, 2004. – 232 p.
2. Adamchuk V.V. *About development and creation in Ukraine of agricultural machines of modern level* / V.V. Adamchuk, Bulgakov, V.M., Ivanishin, V.V. // *Collection of scientific labours of the Vinnytsya national agrarian university. Series: Engineerings sciences.* – Tom 2 (66). – Issue 11. – Vinnytsya, 2012. – pp. 8–14.
3. Gevko R.B. *Extractings and cleansing devices of beet-lifting machines: constructing and calculation* / R.B. Gevko. – Ternopil, 1997. – 120 p.
4. Pogorelyi M. *Conformities to law of development of beet-lifting technique and ground of rational outlines of domestic machines* / Maksym Pogorelyi // *Technique of APK.* – 1999. – No 3. – pp. 8–12.
5. Bulgakov V.M. *Theory beet-lifting machines: monograph* / V.M. Bulgakov, M.I. Chernovol, N.A. Sviren. – Kirovograd, 2009. – 256 p.
6. Rogatinskiy R.M. *Design of processes of co-operation of screw workings organs with root crops* / R.M. Rogatinskiy // *Announcer of the National agrarian university.* – K., 1997. – T. 1. – pp. 103–108.
7. Valyukh O.A. *Elementi theories of automatic control. Linear systems of continuous action* / O.A. Valyukh, V.M. Maksimiv. – Lviv, 2002. – 123 p.