

Investigations into HEM_{12δ} Mode Radiating From a Cylindrical Dielectric Resonator Antenna

Archita Banerjee and D. Guha

¹Institute of Radio Physics and Electronics, University of Calcutta
92 A P C Road, Kolkata 700009, India
E-mails: archita@ieee.org, dguha@ieee.org.

Abstract

HEM_{12δ} mode has been recently excited successfully in a CDRA by the present authors. This is with high gain broadside radiation characteristics. In this paper, we have examined the limitations of the newly proposed feeding mechanism and possibility of using this mode for practical purpose.

1. Introduction

Cylindrical dielectric resonator was the first candidate which was reported as the dielectric resonator antenna (DRA) in 1983 by Long et al. [1]. The possible resonant modes were analyzed in [2] and [3], and corresponding resonant frequencies were verified by using the cavity- method measurements. Among the first five modes mentioned in [2] and [3], only two i.e. HEM_{11δ} and TM_{01δ} could be used for radiation purposes in cylindrical dielectric resonator (CDRA) for more than last two decades. HEM_{11δ} mode shows the broadside radiation pattern and the TM_{01δ} mode shows the omni-directional monopole- like radiation around the DRA. HEM_{12δ} mode appears immediately after the HEM_{11δ} mode [3]. Its field configurations indicate the possibility of yielding linearly polarized broadside radiation. We have been able to excite HEM_{12δ} mode using a non resonant microstrip patch (NMP) as discussed in [4].

The feeding mechanism for this design is not very straight forward. Critical optimizations needed in every stage. In this paper we have tried to address this from the view point of practical design. A thorough investigation is provided. Results obtained using EM simulator [5] are presented to indicate some significant characteristics. Experimental verification is under progress. This primarily needs a cylindrical dielectric block with $\epsilon_r=38$. Fabrication of DRA with $\epsilon_r=38$, $a=5.5\text{mm}$ and $h=4.5\text{mm}$ will be fabricated soon in a national material laboratory and the measured results will be provided.

2. Excitation of HEM_{12δ} mode

The electric fields portrayed in [3] indicate that those due to HEM_{12δ} mode do not show any horizontal plane of symmetry which allows a metallic ground plane or rest to hold the structure. This is essential for practical applications and the known radiating modes like, HEM_{11δ} and TM_{01δ} do provide the basic boundary conditions. Indeed HEM_{12δ} mode is possible in an isolated DRA only. This is a challenge to excite this type of mode in practice. Therefore, we have introduced a current sheet touching CDRA at its bottom surface and have realized using a non radiating microstrip (NMP) etched on a regular PTFE substrate. An elementary idea is reported in [4]. Fig 1 shows the schematic diagram of the NMP and Fig 2 shows the schematic diagram of the antenna using proposed technique. For this study, we have chosen a CDRA same as in [2], [3] for comparison with their theoretical data and we are able to excite the mode of our interest i.e. HEM_{12δ} successfully [4]. The antenna parameters are as follows: dielectric constant of the DRA= 38, height =4.6 mm, and diameter =10.5 mm; and probe position from central axis $\rho=2\text{mm}$ and for the non resonating microstrip patch (NMP): the dielectric constant of the substrate (ϵ_r, ϵ_s) = 2.33, height (t) = 1.575 mm, diameter of the substrate and the ground plane (D) = 40 mm, probe-dia = 1.3 mm.

3. Results

The feed and resonator properties are examined in this section through a series of figures. The non resonant microstrip patch is excited by a coaxial probe does not resonate itself. For a chosen location of $\rho=2\text{mm}$, the input S_{11} is examined in Fig 3. The patch alone with varying radius does not show any resonance over a wide range of frequency band. This non resonant patch is used to feed a CDRA of given parameters with HEM_{126} mode.

It is observed that the excitation of HEM_{126} mode in the DRA critically depends on feed structures, in particular the location of the excitation probe. This is examined in Fig 4 for different heights of the DRA, other DRA parameters being unchanged. As h increases optimum feed location needs a shift from central part to patch boundary. Change of h also causes change in resonant frequency. Thus it is observed that using the same patch a DRA of different height can be excited with HEM_{126} mode only by changing the location of the excitation probe.

For a DRA, if we just change the dielectric constant keeping its dimensions unchanged, the resonant frequency change. But this does not require any optimization of the probe. These characteristics are shown in Fig 5 for $\epsilon_{r,d}$ value varying from 20 to 40. It is important to note that so long the radius of the dielectric is fixed the radius of feeding patch needs no change or optimization. But the patch radius plays a significant role in feeding and optimizing. This is examined in Fig 6. For a given dimension of the DRA the patch radius is varied from 3 mm to 5mm. Significant change in overall S_{11} values is revealed. 4 mm to 5 mm value of r appears to be most suitable to excite the HEM_{126} mode. This is further confirmed examining electric field vectors of the excited mode in the DRA as shown in Fig 7. It is relevant to note that in all the Figs. 4- 6, the second resonance in each case represents the mode of our interest. Figure 7 actually shows that mode. The simulated radiation patterns at the centre of the operating frequency are shown in Fig 8. The radiation along the broadside is evident and the predicted peak gain is more than 6 dBi. The H-plane pattern is perfectly symmetrical, although a mild side lobe is apparent in the E-plane. An asymmetry in E-plane pattern is observed. Finally the observations are presented tabulated form in Table 1. One can easily visualize the possibility of exciting HEM_{126} mode in a CDRA employing the proposed technique and also its limitations.

4. Figures and Tables

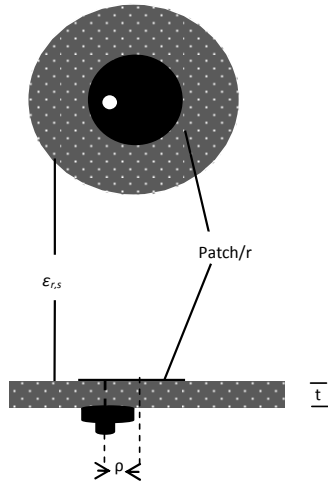

Fig.1. Schematic diagram of the NMP.

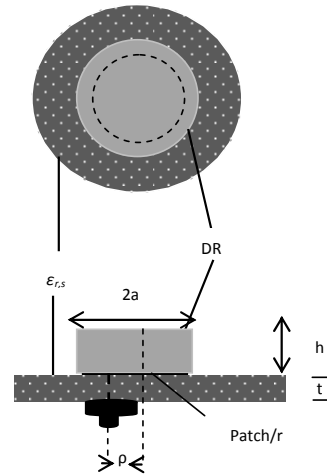

Fig.2. Schematic diagram of a CDRA with proposed feeding mechanism.

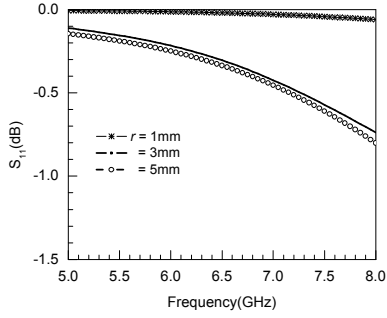

Fig.3. Simulated S_{11} vs. frequency by changing the radius of NMP (patch alone).
NMP: $\epsilon_{r,s} = 2.33$, $t = 1.575$ mm, $D = 40$ mm, probe-dia = 1.3 mm.

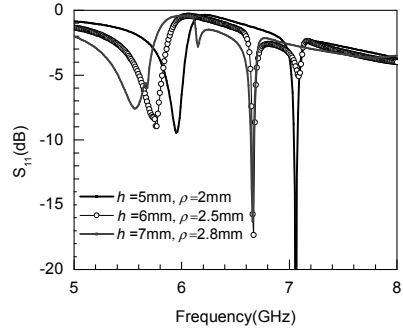

Fig.4. Simulated S_{11} vs. frequency in a CDRA by changing its height. NMP: $\epsilon_{r,s} = 2.33$, $t = 1.575$ mm, $D = 40$ mm, probe-dia = 1.3 mm, DR: $\epsilon_{r,d} = 38$, $a = 5.25$ mm, $r = 5$ mm.

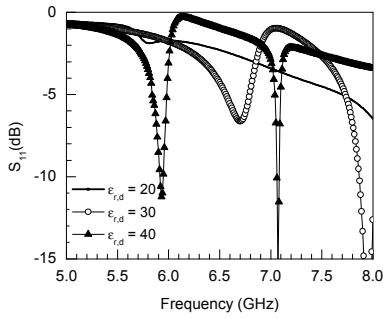

Fig.5. Simulated S_{11} vs. frequency in a CDRA by changing its dielectric constant. $\rho = 2$ mm, $r = 5$ mm and other parameters as in Fig 4.

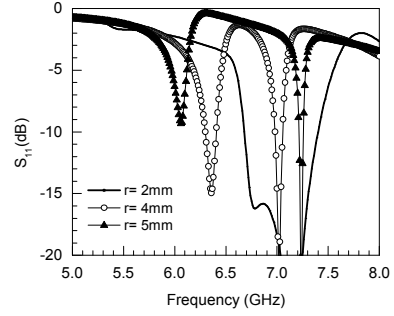

Fig.6. Simulated return loss characteristics of a CDRA by changing its patch radius (NMP/feed). $h = 4.6$ mm and other parameters as in Fig 4.

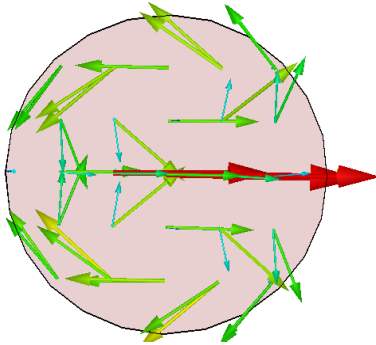

Fig.7. Electric fields due to $HEM_{12\delta}$ mode in a CDRA(simulated diagram).

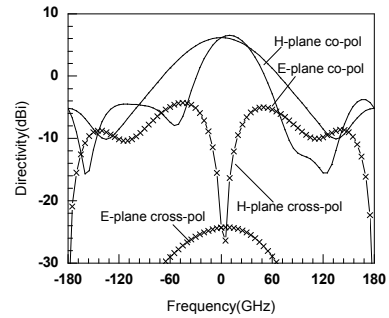

Fig.8. Radiation characteristics of $HEM_{12\delta}$ mode obtained at 7.23 GHz. $h = 4.6$ mm, $\rho = 2$ mm and other parameters as in Fig 4.

TABLE 1
Resonant Frequencies of HEM_{12δ} Mode in a Cylindrical DRA
NMP: $\epsilon_{r,s} = 2.33$, $t = 1.575$ mm, $D = 40$ mm, probe-dia = 1.3 mm

Observation 1			Observation 2			Observation 3		Observation 4	
DR: a=5.25mm, $\epsilon_{r,d}=38$, r=5mm.			DR: h=4.6, $\epsilon_{r,d}=38$, r=5mm.			DR: h=4.6, a=5.25mm, $\rho=2$ mm, $\epsilon_{r,d}=38$.		DR: h=4.6, a=5.25mm, $\epsilon_{r,d}$ =38, $\rho=2$ mm, r=5mm.	
Varying Height DR (h) (mm)	Resonance Frequency (GHz)	ρ (mm)	Varying Radius DR (a) (mm)	Resonance Frequency (GHz)	ρ (mm)	Varying Radius NMP(r) (mm)	Resonance Frequency (GHz)	Varying Dielectric Constant DR($\epsilon_{r,d}$)	Resonance Frequency (GHz)
4.6	7.24	2	5.25	7.29	2	2	6.78	40	7.07
5	7.06	2	7.25	5.63	2	3	6.84	38	7.29
6	6.66	2.5	9.25	4.41	3	4	7.02	35	7.49
7	6.65	2.8	10.5	4.3	3.5	5	7.29	30	7.95
8	6.43	2.8	11.25	4.14	4			25	HEM _{12δ} Mode not excited
9.2	6.25	3						20	Do
10	6.17	3						15	Do
								10	Do

5. Conclusion

The present study indicates the possibilities and limitations in exciting HEM_{12δ} mode in CDRA. This newly explored mode can be excited by using a non resonating microstrip patch, which is interesting bearing a new crunch in it. This inspires further research on CDRA both for theoretical and experimental aspects.

6. References

- [1] S. A. Long, M. W. McAllister, and L. C. Shen, "The resonant cylindrical cavity antenna," *IEEE Trans. Antennas Propagat.*, vol. 31, pp. 406–412, May, 1983.
- [2] A. W. Glisson, D. Kajfez, and J. James, "Evaluation of modes in dielectric resonators Using a surface a surface integral equation formulation," *IEEE Trans. Microwave Theory Tech.*, vol. 31, no.12, pp. 1023-1029, Dec. 1983.
- [3] D. Kajfez, A. W. Glisson, and J. James, "Computed Modal Field Distributions for Isolated Dielectric Resonators." *IEEE Trans. Microwave Theory Tech.*, vol. 32, no.12, pp. 1609-1616, Dec.1984.
- [4] D.Guha, A.Banerjee and Y.M.M. Antar "New radiating mode in a cylindrical DRA to produce broadside high gain radiation"*IEEE AP-S* August 2010.
- [5] High Frequency Structure Simulator (HFSS) v11.1, Ansoft.