

CALIFORNIA INSTITUTE OF TECHNOLOGY  
GUGGENHEIM AERONAUTICAL LABORATORY

MEMORANDUM No. 31

AERONAUTICAL LABORATORY

 CALIFORNIA INSTITUTE OF TECHNOLOGY

## HYPERSONIC RESEARCH PROJECT

Memorandum No. 31

February 1, 1956

### INVISCID HYPERSONIC FLOW OVER BLUNT-NOSED SLENDER BODIES

by

Lester Lees

ENGINEERING LIBRARY

TECHNICAL REPORT



ARMY ORDNANCE CONTRACT NO. DA-04-495-Ord-19

GUGGENHEIM AERONAUTICAL LABORATORY  
CALIFORNIA INSTITUTE OF TECHNOLOGY  
Pasadena, California

HYPERSONIC RESEARCH PROJECT

Memorandum No. 31

February 1, 1956

INVISCID HYPERSONIC FLOW OVER  
BLUNT-NOSED SLENDER BODIES

by

Lester Lees

  
Clark B. Millikan, Director  
Guggenheim Aeronautical Laboratory

ARMY ORDNANCE CONTRACT NO. DA-04-495-Ord-19  
Army Project No. 5B0306004  
Ordnance Project No. TB3-0118  
OOR Project No. 1600-PE

## SUMMARY

At hypersonic speeds the drag/area of a blunt nose is much larger than the drag/area of a slender afterbody, and the energy contained in the flow field in a plane at right angles to the flight direction is nearly constant over a downstream distance many times greater than the characteristic nose dimension. The transverse flow field exhibits certain similarity properties directly analogous to the flow similarity behind an intense blast wave found by G. I. Taylor and S. C. Lin. Conditions for constant energy show that the shape of the bow shock wave  $R(x)$  not too close to the nose is given by  $R/d = K_1(\gamma) \left(\frac{x}{d}\right)^{\frac{1}{2}}$  for a body of revolution, and by  $R/d = K_0(\gamma) \left(\frac{x}{d}\right)^{2/3}$  for a planar body, where  $d$  is nose diameter, or leading-edge thickness. A comparison with the experiments of Hammitt, Vas, and Bogdonoff on a flat plate with a blunt leading-edge at  $M_\infty = 13$  in helium shows that the shock wave shape is predicted very accurately by this analysis. The predicted surface pressure distribution is somewhat less satisfactory.

Energy considerations combined with a detailed study of the equations of motion show that flow similarity is also possible for a class of bodies of the form  $r_b \sim x^m$ , provided that  $m' \leq m \leq 1$ , where  $m' = 3/4$  for a planar body and

$$m' = \frac{3/2(\gamma + 1)}{3\gamma + 2}$$

for a body of revolution. When  $m < m'$  the shock shape is not similar to the body shape, and except for the constant energy flows the entire flow field some distance from the nose must depend to some extent on the details of the nose geometry.

By again utilizing energy and drag considerations one finds that at hypersonic speeds the inviscid surface pressures generated by a blunt nose are larger than the pressures produced by boundary layer growth on a flat surface over a distance from the nose of order  $l$ , where

$$l/d \approx \frac{1}{15} \left( \frac{Re_d}{M_\infty^2} \right)^3 .$$

(Here  $Re_d$  is free-stream Reynolds number based on leading-edge thickness.)

Thus at  $M_\infty = 15$  the viscous interaction effects should be important for  $Re_d < 10^3$ , but somewhere in the range  $1500 < Re_d < 2000$  the inviscid effects must spread rapidly over the plate surface, and certainly for  $Re_d > 3000$  the inviscid pressure field is dominant and determines the boundary layer development, skin friction and heat transfer over the forward portion of the body. These rough estimates are in qualitative agreement with the experimental results of References 7 and 9.

## LIST OF SYMBOLS

Free stream quantities are denoted by the subscript " $\infty$ ", while the subscript "b" denotes quantities evaluated at the body surface.

a sound speed

A constant

C Chapman-Rubens factor in relation  $\frac{\mu}{\mu_{\infty}} = C(T/T_{\infty})$

$C_p$  pressure coefficient,  $\frac{P - P_{\infty}}{\frac{1}{2} \rho_{\infty} U_{\infty}^2}$

d nose diameter or leading-edge thickness

D drag

E energy in transverse flow field

$F(z) = \frac{P(z)}{\rho_{\infty} v_s^2}$

k geometric index

$l$  influence length

L body length

m exponent,  $r_b \sim x^m$

M Mach number,  $u/a$

p pressure

Q any physical quantity

r distance normal to body axis or chord line (x- axis)

R distance of shock wave from x- axis

$Re_d$  Reynolds number,  $\frac{\rho_{\infty} U_{\infty} d}{\mu_{\infty}}$

|            |  |
|------------|--|
| t          | time   |
| T          | absolute temperature   |
| u, v       | velocity components parallel and normal to x- axis                             |
| $v_s$      | shock velocity in direction normal to x- axis, $U_\infty \frac{dR}{dx}$        |
| x          | distance along body axis or chord line, measured from forward stagnation point |
| z          | r/R  |
| a          | exponent, $\frac{1 - m}{m}$  |
| $\gamma$   | ratio of specific heats, $C_p/C_v$   |
| $\theta_s$ | shock angle with respect to x- axis  |
| $\mu$      | absolute viscosity   |
| $\rho$     | density  |
| $\tau$     | $r_b \max/L$   |
| $\Phi(z)$  | $\frac{v(z)}{v_s}$   |
| $\Psi(z)$  | $\rho(z)/\rho_\infty$  |

## 1. Introduction

When a finite amount of energy is suddenly released at some "point" in a gas initially at rest, G. I. Taylor<sup>1</sup> showed that the radius of the intense spherical blast wave generated by the explosion grows like

$$R = F_1(\gamma) \left( \frac{E}{\rho_\infty} \right)^{1/5} t^{2/5} .$$

The flow field in the wake of the shock wave exhibits a certain similitude, in the sense that the pressure, density, and outflow velocity are described by relations of the form

$$\frac{Q(r)}{Q(R)} = f\left(\frac{r}{R}\right) .$$

This similarity holds only in the intermediate zone not too close to the origin of the explosion, (where the theory predicts that  $T \longrightarrow \infty$  and  $\rho \longrightarrow 0$ ), yet not so far away that the shock strength has decayed to a level where the strong shock approximations are no longer applicable. Taylor's analysis was later extended to the case of a cylindrical blast wave by S. C. Lin<sup>2</sup>, who found that

$$R = F_2(\gamma) \left( \frac{E}{\rho_\infty} \right)^{1/4} t^{3/4}$$

in this case. Lin also remarked that according to Hayes'<sup>3</sup> concept of hypersonic similitude this relation for  $R(t)$  should describe the shape of the bow shock wave behind an unyawed, axially-symmetric body travelling at a uniform hypersonic velocity. The axial flow velocity is nearly constant, provided that the shock angle  $\theta_s$  is not too large, and the flow in a transverse plane fixed in space behind the body resembles the flow generated by the explosion of a long highly-concentrated cylindrical charge at the time  $t = 0$ . Here  $t \longrightarrow \frac{x}{U_\infty}$ , and the energy  $E$

per unit length of charge is identified with the total drag of the body.

The purpose of this note is to point out that these considerations are equally applicable to the shock wave generated by a blunt nose of finite radius on an unyawed slender body. At hypersonic speeds the drag of the nose per unit cross-sectional area is much larger than the drag/area of an afterbody with a uniformly small slope in the meridian plane. To be specific, the drag of a blunt nose of diameter  $d$  (or leading-edge of thickness  $d$ , for a planar body) is given by

$$D_N \approx \frac{1}{2} \rho_\infty U_\infty^2 d^{k+1}$$

while the drag of a conical (or wedge-like) afterbody of half-angle  $\theta$  and length  $L$ , for example is  $\sim$

$$\frac{1}{2} \rho_\infty U_\infty^2 (\theta^2) (\theta L)^{k+1}$$

where  $k = 0$  for a planar body and  $k = 1$  for a body of revolution. The drag of the afterbody becomes comparable with the nose drag only when

$$\frac{L}{d} \sim \frac{1}{\theta \frac{k+3}{k+1}}$$

In other words, the shape of the bow shock wave, the inviscid flow field and the surface pressure distribution on a slender body are dominated by the blunt nose or leading-edge over a downstream distance many times greater than the characteristic nose dimension. The analogy with a constant-energy, non-steady similar flow of the type investigated by Taylor and Lin is complete for the particular case of a blunt nose followed by a cylindrical afterbody ( $\theta = 0$ ). In this case the shock shape is described by



$$R \sim \left( \frac{\frac{1}{2} \rho_{\infty} U_{\infty}^2 d^2}{\rho_{\infty}} \right)^{1/4} \left( \frac{x}{U_{\infty}} \right)^{1/2}, \text{ or } R/d = K_1 (\gamma) \left( \frac{x}{d} \right)^{1/2} .$$

As shown below, the analogy is readily extended to planar bodies, where it is complete for the case of a flat surface with a blunt leading-edge at zero angle of attack. These rough considerations suggest that it would also be worthwhile to investigate the more general case in which the energy of the transverse flow is increasing with distance from the nose, but the shape of the body is such that flow similarity is preserved. The corresponding non-steady flow problems are the expanding sphere, expanding cylinder, and motion of a piston in a long, straight tube.

## 2. Similar Flows: Energy and Drag Considerations

Taylor's assumption of flow similarity in a fixed transverse plane is satisfied only for "strong" shocks, where

$$v(R) \approx \frac{2}{\gamma+1} v_s, \quad \frac{p(R)}{\rho_{\infty}} \approx \frac{2}{\gamma+1} v_s^2, \quad \text{and} \quad \frac{\rho(R)}{\rho_{\infty}} \approx \frac{\gamma+1}{\gamma-1} .$$

The strong shock approximation in turn is applicable only when

$$\frac{\gamma-1}{2} \frac{v_s^2}{a_{\infty}^2} = \frac{\gamma-1}{2} M_{\infty}^2 \theta_s^2 \gg 1 . \quad *$$

In addition,

$$v(R) \sim R^{-a}, \quad \text{or} \quad R^a \frac{dR}{dt} = A (\text{const.}), \quad \text{and} \quad R = \left( \frac{A}{U_{\infty}^m} \right)^{1/m} x^m$$

where

$$a = \frac{1-m}{m} .$$

\* Previous experience with hypersonic similarity suggests that this approximation is useful when

$$\frac{\gamma-1}{2} M_{\infty}^2 \theta_s^2 > 2 \longrightarrow 3 .$$

Also, the boundary condition  $v(r_b) = U_\infty \frac{dr_b}{dx}$  on the body requires that  $v(r_b) = z_b v_s$ , or  $z_b = \frac{r_b}{R} = \text{const.}$  if flow similarity is to exist; i. e.,  $r_b \sim x^m$ , and the shock and body are similar.

When these conditions are satisfied, we may write

$$v(r, t) = A \frac{\Phi(z)}{R^\alpha}, \quad \frac{p(r, t)}{\rho_\infty} = A^2 \frac{F(z)}{R^{2\alpha}}, \quad \text{and}$$

$$\frac{p(r, t)}{\rho_\infty} = \Psi(z), \quad \text{where } z = r/R \quad (\text{Fig. 1}), \quad \text{and the energy } E$$

associated with the flow field in a transverse plane is expressed as follows:\*

$$(1) \quad E = 2^k \pi^{k'} \int_{r_b}^R \rho \left( c_v T + \frac{v^2}{2} \right) r^k dr, \quad \text{or}$$

$$(1a) \quad E = 2^k \pi^{k'} \rho_\infty A^2 R^{k+1-2\alpha} \int_{z_b}^1 \left( \frac{F}{\gamma-1} + \frac{1}{2} \Psi \Phi^2 \right) z^k dz,$$

where  $k = k' = 0$  for planar flow;  $k = k' = 1$  for axially-symmetric flow;  $k' = 1$  and  $k = 2$  for non-steady spherical flow. An energy balance shows that

$$(2) \quad \frac{dE}{dt} \equiv U_\infty \frac{dE}{dx} = 2^k \pi^{k'} r_b^k p_b v_b; \quad \text{in other words, the}$$

energy of the fluid motion changes at a rate given by the rate at which work is done by the pressure forces acting on the fluid along the body surface. Evidently from Eq. (1a),  $E = \text{const.}$  when  $2\alpha = 1 + k$ , or

$$m = \frac{2}{3+k}, \quad \text{and by Eq. (2) } v_b = z_b = 0 \quad \text{everywhere, except right at}$$

---

\* The quantity  $E$  has the dimensions of energy/area for planar flows, energy/length for axially-symmetric (cylindrical) flows, and the energy itself for non-steady spherical flows.

the nose. For spherical flow  $\alpha = 3/2$ ,  $m = 2/5$ , and  $R \sim t^{2/5}$  (Taylor<sup>1</sup>); for axially-symmetric flow  $\alpha = 1$ ,  $m = \frac{1}{2}$ , and  $R \sim x^{\frac{1}{2}}$  (Lin<sup>2</sup>); for planar flow  $\alpha = \frac{1}{2}$ ;  $m = 2/3$ , and  $R \sim x^{2/3}$ . Also, when  $2\alpha < 1 + k$ , or  $m > \frac{2}{3+k}$ , then  $\frac{dE}{dt} > 0$ , and  $v_b > 0$ ,  $z_b > 0$ . For a positive body slope (or an expanding sphere, cylinder, or piston), similar solutions exist (if at all) only for  $m > \frac{2}{3+k}$ . \* The same conclusion is reached by considering the pressure drag. For these bodies,

$$D = 2^k \pi^{k'} \int_0^L r_b^k P_b \left( \frac{dr_b}{ds} \right) ds = \text{const.} \int_0^R R^{k-2\alpha} dR,$$

or

$$D = \text{const.} \left\{ R^{k+1-2\alpha} \Big|_0^R \right\}; \quad \text{the drag is finite only when } m \geq \frac{2}{3+k}.$$

These conditions for the existence of similar solutions are necessary but not sufficient ones. A study of the mathematical properties of the equations of motion shows\*\* that except for the special case  $m = \frac{2}{3+k}$ , non-singular similar solutions exist only when  $m' \leq m \leq 1$ , where  $m' = 3/2 \frac{\gamma + 1}{\gamma(2+k) + 2}$ . For planar flow  $m' = 3/4$ ,

---

\* Stewartson<sup>4</sup> also found the restriction  $m > 2/3$  in his study of boundary-layer shock-wave interaction over a planar body of shape  $r_b \sim x^m$ . For  $m < 2/3$  the lateral velocity given by the inviscid solution at the outer edge of the boundary layer is negative, and he was unable to match it with the positive (outward) lateral velocity given by the sum of the body slope and the boundary layer growth. However, no explanation was offered for this behavior, and the special significance of the case  $m = 2/3$  was not explored.

\*\* A detailed analysis is contained in a forthcoming GALCIT Hypersonics Technical Report.

independently of  $\gamma$ ; for axially-symmetric flow  $m' = 0.59$  for  $\gamma = 1.2$ ,  $m' = 0.58$  for  $\gamma = 1.4$ , and  $m' = 0.57$  for  $\gamma = 5/3$ . Included within this range of values of  $m$  are of course the wedge and cone ( $m = 1$ ), and also the "hypersonic optimum shape"  $r_b \sim x^{3/4}$ , or body of revolution of minimum zero-lift drag for a given fineness ratio, as determined from Newtonian impact theory neglecting centrifugal force by Eggers, Dennis, and Resnikoff<sup>5</sup>. By including centrifugal force, J. D. Cole<sup>6</sup> obtained the value  $m = 2/3$  for this optimum shape. For planar flow Cole obtains an optimum shape with  $m = 0.87$ ; both of his cases also lie within the range  $m' \leq m \leq 1$ .

When these similar solutions do exist one expects them to provide a good approximation to the pressure and velocity fields not too close to the blunt nose. The surface pressure distribution (for example) is given by

$$\frac{P(r_b)}{P_\infty} = \frac{m^2}{z_b} F(z_b) \tau^2 \frac{M_\infty^2}{\left(\frac{x}{L}\right)^{2(1-m)}}, \quad \text{or}$$

$$C_p(r_b) = \frac{2m^2}{z_b} F(z_b) \tau^2 \left(\frac{x}{L}\right)^{2(1-m)}, \quad * \quad \text{where } \tau = \frac{r_{b \max}}{L},$$

For these bodies, the results obtained by utilizing any one of the purely "local" hypersonic approximations, such as tangent-wedge (or cone), or Newtonian plus centrifugal force, are similar in form, which gives one some confidence in these approximations, provided that  $m > m'$ .

---

\* Here  $F(z_b)$  are functions of  $m$  and  $\gamma$ ; their values are now being determined for a few cases of interest.

When  $m < m'$ , however, we conclude that the shock shape is not similar to the body shape, and (except for the special case  $m = \frac{2}{3+k}$ ) the entire flow field some distance from the nose must depend to some extent on the details of the nose geometry. It remains to be seen whether any simple local hypersonic approximation is applicable to a blunt-nosed slender body in these cases.

### 3. Comparison Between Theory and Experiment for a Flat Plate with a Blunt Leading-Edge

A clear test of the analogy between hypersonic flow over a blunt-nosed slender body and the constant-energy Taylor-type flow is provided by the experimental investigation carried out by Hammitt, Vas, and Bogdonoff<sup>7</sup> on a flat plate in the Princeton helium tunnel. The blunt leading edge is formed by taking a plane cut normal to the upper plate surface, which is parallel to the oncoming flow. The lower surface is inclined at  $10^\circ$  to the flow, but does not influence the upper surface. In these tests the Mach number ranges from 11.4 to 13.8, and the shock angles are such that the assumptions of the strong shock theory are fully satisfied. Shock wave shapes were determined from interferograms over a range of leading-edge thicknesses

$$0.17 \times 10^{-3} \text{ in.} \leq d \leq 59 \times 10^{-3} \text{ in.}, \text{ or } 120 \leq Re_d \leq 70.6 \times 10^3.$$

For  $Re_d > 16 \times 10^3$  viscous effects are negligible (see below), and the empirical fit to the data presented in Ref. 7 is  $R = 1.36 d^{0.34} x^{0.66}$ , which is reasonably close to the theoretical prediction  $R = K_0(\gamma) d^{1/3} x^{2/3}$  in this case. (See Fig. 2) The factor  $K_0(\gamma)$  is currently being

evaluated, but is certainly of order unity.\*

For reasons that are not yet clear the prediction of the surface pressure distribution along the flat surface is much less satisfactory. According to the similarity theory

$$\Delta P/P_\infty \approx \frac{0.4 M_\infty^2}{(x/d)^{2/3}},$$

and the calculated values are of the correct order within a factor of 1.5 - 2.0. But the final empirical fit to the data<sup>7</sup> is

$$\frac{\Delta P}{P_\infty} = 0.0161 \frac{M_\infty^3}{(x/d)^{0.5}}$$

in the range  $4 \times 10^3 \leq Re_d \leq 70.6 \times 10^3$ . Bertram<sup>9</sup> measured pressure distributions for a similar geometry in the 11 x 11 inch heated air tunnel at the NACA Langley Laboratory at  $M = 6.86$ , and his data for  $Re_d = 1960$  show an inverse 2/3 power dependence on  $x/d$  in the range  $10 < x/d < 70$  (approx.). However, the range of over-pressures and leading-edge thickness is not wide enough to permit any definite conclusions to be drawn.\*\*

For thinner leading-edges the effects of boundary layer-external

---

\* For the constant energy flows ( $m = \frac{2}{3+k}$ ) solutions of the equations of motion are obtained in closed form. This property was discovered first for the spherical (Taylor) case by R. Latter<sup>8</sup>, but it holds also for axially-symmetric and planar flows.

\*\* Unfortunately most of the considerable body of data on shock shapes for blunt-nosed bodies of revolution falls in the range where the parameter  $\frac{\gamma-1}{2} M_\infty^2 \theta_s^2$  is of order  $1 \rightarrow 2$ , or less. An experimental study of the hemisphere-cylinder is now in progress at GALCIT in the  $M = 7.8$  air tunnel.

flow interaction are clearly discernible in the Princeton experiments.<sup>7</sup>

The question naturally arises as to the relative importance of the inviscid pressure field associated with the blunt leading-edge and the self-induced pressure generated by boundary layer growth. An estimate of the relative magnitude of these two effects can be obtained by considering the energy introduced into the transverse flow field by the blunt leading-edge and by the pressure drag,  $D_V$ , associated with the "effective" body shape. The quantity  $D_V$  is given by

$$D_V = l \cdot \rho_\infty u_\infty^2 \frac{M_\infty^{3/2} C^{3/4}}{(Re_l)^{3/4}} \left( \frac{4p_o \cdot \delta_o}{\gamma} \right)$$

according to the strong interaction theory<sup>10</sup>, and the nose drag is comparable with  $D_V$  when

$$l/d = \left( \frac{\gamma}{8p_o \delta_o} \right)^4 \left( \frac{Re_d}{CM_\infty^2} \right)^3 \approx \frac{1}{15} \left( \frac{Re_d}{M_\infty^2} \right)^3$$

for both helium and air. Thus at  $M_\infty = 15$  the viscous interaction effects should be important for  $Re_d < 10^3$ , but somewhere in the range  $1500 < Re_d < 2000$  the inviscid effects must spread rapidly over the plate surface, and certainly for  $Re_d > 3000$  the inviscid pressure field is dominant and determines the boundary layer development, skin friction and heat transfer over the forward portion of the body. These rough estimates are in qualitative agreement with the experimental results of References 7 and 9.

The author would like to express his appreciation to Dr. Julian D. Cole for stimulating and helpful discussions of this problem.

## REFERENCES

1. Taylor, G. I.: The Formation of a Blast Wave by a Very Intense Explosion. Part I. Theoretical Discussion. Part II. The Atomic Explosion of 1945. Proc. Roy. Soc. (A), Vol. 201, No. 1065, pp. 159-186, 22 March 1950.
2. Lin, S. C.: Cylindrical Shock Waves Produced by Instantaneous Energy Release. Journ. of App. Phys., Vol. 25, No. 1, pp. 54-57, January, 1954.
3. Hayes, W. D.: On Hypersonic Similitude. Quarterly of Applied Math., Vol. 5, No. 1, pp. 105-106, April, 1947.
4. Stewartson, K.: On Leading Edge Effects in Hypersonic Flow. Private Communication.
5. Eggers, A. J., Jr., Dennis, D. H., and Resnikoff, M. M.: Bodies of Revolution for Minimum Drag at High Supersonic Air Speeds. NACA RM A51K27, February 25, 1952.
6. Cole, J. D.: Newtonian Flow Theory for Slender Bodies. Private Communication.
7. Hammitt, A. G., Vas, I. E., and Bogdonoff, S. M.: Leading-Edge Effects on the Flow over a Flat Plate at Hypersonic Speeds. Princeton University, Aeronautical Engineering Department Report No. 326, September, 1955.
8. Latter, R.: Similarity Solution for a Spherical Shock Wave. Journ. App. Phys., Vol. 26, No. 8, pp. 954-960, August, 1955.
9. Bertram, M. H.: Viscous and Leading-Edge Thickness Effects on the Pressures on the Surface of a Flat Plate in Hypersonic Flow. Journ. Aero. Sci., Vol. 21, No. 6, pp. 430-431, June, 1954.
10. Lees, L.: On the Boundary Layer Equations in Hypersonic Flow and their Approximate Solutions. Journ. Aero. Sci., Vol. 20, No. 2, pp. 143-145, February, 1953. See also, Proc. 5th International Aeronautical Conference (IAS-RAS), Hypersonic Flow, Section 3.



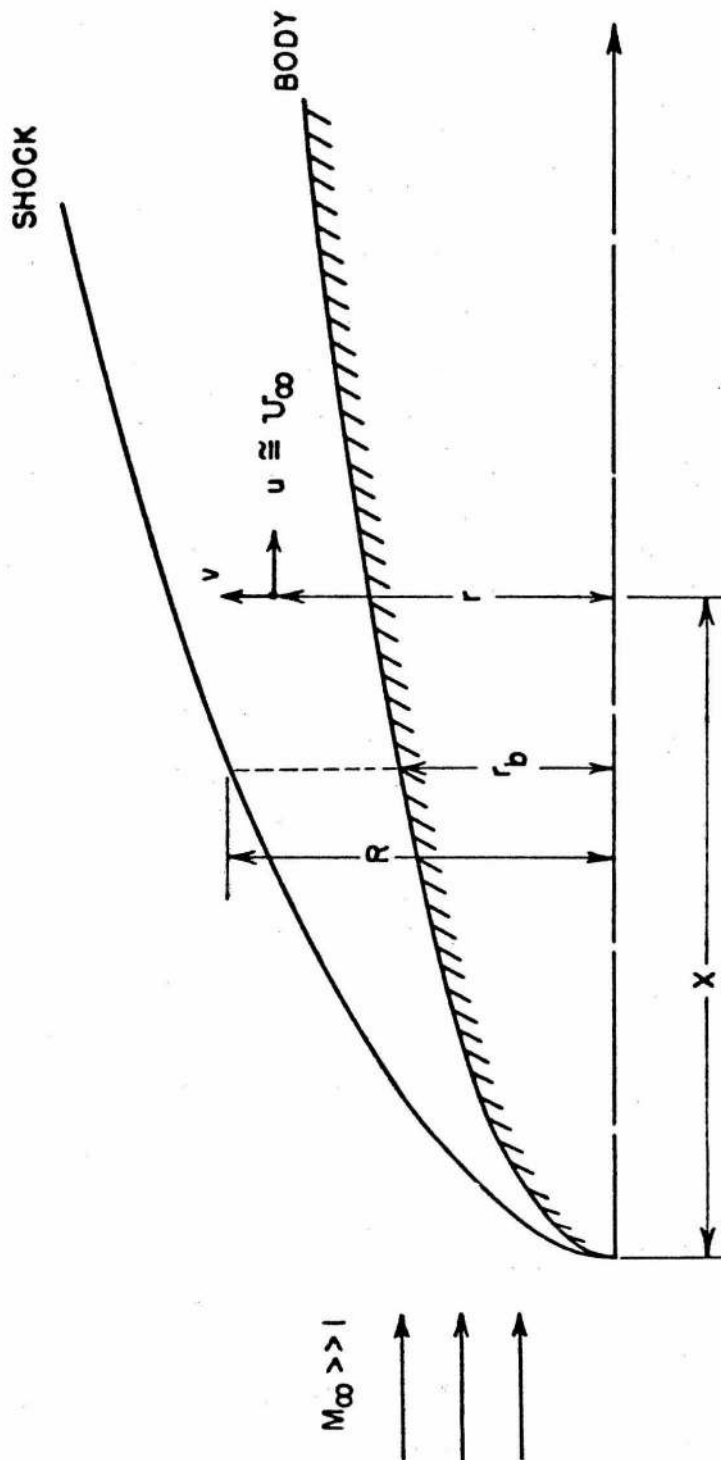

FIG. 1 - HYPERSONIC INVISCID FLOW OVER A BLUNT-NOSED  
SLENDER BODY

$M_\infty = 12.7$   
 $Re_d = 15,010$   
 $d = 14.56 \times 10^{-3} \text{ in.}$

○ EXPERIMENTAL (REF. 7)

—  $\frac{R}{d} = 1.36 \left( \frac{x}{d} \right)^{\frac{2}{3}}$

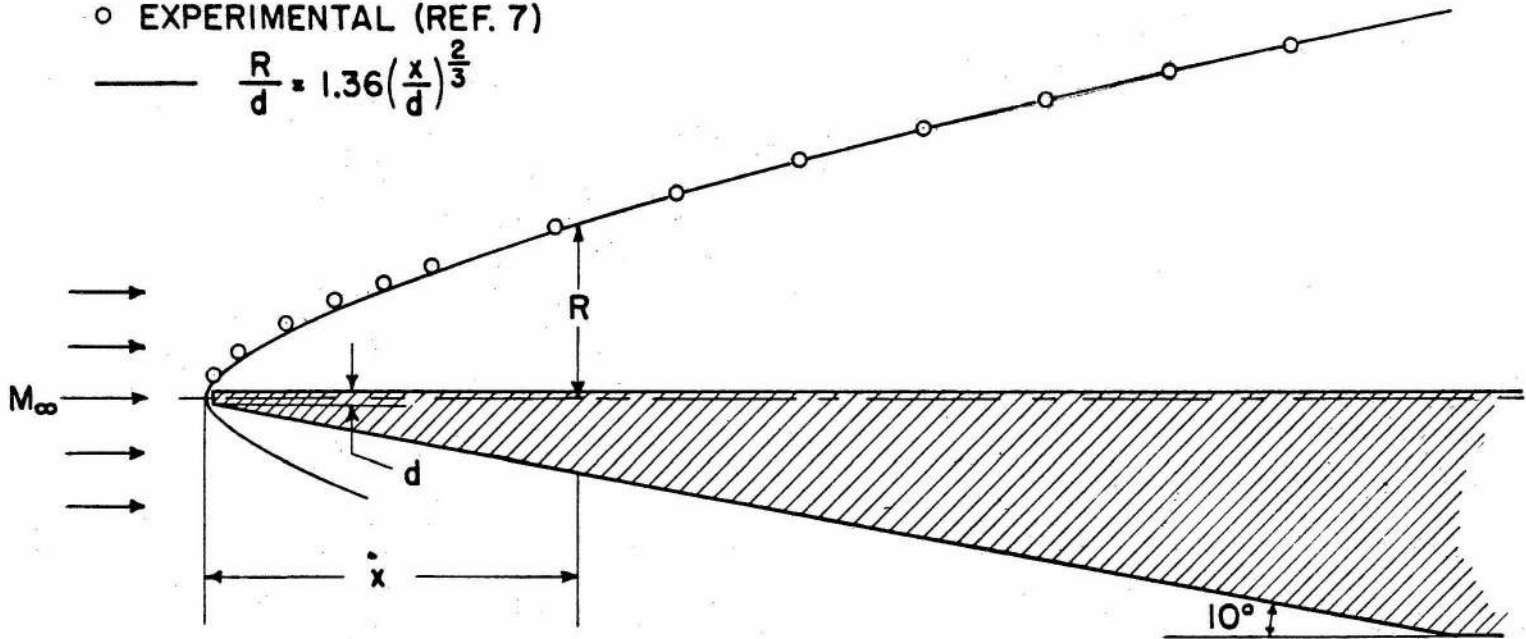

FIG. 2 SHOCK WAVE SHAPE FOR FLAT PLATE WITH BLUNT LEADING EDGE

GUGGENHEIM AERONAUTICAL LABORATORY  
CALIFORNIA INSTITUTE OF TECHNOLOGY

HYPERSONIC RESEARCH PROJECT  
Contract No. DA-04-495-Ord-19

DISTRIBUTION LIST

U. S. Government Agencies

Los Angeles Ordnance District  
55 South Grand Avenue  
Pasadena, California  
Attention: Mr. E. L. Stone  
2 copies

Western Division  
Office of Scientific Research  
Hq., Air Research and  
Development Command  
P. O. Box 2035  
Pasadena 2, California  
Attention: Dr. Morton Alperin

Office of the Chief of Ordnance  
ORDTB - Ballistic Section  
The Pentagon  
Washington 25, D. C.  
Attention: Mr. G. Stetson  
2 copies

Office of Ordnance Research  
Box CM, Duke Station  
Durham, North Carolina  
10 copies

Exterior Ballistic Laboratories  
Aberdeen Proving Ground  
Maryland  
Attention: Mr. C. L. Poor

Ballistic Research Laboratories  
Aberdeen Proving Ground  
Maryland  
Attention: Dr. Joseph Sternberg

Commanding General  
Headquarters  
Air Research and Development  
Command  
P. O. Box 1395  
Baltimore 3, Maryland  
Attention: RDTRRF

U. S. Naval Ordnance Laboratory  
White Oak  
Silver Spring 19, Maryland  
Attention: Dr. R. K. Lobb

Commander  
Western Development Division  
P. O. Box 262  
Inglewood, California

Chief of Ordnance  
Department of the Army  
Washington 25, D. C.  
Attention: ORDTB  
For Transmittal To  
Department of Commerce  
Office of Technical Information

Commanding General  
Redstone Arsenal  
Huntsville, Alabama  
Attention: Technical Library

Air Force Armament Center  
Air Research and Development Command  
Eglin Air Force Base, Florida  
Attention: Technical Library

Navy Department  
Bureau of Ordnance  
Technical Library  
Washington 25, D. C.  
Attention: Ad-3

Armed Services Technical Information  
Agency  
Document Service Center  
Knott Building  
Dayton 2, Ohio  
Attention: DSC-SD22  
5 copies

Lewis Flight Propulsion Laboratory  
National Advisory Committee  
for Aeronautics  
Cleveland Municipal Airport  
Cleveland 11, Ohio  
Attention: Dr. A. Silverstein

Lewis Flight Propulsion Laboratory  
National Advisory Committee  
for Aeronautics  
Cleveland Municipal Airport  
Cleveland 11, Ohio  
Attention: Dr. J. C. Eppard

Ames Aeronautical Laboratory  
National Advisory Committee  
for Aeronautics  
Moffett Field, California  
Attention: Mr. H. Julian Allen

Ames Aeronautical Laboratory  
National Advisory Committee  
for Aeronautics  
Moffett Field, California  
Attention: Dr. D. Chapman

Ames Aeronautical Laboratory  
National Advisory Committee  
for Aeronautics  
Moffett Field, California  
Attention: Dr. A. C. Charters

Ames Aeronautical Laboratory  
National Advisory Committee  
for Aeronautics  
Moffett Field, California  
Attention: Mr. A. J. Eggers

Ames Aeronautical Laboratory  
National Advisory Committee  
for Aeronautics  
Moffett Field, California  
Attention: Dr. M. K. Rubesin

Holomann Air Force Base  
Alamogordo, New Mexico  
Attention: Dr. G. Eber

Langley Aeronautical Laboratory  
National Advisory Committee  
for Aeronautics  
Langley Field, Virginia  
Attention: Mr. M. Bertram

Langley Aeronautical Laboratory  
National Advisory Committee  
for Aeronautics  
Langley Field, Virginia  
Attention: Dr. A. Buseman

Langley Aeronautical Laboratory  
National Advisory Committee  
for Aeronautics  
Langley Field, Virginia  
Attention: Mr. C. McLellan

Langley Aeronautical Laboratory  
National Advisory Committee  
for Aeronautics  
Langley Field, Virginia  
Attention: Mr. John Stack

National Advisory Committee  
for Aeronautics  
1512 H Street, N. W.  
Washington 25, D. C.  
Attention: Dr. H. L. Dryden, Director

National Bureau of Standards  
Department of Commerce  
Washington 25, D. C.  
Attention: D. G. B. Schubauer

Naval Ordnance Laboratory  
White Oak  
Silver Spring, Maryland  
Attention: Dr. H. Kurzweg

U. S. Naval Air Missile Test Center  
Point Mugu, California  
Attention: Mr. J. H. Carrington,  
Chief Engineer

U. S. Naval Ordnance Test Station  
China Lake  
Inyokern, California  
Attention: Dr. A. L. Bennett

Commander  
Wright Air Development Center  
Wright-Patterson Air Force Base  
Ohio  
Attention: WCLSR

Commander  
Wright Air Development Center  
Wright-Patterson Air Force Base  
Ohio  
Attention: WCLSW

Commander  
Wright Air Development Center  
Wright-Patterson Air Force Base  
Ohio  
Attention: WCRRD

Commander  
Arnold Engineering Development Center  
Tullahoma, Tennessee  
Attention: AEORL

Director of Research and  
Development, DCS/D  
Headquarters, USAF  
Washington 25, D. C.  
Attention: AFDRD-RE

Office of Naval Research  
 Department of the Navy  
 Washington 25, D. C.  
 Attention: Capt. Wm. Fortune

Bureau of Aeronautics  
 Department of the Navy  
 Room 2 w 75  
 Washington 25, D. C.  
 Attention: Mr. F. A. Louden

Air University Library  
 Maxwell Air Force Base  
 Alabama

Commander  
 U. S. Naval Proving Ground  
 Dahlgren, Virginia

Technical Information Service  
 P. O. Box 62  
 Oak Ridge, Tennessee

Director  
 Naval Research Laboratory  
 Washington 25, D. C.

Commanding Officer  
 Office of Naval Research  
 Branch Office  
 Navy, 100  
 FPO  
 New York, N. Y.  
 2 copies

Mechanics Division  
 Office of Scientific Research  
 Air Research and  
 Development Command  
 P. O. Box 1395  
 Baltimore, Maryland

Chief of Ordnance  
 Department of the Army  
 ORDGU-SE  
For Transmittal To  
Canadian Joint Staff  
 Washington, D. C.

Deputy Chief of Staff  
 for Logistics  
 U. S. Army  
 Research and Development  
 Division  
 Attention: Research Branch  
 Washington, D. C.

Commanding General  
 White Sands Proving Ground  
 Las Cruces, New Mexico

Universities and Non-Profit Organizations

Brown University  
 Graduate Division of Applied Mathematics  
 Providence 12, Rhode Island  
 Attention: Prof. W. Prager

Brown University  
 Graduate Division of Applied Mathematics  
 Providence 12, Rhode Island  
 Attention: Dr. R. Probststein

University of California at Berkeley  
 Berkeley, California  
 Attention: Prof. S. A. Schaaf

University of California at Los Angeles  
 Department of Engineering  
 Los Angeles 24, California  
 Attention: Dr. L. M. K. Boelter

Case Institute of Technology  
 Cleveland, Ohio  
 Attention: D. G. Kuerti

Catholic University of America  
 Department of Physics  
 Washington 17, D. C.  
 Attention: Prof. K. F. Herzfeld

Cornell Aeronautical Laboratory  
 Buffalo, New York  
 Attention: Dr. A. Flax

Cornell Aeronautical Laboratory  
 Buffalo, New York  
 Attention: Dr. Ira G. Ross, Director

Cornell University  
 Graduate School of Aeronautical Engineering  
 Ithaca, New York  
 Attention: Dr. A. Kantrowitz

Cornell University  
 Graduate School of Aeronautical Engineering  
 Ithaca, New York  
 Attention: D. W. R. Sears

Harvard University  
 Department of Applied Physics  
 and Engineering Science  
 Cambridge 38, Massachusetts  
 Attention: Dr. A. Bryson

Harvard University  
Department of Applied Physics  
and Engineering Science  
Cambridge 38, Massachusetts  
Attention: Dr. H. W. Emmons

The Johns Hopkins University  
Applied Physics Laboratory  
8621 Georgia Avenue  
Silver Spring, Maryland  
Attention: Dr. F. N. Frenkiel

The Johns Hopkins University  
Department of Aeronautical  
Engineering  
Baltimore 18, Maryland  
Attention: Dr. F. H. Clauser

The Johns Hopkins University  
Department of Mechanical  
Engineering  
Baltimore 18, Maryland  
Attention: Dr. S. Corrsin

The Johns Hopkins University  
Department of Aeronautical  
Engineering  
Baltimore 18, Maryland  
Attention: Dr. L. Kovasznay

Lehigh University  
Physics Department  
Bethlehem, Pennsylvania  
Attention: Dr. R. Emrich

University of Maryland  
Institute of Fluid Dynamics  
and Applied Mathematics  
College Park, Maryland  
Attention: Director

University of Maryland  
Department of Aeronautical  
Engineering  
College Park, Maryland  
Attention: Dr. S. F. Shen

Massachusetts Institute of Technology  
Cambridge 39, Massachusetts  
Attention: Dr. A. H. Shapiro

Massachusetts Institute of Technology  
Department of Aeronautical  
Engineering  
Cambridge 39, Massachusetts  
Attention: Dr. G. Stever

Massachusetts Institute of Technology  
Department of Aeronautical Engineering  
Cambridge 39, Massachusetts  
Attention: Prof. M. Finston

Massachusetts Institute of Technology  
Department of Aeronautical Engineering  
Cambridge 39, Massachusetts  
Attention: Prof. J. R. Markham

University of Michigan  
Department of Aeronautical Engineering  
East Engineering Building  
Ann Arbor, Michigan  
Attention: Dr. Arnold Kuethe

University of Michigan  
Department of Aeronautical Engineering  
East Engineering Building  
Ann Arbor, Michigan  
Attention: Prof. W. C. Nelson

University of Michigan  
Department of Physics  
Ann Arbor, Michigan  
Attention: Dr. O. Laporte

University of Minnesota  
Department of Aeronautical Engineering  
Minneapolis 14, Minnesota  
Attention: Dr. R. Hermann

University of Minnesota  
Department of Mechanical Engineering  
Division of Thermodynamics  
Minneapolis, Minnesota  
Attention: Dr. E. R. G. Eckert

National Science Foundation  
Washington 25, D. C.  
Attention: Dr. R. Seeger

New York University  
Department of Aeronautics  
University Heights  
New York 53, New York  
Attention: Dr. J. F. Ludloff

New York University  
Institute of Mathematics and Mechanics  
45 Fourth Street  
New York 53, New York  
Attention: Dr. R. W. Courant

North Carolina State College  
Department of Engineering  
Raleigh, North Carolina  
Attention: Prof. R. M. Pinkerton

Ohio State University  
Aeronautical Engineering Department  
Columbus, Ohio  
Attention: Prof. A. Tifford

Ohio State University  
Aeronautical Engineering Department  
Columbus, Ohio  
Attention: Prof. G. L. von Eschen

Pennsylvania State College  
Department of Aeronautical  
Engineering  
State College, Pennsylvania  
Attention: Prof. M. Lessen

Polytechnic Institute of Brooklyn  
Aerodynamic Laboratory  
527 Atlantic Avenue  
Freeport, New York  
Attention: Dr. A. Ferri

Polytechnic Institute of Brooklyn  
Aerodynamic Laboratory  
527 Atlantic Avenue  
Freeport, New York  
Attention: Dr. P. Libby

Princeton University  
Palmer Physical Laboratory  
Princeton, New Jersey  
Attention: Dr. W. Bleakney

Princeton University  
Aeronautics Department  
Forrestal Research Center  
Princeton, New Jersey  
Attention: Prof. S. Bogdonoff

Princeton University  
Aeronautics Department  
Forrestal Research Center  
Princeton, New Jersey  
Attention: Dr. L. Crocco

Purdue University  
School of Aeronautical Engineering  
Lafayette, Indiana  
Attention: Librarian

Rensselaer Polytechnic Institute  
Aeronautics Department  
Troy, New York  
Attention: Dr. R. P. Harrington

Rensselaer Polytechnic Institute  
Aeronautics Department  
Troy, New York  
Attention: Dr. T. Y. Li

Rouss Physical Laboratory  
University of Virginia  
Charlottesville, Virginia  
Attention: Dr. J. W. Beams

University of Texas  
Defense Research Laboratory  
500 East 24th Street  
Austin, Texas  
Attention: Prof. M. J. Thompson

University of Washington  
Department of Aeronautical Engineering  
Seattle 5, Washington  
Attention: Prof. R. E. Street

University of Wisconsin  
Department of Chemistry  
Madison, Wisconsin  
Attention: Dr. J. O. Hirschfelder

University of Illinois  
Department of Aeronautical Engineering  
Urbana, Illinois  
Attention: Prof. C. H. Fletcher

Institute of the Aeronautical Sciences  
Library  
2 East 64th Street  
New York 21, New York

Midwest Research Institute  
4049 Pennsylvania  
Kansas City 11, Missouri  
Attention: Mr. M. Goland, Director  
for Engineering Sciences

#### Industrial Companies

Aerophysics Development Corp.  
17411 Posetano Road  
Pacific Palisades, California  
Attention: Dr. W. Bollay

ARO, Inc.  
P. O. Box 162  
Tullahoma, Tennessee  
Attention: Mr. R. Smelt

ARO, Inc.  
Tullahoma, Tennessee  
Attention: Dr. B. Goethert

AVCO Manufacturing Corp.  
2385 Revere Beach Parkway  
Everett 49, Massachusetts  
Attention: Librarian

Bell Aircraft Corp.  
P. O. Box 1  
Buffalo 5, New York  
Attention: Mr. R. J. Woods

Boeing Airplane Company  
P. O. Box 3107  
Seattle 14, Washington  
Attention: Mr. G. Snyder

Chance Vought Aircraft, Inc.  
P. O. Box 5907  
Dallas, Texas  
Attention: Mr. J. R. Clark

CONVAIR  
Division of General Dynamics Corp.  
San Diego 12, California  
Attention: Mr. C. Bossart

CONVAIR  
Division of General Dynamics Corp.  
Fort Worth 1, Texas  
Attention: Mr. R. H. Widmer

Douglas Aircraft Company  
Santa Monica, California  
Attention: Mr. H. Luskin

General Electric Company  
Research Laboratory  
Schenectady, New York  
Attention: Dr. H. T. Nagamatsu

General Electric Company  
Campbell Avenue Plant  
Schenectady, New York  
Attention: Mr. G. Metcalf

The Glenn L. Martin Company  
Baltimore 3, Maryland  
Attention: Mr. G. S. Trimble, Jr.

Grumman Aircraft Engineering Corp.  
Bethpage, New York  
Attention: Mr. C. Tilgner, Jr.

Hughes Aircraft Company  
Culver City, California  
Attention: Dr. A. E. Puckett

Lockheed Aircraft Corp.  
Missiles Division  
Van Nuys, California  
Attention: Dr. J. Charyk

McDonnell Aircraft Corp.  
Lambert-St. Louis Municipal Airport  
P. O. Box 516  
St. Louis 3, Missouri  
Attention: Mr. K. Perkins

North American Aviation, Inc.  
Aeronautical Laboratory  
Downey, California  
Attention: Dr. E. R. Van Driest

Northrop Aircraft, Inc.  
1001 East Broadway  
Hawthorne, California  
Attention: Mr. E. Schmued

Ramo-Wooldridge Corporation  
409 East Manchester Blvd.  
Inglewood, California  
Attention: Dr. Louis G. Dunn

The RAND Corporation  
1700 Main Street  
Santa Monica, California  
Attention: Librarian

The RAND Corporation  
1700 Main Street  
Santa Monica, California  
Attention: Mr. E. P. Williams

Republic Aviation Corporation  
Conklin Street  
Farmingdale, L. I., New York  
Attention: Dr. W. J. O'Donnell

United Aircraft Corp.  
East Hartford, Connecticut  
Attention: Mr. J. G. Lee

#### Internal

Jet Propulsion Laboratory  
California Institute of Technology  
4800 Oak Grove Drive  
Pasadena 2, California  
Attention: Reports Group

Dr. Peter P. Wegener  
Jet Propulsion Laboratory

Goddard Professor  
Jet Propulsion Center  
California Institute of Technology

Aeronautics Library  
California Institute of Technology

Hypersonic Staff and Research Workers  
(22 copies)  
Hypersonic Files (3 copies)