

General Disclaimer

One or more of the Following Statements may affect this Document

- This document has been reproduced from the best copy furnished by the organizational source. It is being released in the interest of making available as much information as possible.
- This document may contain data, which exceeds the sheet parameters. It was furnished in this condition by the organizational source and is the best copy available.
- This document may contain tone-on-tone or color graphs, charts and/or pictures, which have been reproduced in black and white.
- This document is paginated as submitted by the original source.
- Portions of this document are not fully legible due to the historical nature of some of the material. However, it is the best reproduction available from the original submission.

**NASA TECHNICAL
MEMORANDUM**

NASA TM-78888

NASA TM-78888

**ION BEAM SPUTTER ETCHING AND DEPOSITIGN
OF FLUOROPOLYMERS**

by Bruce A. Banks, James S. Sovey,
Thomas B. Miller, and Karen S. Crandall
Lewis Research Center
Cleveland, Ohio 44135

TECHNICAL PAPER to be presented at the
Eighth International Conference on Electron and
Ion Beam Science and Technology
sponsored by The Electrochemical Society, Inc.
Seattle, Washington, May 21-26, 1978



ION BEAM SPUTTER ETCHING AND DEPOSITION OF FLUOROPOLYMERS

by Bruce A. Banks, James S. Sovey,
Thomas B. Miller and Karen S. Crandall

National Aeronautics and Space Administration
Lewis Research Center
Cleveland, Ohio 44135

ABSTRACT

Fluoropolymer etching and deposition techniques including thermal evaporation, rf sputtering, plasma polymerization, and ion beam sputtering are reviewed. Etching and deposition mechanisms and material characteristics are discussed. Ion beam sputter etch rates for polytetrafluoroethylene (PTFE) were determined as a function of ion energy, current density and ion beam power density. Peel strengths were measured for epoxy bonds to various ion beam sputtered fluoropolymers. Coefficients of static and dynamic friction were measured for fluoropolymers deposited from ion bombarded PTFE.

INTRODUCTION

The etching and deposition of fluoropolymers is of significant industrial interest. Stringent application requirements concerning friction, adhesion, dielectric properties, hydrophobicity, chemical inertness, and high temperature survivability have fostered the widespread utilization of fluoropolymers. Similarly, there are many applications in which a thin coating or adhesively bonded fluoropolymer laminate would be of great utility.

This paper presents a review of fluoropolymer vacuum etching and deposition technology followed by an experimental investigation of the ion beam sputter etch rate of polytetrafluoroethylene. Characteristics of sputter etched and deposited fluoropolymers that may be pertinent to potential applications will also be discussed.

REVIEW OF FLUOROPOLYMER VACUUM ETCHING AND DEPOSITION TECHNOLOGY

Heating of polytetrafluoroethylene (PTFE) and fluorinated ethylene propylene (FEP) sufficient to cause thermal evaporation will also cause thermal decomposition involving formation of free radicals due to random polymer chain scission (ref. 1). However both fluoropolymers leave a carbon residue and in the case of PTFE

the largest scission fragment was C_3F_8 (which represented only 2.5 percent of the decomposition fragments). The results of several investigators indicate that thermal decomposition of PTFE in the range 360° to 600° C results in C_2F_4 as the primary product (ref. 2).

Mathias and Miller (ref. 2) have performed rf decomposition of PTFE at 11.5 torr resulting in a similar distribution of reaction products (0.37 percent CF_4 , 6.43 percent C_2F_6 , 85.22 percent C_2F_4 , 5.90 percent C_3F_8 , 2.08 percent C_3F_8). A yellow polymer and free carbon were found to deposit when helium was used as a carrier gas. The deposit was 23.2 percent soluble in carbon tetrachloride. When oxygen was used as a carrier gas the deposit was white and absent of free carbon. Other researchers have performed rf sputtering of PTFE with inert gases resulting in deposition of yellow colored films (refs. 3, 4, and 5). In all cases the deposition occurs in the presence of total pressures $\geq 2 \times 10^{-3}$ torr. At these pressures, where mean free paths are shorter than 2.5 cm, and at reasonable target-substrate separations there is reasonable probability of further fragmentation within the discharge plasma. Mathias and Miller found (at 11.5 torr) that the main gaseous product, C_2F_4 , is a result of the combination of CF_2 radicals. The high ion and electron arrival rates at the deposition sites can allow further molecular damage and polymer crosslinking. Radiofrequency (rf) sputtered PTFE films are harder than commercial bulk PTFE (refs. 3 and 4). Crosslinking would tend to increase polymer hardness. Commercial PTFE is quasi-crystalline as opposed to amorphous rf sputtered films (refs. 8). Harrop et al. (ref. 3) report that rf sputtered PTFE films are stable to at least 100° C hotter than commercial PTFE.

Plasma polymerization has also been used to deposit fluorocarbon films by introducing CF_4 (ref. 6) or C_2F_4 (ref. 7) into an rf discharge. The mechanism for thin film polymerization as described by Hollahan (ref. 7) involves adsorption of monomers on the substrate surface followed by intermediate radical and monomer ion formation as a result of the plasma's ion, electron, neutral and photon bombardment. The surface species continually react to grow polymer chains with extensive crosslinking and unsaturation resulting in high mechanical strength fluoropolymer films. Holland (ref. 6) reports that the plasma polymerized fluorocarbon films are colorless and much harder than rf sputtered films. Fluorine deficiency in the form of free or incompletely bonded carbon can cause strong adsorption of blue light resulting in the film appearing yellow when viewed in white light.

Ion beam and rf sputter etching of PTFE and FEP have resulted in similar target surface morphologies but the deposited films have different properties (refs. 8 and 9). Table I summarizes the findings of references 1, 3, 4, 5, 6, 7, 8 and 10 and compares reported properties of commercial, thermally evaporated, rf sputtered, plasma polymerized and ion beam sputter deposited fluoropolymers.

The films in table I are produced from PTFE targets or its gaseous monomers. The most significant differences between ion beam and rf sputter deposited fluoropolymer films are the lower deposition pressure and quasi-crystalline structure of the ion beam deposited films. The low pressure environment of ion beam deposition would substantially reduce ion and/or plasma interactions at the deposition surfaces. These reduced interactions would significantly reduce the rate of polymer formation by intermediate radical and monomer ion formation of adsorbed monomers which occur with rf and plasma polymerization. However the ion beam deposition rates are of the same order of magnitude as rf and plasma polymerization rates. One might thus conclude that a possible mechanism for ion beam fluoropolymer deposition would involve the sputter removal of a wider molecular weight distribution of polymer scission fragments, ions, radicals that deposit and/or react at the substrate surface without requiring further plasma interaction. The low pressure environment may allow large scission fragments to escape from the target to the substrate without further scission as can occur with rf sputtering.

Two unique characteristics of sputter etching fluoropolymers are the extremely high sputter etch rates and the resulting large cone or grasslike surface microstructures. Hall and Green (ref. 9) and Rost (ref. 8) measured the sputter etch rates of FEP and PTFE respectively and found them to be approximately two orders of magnitude higher than those of metals and glass ($\sim 10^2$ CF₂ groups per incident ion) Rost et al. (ref. 8) attributes the higher sputter etch rates of PTFE to breakup of strong bonds in molecular chains producing a wide distribution of scission fragments that leave the target surface by thermal effects where only small intermolecular forces must be overcome.

Hall and Green also measured erosion rates of similar linear addition polymers (polyvinylfluoride and linear polypropylene) but did not observe elevated erosion rates. More rapid crosslinking than depolymerization was felt to cause this result. The FEP ion beam sputter yields measured by Hall and Green also exhibit a significant sensitivity to ion current density. This is also a unique characteristic in that most materials have sputter yields nearly independent of current density provided the sputter removal rate is sufficient to maintain a clean target surface which is reasonably free from adsorbed environmental gases (refs. 11 to 13).

The large cone or grasslike surface microstructures resulting from ion bombardment of fluoropolymers have been observed for FEP and PTFE (refs. 9 and 14). Both ion beam sputtering and rf sputtering of PTFE produce grasslike surface structures with diameters of a few microns and lengths up to more than 100 μ m. Rost et al. (ref. 8) found the structures to always be parallel to the direction of the incident ions. He also determined, by X-ray diffraction, that the degree of crystallinity increased as a result of surface structure formation. Morrison and

Robertson (ref. 4) also suggest that the etch pattern reflects the crystallinity of the PTFE and that sputter etching occurs preferentially along grain boundaries and/or interstitial amorphous regions. Rost et al. compared X-ray diffraction analyses of rf and ion beam sputter deposited PTFE films and found that only the ion beam sputter deposited films possessed quasi-crystallinity similar to that of the target material. The rf sputter deposited films were found to be amorphous.

The extremely rough surface morphology of sputter textured fluoropolymers enables strong mechanical attachment to high modulus adhesives. Sputter etched PTFE has demonstrated superior adhesiveness to epoxy resins in comparison to conventional sodium/naphthalene treated PTFE (refs. 14 and 15).

APPARATUS AND PROCEDURE

Two different electron bombardment ion sources and vacuum facilities were used for sputter etching, an 8 cm diameter mercury ion source (figs. 1 and 2) and a 30 cm diameter argon ion source (figs. 3 and 4). Both sources are low cost adaptations of generically similar devices developed for auxiliary and primary electric propulsion in space. Detailed description of the sources can be found in references 16 and 17. A simplified schematic of an electron bombardment ion source is shown in figure 5.

Fluoropolymer targets were placed downstream of the ion sources and on the centerline of the ion beams. Ion incidence was normal to the target surfaces for all the sputter etch rate measurements. The vacuum facility pressures were in the 10^{-5} to 10^{-6} torr range during ion beam sputtering. Figure 6 depicts the target sample holder configuration used for documentation of the ion beam sputter etch rates. Target samples 1- by 2- by 0.16-cm thick of PTFE were placed behind a 0.03 cm thick tantalum shield with a 0.5- by 0.5-cm square opening to control the area of ion impingement on the PTFE target. Ion beam sputter etch rates were calculated from measured PTFE weight loss per unit area and sputtering duration. Micrometer thickness loss measurements were also used to confirm the weight loss data. PTFE ion beam sputter etch rate dependence upon ion beam current density, ion energy, and power density was determined. Biased planar probe measurements of the ion beam current density at the location of the target and ion source net accelerating voltage were used to ascertain ion beam current, energy, and power densities.

Target sample holders, which were used to determine target temperatures or to etch strips of fluoropolymers (2.5- by 15-cm by 1.6-3 mm thick) for subsequent peel testing, had minimal or no metal covering the sample at the ion impingement surface. Preliminary peel tests were performed using TRA-CAST BB-3103 epoxy resin manufactured by TRACON, Inc. to bond the fluoropolymer strips to

bead blasted thick copper plates. Sputter deposition of PTFE was performed by the 30 cm argon ion source with nonnormal ion incidence on the target (fig. 7). The PTFE sputter products were deposited on window glass plates which were then used for coefficient of friction measurements. The friction measurements were made by sliding samples of polished type 303 stainless steel down the inclined fluoropolymer coated glass plates.

RESULTS AND DISCUSSION

Ion Beam Sputter Etch Rates of Fluoropolymers

The ion beam sputter etch rate of PTFE, as a function of argon and mercury ion energy, is shown in figure 8. The data is based on a PTFE density of 2.2 g/cm^3 . Figure 8 indicates that doubling the ion energy from 500 to 1000 eV approximately triples the etch rate for both mercury and argon ions. This is significantly different than most metals where doubling the ion energy from 500 to 100 eV less than doubles the sputtering yield (refs. 18 and 19). One would also expect the sputter yield for high energy ions at high current densities to be independent of current density if PTFE sputtered typical of most materials. Figure 9 is a plot of the sputter yield expressed in equivalent CF_2 groups ejected per incident ion for both argon and mercury ions. At any energy for both mercury and argon ions, increasing the current density substantially increases the sputter yield. Because of the similar behavior of sputter yield (or etch rate) on both ion energy and current density a plot of PTFE etch rate was made as a function of ion beam power density (at the location of the PTFE target). As can be seen in figure 10 nearly all the etch rate data appears to fall on one curve of ion beam power density which shows significantly less dependence on ion energy, current density and ion species. The equation of the straight line plotted through the data is

$$S = 6.17 \times 10^{-2} P^{1.4}$$

where

S = PTFE sputter etch rate in $\mu\text{m/hr}$

P = ion beam power density in mW/cm^2

ORIGINAL PAGE IS
OF POOR QUALITY

The fact that the sputter rate is approximately dependent upon the power density to the 1.4 power allows significant sputtering rate increases to be realized with modest increases in ion beam power density.

The strong power dependence of the sputter etch rate may also imply that the process is dependent on heating by the ion beam. PTFE target temperatures,

measured by implanting 0.125 mm diam Chromel-Alumel wires and the thermocouple junction within a 1.6 mm thick PTFE target, indicated bulk temperatures of only 64° C for 750 eV mercury ions at 0.66 mA/cm² current density. However, stainless steel targets produced temperatures of 208° C when bombarded with mercury ions of the same energy at 0.57 mA/cm² current density. This result seems to suggest that sputter mechanism consumes a significant fraction of the incident ion energy by an ablativelike process. However, the cooling process was not sufficient to prevent bulk thermal damage to PTFE when very high power densities were used. Weissmantel et al. (ref. 20) suggest that the high PTFE sputter rate may be related to molecular agitation due to normal thermal vibration and phonons connected with ion impact shock waves. Sputter etch rates of PTFE may possess temperature dependences that could give further insight as to the detailed mechanisms involved.

Other fluoropolymers that exhibited similarly high sputter etch rates are FEP Teflon^R and PFA Teflon^R. Weigand (ref. 21) in an effort to find other high sputter etch rate polymers has discovered that polyoxymethylene exhibits a high etch rate also producing a rough microstructure surface.

Peel Tests of Adhesively Bonded Ion Beam Etched Fluoropolymers

Ion beam sputter etching was used to produce surface textures on PTFE, FEP, Tefzel^R, and PFA Teflon^R. Figures 11(a) to (d) are scanning electron microscope photographs of these respective surface textures. Table II compares peel strengths of TRA CON, Inc. TRA-CAST BB-3103 epoxy bonds to these fluoropolymers after ion beam texturing with results of bonding with the same epoxy after sodium/naphthalene (Matheson's Poly Etch) surface treatment. Although ion beam texturing can produce a high peel strength bond surface for PTFE, mechanical failure of the peel samples prevented clear comparison with sodium/naphthalene treatment. However ion beam sputtering was an improvement over sodium/naphthalene only for FEP, Tefzel^R, and PFA Teflon^R. The peel strengths measured appear consistent with the observed surface textures if one assumes a predominantly mechanical bond to the surface microstructures.

Fluoropolymers Deposited from Ion Beam Sputtered PTFE

Fluoropolymers films approximately 1.5 μm thick deposited on glass by ion beam sputtering of PTFE were used to evaluate static and dynamic coefficients of friction. The resulting coefficients of friction between the fluoropolymer deposit and polished type 303 stainless steel are

$$\mu_{\text{static}} = 0.34$$

$$\mu_{\text{dynamic}} = 0.16$$

The coefficient of static friction is approximately 3 to 10 times higher than that of commercial PTFE. However, the coefficient of dynamic friction is in reasonable agreement with measurements by Harrop and Harrop (ref. 3) for rf sputtered films and quite close to that of commercial PTFE (see table D). The ion beam deposited films were transparent and had large water contact angles similar to those of commercial PTFE.

SUMMARY

Researchers have etched PTFE by various techniques including thermal evaporation, rf sputtering and ion beam sputtering. These processes and plasma polymerization have been used to deposit fluoropolymer films. Fluoropolymers such as PTFE, FEP and PFA Teflon^R exhibit sputter etch rates significantly higher than most other materials. PTFE has been ion beam sputter etched at rates between 3 and 1740 $\mu\text{m/hr}$ depending on the sputtering conditions. The rate of PTFE ion beam etching has been shown to depend predominantly upon the ion beam power density.

Ion beam sputtering of PTFE, FEP, Tefzel^R and PFA Teflon^R was compared with sodium/naphthalene surface treatment to evaluate epoxy bond peel strengths. Ion beam sputtering was found to produce stronger bonds in all cases except for PTFE. However, ion beam sputtering produced high peel strengths ($>150 \text{ N/cm}$) for PTFE, FEP and PFA Teflon. Peel strengths appear to be related to the surface microstructures resulting from ion beam sputtering.

Fluoropolymer films deposited by ion beam sputtering of PTFE have a coefficient of dynamic friction in reasonable agreement with rf sputtered films and commercial PTFE.

REFERENCES

1. M. White, Thin Solid Films, 18, 157 (1973).
2. E. Mathias, and Glenn H. Miller, J. Phys. Chem., 71, 2671 (1967).
3. R. Harrop, and P. J. Harrop, Thin Solid Films, 3, 109 (1969).
4. D. T. Morrison, and T. Robertson, Thin Solid Films, 15, 87((1973).
5. I. H. Pratt, and T. C. Lausman, Thin Solid Films, 10, 151 (1972).
6. L. Hollard, H. Biederman, and S. M. Ojha, Thin Film Solids, 35, L19 (1976).

**ORIGINAL PAGE IS
OF POOR QUALITY**

$$\mu_{\text{static}} = 0.34$$

$$\mu_{\text{dynamic}} = 0.16$$

The coefficient of static friction is approximately 3 to 10 times higher than that of commercial PTFE. However, the coefficient of dynamic friction is in reasonable agreement with measurements by Harrop and Harrop (ref. 3) for rf sputtered films and quite close to that of commercial PTFE (see table I). The ion beam deposited films were transparent and had large water contact angles similar to those of commercial PTFE.

SUMMARY

Researchers have etched PTFE by various techniques including thermal evaporation, rf sputtering and ion beam sputtering. These processes and plasma polymerization have been used to deposit fluoropolymer films. Fluoropolymers such as PTFE, FEP and PFA Teflon^R exhibit sputter etch rates significantly higher than most other materials. PTFE has been ion beam sputter etched at rates between 3 and 1740 $\mu\text{m/hr}$ depending on the sputtering conditions. The rate of PTFE ion beam etching has been shown to depend predominantly upon the ion beam power density.

Ion beam sputtering of PTFE, FEP, Tefzel^R and PFA Teflon^R was compared with sodium/naphthalene surface treatment to evaluate epoxy bond peel strengths. Ion beam sputtering was found to produce stronger bonds in all cases except for PTFE. However, ion beam sputtering produced high peel strengths ($>150 \text{ N/cm}$) for PTFE, FEP and PFA Teflon. Peel strengths appear to be related to the surface microstructures resulting from ion beam sputtering.

Fluoropolymer films deposited by ion beam sputtering of PTFE have a coefficient of dynamic friction in reasonable agreement with rf sputtered films and commercial PTFE.

REFERENCES

ORIGINAL PAGE 16
OF POOR QUALITY

1. M. White, Thin Solid Films, 18, 157 (1973).
2. E. Mathias, and Glenn H. Miller, J. Phys. Chem., 71, 2671 (1967).
3. R. Harrop, and P. J. Harrop, Thin Solid Films, 3, 109 (1969).
4. D. T. Morrison, and T. Robertson, Thin Solid Films, 15, 87((1973).
5. I. H. Pratt, and T. C. Lausman, Thin Solid Films, 10, 151 (1972).
6. L. Holland, H. Biederman, and S. M. Ojha, Thin Film Solids, 35, L19 (1976).

7. J. R. Hollahan, T. Wydeven, and C. C. Johnson, Applied Optics, 13, 1844 (1974).
8. M. Rost, H. J. Erler, H. Giegengack, O. Fiedler, C. Weissmontel, Thin Solid Films, 20, S15 (1974).
9. D. F. Hall, and H. E. Green, "Erosive Chemical Effects of Energetic Mercury Ions Bombarding Spacecraft Surface Material," AIAA Paper No. 72-446, Apr. 1972.
10. W. R. Hudson, and R. R. Robson, "Ion Beam Technology and Applications," NASA TM X-3517, May 1977.
11. G. K. Wehner, Phys. Rev., 102, 650 (1956).
12. P. K. Rol, J. M. Fluit, and J. Kistemaker, Physica, 26, 1000 (1960).
13. N. Laegreid, and G. K. Wehner, J. Appl. Phys., 32, 365 (1961).
14. T. Moriuchi, S. Yamamoto, M. Ezoe, H. Tabata, K. Uemori, F. Shigeta, Y. Ohya, A. Tsumuro, and J. Nakai, "Surface Properties of Sputter Etched Fluoropolymers," 7th Intern. Vac. Congr. and 3rd Intern. Conf. Solid Surfaces, Vienna, 1977, p. 1501.
15. J. Nakai and K. Fukunaga, "Process for Surface Treating Molded Articles of Fluorine Resins," U. S. Patent No. 4,064,030, Dec. 20, 1977.
16. "8-cm Mercury Ion Thruster System Technology," AIAA Paper 74-1116, Oct. 1974.
17. J. S. Sovey, "A 30-cm Diameter Argon Ion Source," NASA TM X-73509, 1976.
18. G. Carter, and J. S. Colligon, Ion Bombardment of Solids, Heinemann Educational, London, 1968.
19. C. H. Weijnsfeld. A. Hoogendoorn, and M. Koedam, Physica, 27, 763 (1961).
20. C. Weismantel, M. Rost, O. Fiedler, H. J. Erler, H. Giegengack, and J. Horn, "Interaction of Ion Beams with Polymer Surfaces Leading to Etching and Sputtering Processes," Proc. 6th Internl. Vacuum Congr. 1974, p. 439; Jap. J. Appl. Phys., Suppl. 2, Pt. 1, VI (1974).
21. A. J. Weigand, "The Use of An Ion-Beam Source to Alter the Surface Morphology of Biological Implant Materials," NASA TM-78851, 1978.

TABLE I. - DEPOSITED FLUOROPOLYMER FILMS

	Commercial PTFE	Thermally evaporated	rf sputtered	Plasma polymerized	Ion beam sputtered
Deposition conditions					
Target material	-----	PTFE	PTFE	-----	PTFE
Pressure, torr	-----	-----	$10^{-3} - 10^{-2}$	0.1 - 1.2	$10^{-5} - 8 \times 10^{-4}$
Environmental gas	-----	-----	Argon or PTFE decomposition gases	CF_4 and C_2F_4	Argon, xenon and krypton
Rate, Å/sec	-----	-----	0.8 - 17.2	1.2 - 8	4.2
Deposited film properties					
Structure	Quasi-crystalline	-----	Amorphous	-----	Quasi-crystalline
Color	White	-----	Yellow	Clear	Clear
Microindentation hardness (V. P. N.)	5	-----	12.5	-----	-----
Coefficient of dynamic friction	0.09 - 0.15	-----	0.08 - 0.14	-----	-----
Dielectric constant	2.2	2.0 - 3.6	1.5 - 3	-----	1.4 - 6.8
Resistivity, Ω -cm	$10^{17} - 10^{21}$	-----	$3 \times 10^{16} - 7 \times 10^{18}$	-----	1×10^{12}
Dielectric strength, V/m	$1.5 \times 10^7 - 10^8$	10^7	$4 \times 10^8 - > 7 \times 10^8$	-----	10^8
Dissipation factor ($\tan \delta$, 1 kHz)	$2 \times 10^{-5} - 1 \times 10^{-4}$	2×10^{-2}	$1 \times 10^{-3} - 6 \times 10^{-3}$	-----	$2 \times 10^{-3} - 8 \times 10^{-3}$
Maximum tolerable temperature, °C	300	-----	450	-----	-----

TABLE II. - FLUOROPOLYMER PEEL STRENGTHS

	Ion beam textured					Sodium/Naphthalene Treated		
	Sputter duration, min	Argon ion energy, eV	Current density, mA/cm ²	Peel strength		Treatment duration, min	Peel strength	
				N/cm	lb/in		N/cm	lb/in
PTFE	30	750	0.6	>166*	>95*	5	>224*	>128*
FEP	30	750	.6	270*	>154*	1	30	17
Tefzel ^R	70	750	.3	30	17	5	5.1	2.9
PFA Teflon ^R	70	750	.3	150	86	5	<1.8	<1

*Maximum peel strength could not be measured because tensile failure of peel test polymer.

ORIGINAL PAGE IS
OF POOR QUALITY

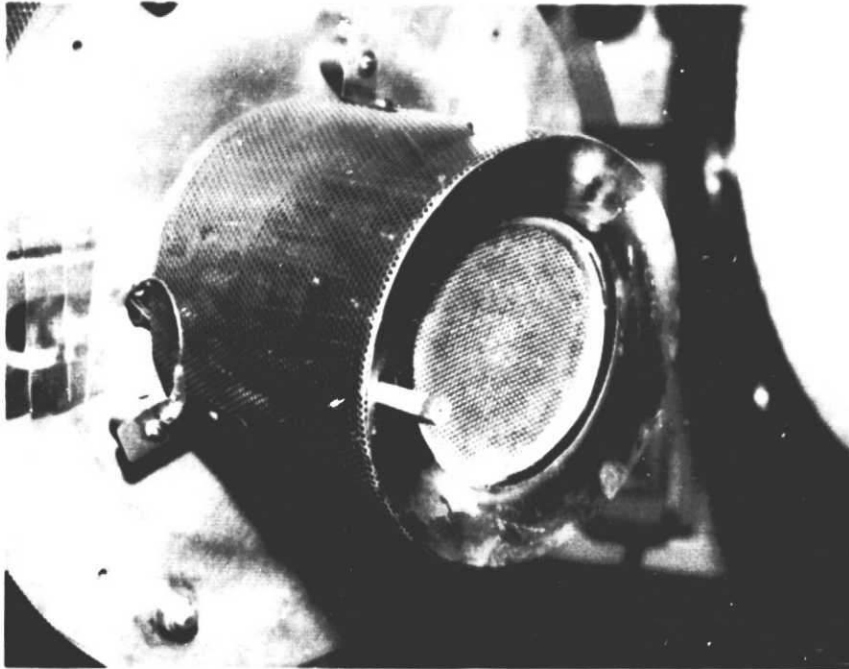

Figure 1. - 8 Cm diameter mercury ion source.

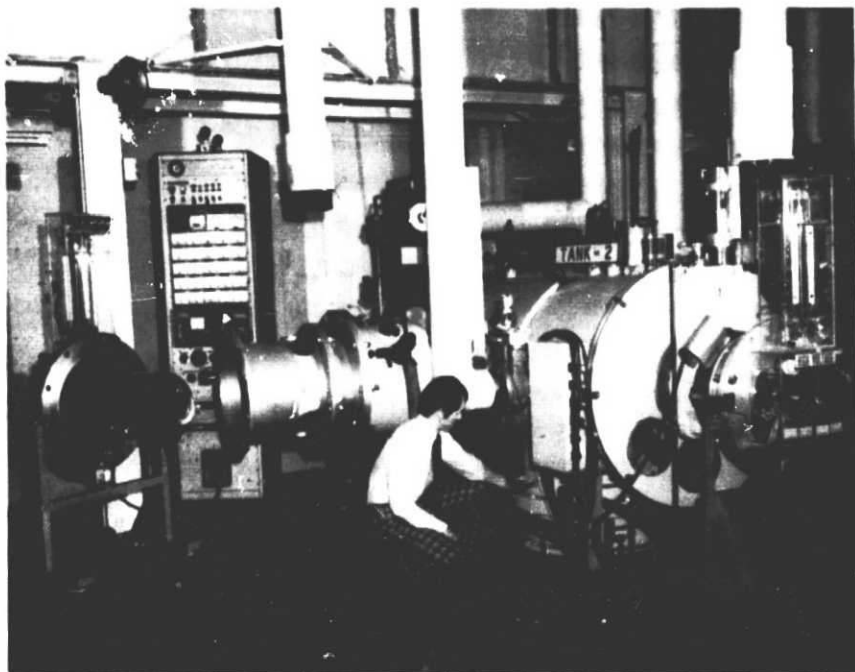

Figure 2. - 8 Cm mercury ion source with it's vacuum facility and power supplies.

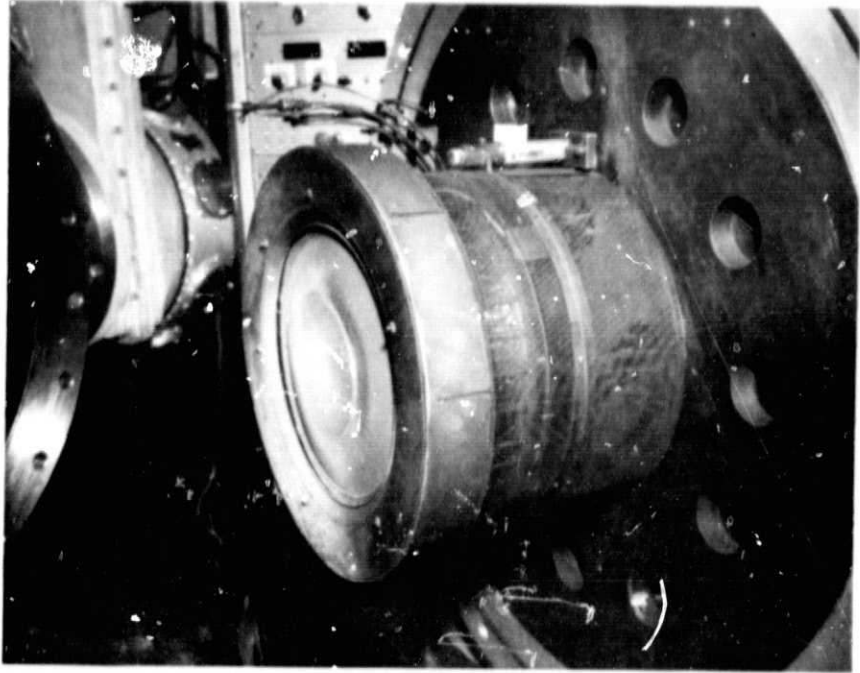

Figure 3. - 30 Cm diameter argon ion source.

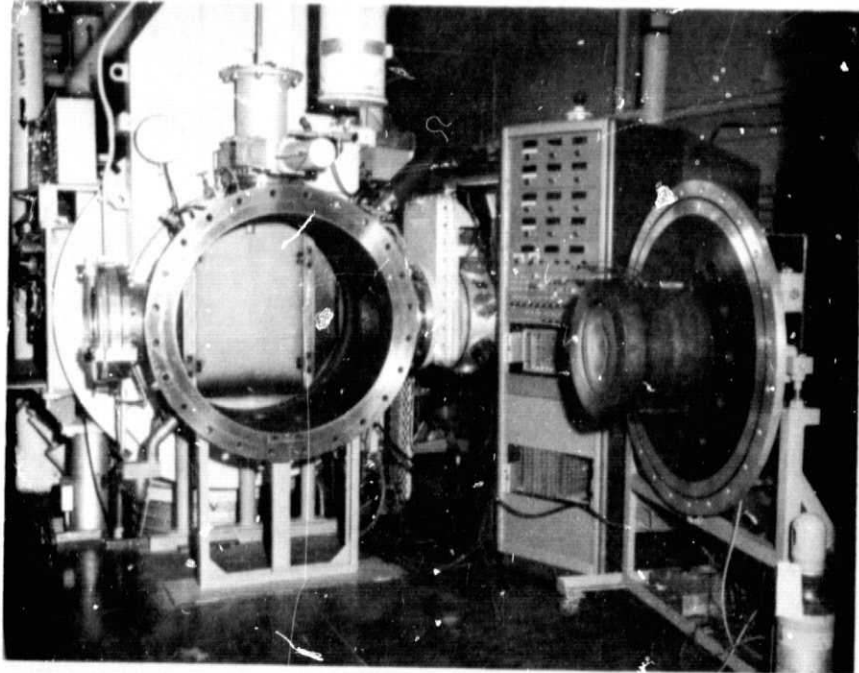

Figure 4. - 30 Cm argon ion source with it's vacuum facility and power control console.

**ORIGINAL PAGE IS
OF POOR QUALITY**

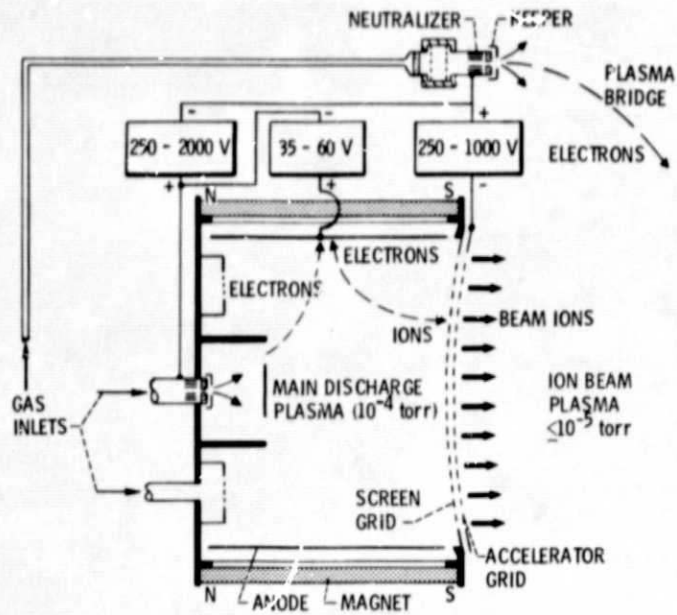

Figure 5. - Basic schematic for electron bombardment ion source.

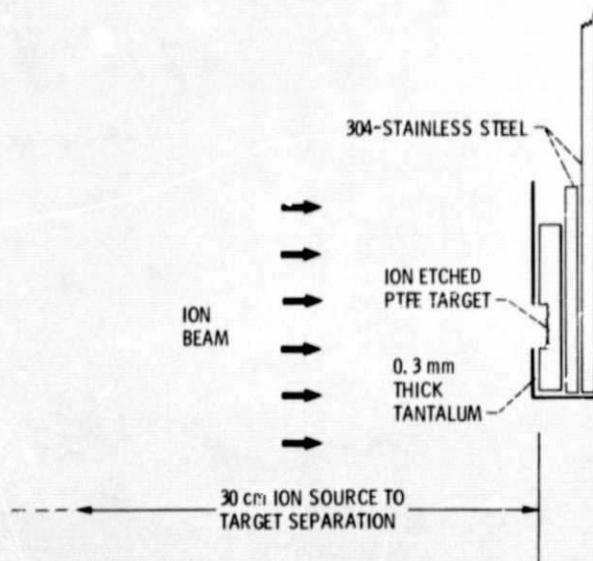

Figure 6. - Target sample holder for sputter rate documentation.

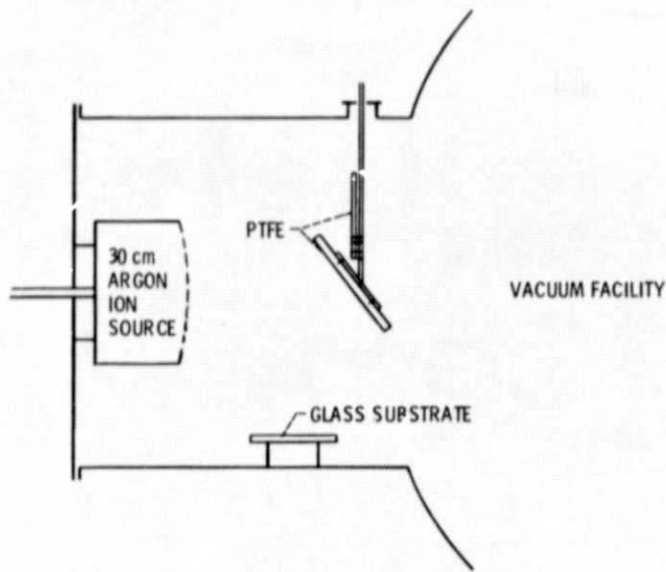

Figure 7. - Deposition configuration for fluoropolymer coating of glass.

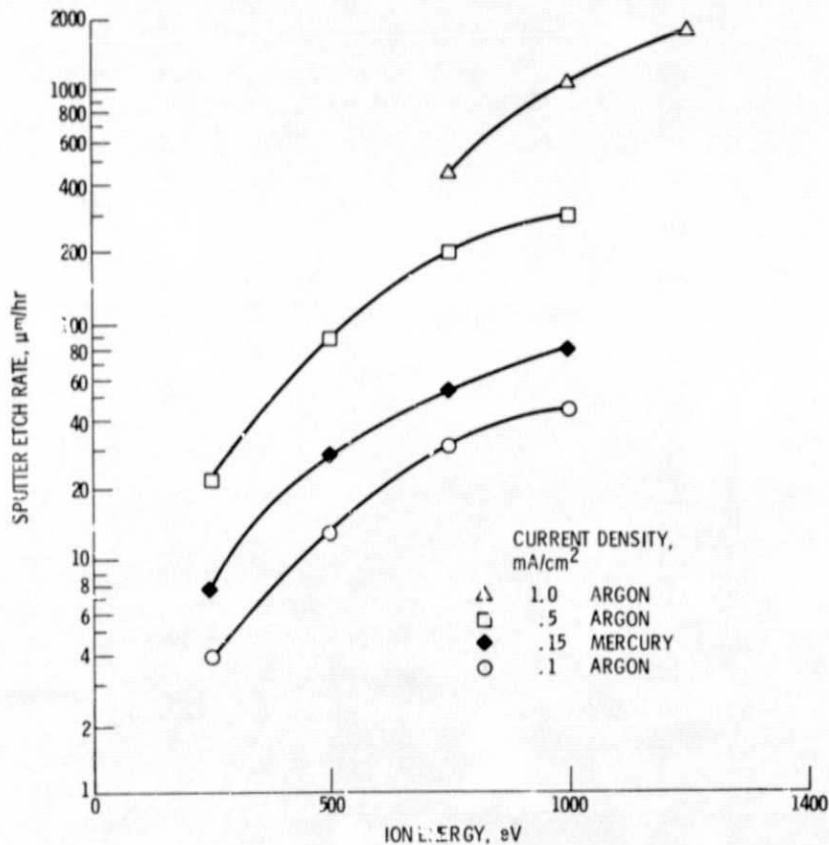

Figure 8. - Ion beam sputter etch rate of PTFE as a function of argon and mercury ion energy.

ORIGINAL PAGE IS
OF POOR QUALITY

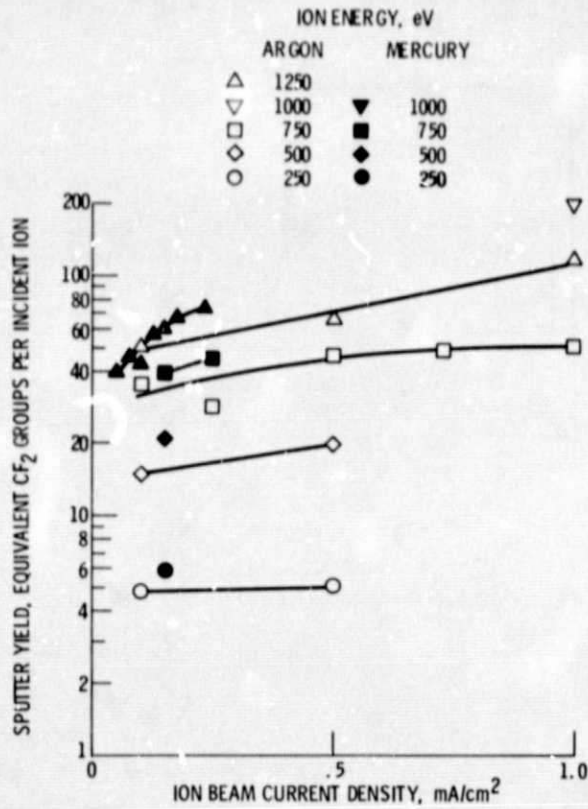

Figure 9. - Sputter yield of PTFE as a function of argon and mercury ion current density.

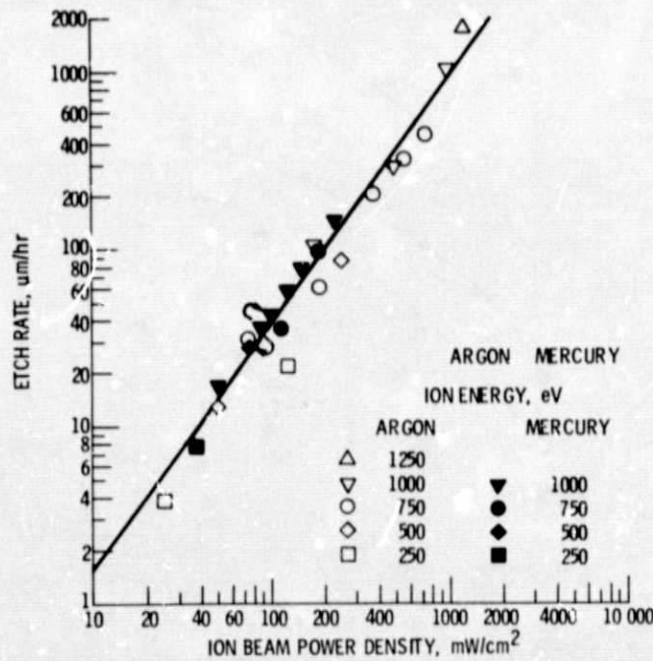

Figure 10. - PTFE etch rate as a function of ion beam power density for argon and mercury ions.



(a) PTFE SPUTTER ETCHED 0.5 HOUR BY 750 eV ARGON IONS AT 0.6 mA/cm².



(b) FEP SPUTTER ETCHED 0.5 HOUR BY 750 eV ARGON IONS AT 0.6 mA/cm².

Figure 11. - Ion beam textured fluoropolymers.

ORIGINAL PAGE IS
OF POOR QUALITY



(c) TEFZEL^R SPUTTER ETCHED 1.2 HOURS BY 750 eV ARGON IONS AT 0.3 mA/cm².



(d) PFA TEFLON^R SPUTTER ETCHED 1.2 HOURS BY 750 eV ARGON IONS AT 0.3 mA/cm².

Figure 11. - Concluded.