

Lawrence Berkeley National Laboratory

Recent Work

Title

ION SOURCE FOR THE PRODUCTION OF MULTIPLY CHARGED HEAVY IONS

Permalink

<https://escholarship.org/uc/item/9c25870z>

Authors

Anderson, Carl E.
Ehlers, Kenneth W.

Publication Date

1955-12-19

UNIVERSITY OF
CALIFORNIA

*Radiation
Laboratory*

ION SOURCE FOR THE PRODUCTION
OF MULTIPLY CHARGED HEAVY IONS

TWO-WEEK LOAN COPY

*This is a Library Circulating Copy
which may be borrowed for two weeks.
For a personal retention copy, call
Tech. Info. Division, Ext. 5545*

DISCLAIMER

This document was prepared as an account of work sponsored by the United States Government. While this document is believed to contain correct information, neither the United States Government nor any agency thereof, nor the Regents of the University of California, nor any of their employees, makes any warranty, express or implied, or assumes any legal responsibility for the accuracy, completeness, or usefulness of any information, apparatus, product, or process disclosed, or represents that its use would not infringe privately owned rights. Reference herein to any specific commercial product, process, or service by its trade name, trademark, manufacturer, or otherwise, does not necessarily constitute or imply its endorsement, recommendation, or favoring by the United States Government or any agency thereof, or the Regents of the University of California. The views and opinions of authors expressed herein do not necessarily state or reflect those of the United States Government or any agency thereof or the Regents of the University of California.

UNIVERSITY OF CALIFORNIA

Radiation Laboratory
Berkeley, California

Contract No. W-7405-eng-48

ION SOURCE FOR THE PRODUCTION OF
MULTIPLY CHARGED HEAVY IONS

Carl E. Anderson

Sloane Physics Laboratory, Yale University, New Haven, Conn.

and

Kenneth W. Ehlers

University of California Radiation Laboratory, Berkeley, Calif.

December 19, 1955

ION SOURCE FOR THE PRODUCTION OF
MULTIPLY CHARGED HEAVY IONS

Carl E. Anderson

Sloane Physics Laboratory, Yale University, New Haven, Conn.

and

Kenneth W. Ehlers

University of California Radiation Laboratory, Berkeley, Calif.

December 19, 1955

ABSTRACT

A pulsed, cold-cathode ion source has been developed to produce multiply charged ions for use in a linear accelerator. Milliampere currents of such ions as He_4^{2+} , C_{12}^{2+} , N_{14}^{3+} , O_{16}^{3+} , Ne_{20}^{3+} and smaller currents of S_{32}^{5+} and A_{40}^{6+} have been produced in focused beams.

Mass spectra of the various ionization states produced by the arc are presented. Constructional details of the source and the associated electronic equipment are given, and operating characteristics of the source and ion extraction are discussed.

ION SOURCE FOR THE PRODUCTION OF MULTIPLY CHARGED HEAVY IONS

Carl E. Anderson

Sloane Physics Laboratory, Yale University, New Haven, Conn.

and

Kenneth W. Ehlers

University of California Radiation Laboratory, Berkeley, Calif.

December 19, 1955

INTRODUCTION

Recently, interest has developed in experiments in nuclear physics and chemistry that require the production of high-energy beams of heavy ions. At present, heavy ions are being accelerated in cyclotrons at Oak Ridge,¹ Berkeley,² Birmingham,³ and Stockholm.⁴ To obtain high-energy particles these accelerators require ions that are multiply charged. At Oak Ridge, triply charged ions of nitrogen are produced in the ion source and then accelerated. In the other cyclotrons, the multiply charged ions are produced by stripping ions of lower charge near the center of the machine.

The construction of linear accelerators at Berkeley and Yale University to produce high-energy beams of heavy ions necessitated the study of an ion source that would be suitable in an injector for these machines. These "linacs" were designed to accept ions with an energy of 0.07 Mev per nucleon, and having a charge-to-mass ratio (N_e/A) of approximately 0.15 up to the mass of argon. They further require that the ion beam consist of 2-millisecond pulses with a repetition rate of 10 pulses per second (duty factor = 2%). The injection method is to accelerate ions approximately 500 kv with a Cockcroft-Walton voltage multiplier from a suitable ion source located in its high-voltage terminal.

This method of injection places restrictions upon the ion source. First, since it must be located in the high-voltage terminal of the Cockcroft-Walton device, the size, weight, and power requirements must be kept to a minimum. Second, as the accelerator column can handle only limited currents, in the order of 1 milliamper, before space-charge forces cause serious beam spreading, only ions of the desired N_e/A should be admitted. This necessitates magnetic analysis of the charge states produced by the source before the beam is presented to the column.

The first restriction seems most easily satisfied by using a pulsed cold-cathode discharge (PIG type) as a source of the multiply charged ions. This eliminates the need for hot cathodes and the large associated filament power equipment. It also reduces the arc power requirements to the duty factor (0.02), which further reduces the need for heat insulation and additional cooling equipment. The cathode life, as well, is increased by the duty cycle.

The work of Jones and Zucker⁵ has shown that a PIG type ion source would produce the desired charge states of nitrogen, when operated continuously. Information was not available, however, relative to the operation of a pulsed cold-cathode source in which thermionic emission from the cathodes does not occur.

Since the probability of ionization reaches a broad maximum at about five or more times the ionization potential of the charge state required, it is evident that a high-voltage arc is desirable. Such arcs are more easily obtained by using cold cathodes, where electron emission is produced by positive-ion bombardment rather than by hot filaments.

In an arc of this type, the two cathodes are electrically connected and are pulsed negative with respect to the anode. Initially, electrons present in the gas or produced by the application of voltage are accelerated into the arc chamber and reflected by the opposing electrode. Positive ions produced by these oscillating electrons strike the cathodes and release secondary electrons, which, confined by a magnetic field, are returned to regenerate the cycle. This action produces a very intense arc plasma from which ions can be extracted.

TEST ARRANGEMENT

The analysis of the products of the ion source was carried out in 180° mass spectrometer arrangement. The magnetic field was obtained from an available 20-inch-diameter magnet having a 10-in. gap with a maximum field of 4500 gauss. The vacuum chamber was pumped by a 14-in. oil diffusion pump with a -40°F baffle and liquid nitrogen thimble traps. The base pressure was about 10^{-6} mm of Hg.

The ion beams were collected on a traveling Faraday cup or observed on a fluorescent screen. The collected pulsed ion-current wave forms were observed and measured with an oscilloscope.

The general layout is shown in Fig. 1. The present arc structure is shown in Fig. 2. The anode is made of carbon, the cathodes of tantalum, and the insulators of unfired lavite. The cathodes are mounted on a water-cooled copper support and the gas is fed into the carbon anode through a stainless steel tube. Both the copper support and the gas-feed tube serve also as electrical connections to the arc. The arc assembly of the type used is shown in detail in Fig. 3. The arrangement allows for movement of the arc support structure to align the axis of the arc with the magnetic field. The rate of gas flow is controlled by a medical oxygen needle valve. The extracting electrode is made of highly polished stainless steel mounted on an adjusting support. Controls outside the vacuum chamber move the extractor both parallel and perpendicular to the arc face.

A block diagram of the pulsed arc power supply and associated electronic equipment is shown in Fig. 4. The pulse line has a characteristic impedance of 1000 ohms and is charged by a variable negative 10-kv supply. The modulator provides a 2-msec voltage pulse to the arc cathodes. The negative 5-kv supply is included to maintain a low current discharge which facilitates striking the pulsed arc. The series resistor and the potential divider monitor the

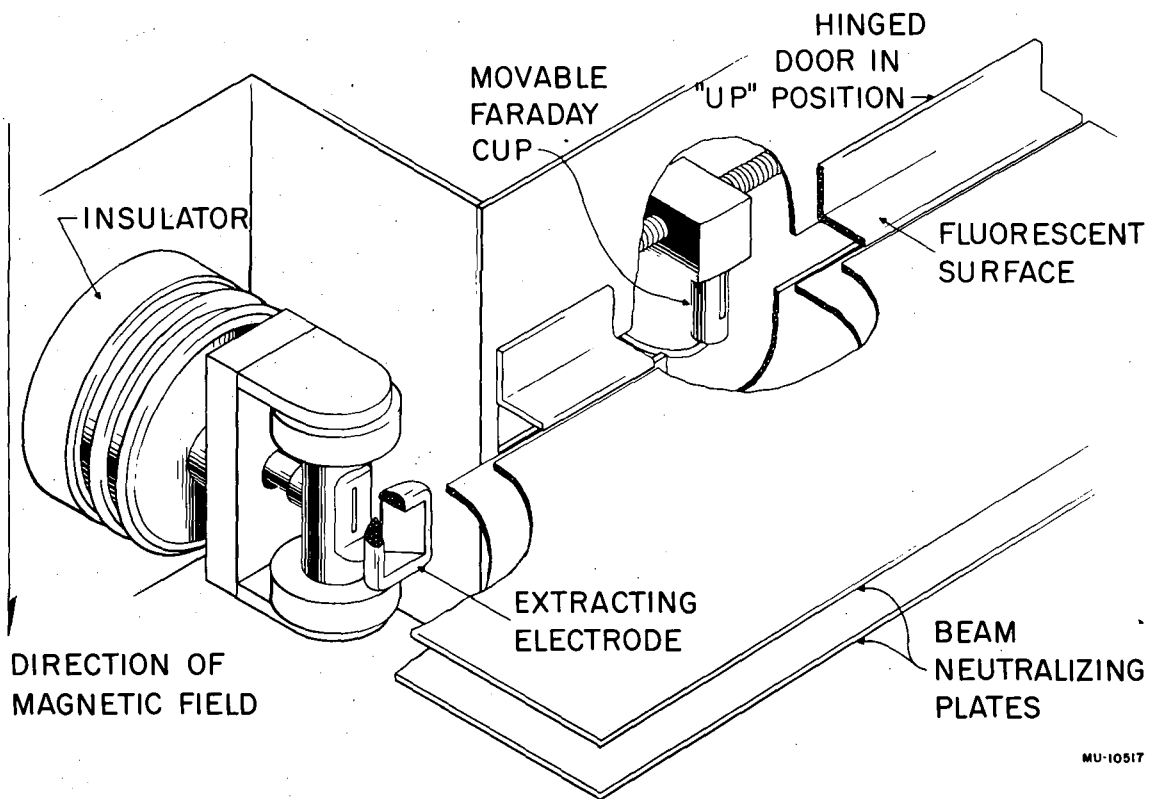
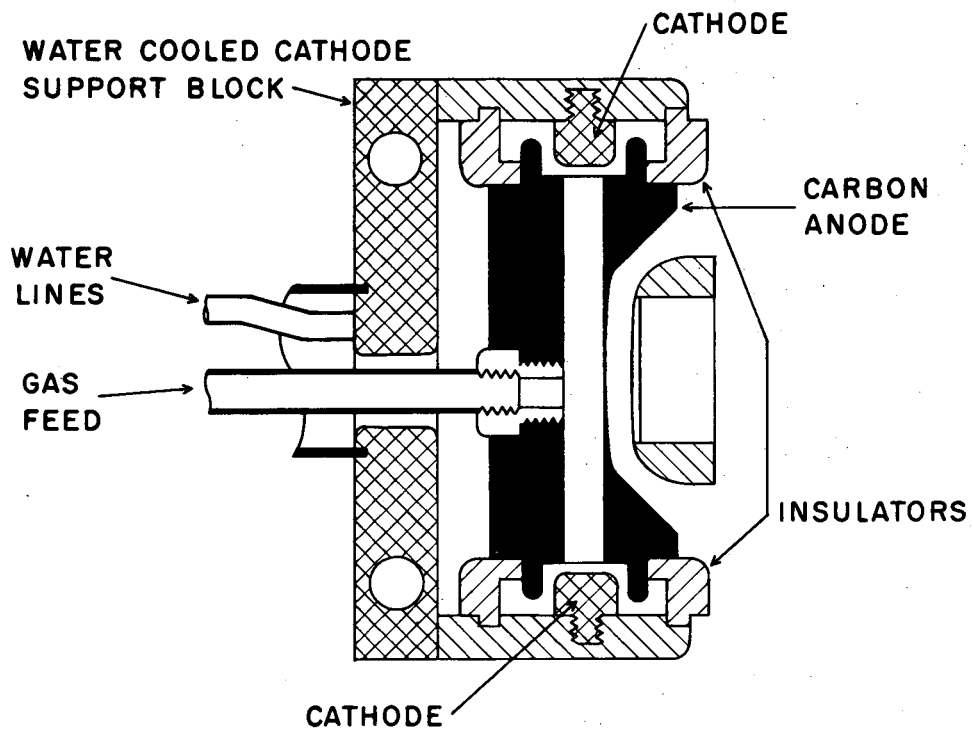

Fig. 1. General Layout

MU-10517



MU-10518

Fig. 2. Arc Structure

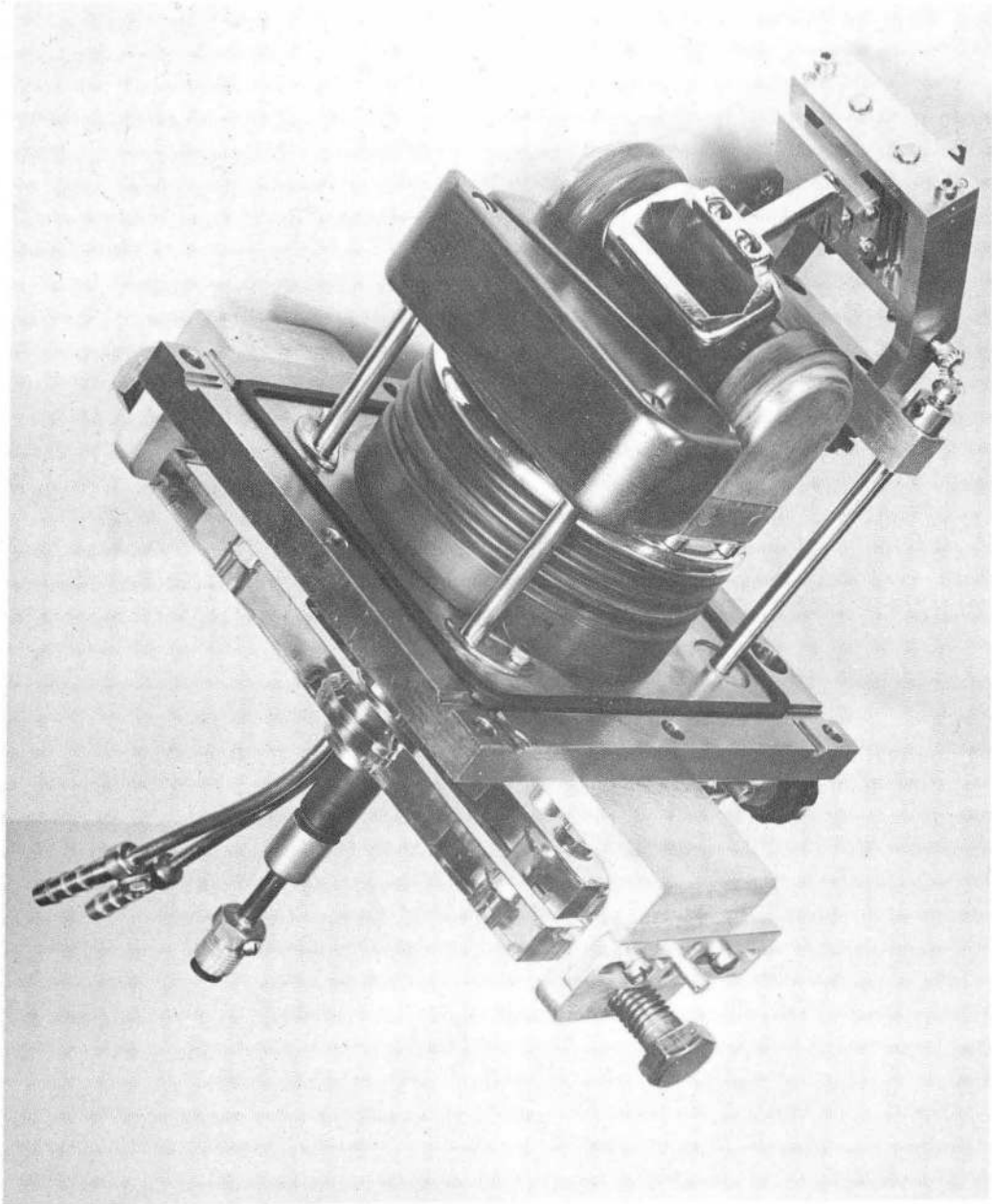

ZN-1414

Fig. 3. Arc Assembly

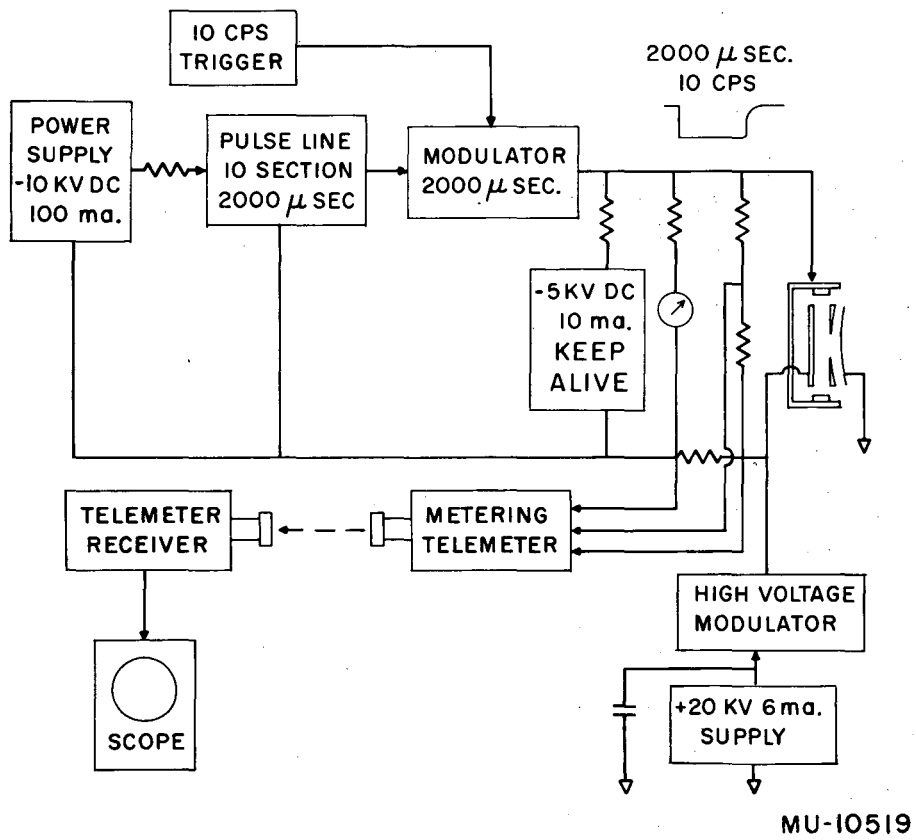

Fig. 4. Block Diagram

arc operation. The arc and its power equipment is raised to the desired accelerating potential by means of a pulsed positive variable 20-kv supply. The ac power for the arc equipment is fed through isolation transformers. The monitoring signals are telemetered to the oscilloscope at ground potential.

Power for the pulsed arc can be obtained either from a capacitor or from a pulse line. Despite the simplicity of using a capacitor, a prohibitive size is required to prevent a large voltage drop during the pulse. A suitable pulse line, which would deliver most of its stored energy in each pulse, is concluded to be more desirable. Initial arc operation indicated that the impedance of the arc was about 1000 ohms. To match this and also obtain a low-voltage ripple on the pulse a 10-section 1000-ohm, 2-millisecond pulse line was built.

A small inductor was added to the line to improve the arc current and voltage wave forms. Under matched conditions the line would be charged to twice the pulsed voltage of the load.

Varying arc parameters, such as type of gas, gas pressure, and cathode material, change the arc impedance. To eliminate the "ring down" that would occur, a hard tube modulator is incorporated. In this modulator circuit, a trigger from a separate chassis is converted to a positive gate of controlled width and is then fed to the grid of a 304TH tube. This tube therefore acts as a switch.

CATHODE MATERIALS

The cathodes, including the mounting thread, are machined from 3/8-in. tantalum rod. These disks (3/8 in. by 3/16 in.) are screwed firmly into the cathode support blocks; they are easily removed and replaced.

The life of these tantalum cathodes, under pulsed operating conditions with nitrogen gas, is approximately 80 hours. During this time, a hemispherical depression of about 1/8 in. radius is eroded into the cathode surface (Fig. 5).

Best results are obtained from the use of a cathode material that provides a stable high-voltage high-current arc. A typical curve of arc current vs arc voltage for tantalum is shown in Fig. 6.

A search was made to find a more satisfactory cathode material. Parameters of interest were arc stability, arc voltage, arc current, and the wear or sputtering rate. The results divided the materials tested into two main groups. One group, consisting of magnesium, aluminum, titanium, and zirconium, yielded good arc currents and low wear rates, but were characterized by very unstable operation. The other group, consisting of tantalum, molybdenum, nickel, tungsten, niobium, and copper (2% Be) exhibited higher wear rates and lower arc currents, but were much more stable in their operation. Of this group tantalum was selected as being the best.

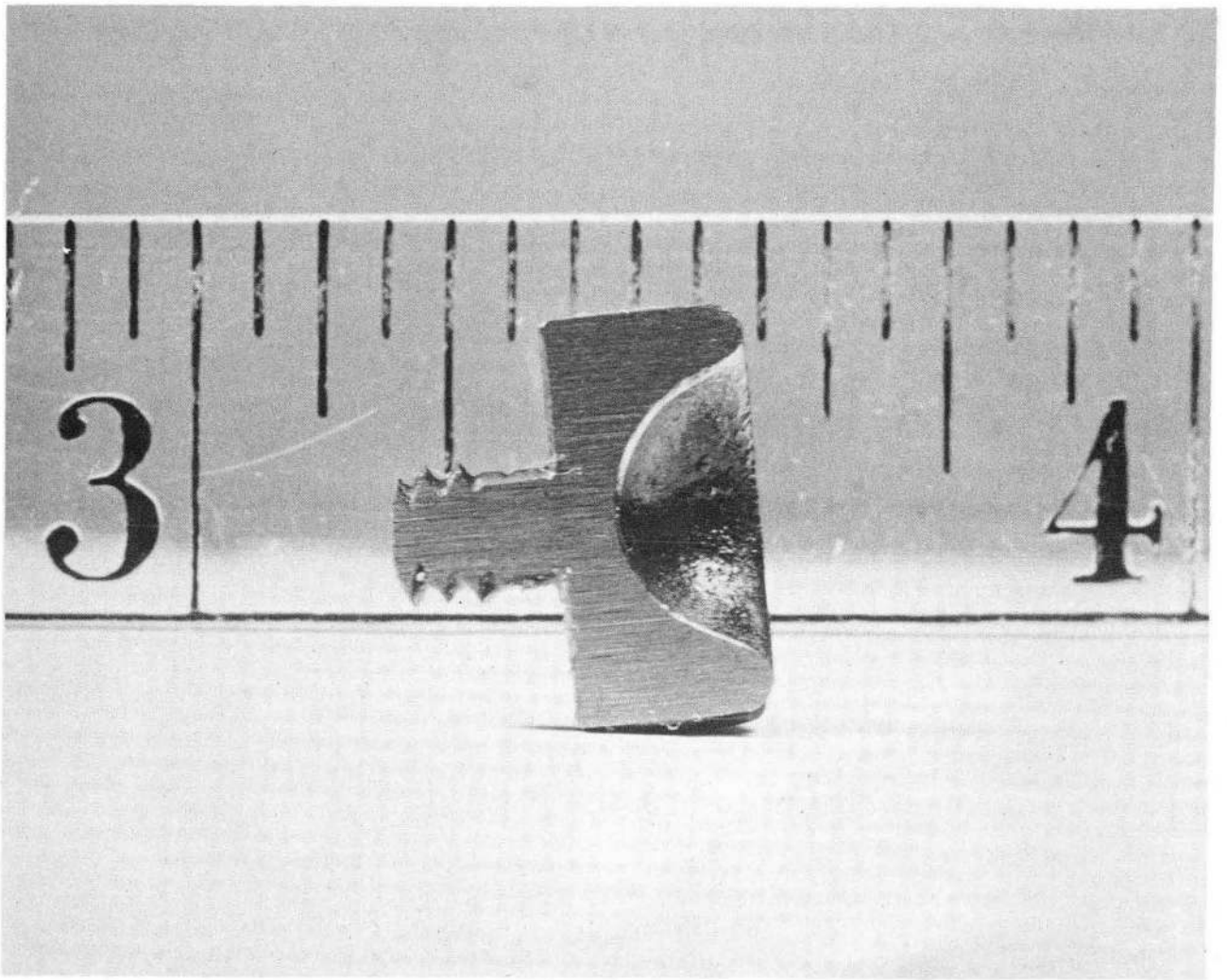

ZN-1413

Fig. 5. Cathode

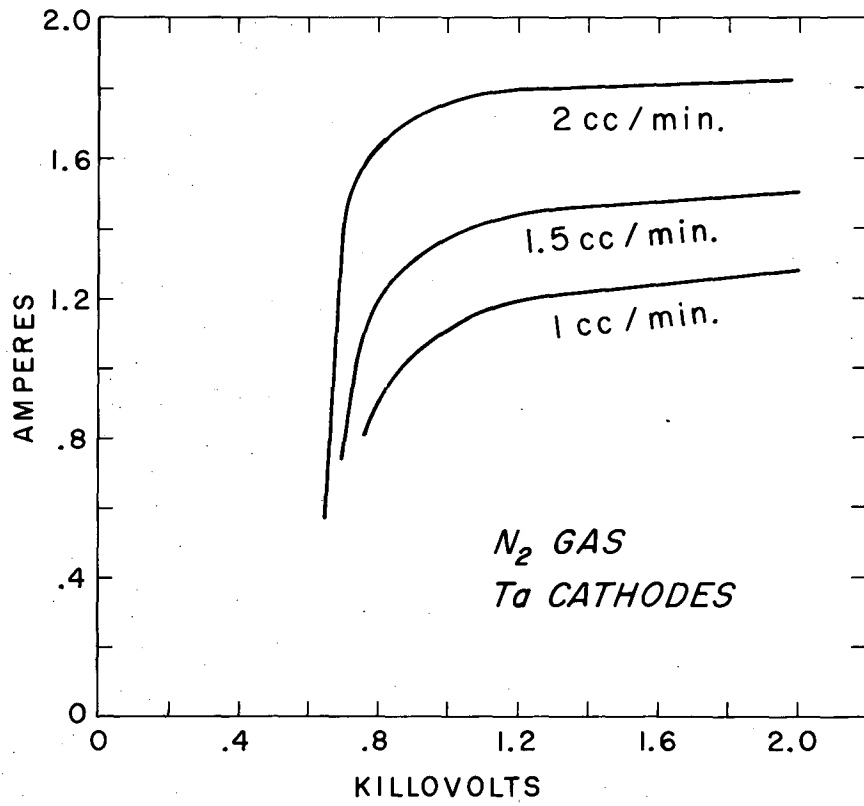

MU-10520

Fig. 6. Characteristic Curve

The advantages of higher arc currents and longer cathode life offered by the first group are certainly worth obtaining, and this group requires further investigation.

The primary cause of the observed arc instability is due to what is generally termed "cathode spots". This effect (a severe breakdown to a low-voltage condition) appears to be due to the presence of oxides of these metals on the cathode surface. More stable arcs, although still unsatisfactory, have been obtained by using one cathode of this first group and one of tantalum. Arc currents approaching twice that obtained from tantalum alone have been measured when using a combination of titanium and tantalum. These higher-current arcs not only yield greater total ion currents, but also increase the relative proportions of the higher charged states.

The observed wear rates of the various materials are in accordance with the vacuum sputtering theory of Keywell⁶ using the sputtering threshold data of Wehner.⁷

ARC ANODE DESIGN

Carbon was chosen as the anode material, as it requires no cooling and is easily machined. The length of the arc represents a compromise. A long arc allows a longer extraction slit, which increases the ion-emitting area; however, it also requires a larger magnet and magnetic gap. As a magnet with a 4-in. gap had been chosen for the final operating heavy-ion source, this work was limited to anode geometries that would accord with this dimension. This allowed an anode arc column length of 2.25 in. (Fig. 2). An arc column 1/4 in. in diameter and an ion exit slit 3/4 in. by 1/16 in. were used.

The cathodes were essentially recessed by an annular ring of carbon to prevent the sputtered material from the cathode from coating the insulators and shorting the arc. This sputtered material does coat the walls and top of the arc-defining column, which reduces the diameter of the arc column and builds up to narrow the gap between the arc electrodes. Thus, the anode must be periodically removed for cleaning; the period is approximately equal to that of cathode replacement.

Upon occasion, it was found that the sputtered layer of cathode material would not stick to the anode, but would spall off to short out the arc either temporarily or permanently. This was particularly true of anodes fabricated of aluminum, stainless steel, and some of the coarser grades of carbon. It was found, however, that C-18, a fine-grain, high-density carbon, was far better in building up a tenacious coating that resists spallation.

The location of the gas-inlet hole was found to be unimportant. No significant differences in arc operation were observed with gas fed in the middle or at the ends; the gas-feed line was located solely in terms of mounting convenience.

EFFECT OF ARC PRESSURE

The operating pressure in the arc was calculated from the gas flow rate. For nitrogen arcs the operating pressure is a few microns. Comparison of the ion spectra obtained at different arc pressures shows that the relative proportion of the high-charge states increases rapidly as the pressure is reduced. Further work would be required to determine exactly the pressure dependence of the ion spectra; however, crude measurements indicate that the ratio of a multiply charged state to the singly charged state increases faster than the inverse first-power law in the pressure region observed. Most efficient production of high-charge states is therefore obtained at the lowest operating pressure.

Mention was previously made of the effect of a low-current dc discharge in facilitating the striking of the pulsed arc. This discharge produces an additional effect in that it acts as an ion pump. In this way the gas fed into the arc anode is pumped to the ends of the anode between arc pulses. This allows a reduction in the gas flow rate by about a factor of two, depending upon the current in the dc discharge.

In Fig. 7 photographs of typical arc voltage and current wave forms are shown. The voltage wave form is fairly flat over the entire pulse, indicating the adequacy of the ten-section pulse line. The current wave form can be seen to decay slightly in time. This is apparently a gas-pumping effect, as the wave form can be made essentially flat by a slight increase in gas flow.

ARC ALIGNMENT AND OTHER MAGNETIC FIELD EFFECTS

The operation of the arc is found to be extremely sensitive to the alignment of the axis of the arc with the magnetic field. A few degrees of misalignment are sufficient to cause a very hashy arc or one that does not operate for the full pulse length. The effect is even more pronounced at higher magnetic fields. This fact is probably connected with the increase in arc current observed as the magnet field is increased. Data obtained while running nitrogen gas in a separate magnet system have shown that from the minimum operating field of 2000 gauss, below which the arc fails to operate, to the maximum field obtained, 7000 gauss, the arc current increases linearly by about 20%. It has also been observed that the minimum operating field changes with different gases.

HIGH-VOLTAGE HOLDING PROBLEM

One source of considerable difficulty in maintaining the extracting potential is the existence of precessional electrons. These electrons can arise from secondary emission caused by ion bombardment of the extractor. They move in trochoidal paths in the direction of $\underline{E} \times \underline{H}$ and attempt to return to the arc

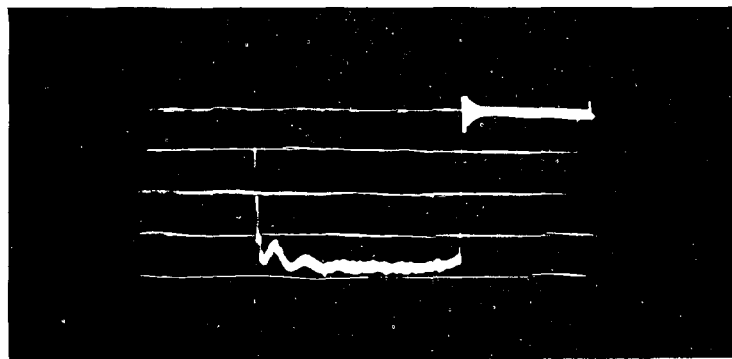

Voltage wave form time base 400μ sec/cm
amplitude 400 v/cm.

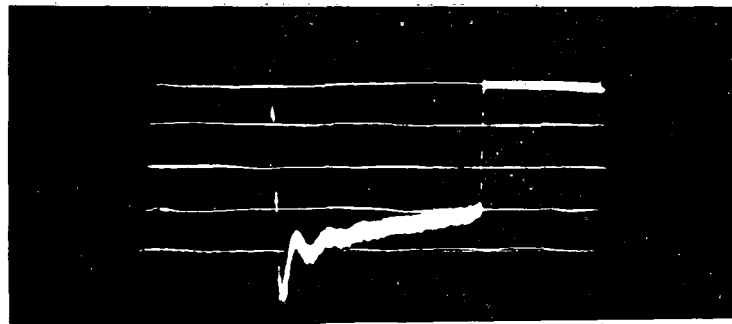

Current wave form Amplitude 0.3 amp/cm.

ZN-1419

Fig. 7. Photographs of voltage and current

potential. In doing so, however, many of them strike the arc-supporting insulator and cause breakdown. This results in a charring of the insulator along its midplane on the side toward which the ion trajectories occur.

This effect can be reduced by increasing the efficiency of the extracting process so that fewer electrons are made, but can be completely eliminated by providing a suitable "dumping" arrangement. By this means the electrons are collected at the potential of the arc before they can reach the insulator. The simplest solution is to create an electric field parallel to the magnetic field. This is done by using carbon blocks inclined to the magnetic field, as shown in Fig. 3. One block is at the arc potential, the other at ground. The electric field between them has a component parallel to the magnetic field which causes the electrons to be collected at the arc potential. After this arrangement was installed no further trouble was experienced from precessional electrons. The gap between the "antitrochoidal" cathode and anode is maintained at 1/8 in.

ION EXTRACTION

The shape of the extracting system significantly affects the efficiency of ion extraction as well as the angular divergence of the beam, because of its focusing action. However, this action depends a great deal on whether or not the ion currents drawn are space-charge limited. Electrode systems with various angles were tested to approximate the Pierce⁸ conditions. The data shown in Fig. 8 were taken with 120° geometry with the extractor anode spacing about 1/8 in. to avoid effects caused by a change of arc current. It is evident that at low voltage most of the ion beam strikes the extracting electrode. Above 5 kv the current to the extractor decreases; its minimum value is at 12 kv. At the same time the collected beam current increases steadily, but finally reaches what seems to be emission limitation. This conclusion is further substantiated in that an increase in the arc current obtained by raising the arc voltage or using different cathodes (like Ti) increases the extracted current. The increase is due not only to an increase in the average charge per ion but also to an increase in the number of singly charged ions. Therefore under the usual operating conditions we have a portion of the atoms in the arc column ionized.

With closer spacing of the anode and extractor or with higher extracting voltage the increased current of ions extracted begins to affect the arc current. This is shown in Fig. 9 by the photographs of the arc current pulse taken without ion extraction and with ions being removed at high voltage. The arc current occasionally decreases by as much as 20%.

Extraction efficiencies are about 90% if calculated from the ratio of collected beam to total current. However, as some of the current drained from the extractor consists of photoelectrons from the extractor, secondary electrons from ions striking the extractor, and collection of ion pairs created in the extractor anode gap, the efficiency should indeed be higher.

The slight curvature of the anode and cathode geometries shown in Fig. 2 provides axial focusing of the extracted beam. The shape of these surfaces was determined empirically and serves to reduce the loss of ions to metal surfaces above and below the beam.

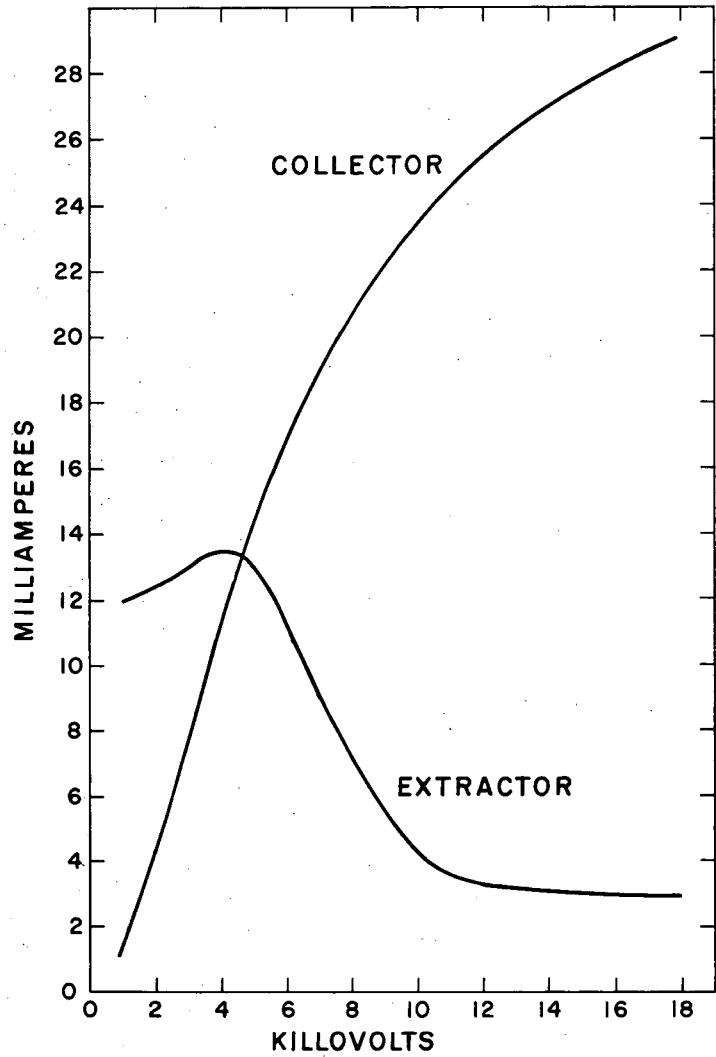

MU-10521

Fig. 8. Chart: Extractor and case readings

Arc current
extractor voltage = 18kv →

Arc current
extractor voltage = 0 →

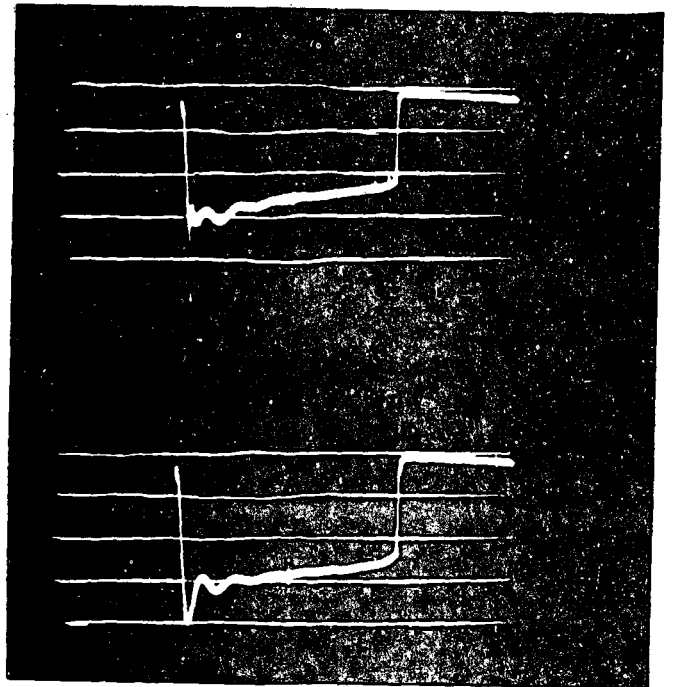

ZN-1420

Fig. 9. Photograph of arc current with extractor

SPACE-CHARGE NEUTRALIZATION

The serious beam spreading caused by the space-charge forces in ion beams of high current density must be overcome in order to obtain ion beams suitable for injection into the Cockcroft-Walton accelerator column. For rectangular beams, where the beam height is much greater than the beam width ($2y$), Thompson and Headrich⁹ and Smith et al.¹⁰ have shown that the beam-spreading curve for a small divergence angle θ is given by

$$y \cong y_0 + Z\theta + \sqrt{m/q} (I/V^{3/2}) \times 10^{10} Z^2, \quad (1)$$

where Z is the distance from the initial aperture y_0 , I is the current per unit slit length, V is the voltage, m the mass of the ion, and q the charge.

As an example, for a slit 2 cm by 0.15 cm, a beam current of 30 ma ($I = 1.5$ a/m) of singly charged nitrogen ions with an initial θ of 0.05 radian, and $V = 15 \times 10^3$ volts,

we have $y = 7.5 \times 10^{-4} + 0.05Z + 3.1Z^2$ in meters.

Therefore at $Z = 1.6$ cm the space-charge term will be equal to the increase due to the initial divergence angle.

To eliminate this spreading, the beam must be completely neutralized by providing the same density of electrons as there is density of ions. With an ion beam of current density J and velocity $v = \sqrt{(2qV)/m}$ the ion density is J/v ions/cc. If the electrons for neutralization are created only by ionization of the residual gas atoms in the vacuum chamber, the rate of production of these electrons will be $J\sigma N$, where σ is the ionization cross section and N is the number of residual gas atoms per cc. Assuming no loss of electrons and immediate removal of the gas ions, the time required to completely neutralize the beam is $\tau = (J/v)/(J\sigma N) = 1/(v\sigma N)$. However, at neutralization, the rate of production of net negative charges must become zero. This implies that as complete neutralization is approached the rate of loss of these electrons to the walls of the chamber or by recombination with the gas ions just balances the rate of production. It is even possible that this balance will occur before the neutralization is complete, resulting in a beam that is still spreading. This effect often occurs in mass spectrometers used for isotope separation, and is usually overcome by increasing the residual gas pressure. In this way the production rate of neutralizing electrons is increased until complete neutralization occurs. The gas pressure necessary for complete neutralization can be reduced to prevent scattering and charge exchange by reducing the rate of loss of the electrons. This effect exists in 180° spectrometers because the motion of the electrons is restricted by the magnetic field. It can also be accomplished by constraining electric fields as has been done by Bernas.¹⁰

Unlike a dc isotope separator, in which the time required to attain complete neutralization is not very important, time is of major concern for pulsed ion beams. In this case neutralization must be reestablished for each ion pulse in a time much shorter than the pulse duration. Further, to prevent scattering

and charge exchange of the multiply charged ion beams, the use of increased residual gas pressure is not desirable. Therefore it is necessary to make efficient use of the electrons created by gas ionization by reducing the rate of loss of these electrons, and--if possible--to create electrons by some other process. The loss rate can be reduced by decreasing the distance between the ion beam and the walls that are perpendicular to the magnetic field. This results in an increase in the electrostatic forces between the ion beam and these surfaces, which increase the rate of removal of gas ions and also acts to prevent the electrons from leaving the beam. In this way the neutralizing time τ will approach that calculated. For example, when we have $\sigma = 10^{-16}$ cm² and use nitrogen gas the characteristic time τ is 40 μ sec at 7.6×10^{-5} mm of Hg and 400 μ sec at 7.6×10^{-6} mm of Hg. To obtain a faster neutralizing time at the lower pressure obviously requires another electron-creating process. This is done by even further decreasing the gap between the bounding surfaces so that some of the ions (particularly before the beam is neutralized) strike the surfaces and produce secondary electrons. To enhance this effect these surfaces were made of aluminum, which has a high ratio of secondary electrons to ions. With this method, neutralization times less than 40 μ sec have been obtained with residual gas pressures as low as 1×10^{-6} mm of Hg.

Figure 10 shows typical collected-ion beams for N_{14}^+ , N_{14}^{2+} , and N_{14}^{3+} . Similar pulse wave forms are obtained with other ion beams.

RESULTS

Spectra of ion output of the arc operation with various gases are presented in Figs. 11 through 18. These spectra were taken at the 180° focal plane by means of a Faraday cup traveling along a 1/4-20 lead screw. The cup's position could be moved through approximately 10 in. and the abscissa for each chart represents turns of the lead screw, 20 divisions representing 1 in. The cup's collimating slit was 0.1 in. wide by 3/4 in. long and the cup was moved one slit width (2 turns) for each reading. The ordinate numbers of beam intensity are relative.

All spectra were taken with the arc operating with 2000- μ sec pulses at 10 per second. The arc ion exit slit was 3/4 by 1/16 in. in all cases. Adjustments were made in the magnetic field and extraction potential so as to include ion charge states with an e/m of approximately 0.15. Tantalum cathodes were used throughout.

Hydrogen

Commercial hydrogen gas (H_2) was used to obtain the spectrum shown in Fig. 11. The arc operated at 2.4 amp and 1750 volts at an indicated vessel pressure of 3.8×10^{-5} mm of Hg.

According to the data of Dushman and Young¹² and Wagener and Johnson¹³ on the sensitivity of standard ion gauges vs various gases, a gas flow rate of approximately 9 cc/min was required. The total integrated current shown is 43.5 ma, with the proton peak representing about 98% of that amount.

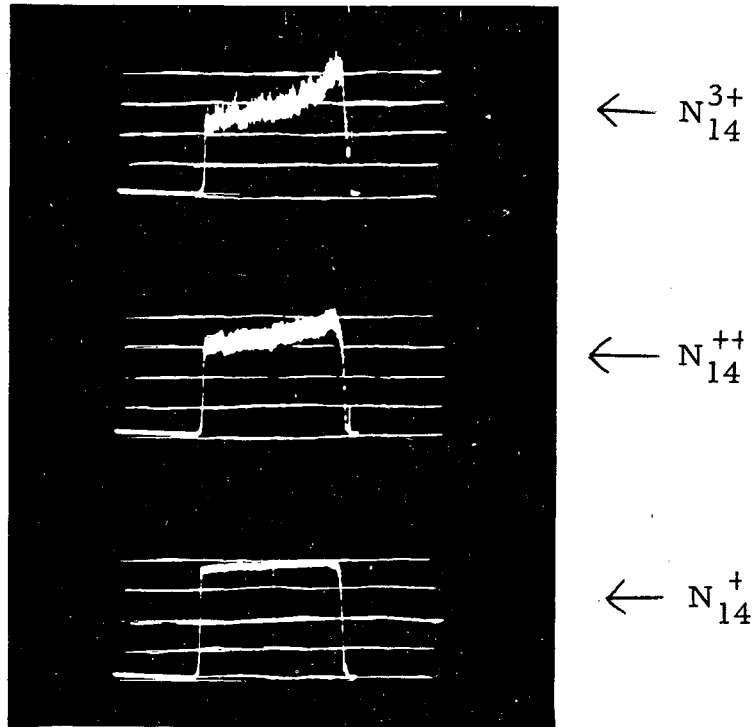

ZN-1421

Fig. 10. Typical Collected Ion Beams

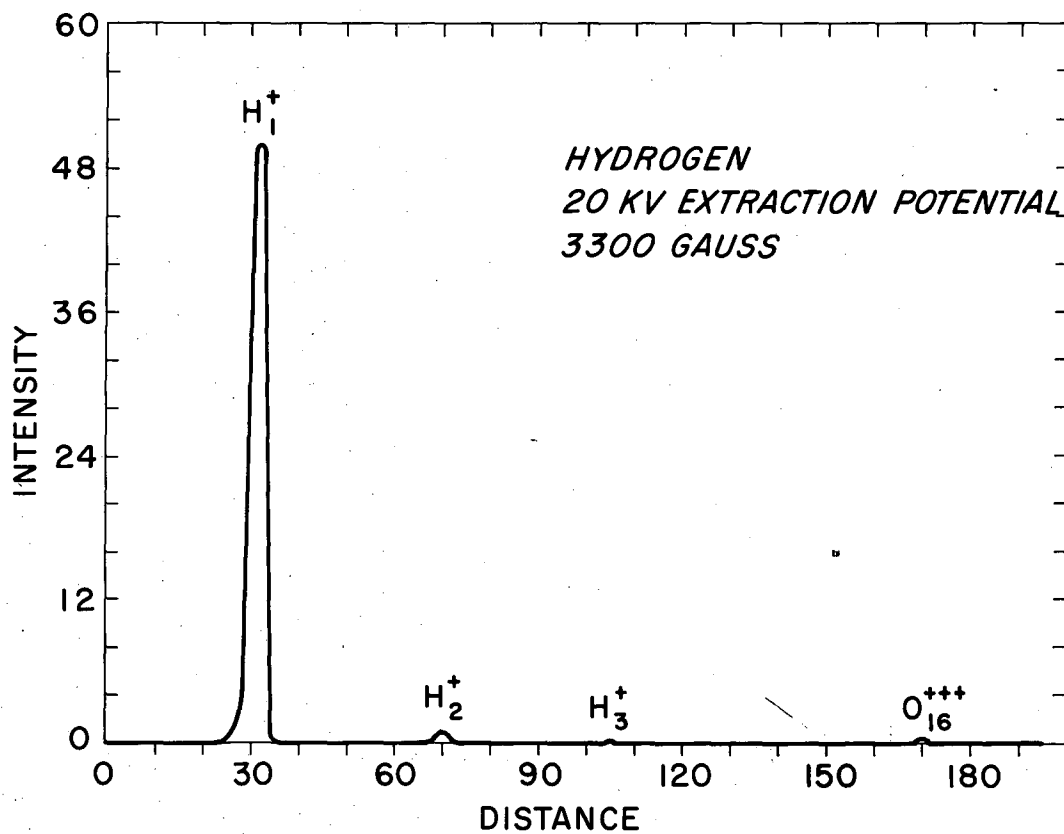

MU-10522

Fig. 11. Hydrogen Spectrum

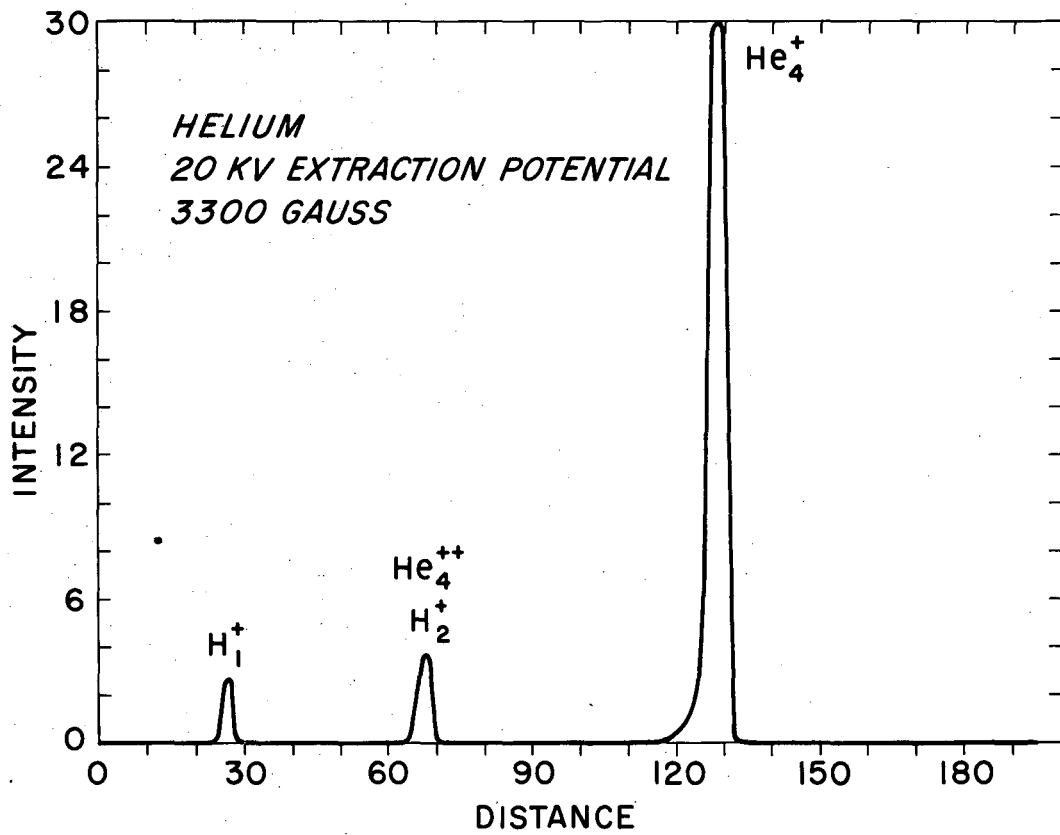

MU-10523

Fig. 12. Helium Spectrum

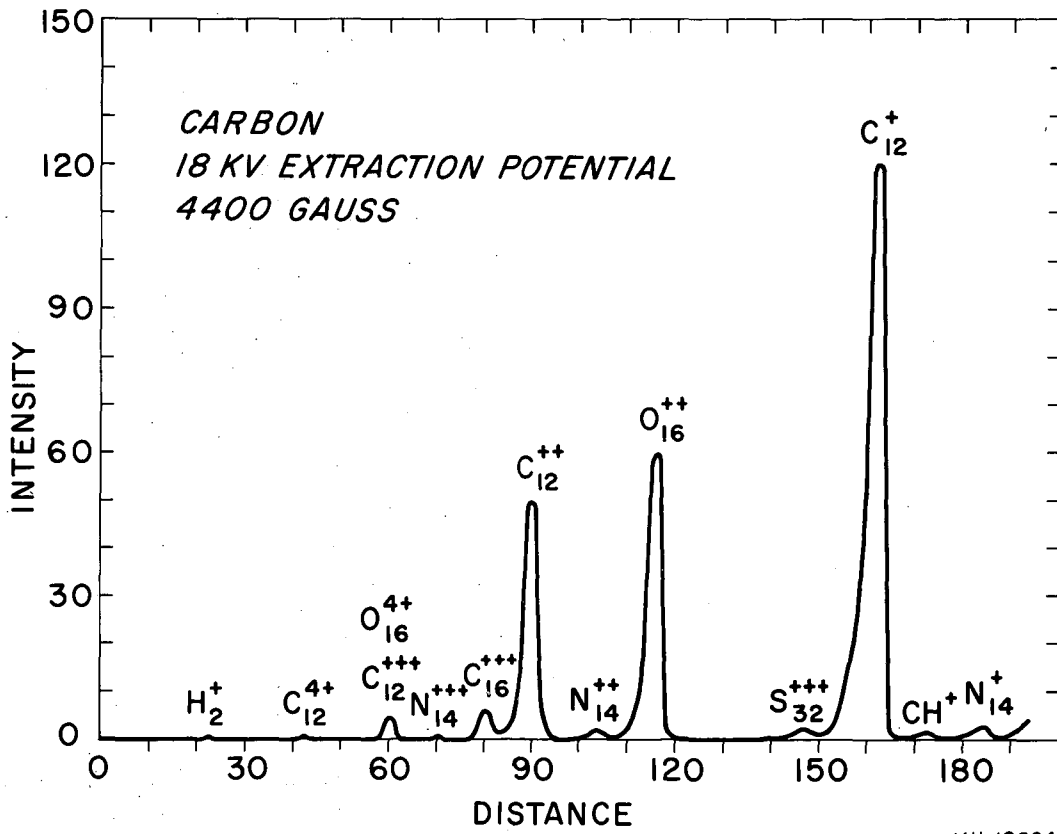

Fig. 13. Carbon Spectrum

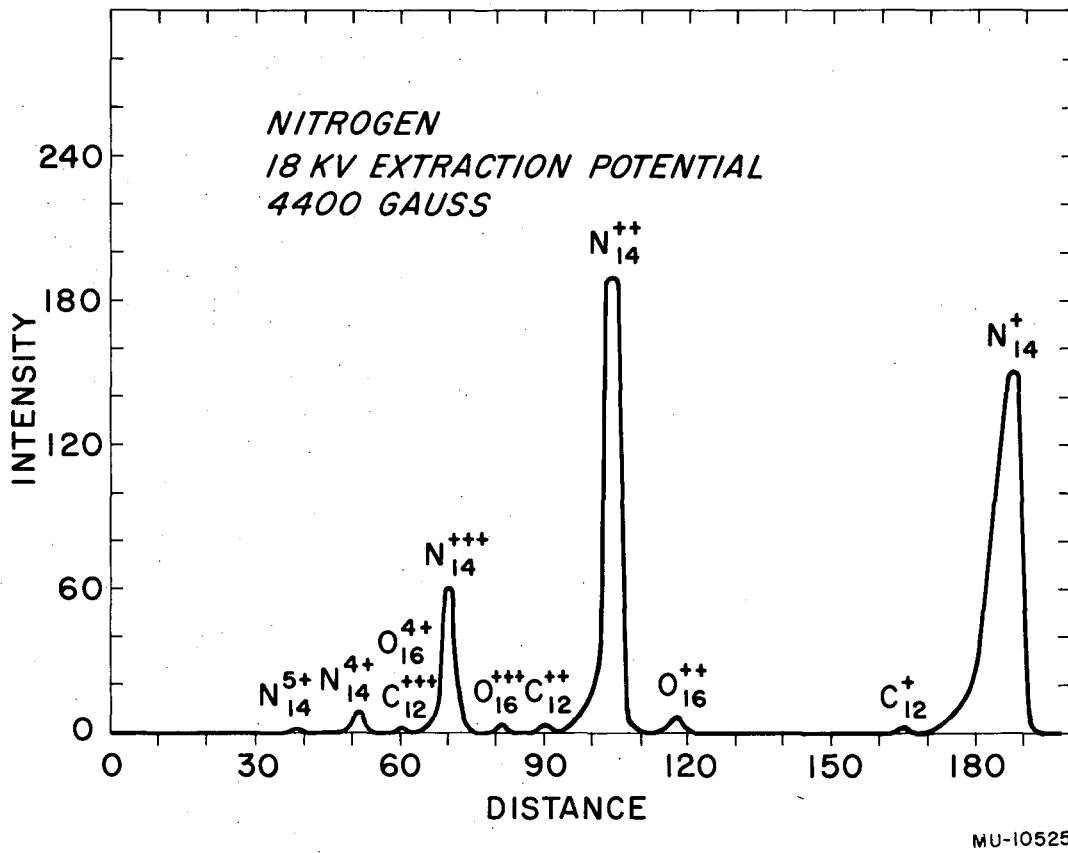
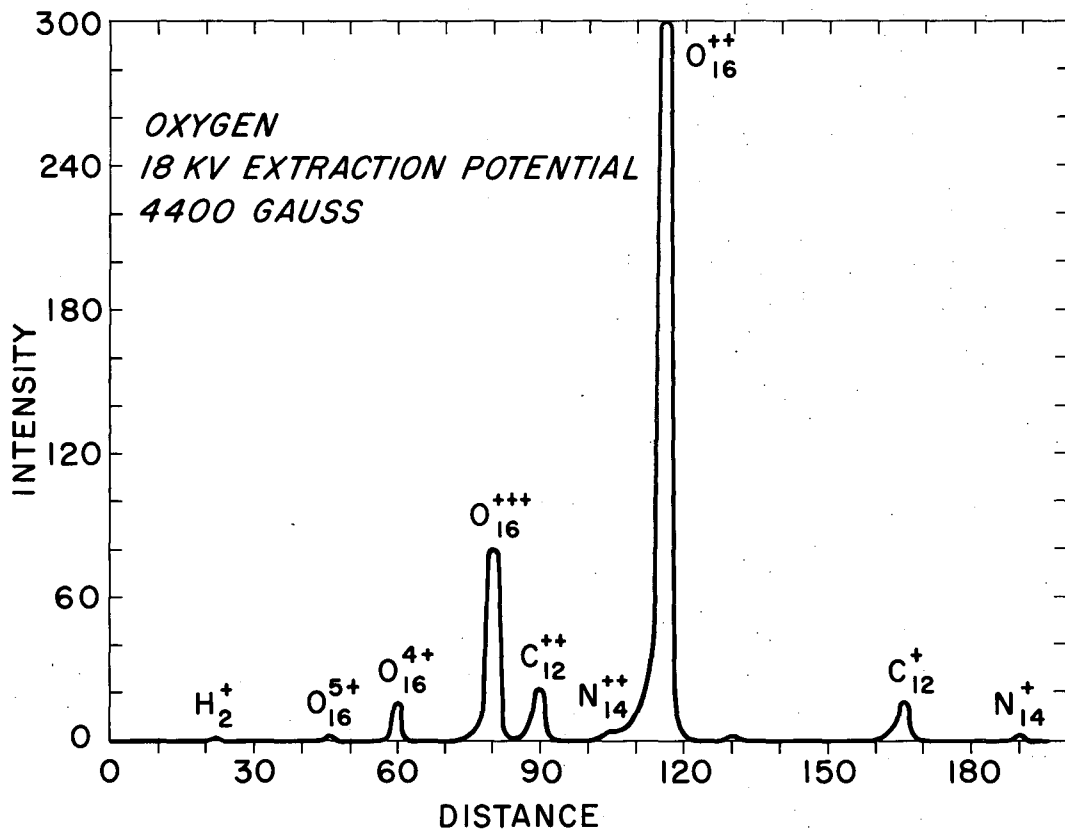

Fig. 14. Nitrogen Spectrum



MU-10526

Fig. 15. Oxygen Spectrum.

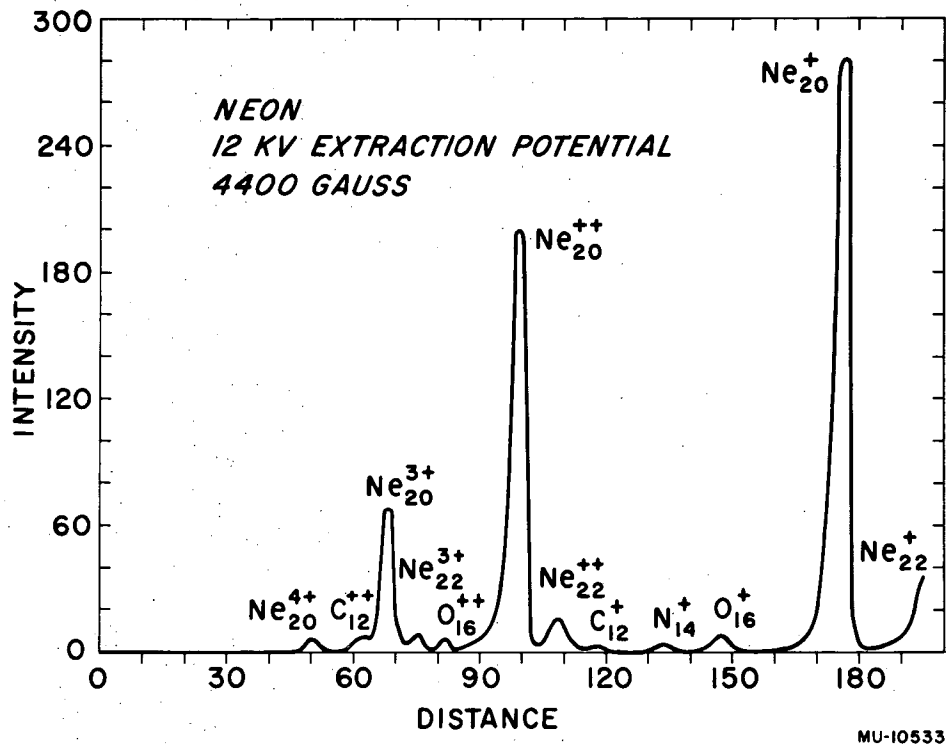

Fig. 16. Neon Spectrum

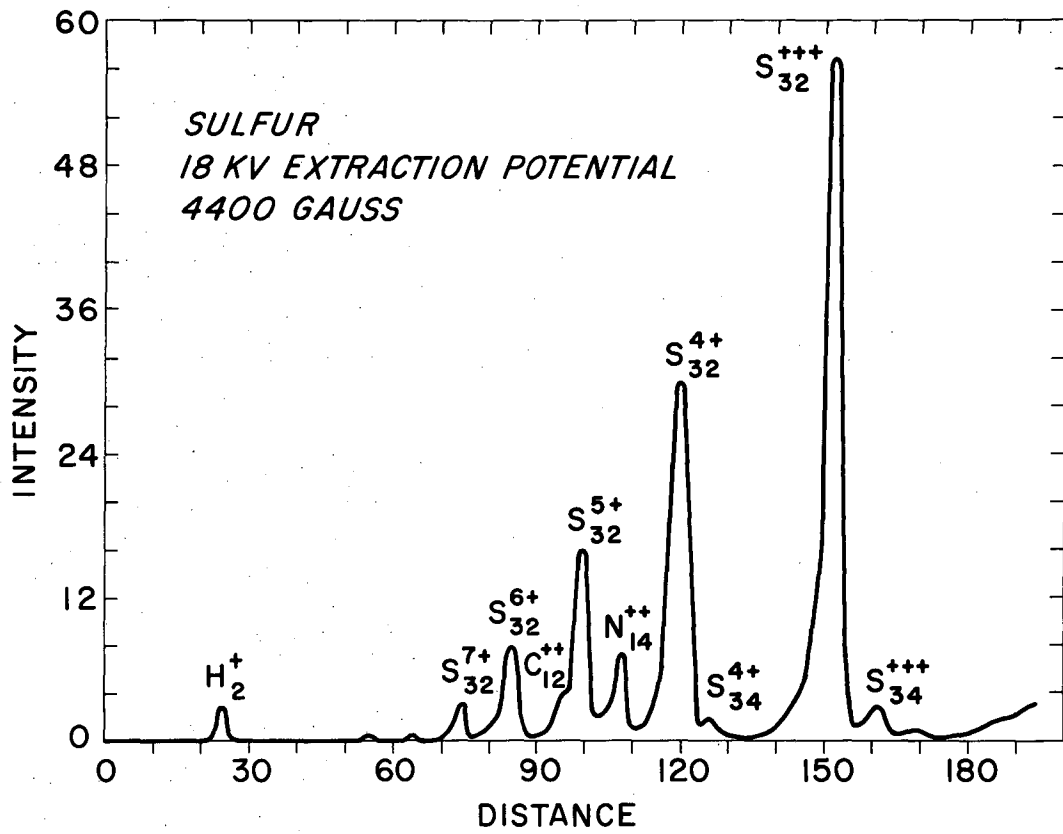

Fig. 17. Sulfur Spectrum

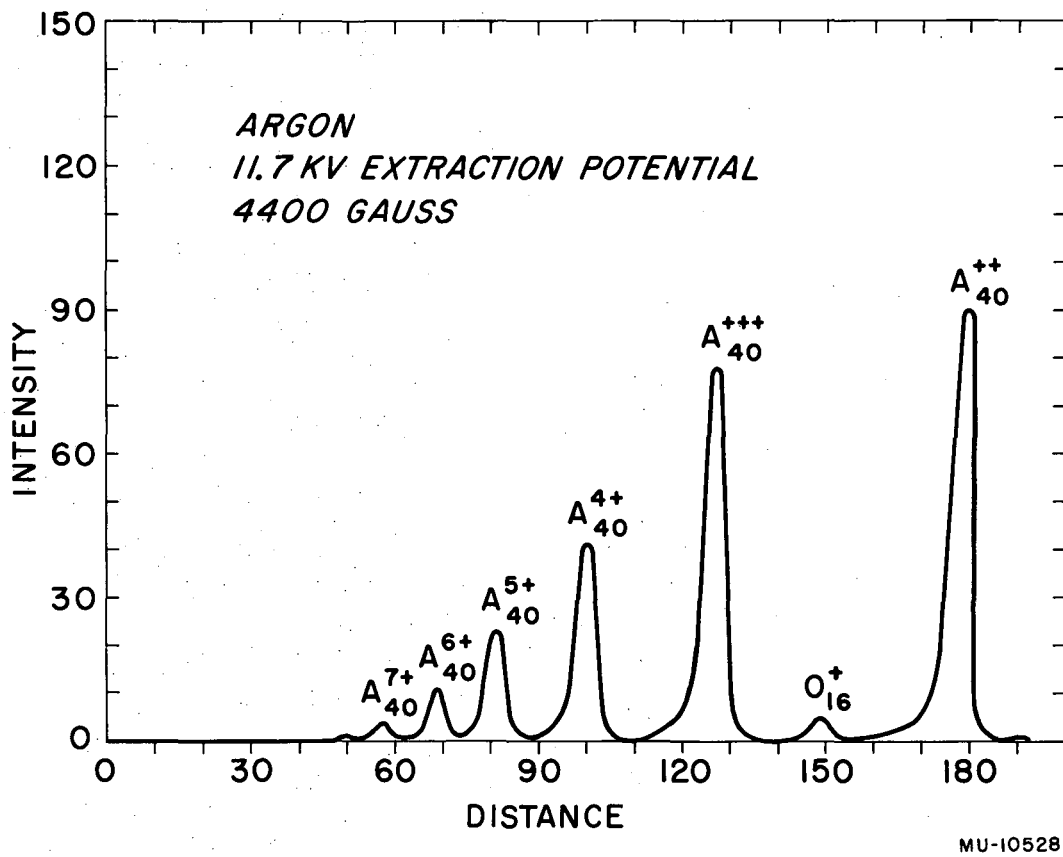

Fig. 18. Argon Spectrum

Helium

The helium run (Fig. 12) was made by using commercial helium gas and with the arc operating conditions of 1.4 amp and 2000 volts. Operating pressure was 8.5×10^{-6} or a gas flow rate of approximately 6 cc/min. The total integrated current shown is 29 ma. Although hydrogen was present in the helium spectrum, it is felt that the results of the hydrogen spectrum (Fig. 11) indicate the large majority of current in the He_4^{2+} - H_2^+ peak (2 ma) is He_4^{2+} (alpha particles).

Carbon

Methane (CH_3) was tried as a gas from which to produce carbon. However, after a short period of operation, the arc current dropped drastically to a level of a few hundred milliamperes. Upon removal of the cathodes, it was noted that a thin layer of carbon had deposited out, and in effect the arc was operating as if the cathodes were made of carbon. A subsequent attempt was made in which CO_2 was used as the gas, and this proved successful. In this case (Fig. 13) the oxygen serves to remove the deposited carbon from the cathode surfaces. Inspection of the cathodes after this run disclosed no sign of carbon. The arc was operated at 1.3 amp and 1450 volts at a vessel pressure of 7×10^{-6} mm Hg, or a gas flow rate of approximately 0.5 cc/min. The C_{12}^{2+} peak has 1.7 ma out of an integrated total of 11 ma.

Nitrogen

Most of the experimental work done was with nitrogen gas. The spectrum shown in Fig. 14 was with the arc operating at 1.3 amp and 2000 volts. The vessel pressure was 7×10^{-6} , which corresponds to a gas flow rate of about 0.7 cc/min. Here 1.8 ma of N_{14}^{3+} was obtained from a total integrated current of 22.5 ma.

Later work, with longer extraction slits and higher ion outputs, produced up to 5 milliamperes of N_{14}^{3+} .

Oxygen

The oxygen spectrum (Fig. 15) was obtained with the arc operating at 1 amp and 2200 volts, with a gas flow rate of approximately 0.9 cc/min of O_2 gas. The integrated current, which does not include the O_{16}^+ beam, was 16.15 ma, of which 2.2 ma is contained in the O_{16}^{3+} line.

Neon

The arc with neon gas (Fig. 16) operated at 1 amp and 2500 volts, and with a gas flow rate of approximately 2 cc/min. Two milliamperes of Ne_{20}^{3+} resulted from a total beam integration of 20 ma.

Sulfur

The sulfur spectrum obtained in Fig. 17 was with H_2S gas. This arc ran quite well at 0.8 amp and 2700 volts, and no difficulty with the sulfur sticking on the cathode surfaces was encountered. No data on ion gauge calibration were available for H_2S gas, but the vessel pressure was approximately 6×10^{-6} during the operation.

The spectrum shown, which does not include the low-charge states or hydrogen, has an integrated current of 6 ma, of which the S_{32}^{5+} peak represents 0.5 milliamperes.

Argon

Operating on argon gas, the arc ran at 0.9 amp and 2900 volts. The vessel pressure of 7×10^{-6} indicated a gas flow rate of about 0.7 cc/min. There was 0.3 milliamperes of argon A_{40}^{6+} in an integrated total of 10.1 milliamperes. (Fig. 18.)

Boron

Operation of the arc with boron trifluoride (BF_3) was tried, but was not too successful. A condition quite similar to the operation with methane existed, and the cathodes soon became contaminated. This resulted in intense arc instability as well as considerable high-voltage breakdown from the extractor to the anode. Spectra of the ion output were taken, but are not included as arc conditions could not be stabilized. Visual inspection of the cathodes following the run showed a surface deposit. The extractor had also received a deposit of boron near the slit, and where the deposit was thick it was flaking off, hence initiating breakdown.

No further attempts were made to operate with boron. It is felt that fluorine gas would operate successfully, but the presence of fluorine in the vacuum system during operation with BF_3 resulted in surface pitting of the stainless steel liquid nitrogen trap, and consideration would have to be given to vacuum problems before operation with this gas.

This work was done under the auspices of the U. S. Atomic Energy Commission.

REFERENCES

1. H. L. Reynolds, D. W. Scott, and A. Zucker, Phys. Rev. 95, 671 (1954).
2. G. B. Rossi, W. B. Jones, J. M. Hollander and J. G. Hamilton, Phys. Rev. 93, 256 (1954).
3. D. Walter and J. H. Fremlin, Nature 171, 189 (1933).
4. H. Atterling, Arkiv Fysik 7, 503 (1954).
5. R. Jones and A. Zucker, Rev. Sci. Inst. 25, 562 (1954).
6. F. Keywell, Phys. Rev. 97, 1611 (1955).
7. G. Wehner, Phys. Rev. 93, 633 (1954).
8. J. R. Pierce, J. Appl. Phys. 11, 548 (1940).
9. B. J. Thompson and L. B. Headrick, Proc. Inst. Radio Eng., Vol 28, 319 (1940).
10. I. P. Smith, W. E. Parkins, and A. T. Forrester, Phys. Rev. 72, 989 (1947).
11. R. Bernas, L. Kaluszyner and J. Druaux, Jour. de Physique et le Radium, 13, 273 (1954).
12. S. Dushman and A. H. Young, Phys. Rev. 68, 278 (1945).
13. S. Wagener and C. B. Johnson, Jour. Sci. Inst. 28, 278 (1951).

This report was prepared as an account of Government sponsored work. Neither the United States, nor the Commission, nor any person acting on behalf of the Commission:

- A. Makes any warranty or representation, expressed or implied, with respect to the accuracy, completeness, or usefulness of the information contained in this report, or that the use of any information, apparatus, method, or process disclosed in this report may not infringe privately owned rights; or
- B. Assumes any liabilities with respect to the use of, or for damages resulting from the use of any information, apparatus, method, or process disclosed in this report.

As used in the above, "person acting on behalf of the Commission" includes any employee or contractor of the Commission, or employee of such contractor, to the extent that such employee or contractor of the Commission, or employee of such contractor prepares, disseminates, or provides access to, any information pursuant to his employment or contract with the Commission, or his employment with such contractor.