

Ionic Conductances of Extracellular Shunt Pathway in Rabbit Ileum

Influence of shunt on transmural sodium transport and electrical potential differences

RAYMOND A. FRIZZELL and STANLEY G. SCHULTZ

From the Department of Physiology, University of Pittsburgh School of Medicine,
Pittsburgh, Pennsylvania 15213

ABSTRACT The unidirectional influxes of Na, K, and Cl into isolated strips of rabbit ileum are comprised of movements across the mucosal membrane of the epithelial cells and ionic diffusion into an extracellular shunt pathway. A large fraction of the Na influx across the mucosal membrane alone is inhibited by Li, suggesting the participation of a carrier mechanism in the influx process. The partial ionic *shunt* conductances of Na, K, and Cl account for at least 82% of the total tissue conductance. The calculated shunt permeabilities (P) are (in centimeters per hour) $P_K = 0.040$, $P_{Na} = 0.035$, and $P_{Cl} = 0.019$, so that $P_K:P_{Na}:P_{Cl} = 1.14:1.00:0.55$. Diffusion potentials across the tissue resulting from isotonic replacement of NaCl in the mucosal solution with mannitol or KCl are described by the Goldman constant-field equation together with the above permeabilities of the shunt pathway. These observations are not consistent with permeation through a fixed-charge pore but can be explained by a model featuring constant ionic partition into a neutral-polar pore that traverses the tight junction. Such a pore may be lined with either fixed dipoles or fixed dipolar ions oriented such that electronegative groups influence the permselective properties of the diffusion pathway. The essential feature of both models is that electroneutrality is maintained by means of *fixed membrane components* and does not depend upon the presence of *mobile counterions*.

In recent years, increasing attention has been focused on the role of transmural, extracellular pathways in the transport of solutes and water by a variety of epithelial tissues. However, the conductance properties of these pathways have not been defined directly because studies of transmural ionic fluxes, diffusion potentials, or streaming potentials do not clearly distinguish between the properties of extracellular and transcellular routes for ion flow.

As a result of recent studies of the electrical potential profile across rabbit ileum, Rose and Schultz (1) have suggested an equivalent electrical circuit model for this tissue that features a low-resistance, transepithelial, extracellular shunt. The relative resistive properties of the shunt and of the mucosal and serosal cell membranes suggested the present investigation which is concerned with a direct evaluation of the partial ionic conductances of the extracellular pathway. Evidence is presented that at least 85% of the transmural conductance can be attributed to this extracellular pathway, and the implications of these findings with respect to the interpretation of transmural electrical potential differences are discussed.

THEORETICAL CONSIDERATIONS

The essential resistive elements of the model proposed by Rose and Schultz (1) are illustrated in Fig. 1. R'_m is the resistance of the mucosal membrane,

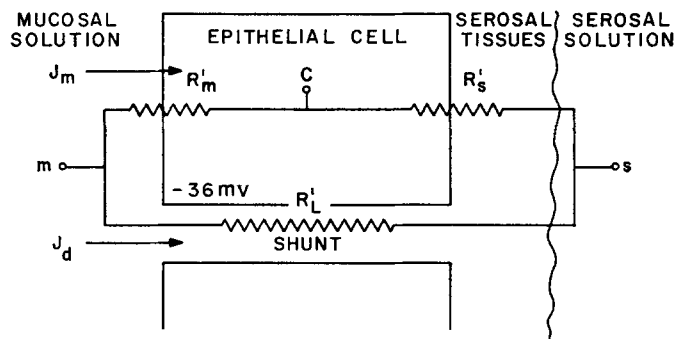

FIGURE 1. Resistive pathways in rabbit ileum.

R'_s is the combined resistance of the serosal membrane and the underlying serosal tissues, and R'_L is the resistance of the parallel, transmural shunt. The electrical potential difference (Ψ) across the mucosal membrane, Ψ_{mc} , averages 36 mv, cell interior negative (1).¹ Studies of the relative resistances of R'_m and R'_s , performed by passing a 200 μ a pulse of direct current across the tissue during a successful cell impalement, indicate that the change in Ψ_{mc} in response to an external current in the unstripped preparation is less than 10% of the change in total transmural potential difference, Ψ_{ms} ; the average $\Delta\Psi_{mc}/\Delta\Psi_{ms}$ in eight determinations was 0.07 ± 0.01 . Thus, the effect of an external transmural current on Ψ_{mc} is very small compared to its effect on Ψ_{ms} .

The underlying assumption of our approach is that the unidirectional influx of a charged species from the mucosal solution into the epithelium is composed of at least two parallel components (Fig. 1). One component, J_m , represents the unidirectional influx across the mucosal membrane. This

¹ All electrical potential differences are given with reference to the mucosal solution (zero electrical potential). Thus, $\Psi_{ms} = \Psi_s - \Psi_m$ and $\Psi_{mc} = \Psi_c - \Psi_m$.

component, which itself may be comprised of carrier-mediated as well as diffusional flows, is assumed to a first approximation to be unaffected by small changes in Ψ_{m_c} . The second component, J_d , represents the unidirectional influx into the transmural shunt pathway. This component is assumed to be due to ionic diffusion and, therefore, to be directly affected by Ψ_{m_s} . Schultz and Zalusky (2) have demonstrated that the unidirectional diffusional flow of a charged species is closely approximated by

$$J_d = {}_0J_d [\exp (z\mathfrak{F}\Psi_{m_s}/RT)]^{-1/2} \quad (1)$$

where J_d is the unidirectional flux at any Ψ_{m_s} and ${}_0J_d$ is the unidirectional flux under short-circuit conditions. \mathfrak{F} , R , T , and z have their conventional meanings. The error of this approximation is less than 6% over the range $\Psi_{m_s} = \pm 25$ mv and is 13% when $\Psi_{m_s} = \pm 50$ mv. This approximation is adequate for the present purposes (because the underlying assumptions have important bearing on the subsequent discussion, this derivation is given in the Appendix).

If these assumptions are correct, the unidirectional influx (J_i) of a charged species, i , should be given by

$$J_i^i = J_m^i + {}_0J_d^i \xi^{-1/2} \quad (2)$$

where $\xi = \exp (z_i\mathfrak{F}\Psi_{m_s}/RT)$. Thus, J_i^i should be a linear function of $\xi^{-1/2}$ with an intercept on the ordinate that corresponds to J_m^i and a slope that corresponds to ${}_0J_d^i$. As discussed previously, for a univalent ion, ${}_0J_d^i$ in micromoles per hour per square centimeter is numerically equal to the partial ionic conductance of the charged species expressed in millimhos per square centimeter (3).

METHODS

Male white rabbits were sacrificed with intravenous pentobarbital and a section of terminal ileum was excised, opened along the mesenteric border, and rinsed free of intestinal contents. The segment was mounted as a flat sheet, mucosal surface up, in the apparatus shown schematically in Fig. 2. This apparatus permits exposure of defined areas (1.13 cm²) of the mucosal surface to solutions of desired composition; the serosal surface rested on nylon mesh and was in direct contact with a serosal solution whose composition was identical to that of the mucosal solution. The nylon mesh supported the tissue and permitted its prompt removal from the chamber at the completion of the experiment. The serosal solution was continuously stirred with a magnetic stirring bar, and the mucosal solution was bubbled vigorously with a fine stream of humidified 95% O₂-5% CO₂. All experiments were performed at 37°C; the buffered electrolyte solution contained 140 mM NaCl, 10 mM KHCO₃, 1.2 mM K₂HPO₄, 0.2 mM KH₂PO₄, 1.2 mM CaCl₂, and 1.2 mM MgCl₂ and had a pH of 7.4. In several experiments, NaCl was partially replaced with an isosmotic equivalent of choline chloride, LiCl, or Na₂SO₄ plus mannitol.

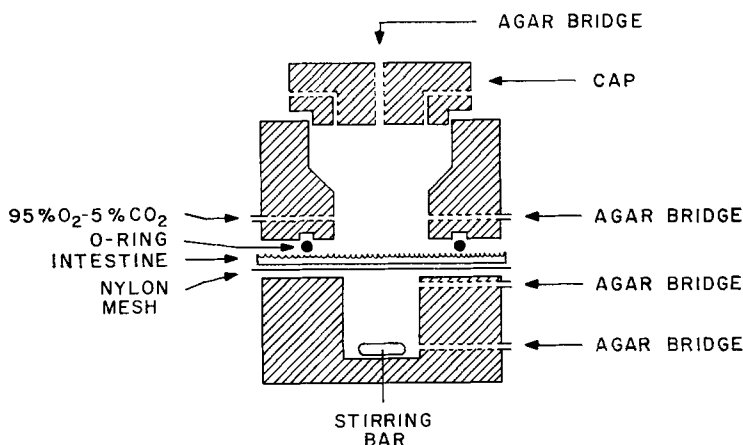

FIGURE 2. Schematic diagram of a portion of the apparatus used for measuring unidirectional ion influxes under voltage-clamp conditions. A single port is shown; the complete apparatus consisted of four ports in a row. Using two chambers of this type permitted eight influx determinations on tissue from the same animal.

Electrical Measurements

The tips of Ringer-agar bridges (1.6 mm I.D.) were placed adjacent to each surface of the tissue as indicated in Fig. 2, and the potential difference (PD) between these bridges was measured by a pair of matched calomel electrodes leading to a high-impedance electrometer (Kiethley Instruments, Inc., Cleveland, Ohio, model 692A). External current was applied via agar bridges inserted into the cap of the mucosal chamber and the base of the serosal reservoir. Each current bridge was connected via an Ag-AgCl electrode to a variable electromotive force. The magnitude of the applied current was determined using a Weston DC microammeter (Weston Instruments, Newark, N.J.). In this manner, sufficient external current could be applied to voltage clamp the tissue over a wide range of transmural PDs (± 50 mv). Since rabbit ileum is a low resistance tissue (1, 2), the resistance of the bathing solution between the PD recording bridges and the tissue surfaces is significant. Therefore, the resistance of the fluid gap was evaluated in the absence of tissue and all values of Ψ_{ms} were corrected for the potential drop across this fluid resistance.

Voltage-Clamp Influx

The technique used to measure the unidirectional influx of solute from the mucosal solution into the epithelium has been described (4). Tissues were preincubated for approximately 15 min using mucosal and serosal solutions having the same composition as that used for the influx determination. During this time, the DC resistance of the system was determined, and immediately before the influx measurement the transmural PD was clamped at a constant value. The mucosal preincubation solution was then withdrawn and replaced by a *test* solution containing inulin- ^3H and either ^{22}Na , ^{36}Cl , or ^{42}K via a fluid inlet adjacent to the mucosal recording electrode. As the test solution was injected into the mucosal chamber, the transmural PD rose rapidly

to the value at which the tissue was previously clamped and remained constant during the 50 sec exposure to the mucosal solution. The mucosal solution was then withdrawn, the chamber was flushed with ice-cold, isotonic mannitol solution, and the exposed area of tissue was cut out, washed briefly in 0.3 M ice-cold mannitol solution, and extracted for at least 2 hr in 0.1 N HNO₃. The unidirectional ion influx was calculated from the tracer content of the tissue after correction for the volume of adherent test medium as given by the inulin-³H "space" (4, 5). In several experiments the serosal solution was withdrawn before removal of the tissue and assayed for tracer activity. The absence of serosal radioactivity indicated that all of the tracer that entered the tissue from the mucosal solution was retained within the tissue during the brief test period.

It should be noted that the O-ring illustrated in Fig. 2 prevents crushing of the tissue between the Lucite half chambers. Thus, measurements of tissue resistance and influx are not complicated by "edge" effects. The average tissue conductance in these experiments (10 mmho/cm²) is only 60% of that reported by Schultz and Zalusky (2) and edge effects may have contributed to the higher conductance observed in these earlier studies.

Diffusion Potentials

Flat sheets of ileum were clamped between the halves of the chamber illustrated in Fig. 2. The tissue was bathed on both sides by the standard electrolyte solution containing 10⁻³ M ouabain, and Ψ_{ms} was recorded as described above using 3% agar bridges containing the standard electrolyte solution. After approximately 45 min, the spontaneous Ψ_{ms} had declined to zero, and the composition of the mucosal solution was then serially diluted with electrolyte solutions in which either 300 mM mannitol or 150 mM KCl replaced 150 mM NaCl. The absence of an initial transmural PD was taken to indicate that active ion transport by the tissue had ceased (2) so that the transmural PDs resulting from changing the composition of the mucosal solution reflected only diffusion potentials across the tissue. The values reported are steady-state values that were achieved within 1 min after changing the composition of the mucosal solution; these values remained constant for the 5 min interval between serial dilutions.

The experimental data are complicated by asymmetric junction potentials, arising at the tips of the potential-measuring electrodes, which can neither be measured directly nor calculated satisfactorily. This asymmetry could have been minimized through the use of saturated KCl-agar electrodes; however, because of the small volumes of the mucosal and serosal solutions, leakage of KCl from these electrodes would have significantly altered the composition of the bathing solutions and this approach was precluded. The following procedure was employed in order to circumvent this problem. A sheet of Parafilm (American Can Co., Neenah, Wis.) was mounted between the half chambers and the mucosal and serosal compartments were filled with the standard electrolyte solution. The two compartments were connected by means of a saturated KCl-agar (salt) bridge and the PDs were determined during serial dilution of the mucosal solution using agar electrodes containing the standard electrolyte (Ringer) solution. These PDs include (a) the asymmetry at the

Ringer-agar junctions *plus* (*b*) the *difference* between the junction PDs at the two ends of the saturated KCl-agar bridges. Subtraction of these data from the observed transmural PDs eliminates the large asymmetry arising from the Ringer-agar electrodes and substitutes, in its place, the much smaller asymmetry arising from the saturated KCl-agar bridge (i.e., the results are formally identical with what would have been observed had saturated KCl-agar electrodes been employed in the determination of transmural PDs). As discussed by Caldwell (6) and demonstrated by Picknett (7), these corrected PDs are not likely to be in error by more than 1–2 mv.

RESULTS

Voltage-Clamp Ion Influxes

SODIUM The relation between the unidirectional influx of Na, from a mucosal solution containing 140 mM Na, and Ψ_{ms} (expressed as $\xi^{-1/2}$) is illustrated in Fig. 3. The data are described by a regression line having a slope (${}_0J_d^{Na}$) of 4.9 ± 0.9 (SE of the mean) $\mu\text{mole}/\text{cm}^2$ per hr and an intercept (J_m^{Na}) of $16.2 \mu\text{mole}/\text{cm}^2$ per hr. All regression lines reported are significant at the $P < 0.01$ level. Although there is considerable scatter of these data, further inspection indicated that the points from single experiments tended to fall into populations having similar slopes but different intercepts. For example, the data from a single experiment on eight adjacent segments of

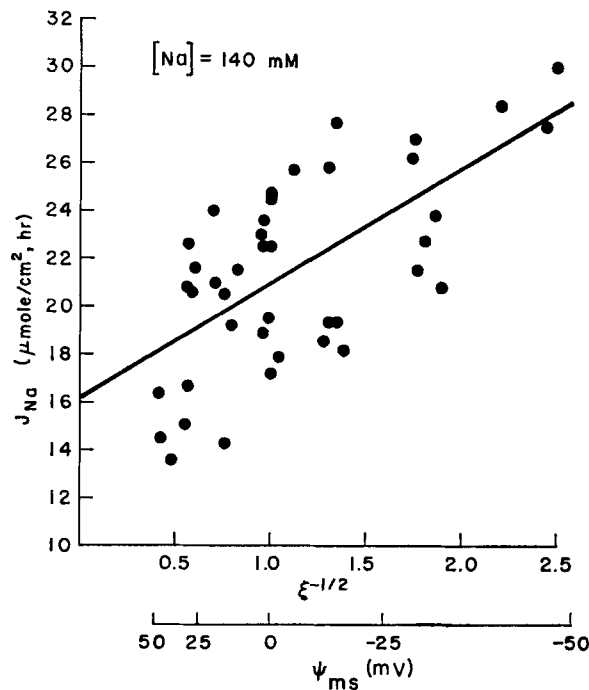

FIGURE 3. Effect of Ψ_{ms} on sodium influx. $[\text{Na}]_m = 140 \text{ mM}$.

tissue from the same animal are plotted in Fig. 4; the slope of the line is identical with that of the line shown in Fig. 3. However, the standard error of the intercept in Fig. 3 is three times that of Fig. 4, suggesting that the scatter in Fig. 3 results from animal-to-animal variation in J_m^{Na} ; that is, in the frac-

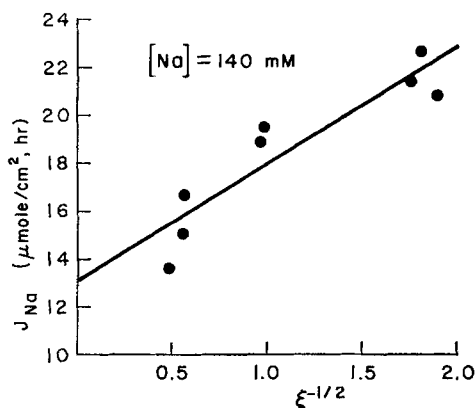

FIGURE 4. Effect of Ψ_{ms} on sodium influx. The data are from a single experiment on tissue from the same animal.

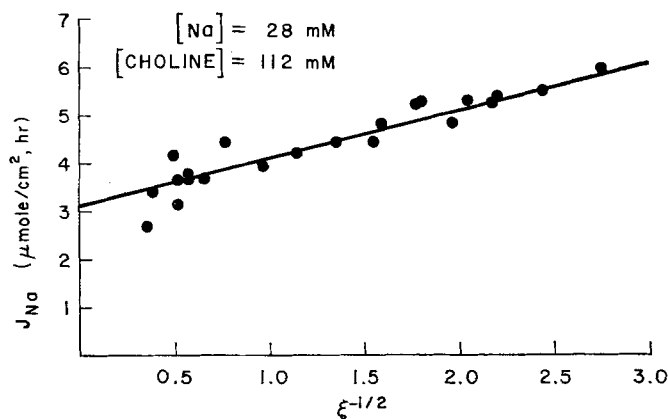

FIGURE 5. Effect of Ψ_{ms} on sodium influx. NaCl was partially replaced with choline chloride. $[\text{Na}]_m = 28 \text{ mM}$.

tion of Na influx that crosses the mucosal membrane. The values for J_i^{Na} obtained in these studies are in excellent agreement with those obtained using the influx apparatus that does not feature a serosal chamber (4).

The effect of Ψ_{ms} on Na influx at an Na concentration, $[\text{Na}]_m$, of 28 mM is illustrated in Fig. 5. NaCl in both mucosal and serosal solutions was partially replaced with choline chloride. The linear regression analysis gave values for J_d^{Na} and J_m^{Na} of 1.0 and 3.1 $\mu\text{mole}/\text{cm}^2$ per hr, respectively. These values are approximately one-fifth those observed in the presence of 140 mM Na,

indicating that both components of Na influx are linear functions of the Na concentration in the mucosal solution over the concentration range employed. These findings are consistent with previous observations that J_i^{Na} , under open circuit conditions, is a linear function of mucosal Na concentration (8).

Although J_m^{Na} is directly proportional to the Na concentration in the mucosal solution, Schultz et al. (4) have suggested that the entry of Na into the mucosal cell across the brush border may not be entirely attributable to simple diffusion since a substantial fraction of Na influx can be inhibited by Li or K in the mucosal solution. They suggested that these observations could be explained by a carrier-mediated entry step with affinity for Na, K, and Li which cannot be saturated at prevailing mucosal Na concentrations. If this

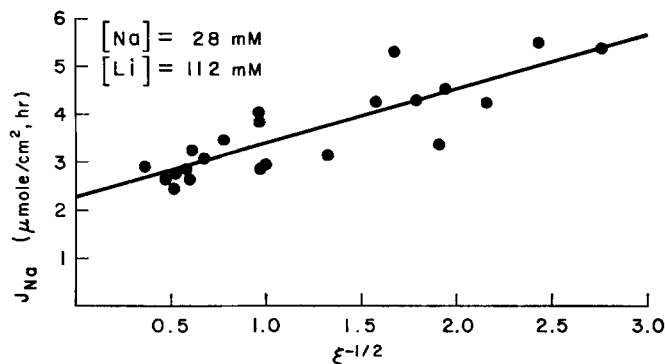

FIGURE 6. Effect of Ψ_{ms} on sodium influx. NaCl was partially replaced with LiCl. $[Na]_m = 28$ mM.

is correct, Li would be expected to inhibit J_m^{Na} without affecting Na influx into the extracellular pathway. Fig. 6 shows the results of experiments identical to those of Fig. 5, except that 112 mM LiCl was used as the partial replacement for NaCl. These results show that replacement of choline with Li has no significant effect on J_d^{Na} , whereas J_m^{Na} was inhibited by 27% in the presence of 112 mM Li ($P < 0.01$).

To evaluate the fraction of J_m^{Na} that is subject to inhibition by Li, J_i^{Na} was determined from isosmotic mucosal solutions containing 28 mM Na and varying concentrations (0–112 mM) of Li; the Li concentration was varied by replacing choline with Li.² The relative Na influx is plotted as a function of $1/[Li]_m$ in Fig. 7. Clearly, relative Na influx decreases with increasing $[Li]_m$ and extrapolation of the line to the ordinate suggests that 37% of Na influx is not subject to inhibition by Li (e.g. this is the residual influx in the presence

² Influxes in the presence and in the absence of Li were determined on adjacent segments of tissue from the same animals. These internally controlled experiments provide a more reliable quantitation of the inhibitory effect of Li than does comparison of the intercepts of Figs. 5 and 6.

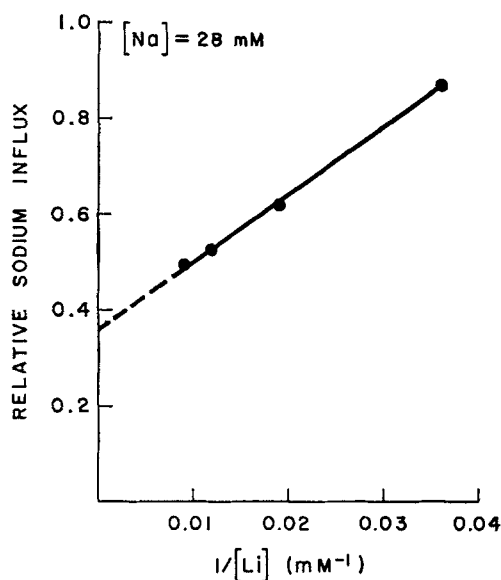

FIGURE 7. Effect of lithium on sodium influx. Each point is the average of four determinations of Na influx under open-circuit conditions.

of infinite $[Li]_m$). The data in Figs. 5 and 6 suggest that if J_m^{Na} were subject to complete inhibition by high concentrations of Li, only that portion of the total influx equal to J_d^{Na} would remain unaffected. When $[Na]_m = 28 \text{ mM}$, $\Psi_{m,s}$ is close to zero (2) so that $\xi^{-1/2} \cong 1$. From Fig. 5, when $\xi^{-1/2} \cong 1$, $J_d^{Na} = 1.0 \text{ } \mu\text{mole/cm}^2 \text{ per hr}$ and $J_m^{Na} = 3.1 \text{ } \mu\text{mole/cm}^2 \text{ per hr}$. Thus, if $J_m^{Na} = 0$ when $[Li]_m = \infty$, the residual Na influx would be 25% of the influx in the absence of Li. This does not differ markedly from the value of 37% deduced from the extrapolation in Fig. 7 and is consistent with the conclusion that 85% (2.6 $\mu\text{mole/cm}^2 \text{ per hr}$ out of 3.1 $\mu\text{mole/cm}^2 \text{ per hr}$) of J_m^{Na} is subject to inhibition by Li. In view of the fact that Na influx is not a saturable function of $[Na]_m$, there is no formal kinetic treatment that describes competitive interactions. Thus, the plot shown in Fig. 7 is entirely empirical and there is no rigorous justification for the linear extrapolation. However, it should be noted that 50% inhibition of Na influx was observed in the presence of 112 mM Li, so that even if no greater inhibition could be produced by higher Li concentrations, at least 66% of J_m^{Na} would be subject to inhibition by Li.

CHLORIDE The effect of $\Psi_{m,s}$ on Cl influx from a mucosal solution containing 145 mM Cl is illustrated in Fig. 8. The linear regression analysis of these data gives values for J_d^{Cl} and J_m^{Cl} of 2.8 and 10.3 $\mu\text{mole/cm}^2 \text{ per hr}$, respectively.

Measurements of J_i^{Cl} vs. $\Psi_{m,s}$ were also obtained following reduction of mucosal chloride concentration to 50 mM by isosmotic replacement with

Na_2SO_4 and mannitol; the results of these experiments are shown in Fig. 9. There is a proportional decline in ${}_0J_d^{\text{Cl}}$ to a value of $1.0 \mu\text{mole}/\text{cm}^2$ per hr, a result consistent with a diffusional process. In contrast, J_m^{Cl} does not undergo a proportional decrease at the reduced chloride concentration; a 65% reduc-

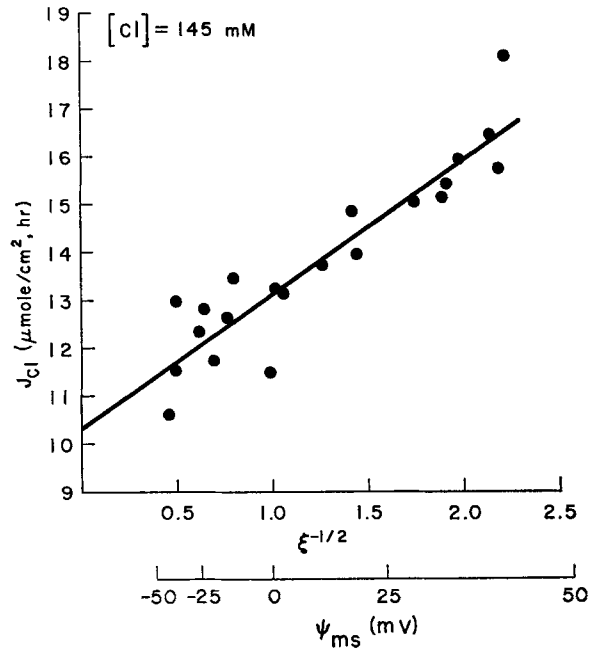

FIGURE 8. Effect of Ψ_{ms} on chloride influx. $[\text{Cl}]_m = 145 \text{ mM}$.

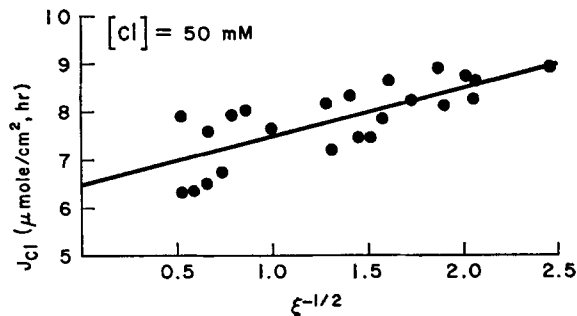

FIGURE 9. Effect of Ψ_{ms} on chloride influx. $[\text{Cl}]_m = 50 \text{ mM}$.

tion in $[\text{Cl}]_m$ results in only a 37% decrease in J_m^{Cl} , which suggests that the influx of chloride across the mucosal border is a nonlinear function of $[\text{Cl}]_m$. These observations are consistent with other data obtained in this laboratory which indicate that Cl influx across the mucosal membrane is a saturable function of $[\text{Cl}]_m$ that conforms to Michaelis-Menten kinetics (Frizzell, Markscheid-Kaspi, and Schultz, unpublished observations).

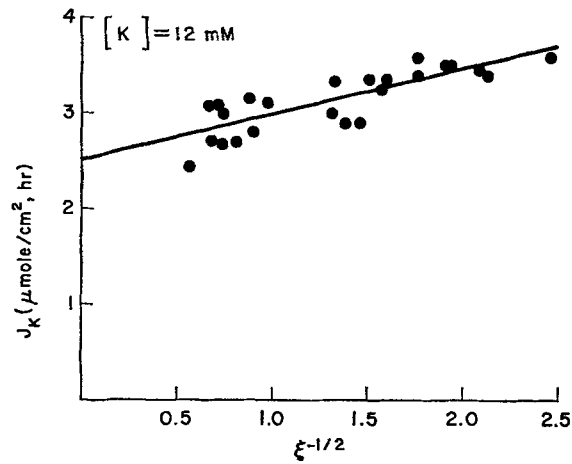

FIGURE 10. Effect of Ψ_{ms} on potassium influx. $[K]_m = 12$ mM.

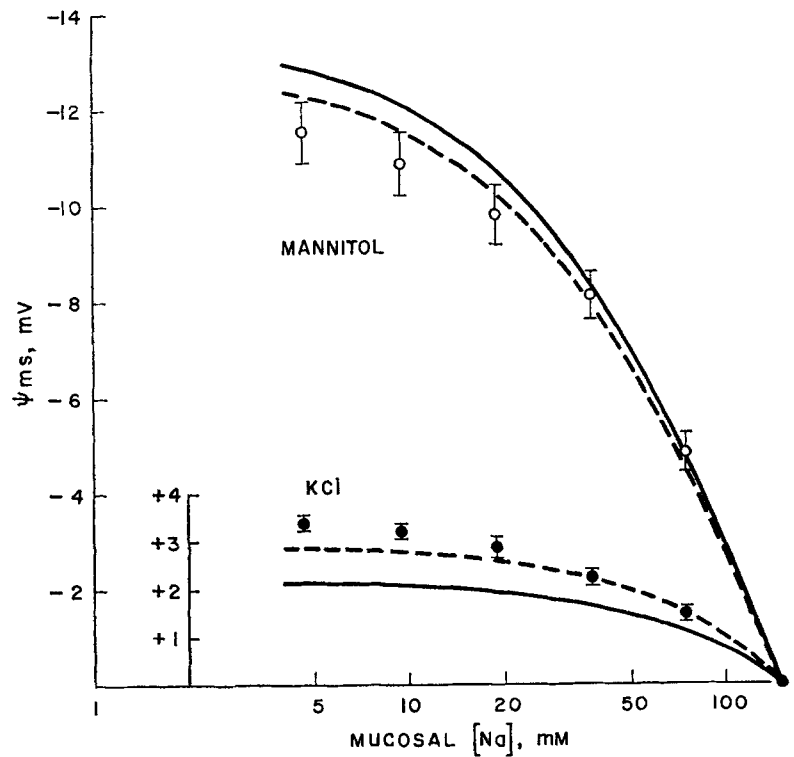

FIGURE 11. Diffusion potentials across rabbit ileum. The values of Ψ_{ms} for mannitol replacement are given on the larger ordinate; those for KCl replacement are given on the smaller ordinate. All data are corrected for junction potentials as described in Methods. The solid curves are obtained using equation 6 and the data given in Table I.

POTASSIUM Potassium influx as a function of Ψ_{ms} is shown in Fig. 10. These experiments were carried out using the standard electrolyte solution with a K concentration of 12 mM. The regression line describing these data indicates that $J_m^K = 2.5 \mu\text{mole}/\text{cm}^2$ per hr and ${}_0J_d^K = 0.48 \mu\text{mole}/\text{cm}^2$ per hr.

Diffusion Potentials

The effects on Ψ_{ms} of replacing NaCl in the mucosal solution either with mannitol (so that both $[\text{Na}]_m$ and $[\text{Cl}]_m$ are reduced), or with KCl are illustrated in Fig. 11. In these experiments, 10^{-3} M ouabain was included in the perfusion solutions and replacements commenced after the spontaneous Ψ_{ms} (3–5 mv) had declined to zero. This procedure assures that the effects of Na (or NaCl) replacement can be attributed entirely to diffusion potentials uncomplicated by the effects of a reduced $[\text{Na}]_m$ on the spontaneous Ψ_{ms} (2). Qualitatively similar results have been observed in a few experiments in which the spontaneous Ψ_{ms} was low (about 1–2 mv) and treatment with ouabain was omitted. When NaCl in the mucosal solution was replaced isosmotically with mannitol, the mucosal solution became electrically positive with respect to the serosal solution. In contrast, replacement of Na in the mucosal solution with K had a smaller effect on Ψ_{ms} and the mucosal solution became electrically negative with respect to the serosal solution. The significance of the curves will be discussed later. Qualitatively similar effects have been observed using rat (9) and tortoise (10) small intestine and rabbit (11) and fish (12) gall bladder.

CONCLUSIONS

Justification of the Model

As discussed above, this approach is based on the assumption that the total unidirectional influx from the mucosal solution into the epithelium across the luminal surface may be subdivided into two parallel components: (a) a component, J_m , that represents movement across the mucosal membrane of the epithelial cells and is not significantly affected by small changes in Ψ_{mc} , and (b) a diffusional component, J_d , that enters a transepithelial, extracellular pathway and is directly influenced by an imposed, transepithelial electrical field. Several experimental observations support this assumption:

(a) Simultaneous measurements of Ψ_{mc} and Ψ_{ms} during passage of a direct current across the tissue indicate that $\Delta\Psi_{mc}/\Delta\Psi_{ms} = 0.07$. Thus, voltage clamping the tissue over the range ± 50 mv affects the spontaneous Ψ_{mc} by only ± 3.5 mv. The average Ψ_{mc} in the absence of an external current is 36 ± 7 (SD) mv (1). Thus, the largest currents employed in these studies did not alter Ψ_{mc} by more than 10%, an effect that is within one standard deviation from the average spontaneous Ψ_{mc} and is not expected to significantly in-

fluence the unidirectional influxes of monovalent ions (see equation 1). It should be stressed that this assumption does not imply that J_m is unaffected by electrical fields across the mucosal membrane, but rather that the external currents employed in these studies are insufficient to produce large changes in $\Psi_{m,c}$.

(b) Na influx from a solution containing 28 mM Na is significantly lower when Li is used to replace Na than when choline is employed as the substitute cation (4). This inhibitory effect of Li is restricted to J_m^{Na} . In contrast, ${}_oJ_a^{Na}$ is unaffected by the nature of the substitute cation and is proportional to the Na concentration in the mucosal solution as would be expected for ionic diffusion.

(c) Cl influx across the luminal surface of rabbit ileum is a nonlinear function of the Cl concentration in the mucosal solution and may be described by a saturable component plus a linear component (Frizzell, Markscheid-Kaspi,

TABLE I
ION FLUXES ACROSS MUCOSAL MEMBRANE AND INTO SHUNT PATHWAY

Ion, [i]	J_m	${}_oJ_a$	P_i
	$\mu\text{mole}/\text{cm}^2 \text{ per hr}$	$\mu\text{mole}/\text{cm}^2 \text{ per hr}$	cm/h
Na, 140 mM	16.2 ± 3.7	4.9 ± 0.9	0.035
Na, 28 mM	3.1 ± 0.1	1.0 ± 0.1	0.036
Cl, 145 mM	10.3 ± 0.8	2.8 ± 0.1	0.019
Cl, 50 mM	6.5 ± 0.1	1.0 ± 0.1	0.020
K, 12 mM	2.5 ± 0.1	0.48 ± 0.01	0.040

and Schultz, unpublished observations). The present studies indicate that J_m^{Cl} is not linearly related to the Cl concentration in the mucosal solution but that ${}_oJ_a^{Cl}$ is. These findings are consistent with the conclusion that the nonlinear component is restricted to influx across the cell membrane whereas influx into the extracellular shunt pathway is attributable to ionic diffusion.

Thus, it is reasonable to conclude that the underlying assumptions of this approach are valid and that the slopes of the lines shown in Figs. 3-6 and 8-10, and summarized in Table I, provide direct measurements of the partial ionic conductances of the transepithelial shunt pathway to Na, Cl, and K. Additional evidence in support of this conclusion is presented later.

Shunt Conductance

When $\Psi_{m,c} = 0$, J_a (expressed in micromoles per hour per square centimeter) is numerically equal to the partial ionic conductance (G_i) expressed in millimhos per square centimeter (3). Thus, for the shunt pathway (in the presence of the standard electrolyte solution), $G_{Na} = 4.9 \text{ mmho}/\text{cm}^2$, $G_{Cl} = 2.8 \text{ mmho}/\text{cm}^2$, and $G_K = 0.48 \text{ mmho}/\text{cm}^2$. The total tissue conductance in these

experiments averaged 10 mmho/cm² so that at least 82% of the total tissue conductance can be attributed to the combined movements of Na, Cl, and K through the transepithelial shunt pathway.³ Assuming that an additional 0.3–0.5 mmho/cm² can be attributed to the combined movements of HCO₃⁻, HPO₄⁻, H₂PO₄⁻, Ca, and Mg, the total conductance of the shunt pathway would account for at least 85% of the total tissue conductance. Thus, the resistance to transcellular ionic movements is at least six times the resistance of the extracellular pathway. Since the resistance of the shunt is at most 120 ohm-cm², the resistance of the transcellular pathway is at least 720 ohm-cm².

The permeability coefficient of the shunt pathway to an ion, i , may be defined by

$$P_i = {}_0J_d^i/[i]_m. \quad (3)$$

This definition has the advantages that P_i : (a) is an unambiguous, phenomenologic coefficient (a unidirectional rate constant) that is readily determined experimentally, (b) is not influenced by electrical asymmetries across the barrier, and (c) is therefore closely analogous to permeability coefficients of nonelectrolytes determined from tracer studies. Thus, $P_K = 0.040$ cm/hr, $P_{Na} = 0.035$ cm/hr, and $P_{Cl} = 0.019$ cm/hr, and $P_K:P_{Na}:P_{Cl} = 1.14:1.00:0.55$. Further, as shown in Table I, P_{Na} and P_{Cl} appear to be independent of the concentrations of these ions in the mucosal solution and P_{Cl} appears, in addition, to be independent of ionic strength.

The observations that $P_K \cong P_{Na}$ and that the total tissue conductance is almost entirely attributable to the conductance of the shunt pathway are consistent with the observations that (a) replacement of Na in the mucosal solution with K does not result in a large transmural diffusion potential, and (b) replacement of Na in both bathing solutions with K does not significantly affect total tissue conductance (13).

The limiting equivalent ionic conductances (λ) of K, Na, and Cl in free solution at 25°C are related as follows:

$$\lambda_K:\lambda_{Na}:\lambda_{Cl} = 1.4:1.0:1.4.$$

Thus, for the shunt pathway, P_K/P_{Na} is only 20% smaller than λ_K/λ_{Na} , indicating that this pathway does not discriminate markedly between these two cations. This observation suggests that the shunt pathway affords a watery environment for ionic diffusion and that Na and K traverse this pathway in

³ The two principle methodologic errors that may influence these measurements are (a) small deviations from linearity in the relation between tracer uptake and time, and (b) tracer loss from the shunt pathway during the brief (3 sec) wash with ice-cold mannitol solution. Both of these errors would reduce our estimates of ${}_0J_d$ so that these values must be considered minimal estimates. These errors cannot be very large because the combined partial ionic conductances cannot exceed 10 mmho/cm² and some contribution must derive from the transcellular route. Further, these errors are not likely to affect our estimates of relative permeabilities.

their hydrated forms. In contrast, P_{Cl}/P_{Na} is 2.5 times lower than the ratio that would be predicted on the basis of free solution mobilities. A possible explanation for this relative restriction on Cl permeability will be discussed below.

In summary: as suggested previously (1), the low transmural resistance of rabbit ileum does not appear to be a consequence of low resistance cell membranes, but instead results from the presence of extracellular shunt pathways. Only a small fraction of the total tissue conductance can be attributed to ion flows *across* the mucosal and serosal membranes; the remainder (at least 85%) is a consequence of ion movements through high conductance extracellular pathways. The remainder of this paper is largely concerned with an analysis of the manner in which these high conductance pathways influence the interpretation of transmural ionic fluxes and electrical potential differences.

Transcellular and Extracellular Routes of Sodium Transport

Previous studies have shown that the volume-average intracellular Na concentration is 40–50 mM (14) and that the cell interior is approximately 36 mv negative with respect to the mucosal solution (1). Thus, entry of Na into the cell from the lumen appears to take place down an electrochemical potential gradient. Nevertheless, the present results add to the evidence that this entry process cannot be attributed to simple ionic diffusion. Previous observations indicated that Na influx is inhibited by high concentrations of Li or K in the mucosal solution and suggested the participation of a carrier mechanism in the influx process (4). The present results permit the distinction between Na influx across the cell membrane and diffusion of Na into an extracellular shunt. The latter is unaffected by Li whereas the former behaves as if it is largely subject to inhibition by Li. If the extrapolation in Fig. 7 is valid, 85% of Na influx across the brush border (J_m^{Na}) is subject to inhibition by Li. Preliminary observations in this laboratory indicate that this effect cannot be attributed to an effect of Li on the transmucosal PD. Thus, these data strongly suggest that a large fraction of the Na influx across the brush border is mediated by a carrier mechanism in spite of the observations that influx is (a) a linear function of the Na concentration in the mucosal solution up to 140 mM and (b) directed down an electrochemical potential difference. Recently, Rotunno et al. (15) and Biber and Curran (16) have directly examined the unidirectional Na influx across the outer surface of isolated frog skin and have obtained evidence that this process is also mediated by a carrier mechanism that is subject to inhibition by K and Li.

Schultz and Zalusky (2) demonstrated that the unidirectional transmural flux of Na from the serosal solution to the mucosal solution, J_{sm}^{Na} , conformed to equation 1, was unaffected by ouabain, and, thus, appeared to be entirely attributable to simple ionic diffusion. This, alone, suggested (4) that most if not all of J_{sm}^{Na} takes place through a shunt pathway; any major transcellular

contribution to J_{sm}^{Na} would be influenced by intracellular Na (which is affected by ouabain) and by at least four unidirectional Na fluxes (4) so that close conformity with equation 1 would be unlikely. Under short-circuit conditions, J_{sm}^{Na} varied from 5 to 7 $\mu\text{mole}/\text{cm}^2$ per hr and averaged 6.1 $\mu\text{mole}/\text{cm}^2$ per hr. This value does not differ significantly from the value for ${}_0J_d^{Na}$ of 4.9 ± 0.9 $\mu\text{mole}/\text{cm}^2$ per hr. This agreement corroborates the view that most if not all of the Na flux from serosa to mucosa takes place through the extracellular pathway and that there is little or no transcellular contribution to this "back-flux." Since the unidirectional flux of Na from the cell interior to the mucosal solution across the brush border is quite large (e.g. $J_{mc}^{Na} - J_{net}^{Na} = 13 - 2 = 11$ $\mu\text{moles}/\text{cm}^2$ per hr) (see Fig. 7 of reference 4), this must mean that there is little or no entry of Na from the serosal solution into the cell across the serosal or lateral membranes. This implies complete, or near-complete, rectification of Na transport across the membrane that appears to be responsible for active Na transport from mucosa to serosa and is consistent with the model presented by Clarkson (17) and the more recent conclusions of Civan (18) for the case of isolated toad urinary bladder.

Indeed, the picture that emerges from these studies closely resembles the dual-pathway model for rat ileum proposed by Clarkson (17). According to that model, the epithelium can be described in terms of two parallel pathways: one that permits only passive transport of ions and another that permits only active ion transport. The passive pathway *behaves as if* it consists of water-filled channels lined with negative fixed charges and was assigned an extracellular location. The transference numbers of Na and Cl *across the entire tissue* in Clarkson's studies were 0.51 and 0.44, respectively; these values are in good agreement with the transference numbers of Na and Cl *in the shunt pathway alone*, derived from the present studies, of 0.60 and 0.34, respectively. The principle difference between the present model and that suggested by Clarkson is that we propose that the two parallel transepithelial pathways consist of a transcellular pathway and an extracellular pathway. The latter is restricted to ionic diffusion (and convection), whereas the former may feature diffusional as well as nondiffusional (e.g. carrier-mediated, active transport, etc.) transport processes. However, because of the relatively high conductance of the extracellular pathway, transepithelial ionic diffusion will be dominated by movements through this channel and will overshadow diffusion through the transcellular pathway. In the limiting case when the resistance to ion diffusion across *either* the mucosal *or* the serosal membrane is infinite, the present model is identical with that proposed by Clarkson. As discussed above, this, to a first approximation, appears to be the case for transmural Na transport.

Transepithelial Electrical Potential Differences

With few possible exceptions (19), all epithelial tissues that are involved in the net transport of ions and water are characterized by "spontaneous" trans-

epithelial electrical potential differences even when both surfaces of the tissue are bathed with solutions having identical compositions. There is abundant evidence that these PDs are somehow related to the processes responsible for transmural ion and water transport, and inhibition of these processes by means of ion replacements, metabolic inhibitors, or ouabain abolishes the PD. However, the precise origins of these PDs have proved to be elusive and represent one of the more perplexing problems in membrane physiology. Unfortunately, the results of this and of previous studies do not permit a clear resolution of this problem for the case of rabbit ileum but instead provide some insight into the complexities that confound this issue.

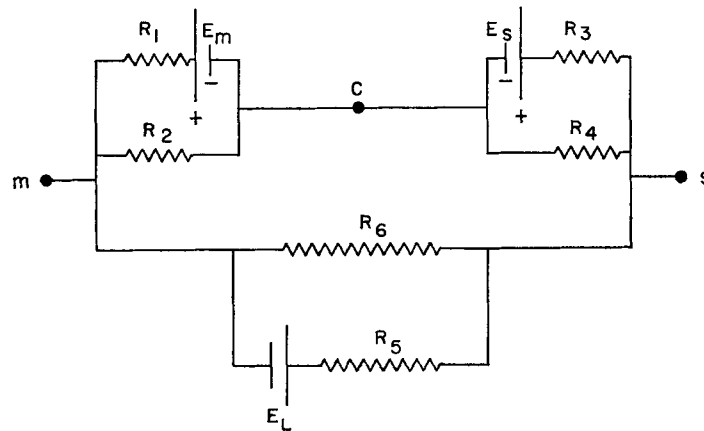

FIGURE 12. Equivalent electrical circuit for rabbit ileum proposed by Rose and Schultz (1). E_m , E_s , and E_L designate electromotive forces operating across the mucosal membrane, serosal membrane, and shunt pathway, respectively; R_1 , R_2 , and R_3 are the internal resistances of these batteries, and R_2 , R_4 , and R_6 are the shunt resistances across the mucosal membrane, serosal membrane, and the extracellular pathway; m , c , and s designate the mucosal, intracellular, and serosal compartments, respectively.

The influence of high conductance shunt pathways on transepithelial PDs can be readily analyzed in terms of the equivalent electrical circuit model for rabbit ileum, recently proposed by Rose and Schultz (1), that is illustrated in Fig. 12. This model differs from that described by Boulpaep (20) for renal tubular epithelium only in that provision is made for the generation of diffusion potentials in the shunt pathway through the inclusion of E_L (the electromotive force operating across the shunt pathway). According to this model

$$\Psi_{ms} = [(E_s R_s - E_m R_m) R_5 R_L / R_6] + E_L R_L (R_1 R_m + R_3 R_s) / R_6 \quad (4)$$

where

$$\begin{aligned} R_m &= R_2 / (R_1 + R_2) \\ R_s &= R_4 / (R_3 + R_4) \\ R_L &= R_6 / (R_5 + R_6) \end{aligned}$$

and

$$R_i = R_1R_m + R_3R_s + R_5R_L.$$

According to equation 4, a transmural PD can arise from a difference between E_mR_m and E_sR_s (note that both R_m and R_s are unitless and must have values between zero and unity) and/or from E_L . In the presence of a low resistance extracellular shunt $R_5R_L \ll (R_1R_m + R_3R_s)$, so that $(E_mR_m - E_sR_s)$ is markedly attenuated and E_LR_L is only slightly affected. Clearly, when $R_5R_L \ll (R_1R_m + R_3R_s)$, Ψ_{m_s} will be dominated by E_LR_L . As $R_5R_L/(R_1R_m + R_3R_s)$ approaches zero, Ψ_{m_s} approaches E_LR_L , and when R_5 approaches zero, Ψ_{m_s} will approach zero regardless of the magnitudes of the electromotive forces in the system. Clearly, the finding of a low or "negligible" spontaneous Ψ_{m_s} across an epithelial tissue sheds no light on the magnitudes of, or difference between, E_m and E_s . Further, small changes in Ψ_{m_s} can be the result of profound changes in E_m and/or E_s and cannot be safely ignored. For rabbit ileum, the present data indicate that

$$\Psi_{m_s} \cong 0.15 (E_mR_m - E_sR_s) + 0.85 E_LR_L. \quad (5)$$

If the above considerations and the interpretation of the present data are correct, diffusion potentials across the tissue should closely correspond to diffusion potentials generated in the shunt pathway, E_LR_L , whereas the contributions of changes in E_m (or E_s) to the transmural PD should be sharply attenuated.

Diffusion potentials across biological membranes that are permeable to Na, K, and Cl are most frequently described by the Goldman-Hodgkin-Katz (21, 22) equation. The applicability of this equation to the present data will be discussed further below. Thus, for the shunt pathway, we may write⁴

$$E_LR_L = - \frac{RT}{\mathcal{F}} \ln \frac{P_K[K]_m + P_{Na}[Na]_m + P_{Cl}[Cl]_s}{P_K[K]_s + P_{Na}[Na]_s + P_{Cl}[Cl]_m}. \quad (6)$$

This equation was originally derived assuming that (a) the ion concentrations within the membrane at both interfaces are directly proportional to those in the adjacent solutions (i.e. constant partition coefficients), (b) ionic mobilities remain constant within the membrane, and (c) electrical field is constant throughout the membrane. Under these conditions, the ionic permeabilities are constant, independent of external solution conditions, and are related to the product of the partition coefficient and the ionic mobility. Patlak (23) has derived equation 6 more generally from the Ussing flux-ratio equation,

⁴ Generally, equation 6 is expressed in terms of ionic activities rather than concentrations. However, in view of the fact that the P_i 's are defined by equation 3 in terms of ion concentrations, these coefficients include the effects of nonideal behavior. The dependence of activity coefficients on concentration over the range 10–150 mM is not sufficient to result in a statistically significant dependence of P_i on $[i]$.

without the above assumptions, where the P_i 's are the unidirectional rate constants at given external concentrations and transmural potential difference. However, the conditions under which these rate constants are independent of external concentration and electrical potential were not defined. As shown by Sandblom and Eisenman (24), with one exception (see below) constancy of the ionic permeability ratios (e.g. P_K/P_{Na} and P_{Cl}/P_{Na}), when ions of both signs are permeable, depends upon the mechanism of ion permeation. Thus, conditions for constancy cannot be deduced from the Ussing equation, which does not specify permeation mechanism or membrane structure (see Appendix). As shown in Fig. 11, the theoretical curves calculated from equation 6 using the permeabilities given in Table I (solid lines in Fig. 11) provide an adequate description of transepithelial diffusion potentials under conditions in which (a) Na was replaced by K with total ion concentration in the mucosal solution maintained constant and equal to that in the serosal solution, and (b) NaCl was replaced by mannitol with a decrease in total ion concentration in the mucosal solution. The dashed lines in Fig. 11 were calculated using a P_{Na} of 0.034 cm/hr and provide a somewhat better fit to the data; this value does not differ significantly from that given in Table I (0.035 cm/hr).

The implications of these observations with regard to the mechanism of ion permeation through the shunt pathway will be discussed below. At this point, it is important to note that the agreement illustrated in Fig. 11 provides strong, independent support for (a) the validity of our approach to the determination of the partial ionic conductances of the shunt pathway and (b) the adequacy of the equivalent electrical circuit model. That is, the shunt conductances determined from the effect of an imposed electric field on the unidirectional influxes in the absence of concentration differences adequately predict transepithelial diffusion potentials in the absence of an external current; it would be difficult to attribute this internal consistency to happenstance. Further, the observation that transepithelial diffusion potentials can be attributed largely to the properties of the shunt pathway provides an explanation for the empirical observations that diffusion potentials across several other epithelial tissues (11, 12, 25) are independent of the direction of the concentration gradients (i.e., diffusion potentials resulting from changes in the composition of the mucosal solution are equal and opposite to those resulting from identical changes in the serosal solution). This, in general, would not be expected if diffusion potentials generated across the mucosal and serosal membranes, separated by an intracellular compartment, contributed significantly to transepithelial diffusion potentials (24). Recently, Barry and Diamond (26) have noted that the gall bladder behaves as if it were a "single membrane," with respect to diffusion potentials, rather than as two membranes arranged in series. These authors raised the possibility that high-conductance tight junctions might constitute the principle diffusion pathway.

The present results provide direct evidence for this view.⁵ (See Addendum.)

In summary: these data strongly suggest that diffusion potentials across low resistance epithelial tissues characterized by high-conductance, extracellular, transepithelial pathways are attributable predominantly to the conductance properties of the shunt pathway and are only minimally influenced by electromotive forces generated across the mucosal and serosal membranes of the epithelial cell. Therefore, the results of such studies do not reflect ionic flows *across* cell membranes but, rather, may be largely attributed to ionic flows through extracellular pathways; these results provide little insight into the properties of cell membranes as they pertain to transmembrane ionic movements. Speculations regarding the ionic permeability properties of cell membranes based on diffusion potentials should be reevaluated in the light of these considerations. Further, it is quite likely that the same reservations complicate the interpretation of electrical potentials that accompany transmural volume flow (e.g., streaming potentials) (11, 27).

Finally, the finding that transmural ionic concentration differences generate an electromotive force in the shunt pathway complicates the interpretation of microelectrode studies of transmembrane electrical potential differences. For example, according to the model illustrated in Fig. 12,

$$\Psi_{mc} = [-(R_s R_e + R_s R_L) E_m R_m - (E_s R_e - E_L R_L) R_i R_m] / R_i.$$

Thus, a change in Ψ_{mc} brought about by a change in the ionic composition of the mucosal solution alone will, in general, reflect changes in E_m and E_L . The interpretation of changes in Ψ_{mc} in terms of ionic permeabilities of the mucosal membrane requires independent knowledge of (a) the ionic conductances of the shunt pathway and (b) the relative resistances of the circuit. Otherwise, effects of E_L on Ψ_{mc} cannot be distinguished from the effects of ion substitution on E_m .

The Anatomic Counterpart of the Shunt Conductance and the Mechanism of Ion Permeation

Extracellular transepithelial pathways in small intestine could be attributed to areas of denudation resulting from spontaneous exfoliation of cells, as has been suggested by Clarkson (17). However, the properties of rabbit ileum closely resemble those of other epithelial tissues that are not uniformly characterized by spontaneous exfoliation of cells, such as fish (12) and rabbit (11)

⁵ Previous studies of diffusion potentials across gall bladder (11, 12) and small intestine (9, 10) have shown that the data can be *fit to* equation 6, yielding a set of constant coefficients; these coefficients are then identified with the ionic permeability ratios. In the present study, *individual* ion permeabilities were determined independently without assumptions regarding concentration or electrical profiles within the barrier; these absolute permeabilities, together with equation 6, describe transepithelial diffusion potentials.

gall bladder, and the proximal renal tubule of *Necturus* (28), rat (19, 29), rabbit (30), and newt (31). All of these tissues are characterized by: (a) a single layer of columnar epithelial cells joined at the apical surface by tight junctions; (b) conspicuous lateral intercellular spaces; (c) low, and often negligible (11, 12, 19), transmural PDs; (d) low transmural resistances; and, (e) in each instance, direct or indirect evidence strongly suggests the presence of low resistance transepithelial shunt pathways. Although shunt pathways have also been implicated in isolated frog skin (32) and toad urinary bladder (33), these tissues have more complex cellular geometries and relatively large transepithelial PDs and resistances.

Thus, although areas of denudation could contribute to shunt pathways in small intestine, they need not be invoked to explain our findings. Instead, the extracellular complex formed by the tight junction and the lateral intercellular space appears to be the most reasonable candidate for the shunt pathways in rabbit ileum and the other epithelial tissues mentioned above. Indeed, several considerations permit a more specific localization of the principle resistive component of this pathway to the tight junctions themselves. First, microscopic studies using visible tracer substances (e.g. hemoglobin [34] and horseradish peroxidase [35]) indicate that the tight junction comprises the functional "seal" that separates the mucosal solution from the lateral intercellular spaces. It is difficult to imagine that the lateral spaces, which are 200–400 Å wide and readily penetrated by macromolecules, could offer significant resistance to the movement of small ions and impose a relative restriction on the permeability to Cl. Second, Tormey et al. (36) have reported that increasing the width of the lateral spaces in rabbit gall bladder above normal does not significantly increase tissue conductance or permeability to small water-soluble molecules; in contrast, obliteration of these spaces decreases conductance. Thus, under normal conditions, the lateral spaces do not appear to constitute the rate-limiting barrier for transepithelial flows.

Although it seems reasonable to conclude that the tight junctions are permeable to small ions (see also reference 28) and water (37), and appear to provide the principle resistive barrier to transmural movement through the extracellular pathway, the mechanism of ion permeation is as yet unsettled. The present results indicate that this pathway is cation selective and imposes a 2.5-fold restriction on Cl permeability compared to that of Na with respect to their mobilities in free solution. Studies on diffusion potentials across other epithelia suggest that the shunt pathways in these tissues are, similarly, more permeable to cations than to anions. This finding is usually attributed to ionic diffusion through water-filled channels lined with fixed negative charges (9–12, 17). However, as discussed by Teorell (38), and more recently by Sandblom and Eisenman (24), the fixed-charge pore model would not, in general, generate diffusion potentials that conform to equation 6. Using a thermodynamic treatment without assumptions regarding concentration and

electrical potential profiles, Sandblom and Eisenman (24) have demonstrated that constancy of ionic permeability ratios requires that the product of the partition coefficient ratios and the mobility ratios be constant. This will be true, in general, only when there is complete co-ion exclusion (e.g. $P_{Cl} = 0$) or when total ionic concentrations on both sides of the membrane are equal. For the case of a thick fixed-charge model, partition into the membrane is generally assumed to be governed by the Donnan ratio (38) and thus would be a function of the total ion concentration in the adjacent solution. Partition into the membrane will be constant only when the total ion concentrations on both sides of the membrane remain constant and equal during replacement of ions (24, 38). However, in the experiments illustrated in Fig. 11, in which NaCl was replaced by mannitol, the partition coefficients would not remain constant and conformity with equation 6 would not be expected unless the ionic mobilities changed in a fortuitous manner so as to maintain constancy of the partition-mobility product.

Thus, the fixed-charge pore model does not appear to satisfy the present data or the results of studies on other epithelial tissues in which conformity with equation 6 was observed. Instead, the observations on rabbit ileum that (a) the permeabilities defined by equation 3 are independent of external concentration, electrical potential, and total ion concentration; (b) these permeabilities together with equation 6 provide an adequate description of transmural diffusion PDs in the face of a significant anion permeability and varying total ionic concentrations; (c) the tissue behaves as an ohmic resistor over the range ± 50 mv (2) and this must reflect the current-voltage properties of the shunt; and (d) the previous observations of Schultz et al. (13) that total tissue conductance varies proportionally with the concentration of permeable ions in the surrounding solutions, are readily accommodated by the model originally envisaged by Goldman (21), and Hodgkin and Katz (22).⁶ Two other permeation mechanisms discussed recently by Eisenman and his coworkers (39, 40) can also be excluded: namely, (a) the ion-exchange membrane which is ruled out by observation (d) above, and (b) ion permeation by means of association with mobile carriers which is ruled out by the conformity with the Ussing flux-ratio equation (see Appendix).

⁶ According to this analysis, the permeability coefficients determined from the "zero-potential" unidirectional fluxes are given by (22)

$$P_i = u_i \beta_i RT/d\bar{c}$$

where u_i = the ionic mobility, β_i = the partition coefficient, and d = thickness of the barrier. As shown by Hodgkin and Katz (22), these permeability coefficients also satisfy the relation

$$J_{\text{net}}^i = P_i ([i]_m - [i]_s)$$

when $\Psi_{ms} = 0$. Thus, P_i defined by equation 3 is consistent with the more usual definition that relates a net flux to a concentration difference.

The picture of ion permeation through the tight junctions that emerges from these considerations involves (a) boundary conditions that are characterized by constant partition coefficients (e.g. partition into a neutral, water-filled pore), (b) constant ionic mobilities, and (c) a constant or near-constant electric field across the diffusion pathway. Cation selectivity of this pathway is not the result of *net, negative fixed charges* but could be attributed to the presence of electronegative groups of fixed dipoles which restrict the partition coefficient and/or mobility of anions. The neutral macrocyclic antibiotics that act as mobile ions carriers (ionophores), with a high selectivity for cations due to the cyclic polyether structure, are excellent examples of biological molecules that exert permselective influences in spite of the fact that they bear no net charge. A *neutral polar pore* of the type suggested by Mueller and Rudin (41) and discussed more recently by Eisenman (40), lined by electronegative groups, could accommodate all of our findings.

Alternatively, the pathway could be lined with dissociated, oppositely charged groups in approximately equal numbers, e.g., carboxylate and amino groups forming the equivalent of a complex of dipolar ions (zwitterions) with no net charge. Alignment of these dipoles so that the negatively charged groups influence the permselective properties of the pathway to a greater extent than do the positively charged groups would satisfy our observations. A neutral pore comprised of dipolar ions would also satisfy the observations that gall bladder (42) and small intestine (27) appear to become anion selective at low pH (about pH 2-3). Indeed, as postulated by Goldman (21), the presence of dipolar ions near their isoelectric point would serve to preserve constancy of the electric field throughout the diffusion pathway. Although the "dipolar ion" model appears to be more consistent with the results of other investigations than the "fixed dipole" model, further study is necessary to distinguish between these alternatives. Suffice it to say that the essential characteristic is *that electroneutrality is maintained by fixed, structural components of the pathway and is not dependent upon the presence of mobile counterions.*

In electron micrographs of epithelial tissues comprised of a single layer of columnar absorptive cells, tight junctions appear as close appositions of the apical portions of the lateral cell membranes with complete obliteration of the intercellular spaces. The length of these junctions in rabbit ileum is approximately 0.5 μ . The over-all width of the junction is less than twice that of the lateral membranes so that the outer portions of these membranes appear to be fused. However, under high magnification the dense central fusion line discloses focal splittings, suggesting regions of defusion and refusion (see Fig. 5 of reference 34). It is intriguing to speculate that these areas of defusion may represent cross-sections of water-filled channels that communicate between the mucosal solution and the lateral spaces. In this respect, it is of interest that the sialic acid containing "glycocalyx" that appears to be largely responsible

for the negative surface charge of cell membranes disclosed by electrophoretic studies (43–45) does not appear to be present in some tight junctions (46–48). Thus, the surface properties of channels through tight junctions need not resemble those of the remainder of the cell membrane.

Spontaneous Transmural PDs

In the absence of actively transported sugars or amino acids, Ψ_{m_s} across rabbit ileum, bathed on both surfaces by a standard electrolyte solution, ranges between 2 and 5 mv, serosa positive. There is abundant evidence that this is somehow related to the rate of active Na transport across the tissue from mucosa to serosa. Although we have no definitive information regarding the origins or magnitudes of $E_m R_m$ or $E_s R_s$, recent studies by Diamond and his coworkers permit some speculation regarding the magnitude and, more important, the orientation of diffusion potentials in the shunt pathway. The standing osmotic gradient hypothesis has gained wide acceptance as the mechanism responsible for isotonic fluid transport by several epithelial tissues including gall bladder, small intestine, and renal proximal tubule (49). According to this model, solute is transported into the apical portions of the lateral intercellular spaces, creating a local region of hypertonicity that provides the driving force for water flow. When the transported solute consists primarily of NaCl, a salt gradient will be established between the lateral spaces and the mucosal solution across the intervening tight junctions. If the permselective properties of the shunt pathway reside in the tight junctions, a diffusion potential should result. The magnitude of this PD for the case of rabbit ileum is uncertain; however, for the present purposes the important point is that *the orientation of this PD would be opposite to the orientation of the spontaneous Ψ_{m_s}* . Indeed, Machen and Diamond (50) have demonstrated that in rabbit gall bladder, where transmural NaCl transport appears to be the result of a neutral, coupled transport mechanism, the spontaneous Ψ_{m_s} is oriented so that the mucosal solution is positive with respect to the serosal solution. These authors concluded that this was due to a diffusion potential between the lateral spaces and the mucosal solution and suggested that the tight junctions might be the permselective pathway. If these speculations are correct, the spontaneous Ψ_{m_s} across rabbit ileum must result from a difference between $E_m R_m$ and $E_s R_s$, and this difference must be of sufficient magnitude to overcome the oppositely oriented electromotive force generated in the shunt pathway. If the NaCl concentration difference across the tight junctions is 20–40 mM, $E_L R_L$ would be 1–2 mv (Fig. 11), mucosa positive, and according to equation 5 ($E_m R_m - E_s R_s$) would have to be 26–40 mv.

These speculations assume concrete importance when we consider the increase in Ψ_{m_s} in the presence of actively transported sugars and amino acids. Rose and Schultz (1) have demonstrated that the addition of sugars or amino

acids to the mucosal solution results in a depolarization of Ψ_{mc} that is much greater than the simultaneously recorded increase in Ψ_{ms} . According to the model shown in Fig. 12, the relation between $\Delta\Psi_{ms}$ and $\Delta\Psi_{mc}$ resulting from a change in E_m alone is given by

$$\Delta\Psi_{ms}/\Delta\Psi_{mc} = 1/(1 + R_3R_s/R_5R_L).$$

Thus, $\Delta\Psi_{ms} < \Delta\Psi_{mc}$ whenever $0 < R_5R_L < \infty$. In nonpoisoned tissues, $\Delta\Psi_{ms}/\Delta\Psi_{mc}$ averaged 0.3 so that R_3R_s would have to be twice R_5R_L to account for these observations on the basis of a change in E_m alone. The present data indicate that R_3R_s is at least five times R_5R_L . Thus, if the effects of sugars or amino acids were restricted to a change in E_m alone, $\Delta\Psi_{ms}/\Delta\Psi_{mc}$ should average only 0.16. Stated in another way, because of the low resistance shunt, the change in E_m resulting from the presence of sugars or amino acids is markedly attenuated and does not appear to be of sufficient magnitude to account for the over-all change in Ψ_{ms} . These considerations, which are based on direct measurements of the resistance of the shunt pathway, support the previous, tentative conclusion based on studies with poisoned tissues (1). In the light of these data, we are forced to conclude that the total effect of sugars or amino acids on Ψ_{ms} is the combined result of (a) a depolarization of E_m due to electrogenic influx of Na coupled to the influxes of sugars or amino acids, and (b) an increase in E_s that is related to an increased rate of active Na transport into the serosal solution and could be attributed to the operation of an electrogenic pump mechanism at the serosal membranes. The over-all ($\Delta E_m R_m - \Delta E_s R_s$) must be of sufficient magnitude to overcome any change in $E_L R_L$ which, according to the above considerations, would be oriented in a direction opposite to the change in Ψ_{ms} .

ADDENDUM

After the completion of this manuscript, a series of papers by Barry, Diamond, and Wright (51-53) appeared containing a detailed theoretical treatment of ion permeation through neutral pores and an extensive analysis of conductances and diffusion potentials across rabbit gall bladder. These authors conclude that: (a) the principle route for ion permeation across gall bladder bypasses the cells and probably resides in the tight junctions, (b) transmural diffusion potentials reflect the permselective properties of this extracellular route, and (c) ion permeation takes place through neutral water-filled pores lined with fixed dipoles oriented such that the electronegative groups determine cation selectivity. Because of time-dependent changes in relative permeabilities, these authors assume that the polar pore is impermeable to anions and that an additional shunt pathway is responsible for the anion conductance. All of the measurements in the present study were performed between 30 and 90 min after dissection, and there is no apparent systematic dependence of P_i on time. Thus, a common route for anions and cations satisfies our observations. With this single

exception, our conclusions are in complete agreement with those arrived at by Barry, Diamond, and Wright.

Unpublished observations by Wright, included in one of these papers (51), indicate that P_K/P_{Na} for rabbit small intestine, determined from diffusion potentials, is approximately unity. This is in agreement with the present data.

APPENDIX

The flux ratio equation states that

$$J_{12}^i/J_{21}^i = (a_1/a_2) \exp [z_i \mathcal{F}(\Psi_1 - \Psi_2)/RT]$$

where the J s are the unidirectional fluxes of i , a designates ionic activity, and the subscripts 1 and 2 designate the two solutions bathing the surfaces of the membrane. The assumptions underlying the derivation of this equation are that: (a) i crosses the membrane by simple ionic diffusion and is unaffected by the flows of other solutes or solvent (this includes interactions between the flows of tracer and the abundant species), (b) diffusion through the membrane is rate limiting so that the distribution across the membrane-solution interfaces may be considered at equilibrium (regardless of the mechanism of partition), (c) the chemical state of i within the membrane is the same as that in the surrounding solutions, (d) the bidirectional fluxes traverse pathways having identical properties, and (e) the steady state is maintained. No further assumptions need be made regarding specific mechanisms of permeation or partition into the membrane.

Thus, when $a_1 = a_2$,

$$J_{\text{net}}^i = J_{12}^i - J_{21}^i = J_{21}^i \{ \exp [z_i \mathcal{F}(\Psi_1 - \Psi_2)/RT] - 1 \}.$$

Previous studies have shown that the total tissue conductance is independent of the transmural PD over the range ± 50 mv (2). Therefore, it is reasonable to assume that the individual ionic conductances are similarly unaffected by the PD over this range. Thus,

$$G_i = z_i \mathcal{F} J_{21}^i \{ \exp [z_i \mathcal{F}(\Psi_1 - \Psi_2)/RT] - 1 \} / (\Psi_1 - \Psi_2),$$

and when $(\Psi_1 - \Psi_2) = 0$

$${}_0G_i = {}_0J_{21}^i (z_i^2 \mathcal{F}^2 / RT),$$

and, equating G_i with ${}_0G_i$, we obtain

$$J_{21}^i / {}_0J_{21}^i = z_i \mathcal{F}(\Psi_1 - \Psi_2) / RT / \{ \exp [z_i \mathcal{F}(\Psi_1 - \Psi_2) / RT] - 1 \}.$$

The right side of the above equation has the form $x/(e^x - 1)$, which may be approximated by $e^{-x/2}$ so that

$$J_{21}^i = {}_0J_{21}^i \exp [z_i \mathcal{F}(\Psi_1 - \Psi_2) / RT]^{-1/2}.$$

A similar expression has been derived by Kimizuka and Koketsu (54).

Thus, the only assumptions underlying the application of equation 1 are those basic to the applicability of the Ussing flux-ratio equation and the assumption of constancy of ionic conductances *over the range of PDs studied*. The latter is supported by these and previous studies (2) on rabbit ileum. Further, the results of Clarkson's studies (17) on rat ileum suggest that interactions between the flow of *i* and the flows of other ions and water (e.g. electro-osmotic phenomena) are sufficiently weak so that errors introduced by ignoring these interactions are second order.

The authors gratefully acknowledge helpful and stimulating discussions of this work with Doctors Jared Diamond and George Eisenman.

This work was supported by research grants from the United States Public Health Service, National Institute of Arthritis and Metabolic Diseases (AM-13744), and the American Heart Association (70-633).

Dr. Frizzell is a United States Public Health Service postdoctoral research fellow (AM-49585) and Dr. Schultz is the recipient of a Research Career Development Award from the National Institute of Arthritis and Metabolic Diseases (AM-9013).

Received for publication 29 July 1971.

BIBLIOGRAPHY

1. ROSE, R. C., and S. G. SCHULTZ. 1971. Studies on the electrical potential profile across rabbit ileum. Effects of sugars and amino acids on transmural and transmucosal P.D.s. *J. Gen. Physiol.* **57**:639.
2. SCHULTZ, S. G., and R. ZALUSKY. 1964. Ion transport in isolated rabbit ileum. I. Short-circuit current and Na fluxes. *J. Gen. Physiol.* **47**:567.
3. SCHULTZ, S. G., R. ZALUSKY, and A. E. GASS, JR. 1964. Ion transport in isolated rabbit ileum. III. Chloride fluxes. *J. Gen. Physiol.* **48**:375.
4. SCHULTZ, S. G., P. F. CURRAN, R. A. CHEZ, and R. E. FUISZ. 1967. Alanine and sodium fluxes across mucosal border of rabbit ileum. *J. Gen. Physiol.* **50**:1241.
5. FRIZZELL, R. A., and S. G. SCHULTZ. 1970. Effects of monovalent cations on the sodium-alanine interaction in rabbit ileum. Implication of anionic groups in sodium binding. *J. Gen. Physiol.* **56**:462.
6. CALDWELL, P. C. 1968. Liquid junction potentials and their effect on potential measurements in biological systems. *Int. Rev. Cytol.* **24**:345.
7. PICKNETT, R. G. 1968. Liquid junction potential between dilute electrolytes and saturated potassium chloride. *Trans. Faraday Soc.* **64**:1059.
8. CURRAN, P. F., S. G. SCHULTZ, R. A. CHEZ, and R. E. FUISZ. 1967. Kinetic relations of the Na-amino acid interaction at the mucosal border of intestine. *J. Gen. Physiol.* **50**:1261.
9. WRIGHT, E. M. 1966. Diffusion potentials across the small intestine. *Nature (London)*. **212**:189.
10. WRIGHT, E. M. 1966. The origin of the glucose dependent increase in the potential difference across the tortoise small intestine. *J. Physiol. (London)*. **185**:486.
11. DIAMOND, J. M., and S. C. HARRISON. 1966. The effect of membrane fixed charges on diffusion potentials and streaming potentials. *J. Physiol. (London)*. **183**:37.
12. DIAMOND, J. M. 1962. The mechanism of solute transport by the gall bladder. *J. Physiol. (London)*. **161**:474.
13. SCHULTZ, S. G., P. F. CURRAN, and E. M. WRIGHT. 1967. Interpretation of hexose-dependent electrical potential differences in small intestine. *Nature (London)*. **214**:509.
14. SCHULTZ, S. G., R. E. FUISZ, and P. F. CURRAN. 1966. Amino acid and sugar transport in rabbit ileum. *J. Gen. Physiol.* **49**:849.
15. ROTUNNO, C. A., F. A. VILALLONGA, M. FERNANDEZ, and M. CEREJIDO. 1970. The penetration of sodium into the epithelium of the frog skin. *J. Gen. Physiol.* **55**:716.

16. BIBER, T. U. L., and P. F. CURRAN. 1970. Direct measurement of uptake of sodium at the outer surface of the frog skin. *J. Gen. Physiol.* **56**:83.
17. CLARKSON, T. W. 1967. The transport of salt and water across isolated rat ileum. Evidence for at least two distinct pathways. *J. Gen. Physiol.* **50**:695.
18. CIVAN, M. M. 1970. Effects of active sodium transport on current-voltage relationship of toad bladder. *Amer. J. Physiol.* **219**:234.
19. FRÖMTER, E., and U. HEGEL. 1966. Transtubulare Potentialdifferenzen an proximalen und distalen Tubuli der Ratteniere. *Pfluegers Arch. Gesamte Physiol. Menschen Tiere.* **291**:107.
20. BOULPAEP, E. L. 1967. Ion permeability of the peritubular and luminal membrane of the renal tubular cell. In *Symposium über Transport und Funktion Interzellulare Elektrolyte*. F. Kruck, editor. Urban and Schwarzenberg, Munich, Germany. 98.
21. GOLDMAN, D. E. 1943. Potential, impedance, and rectification in membranes. *J. Gen. Physiol.* **27**:37.
22. HODGKIN, A. L., and B. KATZ. 1949. The effect of sodium ions on the electrical activity of the giant axon of the squid. *J. Physiol. (London)*. **108**:37.
23. PATLAK, C. S. 1960. Derivation of an equation for the diffusion potential. *Nature (London)*. **188**:944.
24. SANDBLOM, J. P., and G. EISENMAN. 1967. Membrane potentials at zero current. The significance of a constant ionic permeability ratio. *Biophys. J.* **7**:217.
25. BALLIEN, M., and E. SCHOFFENIELS. 1961. Origine des potentiels bioélectriques de l'épithélium intestinal de la tortue grecque. *Biochim. Biophys. Acta.* **53**:537.
26. BARRY, P. H., and J. M. DIAMOND. 1970. Junction potentials, electrode standard potentials, and other problems in interpreting electrical properties of membranes. *J. Membrane Biol.* **3**:93.
27. SMYTH, D. H., and E. M. WRIGHT. 1966. Streaming potentials in the rat small intestine. *J. Physiol. (London)*. **182**:591.
28. WINDHAGER, E. E., E. L. BOULPAEP, and G. GIEBISCH. 1966. Electrophysiological studies on single nephrons. *Proc. Int. Congr. Nephrol. 3rd.* **1**:35.
29. HEGEL, U., E. FRÖMTER, and T. WICK. 1967. Der elektrische Wandwiderstand des proximalen Konvolutes der Ratteniere. *Pfluegers Arch. Gesamte Physiol. Menschen Tiere.* **294**:274.
30. BURG, M. B., and J. ORLOFF. 1970. Electrical potential difference across proximal convoluted tubules. *Amer. J. Physiol.* **219**:1714.
31. HOSHI, T., and F. SAKAI. 1967. A comparison of the electrical resistances of the surface cell membrane and cellular wall in the proximal tubule of the newt kidney. *Jap. J. Physiol.* **17**:627.
32. USSING, H. H., and E. E. WINDHAGER. 1964. Nature of shunt path and active transport path through frog skin epithelium. *Acta Physiol. Scand.* **61**:484.
33. CIVAN, M. M., O. KEDEM, and A. LEAF. 1966. Effect of vasopressin on toad bladder under conditions of zero net sodium transport. *Amer. J. Physiol.* **211**:569.
34. FARQUHAR, M. G., and G. E. PALADE. 1963. Junctional complexes in various epithelia. *J. Cell Biol.* **17**:375.
35. BENTZEL, C. J., D. R. TOURVILLE, B. PARSAR, and T. B. TOMASI, JR. 1971. Bidirectional transport of horseradish peroxidase in proximal tubule of *Necturus* kidney. *J. Cell Biol.* **48**:197.
35. TORMEY, J. MCD., A. P. SMULDERS, and E. M. WRIGHT. 1971. A common pathway for active and passive water and solute fluxes across gall bladder epithelium. *Fed. Proc.* **30**(2):422. (Abstr.)
37. BENTZEL, C. J., B. PARSAR, and D. K. HARE. 1969. Osmotic flow across proximal tubule of *Necturus*. Correlation of physiologic and anatomic studies. *Amer. J. Physiol.* **217**:570.
38. TEORELL, T. 1953. Transport processes and electrical phenomena in ionic membranes. *Prog. Biophys. Biophys. Chem.* **3**:305.
39. EISENMAN, G., J. P. SANDBLOM, and J. T. WALKER JR. 1967. Membrane structure and ion permeation. *Science (Washington)*. **155**:965.
40. EISENMAN, G. 1968. Ion permeation of cell membranes and its models. *Fed. Proc.* **27**:1249.
41. MUELLER, P., and D. O. RUDIN. 1967. Development of $K^+ - Na^+$ discrimination in

- experimental bimolecular lipid membranes by macrocyclic antibiotics. *Biochem. Biophys. Res. Commun.* **26**:398.
42. WRIGHT, E. M., and J. M. DIAMOND. 1968. Effects of pH and polyvalent cations on the selective permeability of gall bladder epithelium to monovalent ions. *Biochim. Biophys. Acta.* **163**:57.
 43. COOK, G. M. W., D. H. HEARD, and G. V. F. SEAMAN. 1961. Sialic acids and the electrokinetic charge of the human erythrocyte. *Nature (London)*. **191**:44.
 44. SIMON-REUSS, I., G. M. W. COOK, G. V. F. SEAMAN, and D. H. HEARD. 1964. Electrophoretic studies on some types of mammalian tissue cells. *Cancer Res.* **24**:2038.
 45. AMBROSE, E. J. 1965. Cell Electrophoresis. J. and A. Churchill Ltd., London.
 46. BENEDETTI, E. L., and P. EMMELOT. 1968. Structure and function of plasma membranes isolated from liver. In *Ultrastructure in Biological Systems*. A. J. Dalton and F. Haguenau, editors. Academic Press, Inc., New York. **4**:33.
 47. RAMBOURG, A. 1966. Electron microscope detection of a carbohydrate-rich cell coat at the surface of rat cells. *J. Cell Biol.* **31**:89A. (Abstr.)
 48. RAMBOURG, A., and C. P. LEBLOND. 1967. Electron microscope observations on the carbohydrate-rich cell coat present at the surface of cells in the rat. *J. Cell Biol.* **32**:27.
 49. DIAMOND, J. M., and W. H. BOSSERT. 1967. Standing-gradient osmotic flow. A mechanism for coupling water and solute transport in epithelia. *J. Gen. Physiol.* **50**:2061.
 50. MACHEN, T. E., and J. M. DIAMOND. 1969. An estimate of the salt concentration in the lateral intercellular spaces of rabbit gall bladder during maximal fluid transport. *J. Membrane Biol.* **1**:194.
 51. BARRY, P. H., and J. M. DIAMOND. 1971. A theory of ion permeation through membranes with fixed neutral sites. *J. Membrane Biol.* **4**:295.
 52. WRIGHT, E. M., P. H. BARRY, and J. M. DIAMOND. 1971. The mechanism of cation permeation in rabbit gallbladder. Conductances, the current-voltage relation, the concentration dependence of anion-cation discrimination, and the calcium competition effect. *J. Membrane Biol.* **4**:331.
 53. BARRY, P. H., J. M. DIAMOND, and E. M. WRIGHT. 1971. The mechanism of cation permeation in rabbit gallbladder. Dilution potentials and biionic potentials. *J. Membrane Biol.* **4**:358.
 54. KIMIZUKA, H., and K. KOKETSU. 1964. Ion transport through cell membrane. *J. Theor. Biol.* **6**:290.