

# IOT based water level and quality monitoring system in overhead tanks

Dr. K. Raghava Rao <sup>1</sup>, Sanagala Srinija <sup>2</sup>\*, Kukkala Hima Bindu <sup>2</sup>, D. Satish Kumar <sup>3</sup>

<sup>1</sup> Professor, Department of ECSE, KLEF, Guntur, AP.

<sup>2</sup> Student, Fourth year, Department of ECSE, KLEF, Guntur, AP.

<sup>3</sup> Asst. Professor, KLEF, Guntur, AP.

\*Corresponding author E-mail: [srinijasrinivas26@gmail.com](mailto:srinijasrinivas26@gmail.com)

## Abstract

Water is most profitable and valuable source since it is the fundamental need of all the individuals. Now a day we are facing many issues regarding water wastage and quality monitoring in tanks. This paper proposes a proficient method to water level and quality observing in the overhead tanks to lessen the present water wastage and give better water quality. The venture is about overhead tank checking framework that is we screen the level of water in the overhead tank and furthermore we decide nature of water. Firstly, we have the issue of filling the tanks which are situated far, and for this we have executed a little hypothesis that we put level sensors in the tank, that level sensors detect the water level in the tank and sends us message about water level in the tank. Also, the second preferred standpoint is that really, we utilize different quality parameter sensors like pH and turbidity sensors to screen the water quality in the tank. In light of level of water, we can choose how much measure of water is required for specific area and give adequate measure of water as opposed to squandering water. The Raspberry Pi B+ is utilized as core controller. The composed framework applies to an IOT module for getting to sensor information from center controller to cloud. The sensor information can be seen on cloud. At last information will be assembled and through Wi-Fi information can be seen on versatile device through android app. Based on data in the app workers will be sent to clean the tank This proposed framework is a minimal effort, wireless, multi-sensor arrange for exact water monitoring in tanks.

**Keywords:** Water Monitoring; Raspberry Pi; Ultrasonic Sensor; Turbidity Sensor; Ph Sensor; Cloud Computing; Internet of Things, Android App.

## 1. Introduction

Water has gained an inestimable value in the recent past. This scenario arises mainly because of the various faces. Population, ageing infrastructure, dilapidated technologies and ground water contamination have been the fore-runners of the many challenges that water faces. These challenges have pushed drinking water to an extent where it has become an amenity rather than utility. This phenomenon of scanty drinking water demands a methodology which is both achievable and efficient. One such process is the over-head tank and quality monitor system. In this process a group of tanks situated in locality are considered as an entity. An ultrasonic sensor is used to detect the water level of the tank and to monitor the quality a pH-sensor and turbidity sensor are used. Observing the level of water in the tank we can regulate the amount of water that locality is using. Through this observation we could send extra amount of water to that locality if the demand is more or consequently curb the amount of water if the supply is more to avoid wastage of drinking water. Quality parameters help in purity check. If in case the results show the water is impure and turbid the information through the module is sent to the municipal department which employs workers to take sanitary measures of cleaning the tank so the water could regain its purity. The data from the sensor is collected and Smart water tank executes IoT, with which, the client can specifically screen and control the working of tank through the cell phone and from wherever in this world. The android application is made with the goal that the information assembled from the cloud is sent to app. From applica-

tion civil division can send workers to clean the tank in view of the area. This paper is organized in the following ways. Chapter 2 centers around the current thoughts that are already been implemented. Chapter 3 focuses on the fundamental ideas utilized as a part of usage of this work. Chapter 4 centers around system blueprint and its execution with all sub units. Chapter 5 and 6 is related to the data spill out of sensors and application around database in cloud.

## 2. Existing systems

An In 2016, Divya Kaur displayed a paper on "IoT based Water Tank Control framework "for avoid the water wastage. Making a control framework to naturally control the water pump requires cautious perception of what individuals do as their day by day movement to make beyond any doubt that the tank is full. In nearly all over India each state has a State Water Supply body which is capable for advancement and control of water supply in state. Due to shortage of water the discharge of water is controlled and done at certain time(s) in a day. So this paper is pointed at displaying the venture in implanting a control framework into an programmed control framework into an programmed water level controller utilizing wi-fi module [1].

In 2015, N Vijayakumar and R Ramya present a "Design and advancement of a moo taken a toll framework for genuine time monitoring of the water quality in IoT (web of things)". The framework comprises distinctive sensors like pH ,turbidity,water level sensors etc. All the parameters are measured and that measured esteem

which is put away from sensors can be processed by Raspberry PI B+. The sensor information can be appeared on web by utilizing cloud computing and this gadgets are more efficient, low taken a toll, and competent of processing, sending operation through Wi-Fi module to portable phones. This can implement for environment monitoring and the information can be seen any place in the world [2].

In 2013 Saima Maqbool, Nidhi Chandra displayed a paper on "Real Time Remote Checking and Control of Water Systems utilizing Zigbee 802.15.4" in which the engineering which comprises a number of components likes water quality sensor water level sensor, GSM modem, PC, XBee, and a database. Sensor hubs are performing the specific function or work, sense the information and that information are transmitted to the conclusion device or machine by means of inverter. Detected information is coordinated by arrange types of gear like Switch. [3] Router will assemble information from the conclusion apparatus like XBees which in turn from sensors and sends the information to facilitator. In the computer all data are displayed. In the Computer; waterway level, bore water level and bore water level is appeared by utilizing C sharp program. From computer specific errand can be executed like "SMS" is sent to user's framework and at alert are blows at the wanted level. All this information can be kept and spared in database which will be utilized to actualize a "water master."

In 2015, Thinagaran Perumal, Md Nasir Sulaiman, Leong displayed "Web of Things (IoT) Empowered Water System". They executed "water observing framework utilizing IOT" for genuine time situation. This determination is of moo fetched which includes framework of coordinates tangible that licenses inward perception for quality of water. Utilizing Web, significant and warning information are exchanged to a cloud server and these information can be gotten by client terminal which are possessed by consumers. The water measurement's conclusion result is appeared on cloud. A Thingspeak as a portion of caution framework is integrated too. This sort of organization can be utilized reasonably successfully by private clients as by mechanical clients or more water utilities. By utilizing Web of Things, this sort of organization can allow early caution framework for convenient water quality.

In 2012, Made Saraswati, Endrowednes Kauntama, Pono Mardjoko displayed a paper on "Design and Development of Water Level Administration framework available Through SMS". This framework utilizes ultrasonic sensor which calculates the level of water without any contact to water. For the information processor, the microcontroller is utilized and controller to other electronic components. In this framework, SMS (Brief Message Benefit) is utilized to report the estimation. The major aim of this investigation is to actualize or create a such sort of organization that can calculate the water level using microcontroller consequently. As a SMS, all these comes about of estimation can be sent to the cell phone of client at every ask. This sort of organization can reorganize with numerous estimations location, as long as the beginning setting by SMS agreeing to the establishment to each estimation location was done.

In 2016, B. Dhivyapriya, C. Gulabsha, S. P. Maniprabha, G. Kandasamy, Dr. V. Chandrasekaran GSM based water tank level monitoring and pump control system. In which a new technique is proposed to continuously keeps track of the level of water in water systems like overhead water tanks. The user can send the message to the system to know the water level details of the tank and also be used to regulate the pump spontaneously by turning OFF the pump when the critical level of water in tank is reached and send the message to the user that the water in the tank is full. This is aimed to control the level of water with support of ultrasonic sensor and GSM technology.

### 3. Proposed system

Block Diagram:

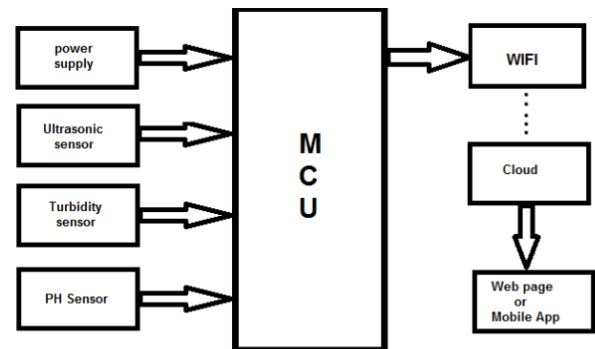

#### 3.1. Sensor systems

##### a) Ultrasonic Sensor:

Ultrasonic sensor is utilized to produce ultrasonic sound waves which are besieged on the surface of water. This sensor comprises of a speaker which discharges a ultrasonic sound wave and a mic which recognizes that specific sound wave. As we have actualized the ultrasonic sensor, there is no contact of water with sensor which guarantees long existence of the sensor.

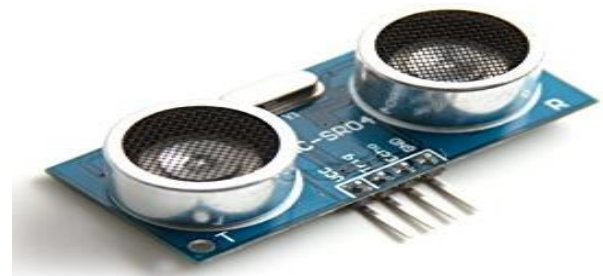

Fig. 1: Ultrasonic Sensor.

##### b) Turbidity Sensor:

Turbidity is the shadiness of a fluid caused by broad amounts of individual particles that are generally imperceptible to the stripped eye, similar to smoke in air. Turbidity can be assessed particularly with a turbidity meter/sensor. The turbidity demonstrates the degree at which water loses its straightforwardness. Turbidity is caused by particles and shaded material in water. It can be assessed regarding water clearness, or direct with a turbidity instrument, for instance, a turbidity meter or turbidity sensor



Fig. 2: Turbidity Sensor Module.

#### 3.2. Water monitoring

##### a) Core Controller - Raspberry pi:

Raspberry pi is a single board computer and the cheapest chip used by students and experts for various project. The data that is equipped from the sensor is analogy data. This analog data can't be read by the controller, so data should be converted to digital. Raspberry pi converts the sensor data from analog to digital using ADC convertor. Raspberry pi acts as interface between sensor and cloud environment. We can also use NODE MCU, Arduino but

they don't have any inbuilt wi-fi modules and other features raspberry pi possess. Also, raspberry pi is a high-speed processor and has many advantages.

**Table 1:** Ultrasonic Sensor Specifications

Parameters	Values
Working voltage	DC 5V
Working current	15Ma
Working frequency	40Hz
Maximum range	4m
Minimum range	2m
Measuring angle	15 DEGREE
Tigger input signal	10 μS TTL
Outline dimension	45*20*15 mm

**Table 2:** Specifications of Turbidity Sensor

Parameters	Values
Range	1-50 ntu and 0-1000 ntu
Accuracy	±1%
Meter resolution	12 bit
Operating voltage	10-36
Current drawn	30ma
Warm up time	5 seconds
Maximum pressure	30psi
Weight	1lb
Size of body	1 ½ x8.5 inch
Operating temperature	14°C-122°C

### 3.3. Applications

a) Cloud environment – ThingSpeak:  
 ThingSpeak is a cloud stage giving distinctive organizations just engaged to building IoT applications. ThingSpeak offers the limits of envisioning the assembled data as diagrams, constant data aggregation, relational association, ability to make modules and applications for collaborating with web organizations. The data from controller is sent into thingspeak. This cloud datsa is continuously monitored for regular intervals of time and graphs will be generated for corresponding sensors.

b) App development – Android App development:  
 This is a programming platform designed to help the programmers for developing and testing android applications. We have created our application in this software. In this app, the client need to set the maximum and minimum values of water level in the tank. The current water level in tank is displayed in the app. Also, the client need to set the turbidity values to determine the quality of the tank. The current turbidity value is displayed on the app. Based on that value workers are sent to clean the tank.

### 4. Methodology

Water is one of the most important basic need for living beings, yet it is wasted. In this system we are going to check the water quality in the tank along with the water level. Water quality is also equally important. After some days water in the tank will be contaminated by dry leaves and dust. In the present system we initially connect the ultrasonic sensor to the core controller and place it on the top of the tank. Ultrasonic sensor is reasonably-priced sensor offers 2cm to 400cm of non-touch size capability with a ranging accuracy which can attain as much as 3mm. pH sensor determines the amount of alkalinity present in the water pH range should always be between 0-14 for any liquid. If pH value ranges from 0-6.9 then it is acidic. If pH is between 6.9-7.9 the liquid is neither acidic nor basic and can use for household purposes. The pH sensor will include a traditional glass electrode as these electrodes are extra reliable and cost effective for long time monitoring. The glass membrane at the bottom is doped to be ion-selective and is handiest touchy to a specific ion. The pH electrode acts like a single cellular battery and there's a direct correlation between the voltage output of the electrode and the pH of the measured water. The turbidity indicates the degree at which water loses its transparency.

**Table 3:** PH Sensor Specifications

Parameters	Values
POWER	5.00V
SIZE	43mmX32mm
RANGE	0-14PH
TEMPERATURE	0-60 °C
ACCURECY	±0.1 PH 25° C
POWER INDICATOR	LED
CABLE LENGTH FROM SENSOR	660 mm
RESPONSE TIME	≤1min

The data from the cloud is sent into the android app. The android app is created using android app is developed according to the system. In the app, we initially set the values up to which tank must be filled. Client also fix some maximum and minimum values of the turbidity. The current values of the tank must be displayed in the app. Based on the values displayed on the app if the tank is not clean then app track the location of the tank using google maps. After tracking the location, alert message will be displayed so that workers will be sent to the location to clean the tanks. Using the above method, we can clearly monitor the tanks effectively and prevent the wastage of water and store decent quality of water. This system is easy and cost effective.

### 5. Flow chart representation

Flowchart is the diagrammatic representation of the system that gives the explanation of the process that is going to take place in the system. Initially in the app we give the maximum and minimum values of the sensor. Based on those values the app should notice that notify the status of the tank with respect to level and quality. Also, the app notifies the current value of the tank.

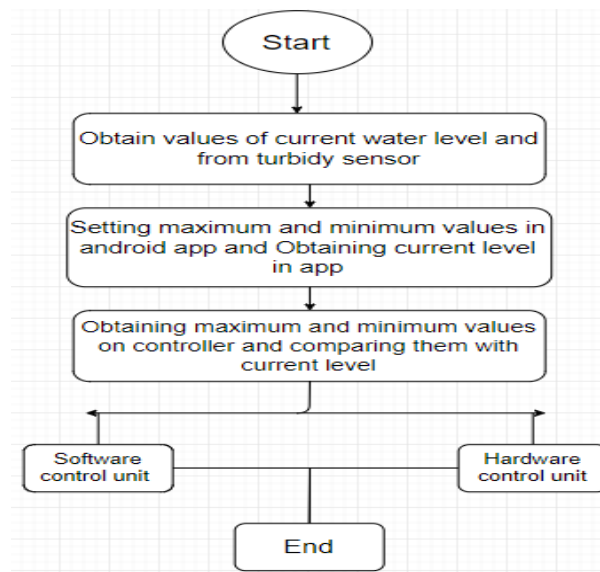

**Fig. 3:** Overall Flowchart of System.

The app will display the status the tank. Based on the value of app if the current value is less than the minimum value then there will be notification displayed on the app that tank is clean and water level in percentage. If the current level is greater than the maximum value then notification should appear such that there is tank should be cleaned so please send the workers from the concern department to clean the tank. If current value is in between the minimum and maximum value then the notification should be sent such that current value should be displayed on the app

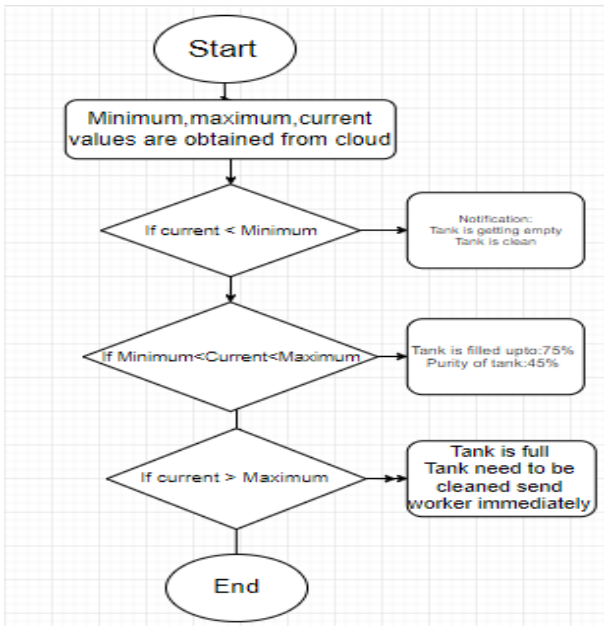

Fig. 4: Flowchart of Logic in App.

### 6. Results

We collect the received data from the sensor that is from both ultrasonic and turbidity sensor. The data we collected from the sensor is stored in cloud. Using thingspeak we collect the data in regular intervals of time and analyze it using the waveforms obtained. After analysis, this data is sent into app. So that we can track out the location of the tank and clean or on/off the tank. We require exact location of the tank based on the latitude and longitude point so the people will be sent appropriately to clean the tank. In app three things are clearly monitored. If the tank is full or not, for long time no need to send extra data else data tank is that location needs more water if empty. Based on turbidity data, we can determine whether tank is clean or not, if the tank is clean then app should show that tank clean, if not then we need to check the exact location of where tank and display it in app so that workers will be sent to clean tank.

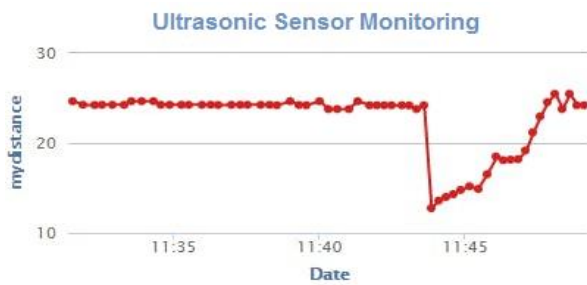

Fig. 5: Ultrasonic Sensor Readings Obtained in Cloud.

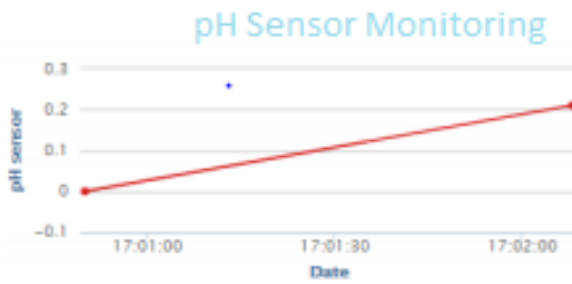

Fig. 6: Ph Sensor Readings Obtained in Cloud.

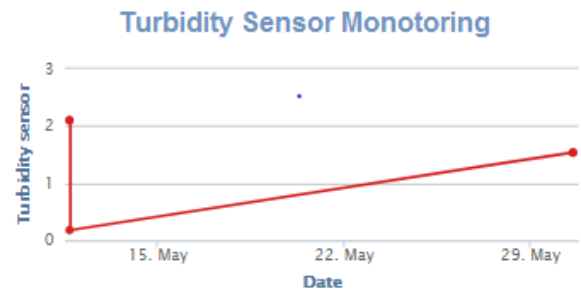

Fig. 7: Turbidity Sensor Readings Obtained in Cloud.



Fig. 8: Webpage Displaying the Current Readings.

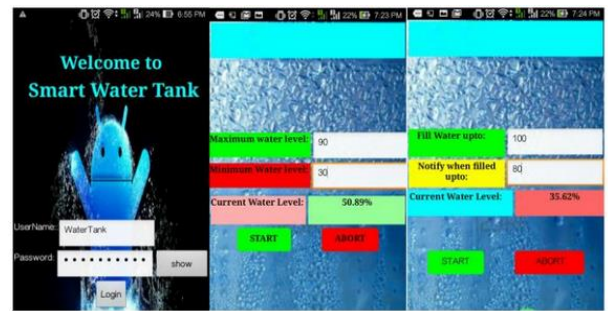

Fig. 9: Screenshots of Android App.

### 7. Conclusion

Water is one of the maximum crucial simple desires for all dwelling beings. in step with Wikipedia, 97% water is present in Seas and Oceans. meaning simplest three% of available water is gift as sparkling water. Out of this three%, handiest 1% of water is to be had for consumption. but unluckily a massive quantity of water is being wasted due to out of control use and exploitation of water aid. some different automated water stage monitoring structures also are gift, however to date most of the techniques have a few shortcomings in practice. We attempted to triumph over those troubles and implemented an green automated water degree tracking and controlling system. Our intension of this studies paintings changed into to establish a flexible, economical, clean configurable and most significantly, a transportable device which can clear up our water wastage trouble. We've used Raspberry pi, Ultrasonic sensor, Turbidity sensor and pH sensor which reduces value effectively and makes this project economical. Additionally, this venture doesn't require unique exclusive tank for it, current water tanks may be used.

### Acknowledgement

We are forever grateful to Mayor, Vijayawada and the municipal commission members for their continuous support for doing the project. Also, we are thankful to Koneru Lakshmaiah Educational Foundation for their guidance and support to this project.

## References

- [1] DivyaKura,IOT based water tank control"[Article-Embedded for you ]Jan/Feb 2016.
- [2] N Vijaya Kumar, R Ramayas, "The real time monitoring of water quality in IOT environment", IEEE sponsored 2<sup>nd</sup> international conference on innovations in information, embedded and communication systems (Iciiecs) 2015.
- [3] Saima Maqbool , Nidhi Chandra, "Real time wire less monitoring and control of water system using zigbee 802.15.14' 5<sup>th</sup> international conference on computational intelligence and communication networks, 2013.
- [4] thinagaran perumall, md nasir sulaiman , leong intenet of things(IOT) enabled water system , IEEE 4<sup>th</sup> gobal conference on consumer electronic (GCCE), 2015.
- [5] Made Saraswathi , EndrowednesKauntama, PonoMardjoko, Design and Construction of Water Level Management System Accessible Through SMS, IEEE Computer Society, 201299.
- [6] B. Dhivyapriya, C. Gulabsha, S. P. Maniprabha, G. kandaswamy, Dr. Chandhrasekharan, Gsm Based Water Tank Level Monitoring and Pump control system ,2016 Ijarmate.
- [7] Parchet Varma, Akshya Kumar, NiheshRathod ,prathik jain malikarjun s.renu subramaniam, Bhardhwaj Amrutur,M,S.mohan kumar , Rajesh Sundresan,IOT Based Water management system for a campus IEEE,IEEE First international Smart cities conference (isc2), 2015.
- [8] Asaad Ahmed mohammedahmed ELTAIEB,Zhang Jian min"Automatic Water Level Control System", international journal of scaince and research (IJSR) 2013.
- [9] SanamPudasiaini, Anuj prathik, sukrtiDhakal, Milan Paudel ,"automatic Water Level Controller with Short Messaging Service (SMS)notification " ,International journal of science and recerch publications, Volume 4,Issue 9, Septmber 2014 1, ISSN2250-3153.
- [10] Jaytibhatt, jigneshpatoliya,IOT based water quality monitoring system, proceecings of 49<sup>th</sup> IRF international Conference , 21<sup>st</sup> February 2016 ,pune, india , ISBN: 978-93-85973-46-8.
- [11] In 2013, Raghavendhra. R.M.Uttara Kumari, S.A. Hariprasad presented a paper on "implemenationof Simulated Water Level Cntroler", International Journal of Advanced Reserch in Computer Science and Software Enginnering.