

Is There a Cell-Biological Alphabet for Simple Forms of Learning?

Robert D. Hawkins and Eric R. Kandel

Center for Neurobiology and Behavior,
Columbia University, and the New York State Psychiatric Institute

Recent studies indicate that the cellular mechanism underlying classical conditioning of the *Aplysia* siphon withdrawal reflex is an extension of the mechanism underlying sensitization. This finding suggests that the mechanisms of yet higher forms of learning may similarly be based on the mechanisms of these simple forms of learning. We illustrate this hypothesis by showing how several higher order features of classical conditioning, including generalization, extinction, second-order conditioning, blocking, and the effect of contingency, can be accounted for by combinations of the cellular processes that underlie habituation, sensitization, and classical conditioning in *Aplysia*.

Learning has traditionally been divided into two major categories: associative learning, which includes classical and operant conditioning, and nonassociative learning, which includes habituation and sensitization (see Hilgard & Marquis, 1940; Mackintosh, 1974). A central problem in the study of learning has been to discover how these different forms of learning are related to one another. Specifically, is each form of learning governed by a fundamentally different mechanism, or are they governed by variations on a common mechanism? During the past two decades there has been substantial progress in identifying the cellular mechanisms for habituation, sensitization, and conditioning in simple vertebrate systems and in higher invertebrates such as *Aplysia*, *Drosophila*, *Hermisenda*, locust, and crayfish (Alkon, 1979; Byers, Davis, & Kiger, 1981; Castellucci, Pinsker, Kupfermann, & Kandel, 1970; Crow & Alkon, 1980; Duerr &

Quinn, 1982; Hawkins, Abrams, Carew, & Kandel, 1983; Hoyle, 1979; Kandel & Schwartz, 1982; Krasne, 1969; Spencer, Thompson, & Nielson, 1966; Zucker, 1972). On the basis of these studies, one can begin to specify several common mechanistic features in these different forms of learning. These general features can be summarized as follows:

1. Elementary aspects of learning are not diffusely distributed in the brain but can be localized to the activity of specific nerve cells.
2. Learning produces alterations in the membrane properties and in the synaptic connections of those cells.
3. The changes in synaptic connections so far encountered have not involved formation of totally new synaptic contacts. Rather, they are achieved by modulating the amount of chemical transmitter released by presynaptic terminals of neurons.
4. In several instances the molecular mechanisms of learning involve intracellular second messengers and modulation of specific ion channels.

Moreover, recent results in both *Aplysia* and *Drosophila* indicate that the molecular mechanism of conditioning, an associative form of learning, is an elaboration of the same molecular mechanism involved in sensitization, a nonassociative form of learning (Duerr & Quinn, 1982; Hawkins et al., 1983). The finding that unifying cell-biological principles may underlie both nonassociative and associative forms of learning raises another question: Do

Preparation of this article was supported in part by grants from the National Institute of Mental Health (MH26212), National Institute of General Medical Services (GM-32099), and Office of Naval Research (83-K-0166).

We are grateful to Tom Abrams, Tom Carew, Greg Clark, Ruth Colwill, Robert Rescorla, and Alan Wagner for their comments on an earlier draft of this article, to Kathrin Hilten and Louise Katz for preparing the figures, and to Harriet Ayers and Charlotte Alexander for preparing the manuscript.

Requests for reprints should be sent to Robert D. Hawkins, Center for Neurobiology and Behavior, College of Physicians & Surgeons, Columbia University, 722 West 168th Street, New York, New York 10032.

the mechanisms so far encountered represent the beginning of an elementary cellular alphabet of learning? That is, can these units be combined to yield progressively more complex learning processes? In this article we suggest that such an alphabet exists and that certain higher order forms of learning generally associated with cognition can be explained in cellular-connectionistic terms by combinations of a few relatively simple types of neuronal processes.

A particularly interesting focus for exploring a possible cellular alphabet for learning is the analysis of higher order features of classical conditioning. These features provide an important bridge between the experimental study of conditioning, which has been largely carried out in animals, and cognitive psychology, which until recently has been primarily concerned with human mentation. Furthermore, some of these higher order features (second-order conditioning, blocking, and an unconditioned stimulus [US] preexposure effect) have been shown to occur in conditioning of a terrestrial mollusc, *Limax maximus* (Sahley, Rudy, & Gelperin, 1981), and recent experiments suggest that another feature (the effect of contingency) occurs in *Aplysia* (Hawkins, Carew, & Kandel, 1983). It therefore may be possible to apply a cellular analysis to these aspects of conditioning in invertebrates.

Our purpose in this brief theoretical review is to illustrate that several higher order features of classical conditioning can be derived from our current understanding of the cellular mechanisms of habituation, sensitization, and classical conditioning. Studies by Kamin, Rescorla, Wagner, Mackintosh, and others have shown that these higher order features of conditioning appear to involve cognition in the sense that the animal's behavior depends on a comparison of current sensory input with an internal representation of the world (Dickinson & Mackintosh, 1978; Kamin, 1969; Rescorla, 1978; Wagner, 1978). Our goal is thus to suggest how cognitive psychology may begin to converge with neurobiology to yield a new perspective in the study of learning. The perspective we suggest is similar in some ways to that of Hull (1943), who attempted 40 years ago to explain a variety of complex forms of learning in terms of principles derived from simpler forms of learning. Our perspective dif-

fers from that of Hull, however, in that his system was based on postulates inferred from behavior, whereas our approach is based on directly observable cellular processes. We believe that a cell-biological approach to the rules of learning may be more fruitful, because it attempts to explain higher level phenomena (behavior) in terms of more basic phenomena (cell biology) and thus avoids some of the circularity inherent in a purely behavioral approach. Our approach also differs from that of theoreticians who have attempted to explain behavioral phenomena in terms of hypothetical neural elements (e.g., Hebb, 1949; Rosenblatt, 1962; Sutton & Barto, 1981) in that we have based our thinking on known neural mechanisms.

To illustrate these points, we divide this article into two parts. In the first part, which is empirical, we briefly review research on the cellular mechanisms of two forms of nonassociative learning and one form of associative learning in *Aplysia*, and suggest how these mechanisms form the outline of a cellular alphabet of learning. In the second part, which is theoretical, we show how this alphabet might be used to account for several higher order features of classical conditioning in *Aplysia* and in other animals. Although these proposals are speculative and may not turn out to be correct, we hope that they will at least provide a useful framework for further investigations into the neuronal basis of learning.

Three Forms of Learning in *Aplysia* Have Common Cellular Features

Studies of learning in *Aplysia* have focused on the defensive withdrawal reflexes of the external organs of the mantle cavity. In *Aplysia* and in other molluscs, the mantle cavity, a respiratory chamber housing the gill, is covered by a protective sheet, the mantle shelf, which terminates in a fleshy spout, the siphon. When the siphon or mantle shelf is stimulated by touch, the siphon, mantle shelf, and gill all contract vigorously and withdraw into the mantle cavity. This reflex is analogous to vertebrate defensive escape and withdrawal responses, which can be modified by experience. Unlike vertebrate withdrawal reflexes, however, the *Aplysia* withdrawal reflex is partly monosynaptic—siphon sensory neurons syn-

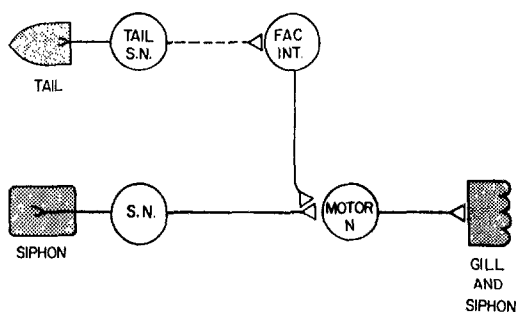

Figure 1. Partial neuronal circuit for the *Aplysia* gill- and siphon-withdrawal reflex and its modification by tail stimulation. (Mechanosensory neurons [S.N.] from the siphon make direct excitatory synaptic connections onto gill and siphon motor neurons. Tail sensory neurons excite facilitator interneurons, which produce presynaptic facilitation of the siphon sensory neurons. Tail stimulation also produces excitation of gill and siphon motor neurons through pathways not shown in Figure 1.)

apse directly on gill and siphon motor neurons (Figure 1). Nonetheless, this simple reflex can be modified by two forms of nonassociative learning, habituation and sensitization, as well as by a form of associative learning, classical conditioning.

Habituation

In habituation, perhaps the simplest form of learning, an animal learns to ignore a weak stimulus that is repeatedly presented when the consequences of the stimulus are neither noxious nor rewarding. Thus, an *Aplysia* initially responds to a tactile stimulus to the siphon by briskly withdrawing its gill and siphon. But with repeated exposure to the stimulus, the animal exhibits reflex responses that are reduced to a fraction of their initial value. Habituation can last from minutes to weeks, depending on the number and pattern of stimulations (Carew, Pinsker, & Kandel, 1972; Pinsker, Kupfermann, Castellucci, & Kandel, 1970).

At the cellular level, the short-term (minutes to hours) form of habituation involves a depression of transmitter release at the synapses that the siphon sensory neurons make on gill and siphon motor neurons and interneurons (Castellucci & Kandel, 1974; Castellucci et al., 1970). This depression involves, at least in part, a decrease in the amount of Ca^{++} that flows into the terminals of the sen-

sory neurons with each action potential (Figure 2, Part A). Because Ca^{++} influx determines how much transmitter is released, a decrease in Ca^{++} influx results in decreased release (Klein, Shapiro, & Kandel, 1980). Long-term habituation appears to involve changes at the same locus, because it is accompanied by a decrease in the number and size of active zones (specialized areas where transmitter is released) at sensory neuron synapses (Bailey & Chen, 1983).

Sensitization

Sensitization is a somewhat more complex form of nonassociative learning in which an animal learns to strengthen its defensive reflexes and to respond vigorously to a variety of previously weak or neutral stimuli after it has been exposed to a potentially threatening or noxious stimulus. Thus, if a noxious sensitizing stimulus is presented to the neck or tail, the siphon- and gill-withdrawal reflexes are enhanced, as are inking, walking, and other defensive behaviors (Pinsker et al., 1970; Walters, Carew, & Kandel, 1981). This enhancement persists from minutes to weeks depending on the number and intensity of the sensitizing stimuli (Pinsker, Hening, Carew, & Kandel, 1973). Sensitization not only enhances normal (naive) reflex responses, but it enhances previously habituated reflex responses. On the cellular level, dishabituation of a previously habituated response by a noxious stimulus has been shown to be a special case of sensitization (Carew, Castellucci, & Kandel, 1971; Spencer et al., 1966).

The short-term (minutes to hours) form of sensitization involves the same cellular locus as habituation, the synapses that the sensory neurons make on their central target cells, and again the learning process involves an alteration in transmitter release—in this case an enhancement in the amount released (Castellucci & Kandel, 1976; Castellucci et al., 1970). But sensitization uses more complex molecular machinery. This machinery has at least five steps (see Figures 1 and 2, Part B): (a) Stimulating the tail activates a group of facilitator neurons that synapse on or near the terminals of the sensory neurons and act there to enhance transmitter release. This process is called *presynaptic facilitation*. (b) The transmitter released by the facilitator neurons,

which is presumed to be serotonin or a related amine, activates an adenylate cyclase that increases the level of free cyclic AMP in the terminals of the sensory neurons. (c) Elevation of free cyclic AMP, in turn, activates a second enzyme, a cAMP-dependent protein kinase. (d) The kinase acts by means of protein phosphorylation to close a particular type of K^+ channel and thereby decreases the total number of K^+ channels that are open during the action potential. (e) A decrease in K^+ current leads to broadening of subsequent action potentials, which allows a greater amount of Ca^{++} to flow into the terminal and thus enhances transmitter release (Bailey, Hawkins, & Chen, 1983; Bernier, Castellucci, Kandel, & Schwartz, 1982; Castellucci, Nairn, Greenard, Schwartz, & Kandel, 1982; Hawkins, 1981a, 1981b; Hawkins, Castellucci, & Kandel, 1981b; Kandel & Schwartz, 1982; Kistler,

Hawkins, Koester, Kandel, & Schwartz, 1983; Klein & Kandel, 1980; Siegelbaum, Camardo, & Kandel, 1982). Long-term sensitization appears to involve changes at the same locus, because it is accompanied by an increase in the number and size of active zones at sensory neuron synapses (Bailey & Chen, 1983). Kandel and Schwartz (1982) speculate that an increase in cAMP levels may trigger these long-term changes in the sensory neurons in parallel with the short-term changes.

Classical Conditioning

Classical conditioning resembles sensitization in that the response to a stimulus to one pathway is enhanced by activity in another. Typically, in classical conditioning an initially weak or ineffective conditioned stimulus (CS) becomes highly effective in producing a be-

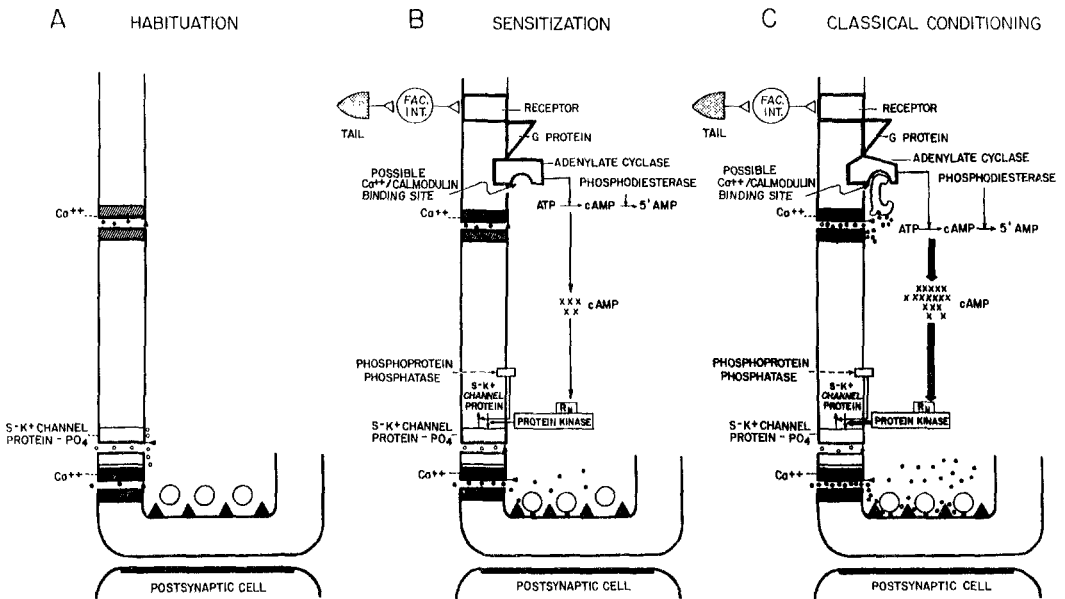

Figure 2. Cellular mechanisms of habituation, sensitization, and classical conditioning of the *Aplysia* gill-and siphon-withdrawal reflex. *Part A.* Habituation. (Repeated stimulation of a siphon sensory neuron, the presynaptic cell in the figure, produces prolonged inactivation of Ca^{++} channels in that neuron [represented by the closed gates], leading to a decrease in Ca^{++} influx during each action potential and decreased transmitter release.) *Part B.* Sensitization. (Stimulation of the tail produces prolonged inactivation of K^+ channels in the siphon sensory neuron through a sequence of steps involving cAMP and protein phosphorylation [see the text for details]. Closing these K^+ channels produces broadening of subsequent action potentials, which in turn produces an increase in Ca^{++} influx and increased transmitter release.) *Part C.* Classical conditioning. (Tail stimulation produces amplified facilitation of transmitter release from the siphon sensory neuron if the tail stimulation is preceded by action potentials in the sensory neuron. This effect may be due to priming of the adenyl cyclase by Ca^{++} that enters the sensory neuron during the action potentials, so that the cyclase produces more cAMP when it is activated by the tail stimulation.)

havioral response after it has been paired temporally with a strong US.¹ Often a reflex can be modified by both sensitization and classical conditioning. In such cases, the response enhancement produced by classical conditioning (paired presentation of the CS and US) is greater and/or lasts longer than the enhancement produced by sensitization (presentation of the US alone). Moreover, whereas the consequences of sensitization are broad and affect defensive responses to a range of stimuli, the effects of classical conditioning are specific and enhance only responses to stimuli that are paired with the US.

In conditioning of the *Aplysia* withdrawal response, the US is a strong shock to the tail that produces a powerful set of defensive responses; the CS is a weak stimulus to the siphon that produces a feeble response. After repeated pairing of the CS and US, the CS becomes more effective and elicits a strong gill- and siphon-withdrawal reflex. Enhancement of this reflex is acquired within 15 trials, is retained for days, extinguishes with repeated presentation of the CS alone, and recovers with rest (Carew, Walters, & Kandel, 1981). The siphon-withdrawal reflex can also be differentially conditioned using stimuli to the siphon and mantle shelf as the discriminative stimuli. Animals in which a CS⁺ to the siphon has been paired with a tail shock and a CS⁻ to the mantle has been presented unpaired with the tail shock, show a greater response to siphon than to mantle stimulation when tested after training. The converse is true when a stimulus to the mantle has been paired, and one to the siphon has been presented unpaired with the tail shock. Using this differential procedure, we have found that a single training trial is sufficient to produce significant learning, and that the learning becomes progressively more robust with more training trials (Carew, Hawkins, & Kandel, 1983).

In many instances of conditioning in vertebrates, learning depends critically on the time between presentation of the CS and US, or the interstimulus interval (ISI). To examine the temporal specificity of conditioning of the withdrawal reflex, we varied the ISI in different groups of animals (Hawkins, Carew, & Kandel, 1983). Significant conditioning occurred when the onset of the CS preceded the onset of the US by 0.5 s, and marginally significant con-

ditioning resulted when the interval between the CS and the US was extended to 1.0 s. In contrast, no significant learning occurred when the CS preceded the US by 2 or more s, when the two stimuli were simultaneous, or, in backward conditioning, when US onset preceded the CS by 0.5 or more s. Thus, conditioning in *Aplysia* resembles conditioning in vertebrates in having a steep ISI function, with optimal learning when the CS precedes the US by approximately 0.5 s (e.g., Gormezano, 1972).

What cellular processes give classical conditioning this characteristic temporal specificity? We have found that classical conditioning of the withdrawal reflex involves a pairing-specific enhancement of presynaptic facilitation (Hawkins et al., 1983). In classical conditioning, because the CS precedes the US, the sensory neurons of the CS pathway are set into activity and fire action potentials just before the facilitator neurons of the US pathway become active. Using a reduced preparation, we have found that if action potentials are generated in a sensory neuron just before the US is delivered, the US produces substantially more facilitation of the synaptic potential from the sensory neuron to a motor neuron than if the US is not paired with activity in the sensory neuron. Pairing spike activity in a sensory neuron with the US also produces greater broadening of the action potential in the sensory neuron than does unpaired stimulation, indicating that the enhancement of facilitation occurs presynaptically. Thus, at least some aspects of the mechanism for the temporal specificity of classical conditioning occur within

¹ We do not distinguish between the appearance of new responses and the strengthening of preexisting responses because we think this difference is not fundamental. Rather, we believe that the neural connections for most or all possible stimulus-response associations are prewired, and training merely alters the strengths of those connections, in some cases bringing the response from below threshold to above threshold. Support for this view comes from experiments in which neural activity is recorded in various regions of the brain during conditioning. For example, at the beginning of an eye-blink-conditioning experiment there is usually no overt response to the auditory conditioned stimulus, but there is a detectable response in the motor nucleus controlling eye blink (e.g., Cegavske, Patterson, & Thompson, 1979). Training strengthens this preexisting neural response until it is above threshold for producing an observable behavioral response.

the sensory neuron itself. We have called this type of enhancement *activity-dependent amplification of presynaptic facilitation* (Hawkins et al., 1983). Similar cellular results have been obtained independently by Walters and Byrne (1983), who have found activity-dependent synaptic facilitation in identified sensory neurons that innervate the tail of *Aplysia*. By contrast, Carew, Hawkins, Abrams, and Kandel (in press) have found that a different type of synaptic plasticity first postulated by Hebb (1949), which has often been thought to underlie learning, does *not* occur at the sensory neuron-motor neuron synapses in the siphon-withdrawal circuit.

These experiments indicate that a mechanism of classical conditioning of the withdrawal reflex is an elaboration of the mechanism of sensitization of the reflex: presynaptic facilitation caused by an increase in action potential duration and Ca^{++} influx in the sensory neurons. The pairing specificity characteristic of classical conditioning results because the presynaptic facilitation is augmented or amplified by temporally paired spike activity in the sensory neurons. We do not yet know which aspect of the action potential in a sensory neuron interacts with the process of presynaptic facilitation to amplify it, nor which step in the biochemical cascade leading to presynaptic facilitation is sensitive to the action potential. As a working hypothesis, Hawkins et al. (1983) proposed that the influx of Ca^{++} with each action potential provides the signal for activity and that it interacts with the serotonin-sensitive adenylate cyclase in the terminals of the sensory neuron so that the cyclase produces more cAMP in response to serotonin (Figure 2, Part C). Recent experiments have supported this hypothesis. Thus, brief application of serotonin to the sensory cells can substitute for tail shock as the US in the cellular experiments, and Ca^{++} must be present in the external medium for paired spike activity to enhance the effect of the serotonin (Abrams, Carew, Hawkins, & Kandel, 1983). Furthermore, serotonin produces a greater increase in cAMP levels in siphon sensory cells if it is preceded by spike activity in the sensory cells than if it is not (Kandel et al., 1983; see also Ocorr, Walters, & Byrne, 1983, for a similar result in *Aplysia* tail sensory neurons).

Is There a Cellular Alphabet for Learning?

The finding that the molecular mechanism of conditioning of the withdrawal reflex appears to be an extension of the mechanism of sensitization suggests two hypotheses about the mechanisms of yet higher forms of learning. These hypotheses assume that learning is not a unitary process, but a family of related processes that range from habituation to insight learning, with conditioning occupying an intermediate position. First, we propose that higher forms of learning may utilize the mechanisms of lower forms of learning as a general rule, and second, we speculate that this may occur because the mechanisms of higher forms of learning have evolved from those of lower forms of learning. It is easy to imagine how the cellular mechanism of conditioning in *Aplysia* might have evolved from the mechanism of sensitization. For example, a small change in the adenyl cyclase might have made it sensitive to Ca^{++} that enters the cell during an action potential, thus giving rise to the activity dependence of facilitation. This example suggests that the mechanisms of yet higher forms of learning may similarly have evolved from the mechanism of conditioning. Higher forms of learning may also use the mechanisms of lower forms of learning within an individual animal. Thus, whereas single neurons may possess only a few fundamental types of plasticity which are used in all forms of learning, combining the neurons in large numbers with specific synaptic connections (as occurs for example in mammalian cortex) may produce the much more subtle and varied processes required for more advanced types of learning.

We illustrate this idea at an elementary level by showing how some of the higher order features of classical conditioning might be generated by small systems of neurons utilizing known types of synaptic plasticity. For the most part, our proposals are simply attempts to translate into neuronal terms ideas that have been proposed at an abstract level by experimental psychologists. In this, we are particularly indebted to the theories of conditioning of Rescorla and Wagner. As an exercise, we have arbitrarily restricted ourselves to the use of physiological processes and neuronal connections that are known to occur in the neural

circuit underlying the *Aplysia* gill- and siphon-withdrawal reflex. We should emphasize, however, that some of the higher order behavioral phenomena discussed have not yet been tested in *Aplysia*. Our arguments on these points are therefore entirely speculative and are simply meant to illustrate an initial approach to the problem of relating cognitive processes to neuronal events.

Several Higher Order Features of Classical Conditioning Can Be Derived From the Cellular Mechanisms of Simpler Forms of Learning

Classical conditioning has two attractive features that account for its central role in the analysis of learning. The first is that in acquiring a conditioned response, an animal learns a fundamental relationship about the environment: that the CS predicts and may appear to cause the US. Second, classical conditioning is accompanied by several higher order effects. Some of these were first described by Pavlov and the early students of associative learning; others have more recently been described by Kamin, Rescorla, Wagner, and others who have been interested in the cognitive or information-processing aspects of learning. According to this cognitive view, the animal builds an image of the external world, compares the image of the world with reality—with the view of the world as validated by current sensory information—and then modifies its behavior accordingly.

In light of the evidence for a cellular relationship between habituation, sensitization, and classical conditioning, it becomes interesting to examine the possibility that a general cellular alphabet exists for a wide variety of learning processes. Can combinations of the elementary mechanisms used in habituation, sensitization, and conditioning account for additional higher order aspects of associative learning without requiring additional cellular mechanisms? Here we consider five higher order features: (a) stimulus specificity and generalization, (b) extinction and spontaneous recovery, (c) second-order conditioning, (d) blocking, and (e) degeneration of learning by intermittent presentation of US alone or US preexposure. The explanations that we propose

for these phenomena are not meant to be exclusive. Rather, we wish only to indicate how simple cellular processes such as synaptic depression and facilitation can be used in different combinatorial ways to contribute to these higher order features of behavior.

Stimulus Specificity and Generalization

Animals learn to respond to the conditioned stimulus and not to other irrelevant stimuli. Activity-dependent enhancement of presynaptic facilitation readily confers this stimulus specificity (Figure 3): Only those sensory neurons that are active preceding the US undergo the amplified form of presynaptic facilitation, and thus only the response to the paired conditioned stimulus is selectively enhanced (see also Carew et al., 1983; Hawkins et al., 1983).

Stimulus specificity is not generally complete, however. After conditioning, animals respond to stimuli other than the conditioned stimulus, and the strength of their response depends on the degree of similarity between the test stimulus and the conditioned stimulus. We suggest two cellular explanations for stimulus generalization. The first is sensitization: An aversive unconditioned stimulus produces some enhancement of defensive responses to *all* stimuli, whether they are paired with it or not. This enhancement is simply greater for the paired stimuli. The second explanation (which is basically similar to those proposed by Atkinson & Estes, 1963, and Bush & Mosteller, 1951) is that there will be some overlap in the sensory neurons and interneurons excited by different stimuli. Thus, conditioning of one stimulus produces amplified presynaptic facilitation of some (but not all) of the neurons that are excited by a second stimulus, and therefore produces partial enhancement of the response to the second stimulus. The greater the similarity between the stimuli, the more overlap there is in the neurons they excite, and consequently, the more generalization. This mechanism can account for a wider range of generalization if activity-dependent amplification of presynaptic facilitation occurs not only at sensory neurons but also at interneurons. We believe that this is likely to be true, because we have no reason to think that the sensory neurons are unique in this regard.

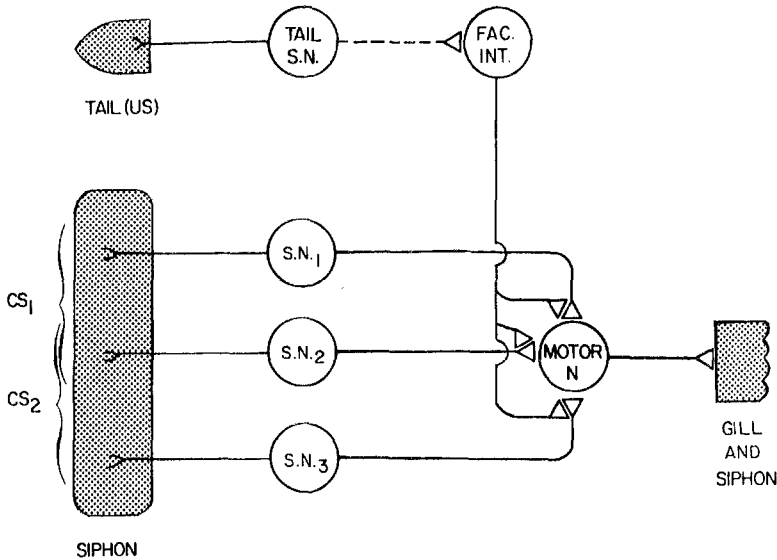

Figure 3. Proposed cellular mechanisms of stimulus specificity and generalization. (CS₁ excites siphon sensory neurons 1 and 2, and CS₂ excites neurons 2 and 3. Only those sensory neurons that are active preceding the US undergo the amplified form of presynaptic facilitation. Thus, conditioning of CS₁ produces partial, but not complete, generalization to CS₂.)

Extinction and Spontaneous Recovery

The conditioned response can be eliminated by extinction: If the CS is presented repeatedly without reinforcement by the US, the response to the CS gradually diminishes and eventually disappears. Extinction, however, does not return an animal to its naive state. A number of experimental procedures can restore or reinstate an animal's response to the conditioned stimulus. For example, if the CS is not presented for some time following extinction, the animal's response to the CS recovers, either partially or completely, thereby indicating that the animal remembers the original training.

We suggest that extinction and spontaneous recovery represent, at least in part, an interaction between habituation and classical conditioning. Thus, after the CS pathway has been classically conditioned, it can still undergo habituation due to synaptic depression of the input from the CS to the motor neurons. Because habituation has a different neuronal mechanism than does classical conditioning, its time course could be dramatically different. For example, if the CS is presented only a few times during extinction, the habituation produced would wear off rapidly. As a result, as the habituation (extinction) faded, learning

would again become manifest (spontaneous recovery) in the response of the CS pathway (Figure 4).

Another procedure that reverses the effects of extinction is the presentation of a strong extraneous stimulus. Pavlov (1927) referred to this phenomenon as disinhibition, because he thought that extinction was due to inhibition that the extraneous stimulus removed. Because the characteristics of disinhibiting stimuli are

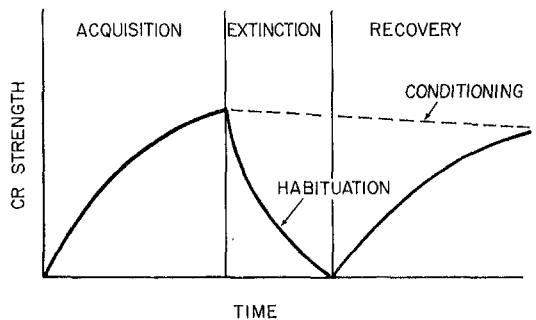

Figure 4. Proposed cellular mechanisms of extinction and spontaneous recovery. (Repeated presentation of the conditioned stimulus [CS] during extinction produces habituation of the response to that CS, and the response recovers with rest. These processes are superimposed on the memory for the conditioning, the dashed line.)

similar to those of sensitizing stimuli, however, we would argue that disinhibition is simply due to sensitization, as has been shown for dishabituation (Carew et al., 1971; Groves & Thompson, 1970; Spencer et al., 1966). There are several other parallels between extinction and habituation. For example, both processes generally occur faster with a shorter ITI, and both occur more rapidly if the training is repeated after a period of rest (Pavlov, 1927; Thompson & Spencer, 1966). These similarities support the idea that extinction has the same neuronal mechanism as habituation, which in *Aplysia* is synaptic depression.

Second-Order Conditioning

Second-order conditioning is the process whereby events that formerly did not reinforce behavior become reinforcing. In the first stage of a second-order conditioning experiment, an effective US is used to reinforce and thereby

strengthen the response to an initially ineffective CS₁ by pairing the two stimuli (CS₁-US). After such pairing, CS₁ itself can now serve as a reinforcing stimulus to strengthen the response to a new conditioned stimulus, CS₂, if those two stimuli are paired (CS₂-CS₁). Second-order conditioning is thought to be ubiquitous in everyday life and to bridge the gap between laboratory experiments and complex natural behavior, which often does not have obvious reinforcers. Second-order conditioning also illustrates the interchangeability of the CS and the US, because the same stimulus can serve as either a CS or a US in a conditioning experiment.

Before considering a possible cellular mechanism of second-order conditioning, we must introduce three additional features of the neural circuitry of *Aplysia* that we believe may be general and that are important for the arguments that follow (Figure 5). First, in addition to the US, many CS inputs excite the

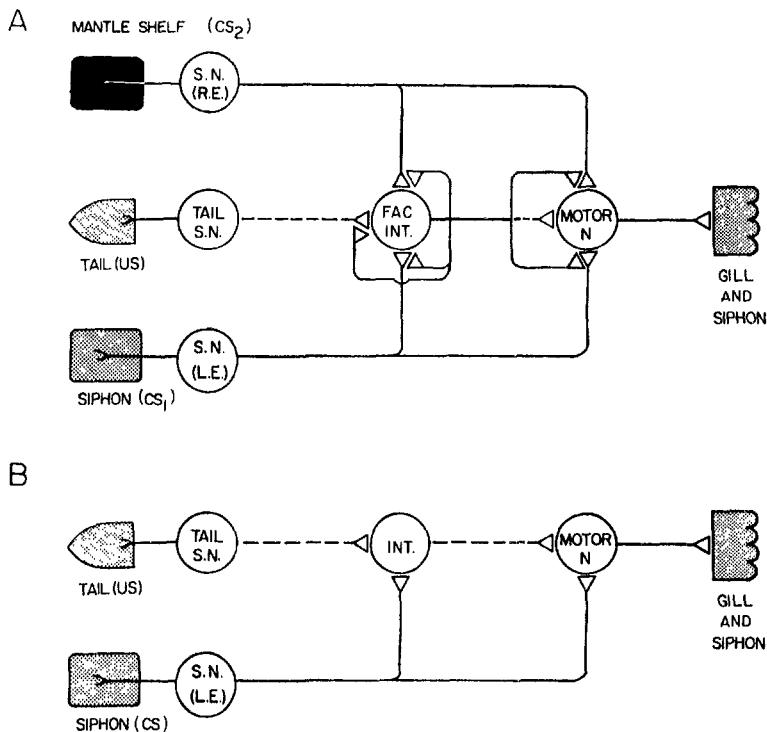

Figure 5. More complete neuronal circuit for the gill- and siphon-withdrawal reflex and its modification by tail stimulation. Part A. Circuit for differential conditioning of responses to stimulation of the siphon and mantle shelf. (The siphon is innervated by the LE cluster of sensory neurons and the mantle is innervated by the RE cluster.) Part B. Simplified version of Part A, illustrating possible neural representations of S-R and S-S learning (see the text).

facilitator neurons. Thus, the facilitator neurons may be thought of as a local arousal system (for earlier discussion of this point see Hawkins & Advocat, 1977; Kandel, 1978). Second, the facilitator neurons produce facilitation not only at the synapses from the sensory neurons to the motor neurons but also at the synapses from the sensory neurons to many interneurons, *including the synapses from the sensory neurons to the facilitator neurons themselves*. This fact has the interesting consequence that the sensory-facilitator synapses (unlike the sensory-motor synapses) should act like Hebb synapses. That is, firing a sensory neuron just before firing the facilitator should produce selective strengthening of the synapse from that sensory neuron to the facilitator (compared to other inputs onto the facilitator) because of activity-dependent enhancement of the facilitation. Third, the facilitator neurons also excite gill and siphon motor neurons, either directly or indirectly (Hawkins, Castellucci, & Kandel, 1981a).

Figure 5, Part A, illustrates how our model of conditioning could account for second-order effects. Once a particular pathway, for example, the siphon, is paired repeatedly with an unconditioned stimulus (to the tail), the CS pathway from the siphon becomes effective in producing a much stronger gill contraction. Moreover, activity-dependent enhancement of presynaptic facilitation occurs not only at the sensory-motor synapse but also at the sensory-facilitator synapse, increasing the ability of the CS to excite the facilitator neurons. As a result, the CS pathway now, in effect, becomes a potential US pathway, and CS₁ from the siphon might be able to serve as a US for conditioning of responses to stimulation of other sites such as the mantle (CS₂).

Second-order conditioning thus demonstrates that, in addition to changing the ability of a stimulus to produce a motor response, learning also changes the ability of the stimulus to gain access to some of the internal processing machinery over which the US previously had predominant control. This aspect of our neuronal model also suggests a possible reconciliation of two competing theories of learning. On the one hand, Guthrie (1935), Hull (1943), and others have proposed that an association is formed between the conditioned stimulus and the response (S-R) in classical

conditioning. On the other hand, theorists such as Tolman (1932) have proposed that associations are formed between the experimental stimuli (S-S). This S-S viewpoint seems closer to Pavlov's (1927) idea that the conditioned stimulus comes to substitute for the unconditioned stimulus, and thereby produces a response similar to the unconditioned response. Figure 5, Part B, which is a simplified version of Figure 5, Part A, shows that our model incorporates extremely simple neural representations of each of these theories. Thus, changes at the sensory-motor synapses in Figure 5 are obviously consistent with S-R theories, whereas changes at the sensory-interneuron synapses are consistent with S-S theories, because those changes can be thought of as the process by which one stimulus (the CS) comes to substitute for another (the US) in the animal's internal processing machinery. This argument may seem more plausible if the interneuron in Figure 5, Part B is considered as a sensory interneuron, so that the CS comes to produce perceptions in some sense similar to those produced by the US.²

Our simple neuronal model therefore suggests that any instance of learning produces both S-R and S-S types of neuronal changes, with the type expressed perhaps depending on the experimental circumstances. For example, Rescorla and his colleagues have found that habituating the US following second-order conditioning decreases the response to CS₁, but habituating either the US or CS₁ does not decrease the response to CS₂ (Rescorla, 1973). Rescorla has interpreted these results as showing that first-order conditioning is predominantly S-S (that is, CS₁ is associated with the US, which in turn is associated with the response), whereas second-order conditioning is predominately S-R (that is, CS₂ is associated

² The interneuron in Figure 5 can be considered as a sensory interneuron, motor interneuron, or facilitator neuron. In the neuronal circuit for a more complex behavior these functions would presumably be distributed between different interneurons, so that the single interneuron in Figure 5 can be thought of as representing many different interneurons in a more complex circuit. In this case, we are considering it as a sensory interneuron in the US pathway and assuming that firing of that interneuron corresponds to the perception or recollection of some aspect of the US.

directly with the response). The circuit shown in Figure 5 could provide a neuronal explanation for Rescorla's results given two additional assumptions: first, that the interneuron has a discrete threshold for firing, and second, that habituation of the US is accompanied by depression at the interneuron-motor neuron synapse. We also suppose that following second-order conditioning the synaptic strengths of the sensory neurons for CS₁ are greater than those for CS₂, so that CS₁ is strong enough to fire the interneuron but CS₂ is not. CS₁ therefore excites the motor neuron both directly and via the interneuron, whereas CS₂ acts only directly. Under these circumstances habituation of the US decreases the indirect component of the response to CS₁ (due to depression at the interneuron-motor neuron synapse) but does not affect the response to CS₂. Similarly, habituation of CS₁ has no effect on the response to CS₂. This argument is essentially a neuronal version of Rescorla's suggestion that the response to CS₁ has an S-S component, whereas the response to CS₂ is purely S-R.

Blocking

Experimental psychologists have shown that animals learn not only about the temporal pairing or contiguity of stimuli, but also about their correlation or contingency—that is, how well one stimulus predicts another (e.g., Kamin, 1969; Rescorla, 1968). The cellular mechanism we have described for classical conditioning of the *Aplysia* siphon-withdrawal reflex (Hawkins et al., 1983) can account for learning about contiguity, but it cannot directly account for learning about predictability. We suggest that the circuitry shown in Figure 5 might also explain a class of learning phenomena having to do with the predictability of the stimuli, including blocking, overshadowing, and the effect of contingency. We illustrate this point by using blocking as an example. In the first stage of a blocking experiment, CS₁ is conditioned as usual. In the second stage, a second CS (CS₂) is added to CS₁ and the compound stimulus CS₁CS₂ is paired with the US. Generally, there is little conditioning of CS₂, although controls show that good conditioning of CS₂ is obtained if CS₁ is omitted or if CS₁ was not previously conditioned. A cognitive explanation that has

been proposed is that an animal forms expectations about the world, compares current input with those expectations, and learns only when something unpredicted happens (Kamin, 1969). Because CS₁ comes to predict the US in the first stage of training, in the second stage the compound CS₁CS₂ is not followed by anything unexpected and, therefore, little conditioning occurs. Rescorla and Wagner (1972) have formalized this explanation by suggesting that the strength of conditioning is proportional to the difference between the strength of the CS and that of the US. They expressed this relationship in the following equation: $\Delta V_i = K(\lambda - \Sigma V_i)$, where V_i is the associative strength of element i , ΔV_i is the change in that strength on a given trial, K is a constant, and λ is the maximum strength attainable with the US being used. At the beginning of the first stage of training, the strength of CS₁ (V_1) is small, $\lambda - V_1$ is large, and the increment in the strength of CS₁ (ΔV_1) on each trial is large. As training progresses, V_1 becomes larger, ΔV_1 becomes smaller, and V_1 gradually approaches λ . When the second stage of training starts, the strength of CS₂ (V_2) is small, but the sum of V_1 and V_2 (ΣV_i) is nearly equal to λ , so there is little further change in the strengths of either CS₁ or CS₂.

A possible cellular embodiment of this proposal requires an additional assumption, which is that the output of the facilitator neurons decreases when they are stimulated continuously. This mechanism is similar to one that has recently been proposed on theoretical grounds by Wagner (1981), who suggests that activity in the US node in a memory network puts that node in a refractory state for a transient period. (This could occur in *Aplysia* for two reasons: The facilitator neurons undergo accommodation and receive recurrent inhibition, both of which tend to make the facilitators fire only at the onset of a sustained stimulus—Hawkins et al., 1981a and unpublished.) Thus, as the synapses from CS₁ to the facilitator neurons become progressively strengthened during the first stage of training, the facilitator neurons fire more during CS₁ and consequently less during the US (due to the accommodation and recurrent inhibition caused by the firing during CS₁—see Figure 6). This process reaches an asymptote when the firing during CS₁ is strong enough to pre-

vent firing during the US.³ Thus, when training with the compound stimulus CS₁CS₂ starts in the second stage of training, CS₂ is not followed by firing in the facilitator neurons, and therefore CS₂ does not become conditioned. Firing of the facilitator neurons at the onset of CS₂ does not produce amplified facilitation because that process requires a delay between CS onset and the onset of facilitation.

As Rescorla and Wagner (1972) point out, a similar explanation would apply if the same two types of trials (CS₁-US and CS₁CS₂-US) were alternated or intermixed, instead of being presented in two stages of training. According to the model we have described, early in training both CS₁ and CS₂ would gain in associative strength, but CS₁ would gain faster because it is paired with the US more frequently. This process would continue until the combined strength of CS₁ and CS₂ equaled the strength of the US. At that point the compound stim-

ulus CS₁CS₂ would cause enough accommodation and recurrent inhibition in the facilitator neurons to prevent firing during the US, and no further conditioning would occur on the compound (CS₁CS₂-US) trials. In fact, CS₂ would then tend to undergo extinction, and the response to CS₂ would decline to some low level. CS₁ would also undergo extinction on the compound trials, but it would continue to be conditioned on the CS₁-US trials and would gain in strength until its strength equaled that of the US.

These examples illustrate that our model incorporates in very rudimentary forms the notions of predictability and internal representation. The predicted effect of CS₁ is represented internally as the strength of the synapse from CS₁ to the facilitator neuron. The actual consequences of CS₁ are compared to this prediction through the operations of accommodation and recurrent inhibition, which in effect subtract the strength of CS₁ from the strength of the US that follows it. When these

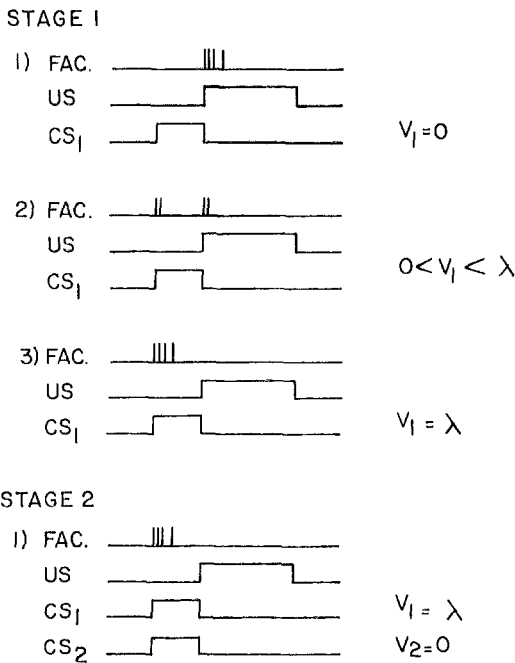

Figure 6. Proposed cellular mechanism of blocking. (As conditioning of CS₁ proceeds [Stage 1, Trials 1, 2, and 3] the facilitator neurons fire more during the conditioned stimulus [CS] period. This firing produces accommodation and recurrent inhibition, which reduce firing during the US period. When compound conditioning starts [Stage 2], CS₂ is not followed by firing of the facilitator neurons and therefore does not become conditioned.)

³ This is a simplification. Like the Rescorla-Wagner model, our model suggests that the strength of conditioning approaches an asymptote because the US becomes progressively less effective. Unlike Rescorla and Wagner, however, we do not predict that the asymptote of conditioning is reached when the strength of the CS equals the strength of the US, but rather at a somewhat lower level. This is because our model includes synaptic depression as well as facilitation. In this respect, it is similar to the model of habituation of Groves and Thompson (1970), who proposed that presentation of any stimulus tends to elicit two competing processes: facilitation of that stimulus pathway via excitation of facilitator neurons, and depression of that stimulus pathway through a homosynaptic mechanism. The net result depends on the balance of the two processes. As Groves and Thompson (1970) point out, this two-process model can explain why repeated presentation of the same stimulus sometimes produces sensitization rather than habituation (see Hawkins et al., 1981b for a similar argument based on the circuit shown in Figure 5, Part A). We have attempted to extend this type of model to classical conditioning. Thus, we propose that on trials early in training, facilitation of the CS pathway caused by firing of the facilitator neurons is greater than depression of the CS pathway caused by firing of the sensory neurons, and therefore the reflex is strengthened. With continued training, the facilitation becomes progressively weaker, and the asymptote of acquisition is reached when the facilitation and depression are equal. During extinction, the facilitator neurons fire even less on each trial than they did at the asymptote of acquisition (because they are excited only by the CS, whereas during acquisition they are excited by both the CS and the US), and therefore depression predominates until a new equilibrium is reached.

two strengths become equal, CS_1 can be said to fully predict the US, which thus loses its reinforcing power, and no further learning occurs. This subtraction process has the additional benefit of setting an upper limit on a positive feedback circuit, thus circumventing a number of theoretical problems that have plagued Hebb-type models.

Degeneration of Learning by Intermittent Presentations of the US Alone or US Preexposure

In classical conditioning, animals do not simply learn that the CS precedes the US (contiguity), but they also learn the contingency or correlation between the CS and US; that is, they learn how well one event predicts another. Thus, if unannounced USs occur between pairing trials, the ability of the CS to predict the US is reduced and learning degenerates. In the limit, if the probability of unannounced USs is the same as the probability of announced (paired) USs so that there is zero contingency, animals do not learn to associate the CS and US despite the fact that they are paired many times (Rescorla, 1968).

Rescorla and Wagner (1972) proposed that this effect could be explained by an extension of the argument they advanced for blocking, simply by including in the analysis the stimuli that are always present in the experimental situation (the background stimuli). Thus, a zero-contingency experiment can be considered as a blocking experiment in which CS background-US trials are intermixed with background-US trials. By the same argument that is outlined above, this would prevent conditioning to the experimental CS. Our cellular version of this argument requires that the conditioned background stimuli be capable of causing continuous excitation of the facilitator neurons, making them unresponsive to the US. Such continuous excitation of the facilitator neurons might be the neural representation of a state of conditioned anxiety.

Our neuronal explanation for blocking involves a rather short-term decrease in the output of the facilitator neurons during and following excitation of those neurons. The idea that the CS and US are interchangeable suggests a second explanation of the effect of contingency, which involves a long-term decrease

in the input to the facilitator neurons. Just as the CS pathway habituates with repeated presentations during extinction, so also might the US pathway undergo habituation with repeated presentations of the US. In a zero-contingency experiment, the unannounced US presentations would cause habituation to the US input, which would make the US less effective on the CS-US trials. If this effect was strong enough, it would more than compensate for the extra sensitization of the CS pathway caused by the unannounced US presentations. Figure 7 illustrates how this might work in an experiment in which animals receive either five trials of normal differential conditioning, or the same five trials plus five unpredicted US presentations. In this hypothetical example

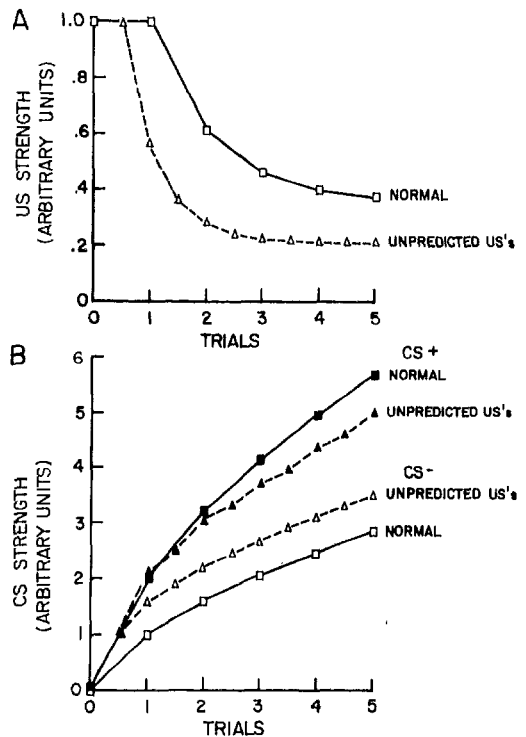

Figure 7. Proposed cellular mechanism of degeneration of learning by intermittent presentation of the unconditioned stimulus (US). *Part A.* US strength on each trial in a hypothetical experiment described in the text. (The US strength is assumed to decrease by 50% with each US presentation and to recover with a time constant of 20 min.) *Part B.* Conditioned stimulus (CS) strength on each trial in the same hypothetical experiment. (The CS is assumed to increase in strength by an amount proportional to the US strength when the US is presented alone, and by twice that amount when the US is paired with the CS.)

the addition of unpredicted USs would not only cause a decrease in the difference between the strengths of the CS^+ and CS^- , but would also cause a decrease in the absolute strength of the CS^+ . Results similar to those shown in Figure 7, Part B, have recently been obtained in *Aplysia* in an experiment with this design (Hawkins, Carew, & Kandel, 1983).

We have suggested two alternate explanations for degeneration of conditioning by presentation of unannounced USs: conditioning of background stimuli (based on our neuronal version of the Rescorla-Wagner model) and habituation of the US input. It may be possible to test these alternatives by performing an experiment in which the additional USs are signaled by a second CS (that is, alternating CS_1 -US and CS_2 -US trials). The Rescorla-Wagner model predicts that conditioning of CS_1 in this case should be nearly the same as that produced by simple CS_1 -US training, whereas the US habituation model predicts that conditioning of CS_1 should be reduced (unless pairing with a CS somehow prevents habituation of the US).

Learning can be impaired by unannounced presentations of the US *before* paired training begins as well as by unannounced USs during training. This treatment, which is called *US preexposure*, is thought to reduce the surprising or novel properties of the US and thus to reduce its effectiveness as a reinforcer. The neuronal mechanism of US preexposure could be the same as either (or both) of the mechanisms proposed above for degeneration of learning by unannounced presentations of the US during training, that is, either conditioning of background stimuli or habituation of the US input. The example of US habituation shown in Figure 7 includes one US preexposure, that contributes significantly to the net effect of the unannounced US presentations in that example.

Conclusion

The approach we have presented here attempts to explain a number of higher order features of learning by combinations of the cellular mechanisms used in simple forms of learning. In particular, we have tried to provide neuronal versions of the Rescorla and Wagner models of conditioning so as to explain some

of the phenomena those models address, including blocking and the effect of contingency. A basic feature of the Rescorla and Wagner models is that learning depends on the degree to which the US is surprising or unpredicted. In our neuronal model we propose that the concepts of predictability and surprise can be related to the more elementary concepts of habituation and sensitization, because the neuronal mechanism for predictability may be the same as that for habituation (synaptic depression or accommodation), and the neuronal mechanism for surprise may be the same as that for sensitization (conventional or activity-dependent presynaptic facilitation). Combinations of these mechanisms might also explain other learning phenomena that we have not discussed here including overshadowing, latent inhibition and the effects of partial reinforcement, intertrial interval, CS strength, and US strength.

The model we describe differs from the Rescorla and Wagner models in an important way: It does not provide for negative learning in a way that is symmetrical with positive learning. Rather, our model depends on synaptic depression for negative learning. Thus, it is basically a two-process model, with the two processes being facilitation and depression. We believe that depression can adequately account for negative learning, although we realize that in many cases the predictions of a competing process model like ours are not obvious and that quantitative simulations are necessary. Our model cannot, however, account for learned inhibition—the actual reversal of sign of the effect of the CS—because the lowest depression can go is zero. Thus our model provides no insight into conditioned inhibition and related learning phenomena. This is not because we have any quarrel with those phenomena, but rather because we have restricted ourselves to the *Aplysia* circuitry shown in Figure 5, which does not include any inhibitory neurons. We do not yet know whether conditioned inhibition occurs in conditioning of the *Aplysia* withdrawal reflex, but if it does occur, we assume it could be modeled by the addition of inhibitory elements to the circuit shown in Figure 5.⁴ Like the Rescorla-Wagner

⁴ Figure 5 shows the minimal neuronal circuit necessary to account for differential conditioning of the gill- and

model, our model also has little to say about many other phenomena in the learning literature such as sensory preconditioning and the exact nature of the conditioned response.

In conclusion, we would emphasize the speculative nature of these proposals. First, although we have used cellular processes and patterns of neuronal connections known to occur in *Aplysia*, not all of the behavioral phenomena we have discussed have yet been demonstrated in *Aplysia*. Conditioning of the gill-and siphon-withdrawal reflex of *Aplysia* shows stimulus specificity, extinction, recovery, and the effect of contingency. Second-order conditioning, blocking, and US preexposure have not been tested in *Aplysia* (although they have been demonstrated in another mollusc, *Limax maximus*). Thus, there is no compelling reason to think that cellular processes that have been observed in *Aplysia* are relevant to all of these behavioral phenomena. Second, we do not provide any data suggesting that higher order features of conditioning must necessarily emerge from the basic cellular mechanisms of more elementary forms of learning. Nor would we argue that participation of the cellular mechanisms that we have outlined here in higher order features of conditioning would provide evidence for their role in yet more sophisticated types of learning. We would only argue that available evidence suggests that classical conditioning and sensitization are not fundamentally different, as is frequently thought, but rather the cellular mechanism of conditioning appears to be an elaboration of the mechanism of sensitization. We have attempted to extend this argument by suggesting that there may be a cellular alphabet of learning and that surprisingly complex forms of learning might be generated from combinations of this alphabet of simple cellular mechanisms. Most important, however, the hypotheses we have described should be testable on the neuronal level in several invertebrates. These tests should in turn indicate the degree to which the notions we have proposed here are useful.

siphon-withdrawal reflex and is not complete. Several known interneurons, including one inhibitory interneuron have been omitted, and many other interneurons have probably not yet been discovered. For a more complete description of the known neuronal circuit, see Hawkins et al. (1981a).

References

- Abrams, T. W., Carew, T. J., Hawkins, R. D., & Kandel, E. R. (1983). Aspects of the cellular mechanism of temporal specificity in conditioning in *Aplysia*: Preliminary evidence for Ca^{2+} influx as a signal of activity. *Society for Neuroscience Abstracts*, 9, 168.
- Alkon, D. L. (1979). Voltage-dependent calcium and potassium ion conductances: A contingency mechanism for an associative learning model. *Science*, 205, 810–816.
- Atkinson, R. C., & Estes, W. K. (1963). Stimulus sampling theory. In R. D. Luce, R. R. Bush, & E. Galanter (Eds.), *Handbook of mathematical psychology* (Vol. 2, pp. 121–268). New York: Wiley.
- Bailey, C. H., & Chen, M. (1983). Morphological basis of long-term habituation and sensitization in *Aplysia*. *Science*, 220, 91–93.
- Bailey, C. H., Hawkins, R. D., & Chen, M. (1983). Uptake of [^3H] serotonin in the abdominal ganglion of *Aplysia californica*: Further studies on the morphological and biochemical basis of presynaptic facilitation. *Brain Research*, 272, 71–81.
- Bernier, L., Castellucci, V. F., Kandel, E. R., & Schwartz, J. H. (1982). Facilitatory transmitter causes a selective and prolonged increase in adenosine 3':5'-monophosphate in sensory neurons mediating the gill and siphon withdrawal reflex in *Aplysia*. *Journal of Neuroscience*, 2, 1682–1691.
- Bush, R. R., & Mosteller, F. (1951). A model for stimulus generalization and discrimination. *Psychological Review*, 58, 413–423.
- Byers, D., Davis, R. L., & Kiger, J. A. (1981). Defect in cyclic AMP phosphodiesterase due to the dunce mutation of learning in *Drosophila melanogaster*. *Nature (London)*, 289, 79–81.
- Carew, T. J., Castellucci, V. F., & Kandel, E. R. (1971). An analysis of dishabituation and sensitization of the gill-withdrawal reflex in *Aplysia*. *International Journal of Neuroscience*, 2, 79–98.
- Carew, T. J., Hawkins, R. D., Abrams, T. W., & Kandel, E. R. (in press). A test of Hebb's postulate at identified synapses which mediate classical conditioning in *Aplysia*. *Journal of Neuroscience*.
- Carew, T. J., Hawkins, R. D., & Kandel, E. R. (1983). Differential classical conditioning of a defensive withdrawal reflex in *Aplysia californica*. *Science*, 219, 397–400.
- Carew, T. J., Pinsker, H. M., & Kandel, E. R. (1972). Long-term habituation of a defensive withdrawal reflex in *Aplysia*. *Science*, 175, 451–454.
- Carew, T. J., Walters, E. T., & Kandel, E. R. (1981). Classical conditioning in a simple withdrawal reflex in *Aplysia californica*. *Journal of Neuroscience*, 1, 1426–1437.
- Castellucci, V. F., & Kandel, E. R. (1974). A quantal analysis of the synaptic depression underlying habituation of the gill-withdrawal reflex in *Aplysia*. *Proceedings of the National Academy of Sciences of the U.S.A.*, 71, 5004–5008.
- Castellucci, V., & Kandel, E. R. (1976). Presynaptic facilitation as a mechanism for behavioral sensitization in *Aplysia*. *Science*, 194, 1176–1178.
- Castellucci, V. F., Nairn, A., Greengard, P., Schwartz, J. H., & Kandel, E. R. (1982). Inhibitor of adenosine 3':5'-monophosphate-dependent protein kinase blocks

- presynaptic facilitation in *Aplysia*. *Journal of Neuroscience*, 2, 1673-1681.
- Castellucci, V., Pinsker, H., Kupfermann, I., & Kandel, E. R. (1970). Neuronal mechanisms of habituation and dishabituation of the gill-withdrawal reflex in *Aplysia*. *Science*, 167, 1745-1748.
- Cegavske, C. F., Patterson, M. M., & Thompson, R. F. (1979). Neuronal unit activity in the abducens nucleus during classical conditioning of the nictitating membrane response in the rabbit (*Oryctolagus cuniculus*). *Journal of Comparative and Physiological Psychology*, 93, 595-609.
- Crow, T.J., & Alkon, D. L. (1980). Associative behavioral modification in *Hermisenda*: Cellular correlates. *Science*, 209, 412-414.
- Dickinson, A., & Mackintosh, N. J. (1978). Classical conditioning in animals. *Annual Review of Psychology*, 29, 587-612.
- Duerr, J. S., & Quinn, W. G. (1982). Three *Drosophila* mutants that block associative learning also affect habituation and sensitization. *Proceedings of the National Academy of Sciences of the U.S.A.*, 79, 3646-3650.
- Gormezano, I. (1972). Investigations of defense and reward conditioning in the rabbit. In A. H. Black & W. F. Prokasy (Eds.), *Classical conditioning II: Current research and theory* (pp. 151-181). New York: Appleton-Century-Crofts.
- Groves, P. M., & Thompson, R. F. (1970). Habituation: A dual-process theory. *Psychological Review*, 77, 419-450.
- Guthrie, E. R. (1935). *The psychology of learning*. New York: Harper.
- Hawkins, R. D. (1981a). Identified facilitating neurons are excited by cutaneous stimuli used in sensitization and classical conditioning of *Aplysia*. *Society for Neuroscience Abstracts*, 7, 354.
- Hawkins, R. D. (1981b). Interneurons involved in mediation and modulation of gill-withdrawal reflex in *Aplysia*. III. Identified facilitating neurons increase Ca^{2+} current in sensory neurons. *Journal of Neurophysiology*, 45, 327-339.
- Hawkins, R. D., Abrams, T. W., Carew, T. J., & Kandel, E. R. (1983). A cellular mechanism of classical conditioning in *Aplysia*: Activity-dependent amplification of presynaptic facilitation. *Science*, 219, 400-405.
- Hawkins, R. D., & Advocat, C. (1977). Effects of behavioral state on the gill-withdrawal reflex in *Aplysia californica*. *Neuroscience Symposia*, 3, 16-32.
- Hawkins, R. D., Carew, T. J., & Kandel, E. R. (1983). Effects of interstimulus interval and contingency on classical conditioning in *Aplysia*. *Society for Neuroscience Abstracts*, 9, 168.
- Hawkins, R. D., Castellucci, V. F., & Kandel, E. R. (1981a). Interneurons involved in mediation and modulation of gill-withdrawal reflex in *Aplysia*. I. Identification and characterization. *Journal of Neurophysiology*, 45, 304-314.
- Hawkins, R. D., Castellucci, V. F., & Kandel, E. R. (1981b). Interneurons involved in mediation and modulation of gill-withdrawal reflex in *Aplysia*. II. Identified neurons produce heterosynaptic facilitation contributing to behavioral sensitization. *Journal of Neurophysiology*, 45, 315-326.
- Hebb, D. O. (1949). *The organization of behavior*. New York: Wiley.
- Hilgard, E. R., & Marquis, D. G. (1940). *Conditioning and learning*. New York: Appleton-Century-Crofts.
- Hoyle, G. (1979). Instrumental conditioning of the leg lift in the locust. *Neuroscience Research Program Bulletin*, 17, 577-586.
- Hull, C. L. (1943). *Principles of behavior*. New York: Appleton-Century-Crofts.
- Kamin, L. J. (1969). Predictability, surprise, attention and conditioning. In B. A. Campbell & R. M. Church (Eds.), *Punishment and aversive behavior* (pp. 279-296). New York: Appleton-Century-Crofts.
- Kandel, E. R. (1978). *A cell-biological approach to learning*. Bethesda, MD: Society for Neuroscience.
- Kandel, E. R., Abrams, T., Bernier, L., Carew, T. J., Hawkins, R. D., & Schwartz, J. A. (1983). Classical conditioning and sensitization share aspects of the same molecular cascade in *Aplysia*. *Cold Spring Harbor Symposia on Quantitative Biology*, 48, 821-830.
- Kandel, E. R., & Schwartz, J. H. (1982). Molecular biology of learning: Modulation of transmitter release. *Science*, 218, 433-443.
- Kistler, H. B. Jr., Hawkins, R. D., Koester, J., Kandel, E. R., & Schwartz, J. H. (1983). Immunocytochemical studies of neurons producing presynaptic facilitation in the abdominal ganglion of *Aplysia californica*. *Society for Neuroscience Abstracts*, 9, 915.
- Klein, M., & Kandel, E. R. (1980). Mechanism of calcium current modulation underlying presynaptic facilitation and behavioral sensitization in *Aplysia*. *Proceedings of the National Academy of Sciences of the U.S.A.*, 77, 6912-6916.
- Klein, M., Shapiro, E., & Kandel, E. R. (1980). Synaptic plasticity and the modulation of the Ca^{++} current. *Journal of Experimental Biology*, 89, 117-157.
- Krasne, F. B. (1969). Excitation and habituation of the crayfish escape reflex: The depolarization response in lateral giant fibers of the isolated abdomen. *Journal of Experimental Biology*, 50, 29-46.
- Mackintosh, N. J. (1974). *The psychology of animal learning*. New York: Academic Press.
- Ocorr, K. A., Walters, E. T., & Byrne, J. H. (1983). Associative conditioning analog in *Aplysia* tail sensory neurons selectively increases cAMP content. *Society for Neuroscience Abstracts*, 9, 169.
- Pavlov, I. P. (1927). *Conditioned reflexes*. (G. V. Anrep, Trans.). London: Oxford University Press.
- Pinsker, H. M., Hening, W. A., Carew, T. J., & Kandel, E. R. (1973). Long-term sensitization of a defensive withdrawal reflex in *Aplysia*. *Science*, 182, 1039-1042.
- Pinsker, H. M., Kupfermann, I., Castellucci, V., & Kandel, E. R. (1970). Habituation and dishabituation of the gill-withdrawal reflex in *Aplysia*. *Science*, 167, 1740-1742.
- Rescorla, R. A. (1968). Probability of shock in the presence and absence of CS in fear conditioning. *Journal of Comparative and Physiological Psychology*, 66, 1-5.
- Rescorla, R. A. (1973). Second-order conditioning: Implications for theories of learning. In F. J. McGuigan & D. B. Hulse (Eds.), *Contemporary approaches to conditioning and learning*. Washington, DC: V. H. Winston.
- Rescorla, R. A. (1978). Some implications of a cognitive perspective on Pavlovian conditioning. In S. H. Hulse, H. Fowler & W. Honig (Eds.), *Cognitive processes in animal behavior* (pp. 15-50). Hillsdale, NJ: Erlbaum.
- Rescorla, R. A., & Wagner, A. R. (1972). A theory of Pavlovian conditioning: Variations in the effectiveness

- of reinforcement and nonreinforcement. In A. H. Black & W. F. Prokasy (Eds.), *Classical conditioning II: Current research and theory* (pp. 64-99). New York: Appleton-Century-Crofts.
- Rosenblatt, F. (1962). *Principles of neurodynamics: Perceptrons and the theory of brain mechanisms*. Washington, DC: Spartan Books.
- Sahley, C., Rudy, J. W., & Gelperin, A. (1981). An analysis of associative learning in a terrestrial mollusc. I. Higher-order conditioning, blocking, and a transient US pre-exposure effect. *Journal of Comparative Physiology*, *144*, 1-8.
- Siegelbaum, S. A., Camardo, J. S., & Kandel, E. R. (1982). Serotonin and cyclic AMP close single K⁺ channels in *Aplysia* sensory neurons. *Nature*, *299*, 413-417.
- Spencer, W. A., Thompson, R. F., & Nielson, D. R., Jr. (1966). Decrement of ventral root electrotonus and intracellularly recorded PSPs produced by iterated cutaneous afferent volleys. *Journal of Neurophysiology*, *29*, 253-273.
- Sutton, R. S., & Barto, A. G. (1981). Toward a modern theory of adaptive networks: Expectation and prediction. *Psychological Review*, *88*, 135-170.
- Thompson, R. F., & Spencer, W. A. (1966). Habituation: A model phenomenon for the study of neuronal substrates of behavior. *Psychological Review*, *173*, 16-43.
- Tolman, E. C. (1932). *Purposive behavior in animals and men*. New York: Century.
- Wagner, A. R. (1978). Expectancies and the priming of STM. In S. H. Hulse, H. Fowler, & W. Honig (Eds.), *Cognitive processes in animal behavior* (pp. 177-209). Hillsdale, NJ: Erlbaum.
- Wagner, A. R. (1981). SOP: A model of automatic memory processing in animal behavior. In N. E. Spear & R. R. Miller (Eds.), *Information processing in animals: Memory mechanisms* (pp. 5-47). Hillsdale, NJ: Erlbaum.
- Walters, E. T., & Byrne, J. H. (1983). Associative conditioning of single neurons suggests a cellular mechanism for learning. *Science*, *219*, 405-408.
- Walters, E. T., Carew, T. J., & Kandel, E. R. (1981). Associative learning in *Aplysia*: Evidence for conditioned fear in an invertebrate. *Science*, *211*, 504-506.
- Zucker, R. S. (1972). Crayfish escape behavior and central synapses. II. Physiological mechanisms underlying behavioral habituation. *Journal of Neurophysiology*, *35*, 621-637.

Received September 19, 1983

Revision received December 7, 1983 ■