

Utah State University

DigitalCommons@USU

All Graduate Theses and Dissertations

Graduate Studies

5-1965

Iterative Method in Storage Routing

Mohan Lal Kapoor
Utah State University

Follow this and additional works at: <https://digitalcommons.usu.edu/etd>



Part of the [Electrical and Computer Engineering Commons](#)

Recommended Citation

Kapoor, Mohan Lal, "Iterative Method in Storage Routing" (1965). *All Graduate Theses and Dissertations*. 1577.

<https://digitalcommons.usu.edu/etd/1577>

This Thesis is brought to you for free and open access by the Graduate Studies at DigitalCommons@USU. It has been accepted for inclusion in All Graduate Theses and Dissertations by an authorized administrator of DigitalCommons@USU. For more information, please contact digitalcommons@usu.edu.



Horizon

UTAH STATE UNIVERSITY



3 9060 01214 4084

ITERATIVE METHOD IN
STORAGE ROUTING

by

Mohan Lal Kapoor

A thesis submitted in partial fulfillment
of the requirements for the degree

of

MASTER OF SCIENCE

in

Electrical Engineering

Approved:

~~Thesis Director~~

~~Major Professor~~

~~Head of Department~~

~~Dean of Graduate Studies~~

Return To:

UTAH WATER RESOURCES LABORATORY
UTAH STATE UNIVERSITY
LOGAN, UTAH 84322

UTAH STATE UNIVERSITY
Logan, Utah

1965

TABLE OF CONTENTS

| | |
|--|----|
| INTRODUCTION | 1 |
| Objectives | 1 |
| Iterative methods | 1 |
| Storage routing | 1 |
| COMPUTING EQUIPMENT | 4 |
| The analog computer | 4 |
| Function generator | 4 |
| Relay and driving unit | 5 |
| X-Y plotter | 5 |
| THE ITERATIVE METHOD | 6 |
| Practical examples | 10 |
| Example 1. Parameter sweep | 10 |
| Example 2. Stepwise operation | 12 |
| STORAGE ROUTING | 17 |
| Single stage storage routing | 17 |
| Problem description | 17 |
| Solution | 17 |
| Specific examples | 20 |
| Routing subsurface flow, 1-hour intervals. | 20 |
| Routing subsurface flow, 12-minute intervals | 23 |
| RESULTS | 33 |
| Practical examples | 33 |
| Storage routing | 33 |
| DISCUSSION | 34 |
| REFERENCES | 36 |

TABLE OF CONTENTS (Continued)

| | |
|--|----|
| APPENDIX | 39 |
| Parameter sweep. | 40 |
| Storage routing | 40 |
| Routing subsurface flow, 1-hour intervals | 41 |
| Routing subsurface flow, 12-minute intervals | 41 |

LIST OF TABLES

| <u>Table</u> | | <u>Page</u> |
|--------------|--|-------------|
| 1 | A comparison of analog and digital computers | 2 |
| 2 | Storage time for different values of resistance and capacitance | 8 |
| 3 | Maximum values of B for different values of k_1 | 13 |
| 4 | Comparison of calculated and observed multistage absorbed concentration | 16 |
| 5 | Comparison of iterative and hand calculated values-- single stage storage routing | 21 |
| 6 | A comparison of methods of routing subsurface flow, one hour intervals | 24 |
| 7 | A comparison of methods for routing subsurface flow, 12-minute intervals | 30 |

LIST OF FIGURES

| <u>Figure</u> | | <u>Page</u> |
|---------------|---|-------------|
| 1 | The circuit used with the function generator | 4 |
| 2 | The circuit of the relay and driving unit | 5 |
| 3 | The integrator circuit | 6 |
| 4 | Output of the integrator circuit | 7 |
| 5 | (a) Output of the first integrator circuit | 9 |
| | (b) Output of the second integrator circuit | 9 |
| 6 | Two amplifiers connected for track and store operation | 9 |
| 7 | The circuit for calculation of the step function . . | 9 |
| 8 | The circuit for solution of simultaneous differential Equations 3 and 4. | 11 |
| 9 | The circuit for finding the maximum values of B versus k_1 in the differential equations | 13 |
| 10 | Speed of chemical reaction--concentration of B versus time | 14 |
| 11 | Speed of chemical reaction--maximum concentration of B versus reaction rate constant | 14 |
| 12 | Multistage gas absorber | 15 |
| 13 | The circuit for computing multistage gas absorber concentration using the iterative method | 15 |
| 14 | Equilibrium concentration of gas versus liquid . . | 16 |
| 15 | The circuit for single stage storage routing . . . | 19 |
| 16 | The inflow hydrograph | 22 |
| 17. | The outflow hydrograph | 22 |

LIST OF FIGURES (Continued)

| <u>Figure</u> | | <u>Page</u> |
|---------------|---|-------------|
| 18 | Increase in the outflow with time | 22 |
| 19 | The circuit for computing storage routing, 1-hour intervals | 25 |
| 20 | The inflow hydrograph | 26 |
| 21 | The relation of storage volume to time, 1-hour intervals | 27 |
| 22 | The relation of discharge to time--outflow computed once per hour | 28 |
| 23 | Inflow hydrograph | 31 |
| 24 | The relation of discharge to time--outflow 12-minute intervals | 32 |
| 25 | (a) Mechanical relay attached to an integrator | 35 |
| | (b) Electronic relay attached to an integrator | 35 |

NOMENCLATURE

| | |
|-------|---|
| E_o | Output voltage |
| E_1 | Input voltage through resistance R_1 |
| E_2 | Input voltage through resistance R_2 and R_3 |
| C_1 | Integrating capacitor |
| k_1 | Reaction rate constant |
| k_2 | Reaction rate constant |
| A | Concentration of a substance |
| B | Concentration of a substance |
| C | Concentration of a substance |
| A_o | Initial value of concentration |
| B_o | Initial value of concentration |
| C_o | Initial value of concentration |
| X_n | Liquid concentration in nth section |
| Y_n | Liquid concentration in nth section |
| I | Inflow rate |
| Q | Outflow rate |
| T_s | Time relation between storage and discharge, direct function of outflow |
| T | Time in hours |

INTRODUCTION

Objective

The objective of this study is to examine the feasibility of applying analog computer iterative methods to the study of storage routing.

Iterative methods

Progress in the field of computer science, as in many other fields has come in steps. One such step in the series is the development of the iterative analog computer. The advantages of the iterative method can be explained by comparing analog and digital computers (Table 1).

The iterative method makes use of the advantages of both types of computers. The method has memory, has the speed of the analog computer, can utilize numerical techniques and requires a minimum of computer equipment.

Storage routing

This paper describes an effort to apply iterative methods to the study of storage routing of water down a river channel.

Analog computers for channel storage routing have been described by the U. S. Weather Bureau (Linsley, Foskett, and Kohler, 1948), the Corps of Engineers (Rockwood and Hidebrand, 1956), and others such as Beyers (1962), Chow (1959), Harder (1959), Kohler (1953), Mitchell (1962), Paynter (1960), Philbrick (1960), Yevdjovich (1960), Nash (1959), and Scheidegger (1960).

Table 1. A comparison of analog and digital computers.

| Digital computer | Analog computer |
|--|--|
| <u>(i) Advantages.</u> | |
| (a) More accuracy, logic and memory. | (a) Higher speed, direct and continuous solution of mathematical functions, simultaneous solution of differential and other equations. |
| (b) Possesses arithmetic device capable of performing long sequence of arithmetic and logical operations. | (b) Easier to program. |
| (c) Automatically chooses the required path for the further course of the calculations subject to the result of intermediate operations. | (c) Simulates complicated functions or problems. |
| <u>(ii) Disadvantages</u> | |
| (a) Complex problems require excessive programming. | (a) The complexity of the problem increases the size of the computer proportionately. |
| (b) Complex by nature, each digit of a word representing an analog quantity must be handled or stored separately. | (b) Accuracy is limited to four digits. |

A promising field of application for electronic computers involves the dynamic routing of water flow in drainage basins from the first raindrops to final torrents. (Philbrick, 1960, p. 239)

There are three types of electrical machines used in flood routing; (a) high-speed, general-purpose electric analog computers that are flexible and speedy (but subject to delays when the programming is altered to conform with changes in flow conditions); (b) differential analysers found suitable especially when the flood routing method is based on the simple storage differential equation (changes of flow conditions can be handled readily and accuracy is very high); and (c) digital computers, where the change of flow conditions can be programmed automatically, and the computational speed is greater than that of an analog, but storage capacity restricts its use. (Yevdjovich, 1960, p. 11)

To save time lost in computing flood stages for endangered downstream points, the U. S. Weather Bureau has invented a machine that eliminates manual computations. The apparatus--named the electronic flood routing machine--automatically produces the hydrograph for the lower end of any selected river while the operator traces with a stylus --on the input unit of the electrical hook-up--the hydrograph of the expected inflow at the upper end of the reach. Thus, the predicted time, peak, duration and slope of the flood hydrograph for the downstream point become known in a few minutes, and specific warning can be broadcast to all threatened communities in time to permit evacuation of people and protection of goods. (Linsley, Foskett, Kohler 1948)

To demonstrate the use of the iterative method three examples will be given. First, a differential equation solution, second, a step function solution and third, the solution of a storage routing problem will be analyzed.

COMPUTING EQUIPMENT

The analog computer

A Donner analog computer was used which has 10 summation or integration amplifiers and 10 coefficient setting potentiometers. Fifer (1961), Jackson (1960), Johnson (1963), Korn and Korn (1964), Warfield (1959), and Wass (1955) may be consulted for details on the use of amplifiers for summation or integration.

Function generator

The required functions were generated by Donner Model 3750. This generator has 24 diodes and can generate any function approximated by 24 straight lines. This circuit is shown in Figure 1.

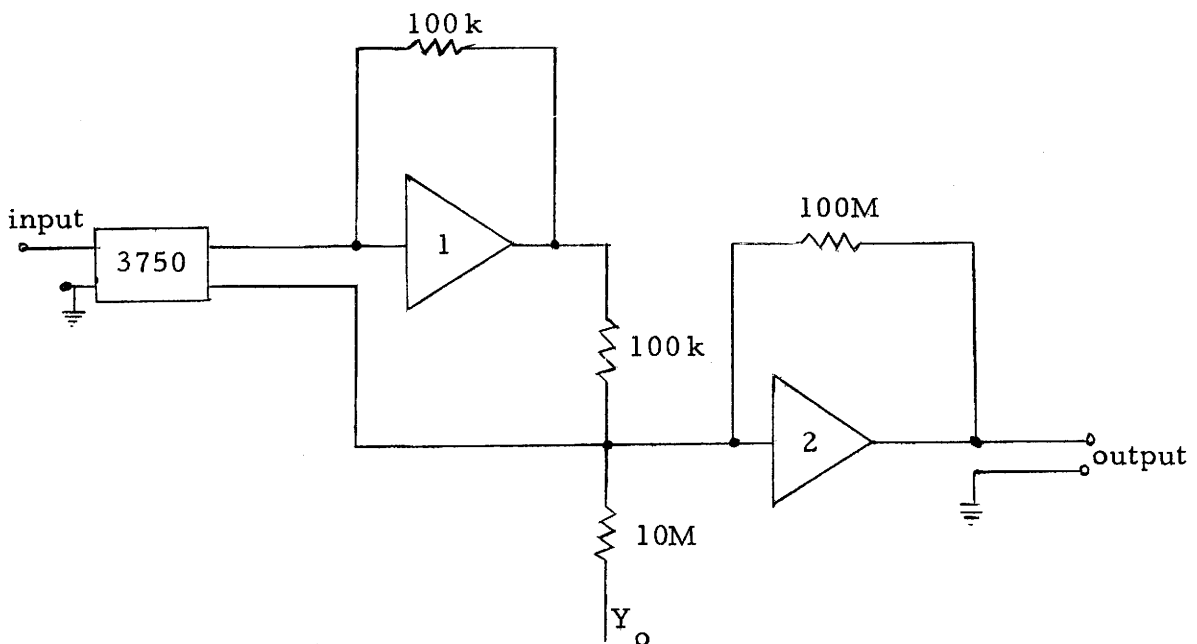

Figure 1. The circuit used with the function generator.

Relay and driving unit

A DPDT mechanical relay, which operates at low frequency, was used for the present study. This relay was driven by the transistor switching circuit shown in Figure 2.

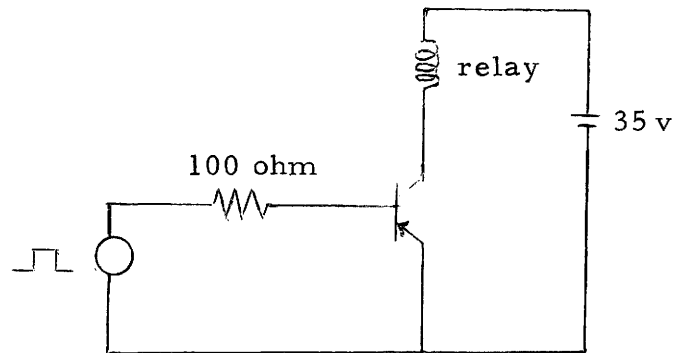

Figure 2. The circuit of the relay and driving unit.

X-Y plotter

The plotter used was an 11-inch by 17-inch Electronic Associates Incorporated, Model 1100. This plotter produces both X and Y deflections proportional to their dc input voltages.

THE ITERATIVE METHOD

The iterative method is repetitive which enables memorization of computed information during one part of the computation and its use in the second part. The iterative method enables us to solve stepwise calculations, partial differential equations, and many complicated storage problems. The simple integrator is modified to use as a track and store mechanism. The integrator is shown in Figure 3.

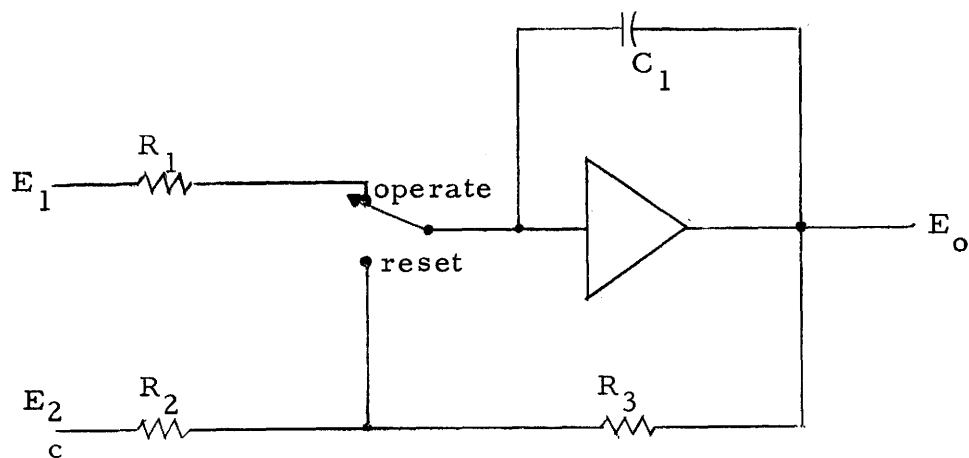

Figure 3. The integrator circuit.

In Figure 3 E_1 is the normal input to the integrator, R_1 is the input resistance, E_o is the output voltage, C_1 is an integrating capacitor, and E_2 is the initial-condition-voltage which is to be stored on the capacitor C_1 , through the resistances R_2 and R_3 . The normal input channel is not used but the integrator input is applied through the point c.

The circuit in Figure 3 is used for tracking and storing information. When the circuit is used to track, the switch is set to "reset mode" as

in Figure 3 and the input signal fed into point c. In the reset mode, the capacitor is charged with the voltage negative with respect to the voltage to be stored. In "set operate," with no input voltage, the output voltage remains at the last value it had before the mode position was changed.

During the reset mode, the capacitor C_1 is charged to the voltage, E_2 , while the relay is in reset mode position. The important point is that the mode relay should remain in "reset" position for sufficient time to allow C_1 to completely charge to the voltage E_2 . When the mode relay is in the "operate mode"

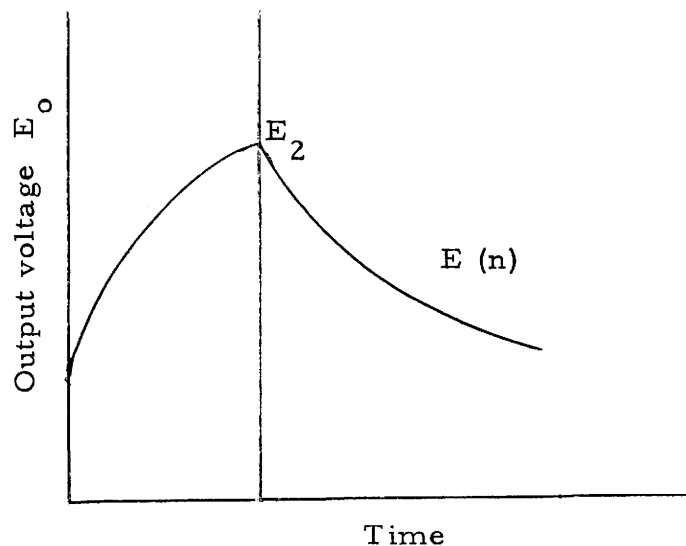

Figure 4. Output of the integrator circuit.

The time required for complete charge of capacitor C_1 is assumed to be $5 RC$. The times for the capacitor to charge to its initial value E_2 for different resistances and capacitances are given

in Table 2.

Table 2. Storage time for different values of resistance and capacitance.

| Resistance (R2) | Capacitance (C ₁) | RC (time constant) | 5RC |
|-----------------|-------------------------------|--------------------|------------|
| 1.0 megohm | 1.0 ufd. | 1.0 sec. | 5.0 sec. |
| 0.1 megohm | 1.0 ufd. | 0.1 sec. | 0.5 sec. |
| 0.1 megohm | 0.1 ufd. | 0.01 sec. | 0.05 sec. |
| 0.1 megohm | 0.01 ufd. | 0.001 sec. | 0.005 sec. |

Table 2 shows that for high speed a low value of resistance and capacitance should be used.

The output of the amplifier is connected to the point d (Figure 6) of a second similar amplifier shown in Figure 3. The combined circuit of these two amplifiers is shown in Figure 6. The second amplifier is connected in the "operate mode." Since the second amplifier has no input except through the point d it will track the output of the first amplifier until the relay operates. Outputs from each amplifier are shown in Figure 5. In Figure 5b, the output up to point b is called "track." Point b is known as "learn" and the straight line, bc, is called "store." The important feature of this technique is the output from one operation can be utilized in the second. The circuit for such an operation is shown in Figure 7. To clarify this operation, a step equation may be considered:

$$Y_{n+1} = A X_n + B \dots \dots \dots 1$$

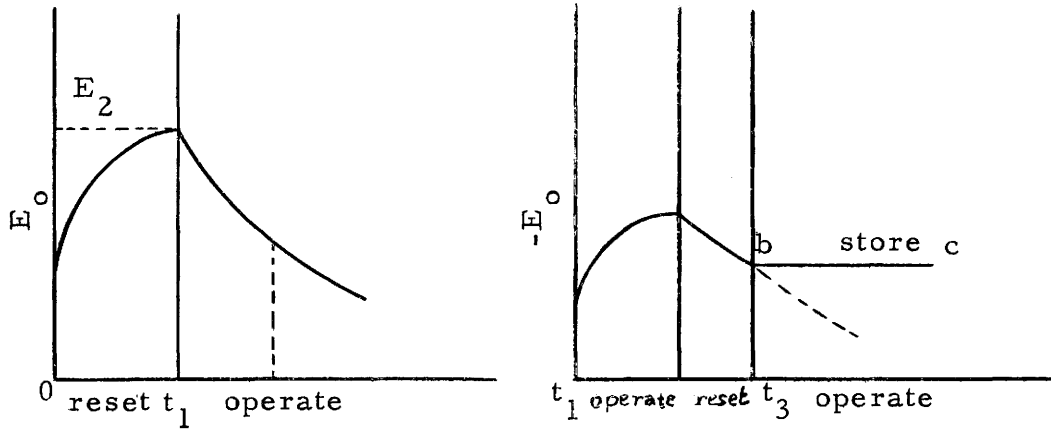

Figure 5. (a) Output of the first integrator circuit.
 (b) Output of the second integrator circuit.

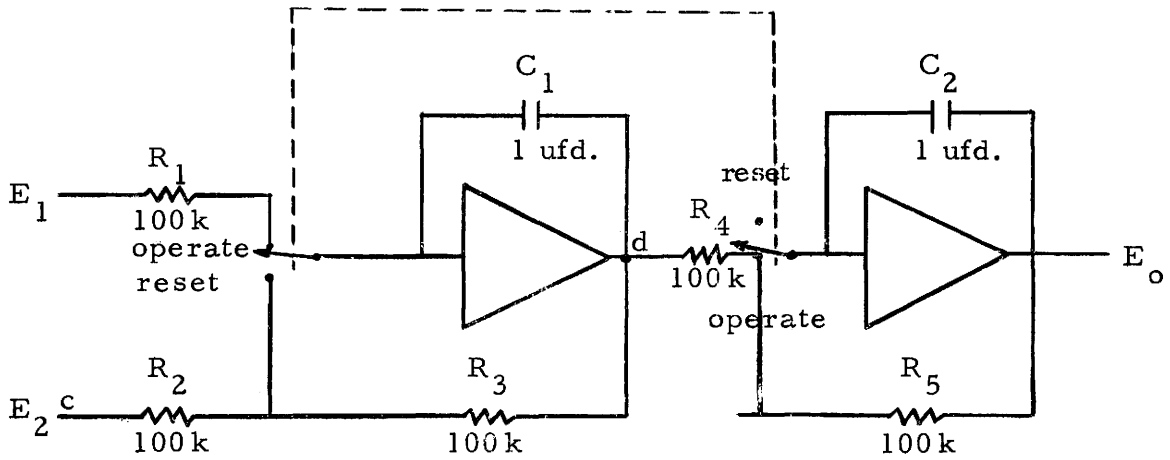

Figure 6. Two amplifiers connected for track and store operation.

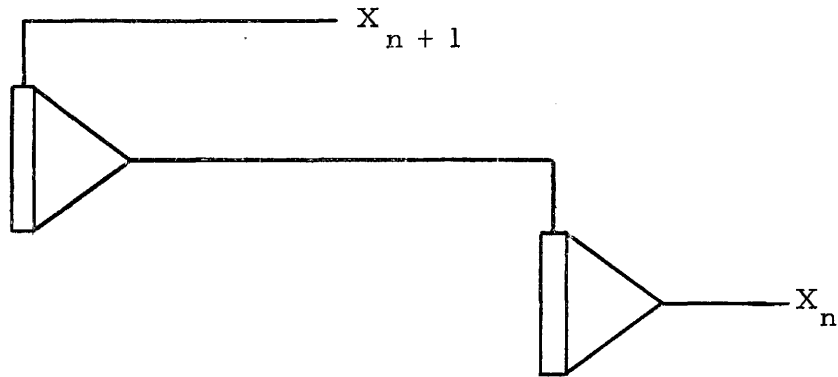

Figure 7. The circuit for calculation of the step function.

The equations for three different values of k_1 namely 0.4, 0.5, and 0.6 were solved. The results obtained are shown in Figure 10.

In order to find the maximum value of B in Equations 3 and 4, for values of k_1 varying between 0 and 1, another circuit (Figure 9) was used. This circuit has a track and store mechanism and can record the maximum values of B for different values of k_1 continuously. The circuit has track and store capability and can compute the maximum values of B versus k_1 as k_1 varies from 0 to 1.

The curve obtained from this circuit is shown in Figure 11. For verification, the differential equations were solved mathematically and shown on page 40 of the Appendix. The maximum values of B for k_1 equal to 0.4, 0.5, and 0.6, as well as the maximum values obtained by the above two methods, are given in Table 3.

Example 2. Stepwise operation. A multistage gas absorber is shown in Figure 12. The absorber is divided into n sections and the gas concentration Y versus liquid concentration X for each stage is to be determined.

The equilibrium equation for each stage is given by:

$$X_n = Y_n \times 1.2 \dots \dots \dots 5$$

A material balance gives:

$$Y_{n+1} = 0.9 X_n + 0.60 \dots \dots \dots 6$$

The circuit to solve Equations 5 and 6 is given in Figure 13. The curve obtained from this circuit is shown in Figure 14. Equations 5

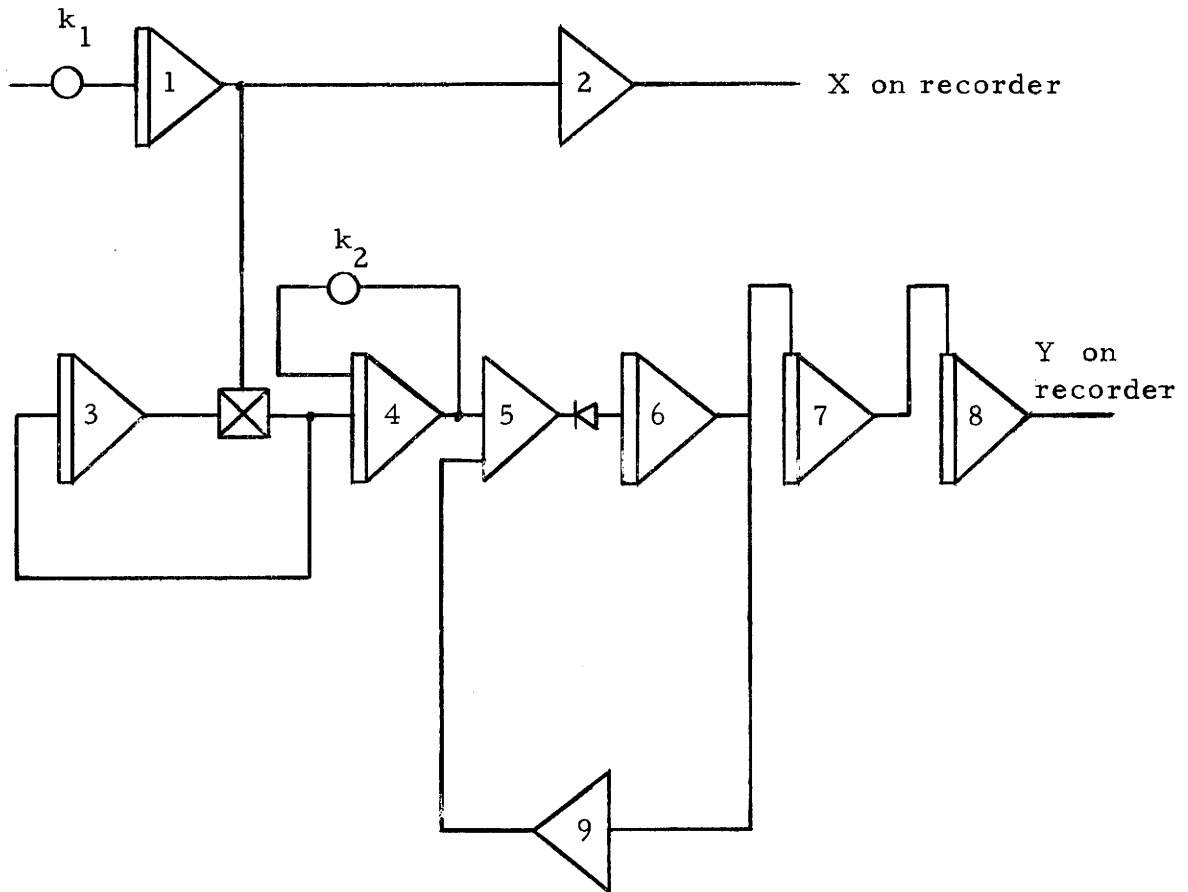

Figure 9. The circuit for finding the maximum values of B versus k_1 in the differential equations.

Table 3. Maximum values of B for different values of k_1

| Analog method | Iterative method | Calculated |
|---------------|------------------|------------|
| 22 | 22 | 22.0 |
| 25 | 25 | 24.5 |
| 29 | 28 | 28.5 |

and 6 were also solved mathematically. The calculated values as well as the observation obtained from the iterative method are shown in Table 4.

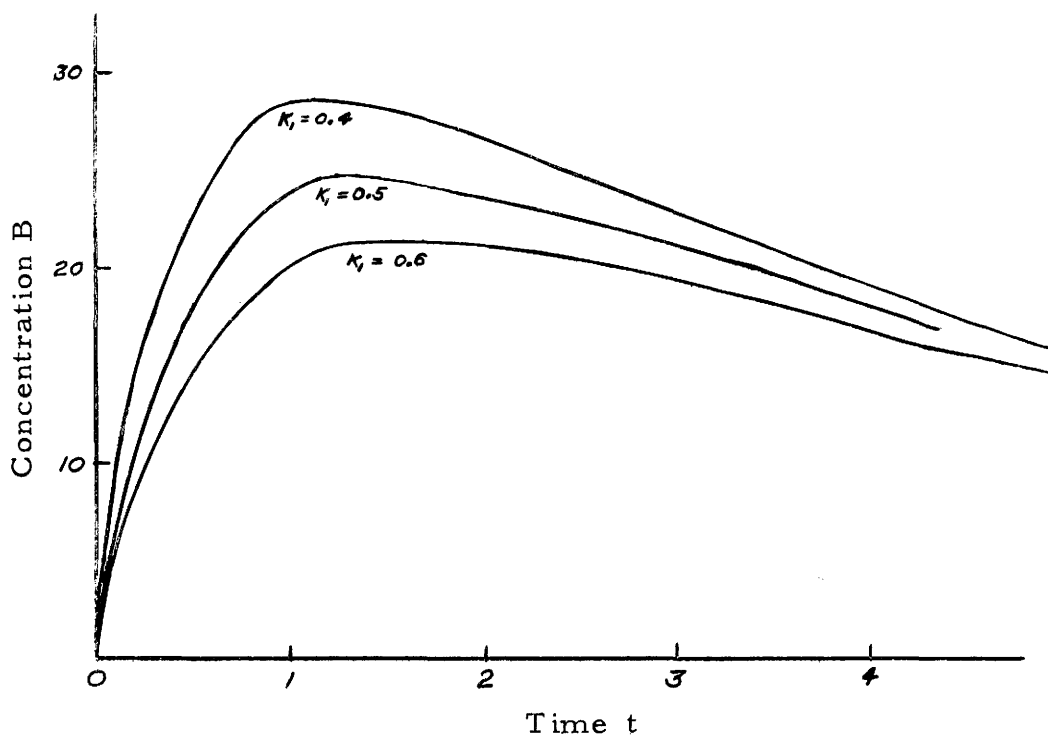

Figure 10. Speed of chemical reaction--concentration of B versus time.

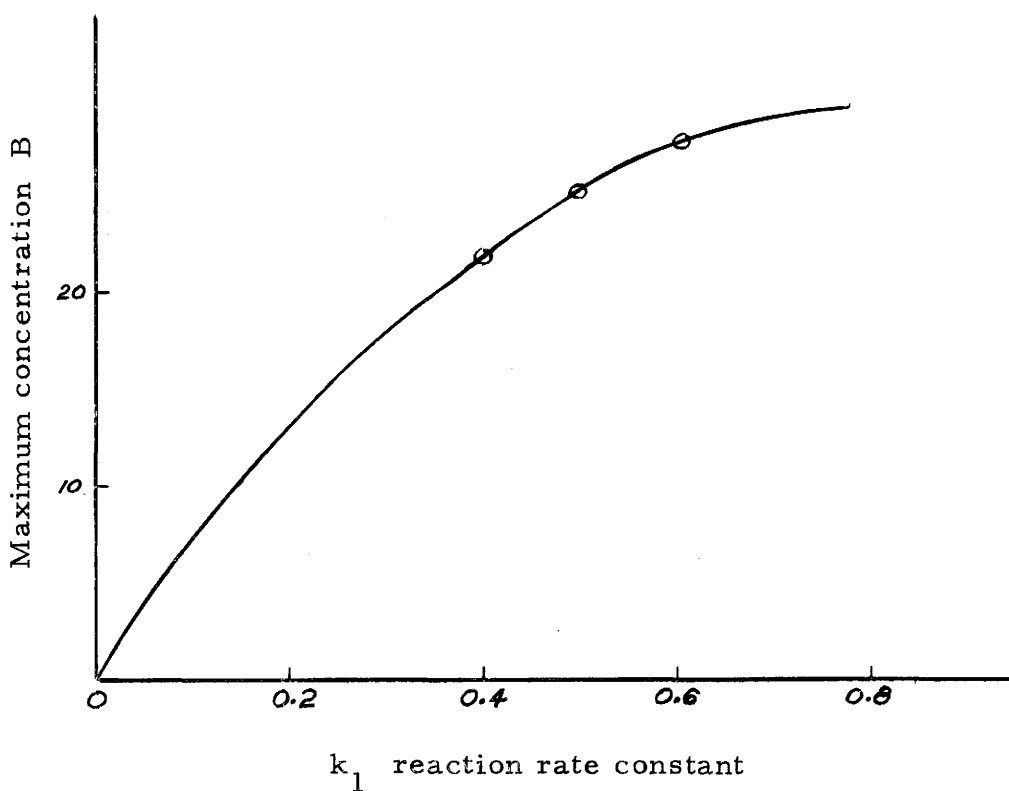

Figure 11. Speed of chemical reaction--maximum concentration of B versus reaction rate constant.

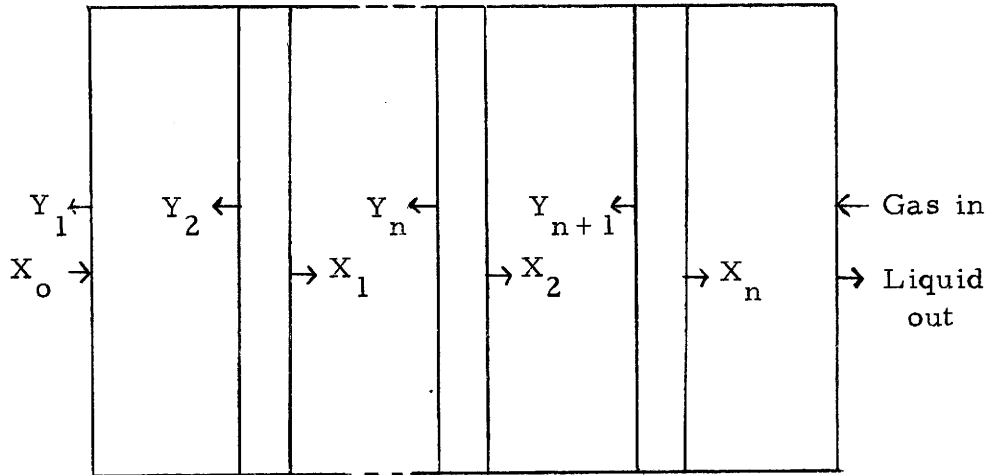

Figure 12. Multistage gas absorber.

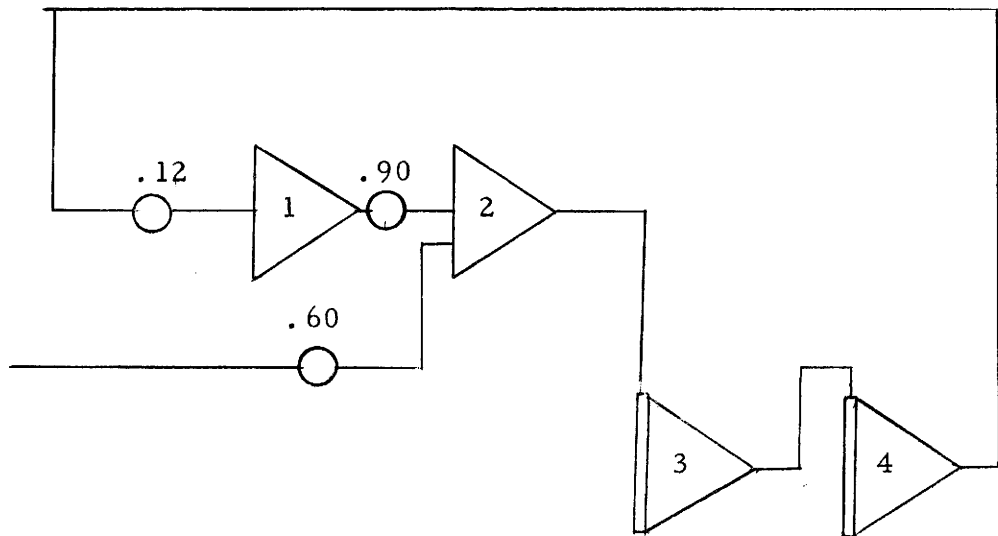

Figure 13. The circuit for computing multistage gas absorber concentration using the iterative method.

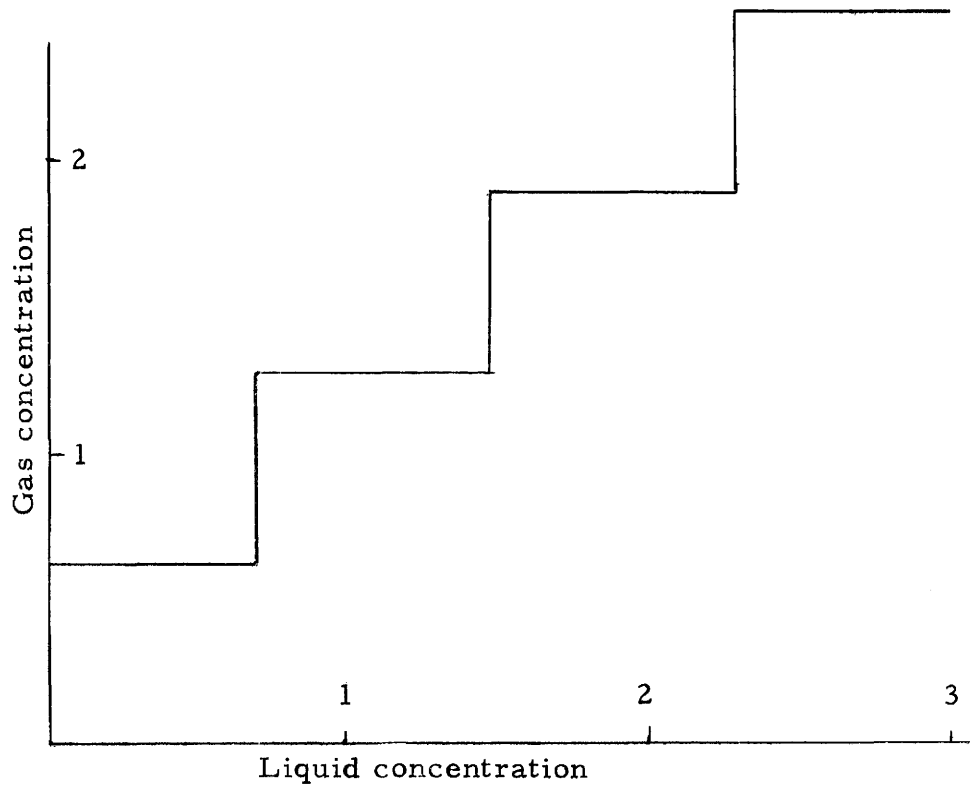

Figure 14. Equilibrium concentration of gas versus liquid.

Table 4. Comparison of calculated and observed multistage absorber concentration.

| X observed iteration method | X calculated | Y observed iteration method | Y calculated |
|-----------------------------------|-----------------|-----------------------------------|-----------------|
| 0.00 | 0.00 | 0.60 | 0.60 |
| 0.72 | 0.72 | 1.24 | 1.25 |
| 1.49 | 1.48 | 1.95 | 1.90 |
| 2.30 | 2.28 | 2.65 | 2.67 |

STORAGE ROUTING

Single stage storage routing

Problem description. In storage routing, the inflow can be considered as the general hydrograph. Since the inflow traverses channels, it involves the hydraulics of flow in open channels.

A hydrograph is defined as a curve obtained by plotting the discharge against time. The hydrograph is a practical method of integrating the effects of size, drainage density, shape, stream pattern, channel capacities, stream gradients and land slopes. In the unit hydrograph, it is assumed that if the distribution of the rainfall over the entire area is uniform and of the same duration, the hydrograph will be similar. For further details, Chow (1959), Nash (1959), Shen (1963), and Singh (1962) may be consulted.

Solution. The problem of storage routing has been computed for a period of 8 hours with one hour iterations. Each hour represents a stage. For calculating the storage of one stage, the outflow of one stage is subtracted from the inflow to the next stage or hour. The change in outflow from a stage is computed by multiplying its storage by a constant. Hence, the outflow becomes the outflow of one stage plus the change in that outflow. The circuit used for the computation of this outflow problem is shown in Figure 15. This circuit provides the desired time-varying input voltage, which represents the inflow.

The function generator was set up to produce the required input voltage as follows:

A curve of inflow versus time was drawn on a sheet of graph paper. This graph was then placed on the table of the X - Y plotter. Small voltage steps were fed into the X channel. For each voltage, corresponding value of magnitude Y and slope were established by adjusting the break-point and slope controls. At steeper slopes, the number of break-points was increased to improve the fitting precision. Details of these adjustments may be found in the instruction manual.

The inflow generated by the function generator is applied to Amplifier 4, where the outflow is subtracted from the inflow to obtain net storage. The increase in the outflow is determined by multiplying the storage by a constant which in the present case, is 0.5. (See Appendix page 40.) This increase in outflow is added to the outflow of the previous stage to find the value of the total outflow. In Figure 15, the outflow is subtracted from the inflow to Amplifier 4, the increase in the resultant outflow is determined by multiplying by the constant, 0.5, with the potentiometer. This quantity is added to the outflow in summation Amplifier 5. The total outflow is delayed with the help of the iterative method shown in Amplifiers 6 and 7. The outflow from Amplifiers 6 and 7 is subtracted from the inflow to Amplifiers 8 and 4. This process is repeated and the inflow, storage, increase in outflow, and outflow is recorded on the X - Y plotter. The plotter traces

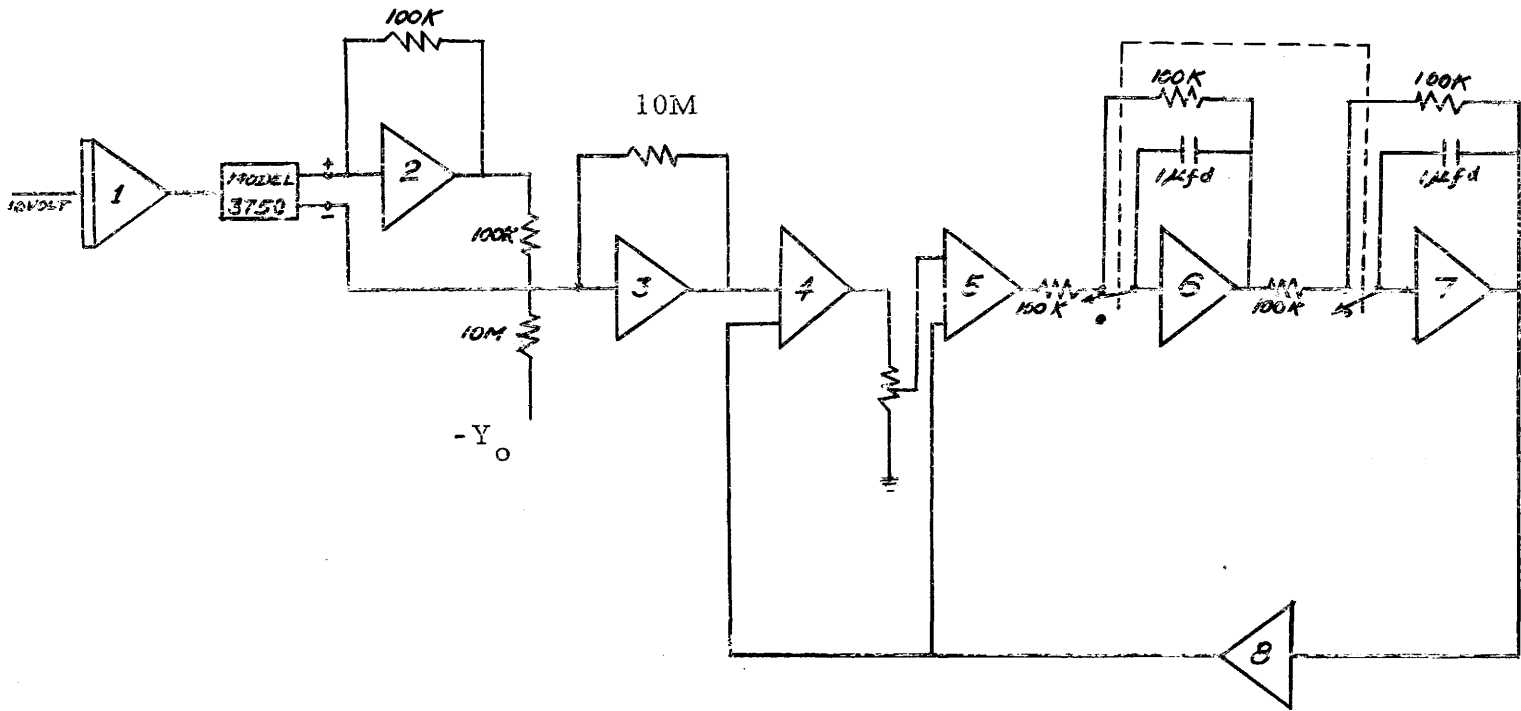

Figure 15. The circuit for single stage storage routing.

obtained are shown in Figures 16, 17, and 18. The values of different flows are taken from these curves and are shown in Table 5. Inflow, storage, increase in outflow, and outflow have also been calculated and are also shown in Table 5.

Specific examples

Routing subsurface flow, 1-hour intervals. The inflow hydrograph was obtained from the hydrographs prepared by the U. S. Geological Survey and the Forest Service (Water Supply Paper 884) for San Dimas Basin for the Flood of 2 March, 1938. For this case, the value of T_s (storage discharge relationship) was determined as 1.5 to 3 hours. For my computation, this value was assumed to be 2.7 hours. The value of T_s was chosen from U. S. Geological Survey Water Supply Paper 884, pages 162, 167, from which the following quotations are taken:

In Fern Canyon Watershed No. 2, the lag in time of occurrence between the rainfall and the associated runoff appears to be generally from 1 1/2 to 3 hours, which seems to be rather excessive for a drainage area of only 0.063 square miles with a maximum travel of about 0.4 miles. This apparently excessive lag tends to support the conclusion that much of the runoff moved through subterranean channels, with the result that the flow was slower than the flow in surface channels and may have been subjected to the influence of groundwater storage.

For a total rainfall of 20.44 inches during the storm, the 1/40 acre plots at Fern Canyon showed a direct surface runoff of only 0.17, 0.08, and 0.06 inches. With an average rate of rainfall of 1.52 inches for a 15 minute period, the direct surface

Table 5. Comparison of iterative and hand calculated values--single stage storage routing.

| | | Calculated | | | Obtained from Figures 16, 17, 18 | | | | |
|------|--------|------------|---------|---------------|----------------------------------|---------|---------|-------|--|
| Time | Inflow | Storage | Outflow | Total outflow | Inflow | Storage | Outflow | Total | |
| 1 | 2 | 3 | 4 | 5 | 6 | 7 | 8 | 9 | |
| 1 | 2 | 2.0 | 1.0 | 1.0 | 2.0 | 2.0 | 1.0 | 1.0 | |
| 2 | 4 | 3.0 | 1.5 | 2.5 | 4.0 | 3.0 | 1.6 | 2.6 | |
| 3 | 10 | 7.5 | 3.7 | 6.2 | 10.0 | 7.5 | 3.7 | 6.2 | |
| 4 | 14 | 7.8 | 4.0 | 10.2 | 14.0 | 7.8 | 4.5 | 10.3 | |
| 5 | 18 | 7.8 | 4.0 | 14.2 | 18.0 | 7.8 | 4.0 | 14.6 | |
| 6 | 13 | -1.2 | -0.6 | 13.6 | 13.0 | -1.2 | -1.0 | 14.0 | |
| 7 | 5 | -8.6 | -4.5 | 9.1 | 5.0 | -8.6 | -4.8 | 9.5 | |
| 8 | 0 | -9.1 | -4.5 | 4.6 | 0 | -9.1 | -4.8 | 4.6 | |

1. Time in hours.
2. Inflow in 1000 cubic feet.
3. Storage in 1000 cubic feet (calculated).
4. Outflow in 1000 cubic feet (calculated).
5. Total outflow, i.e. the outflow from one stage added to the total outflow of the previous stage (calculated).
6. Inflow.
7. Storage by the iterative method.
8. Outflow by the iterative method.
9. Total outflow, i.e. the outflow from one stage added to the total outflow of the previous stage by the iterative method.

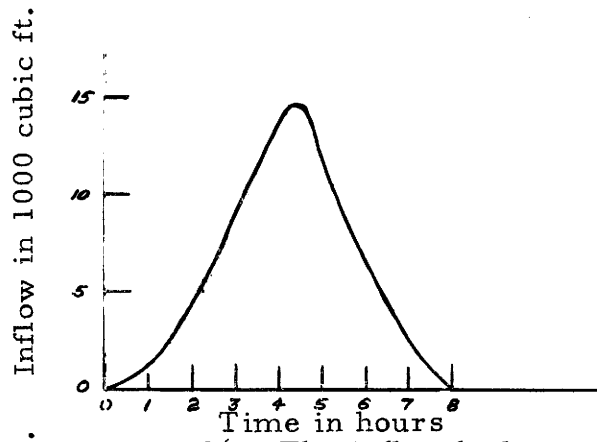

Figure 16. The inflow hydrograph.

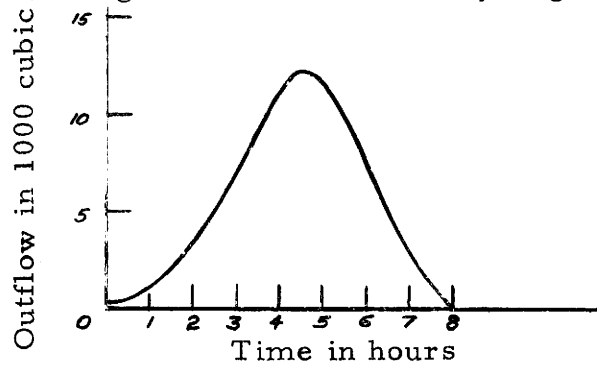

Figure 17. The outflow hydrograph.

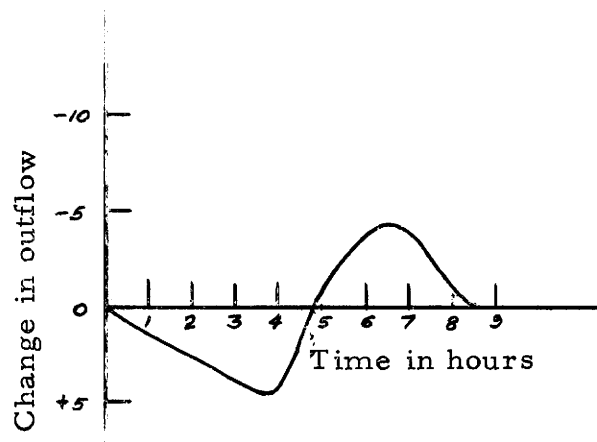

Figure 18. Increase in the outflow with time.

runoff amounted to less than 0.02 inches per hour It appears that a considerable part of the precipitation that was absorbed by the soil mantle, as shown by the plot experiments, and thence into the streams and that its movement was rather rapid.

The storage routing circuit is shown in Figure 19. Operation of this circuit is explained in the section on storage routing. For the storage routing problem, the storage constant was 0.3 instead of 0.5. Computation of the storage constant is given on page 41 of the Appendix.

The storage Table 6, column 3, is obtained by subtracting the outflow from the inflow. The change in outflow is determined by multiplying this constant by 0.3, as shown in column 4. The total outflow is determined by adding the change-in-outflow to the outflow from the previous stage. Column 6 shows, the mean value of the outflow in one hour.

The circuit used for this purpose is shown in Figure 19. The relay was operated at 2 cycles per second.

The results obtained by the iterative method along with the results obtained by other workers are shown in Table 6 and Figure 22.

Routing subsurface flow, 12-minute intervals. For greater detail, observations were recorded at 12-minute intervals instead of 1-hour intervals. In this case, the storage constant was 0.078 to correspond with the reduced time interval. The circuit used is shown in Figure 19. The circuit and other considerations are the same as those outlined for 1-hour duration except that the capacitor was 0.1 ufd.

Table 6. A comparison of methods of routing subsurface flow, 1-hour intervals.

| Time (hrs) | Inflow | Storage (I-Q)x 0.3 | | Outflow | | Recorded | Trial | Iterative method | |
|------------|--------|--------------------|-----|---------|------|----------|-------|------------------|---------|
| | | 3 | 4 | 5 | 6 | | No. 2 | Storage | Outflow |
| 1 | 2 | 3 | 4 | 5 | 6 | 7 | 8 | 9 | 10 |
| 10 | 1400 | 810 | 240 | 830 | 1050 | 1220 | 1000 | 800 | 1100 |
| 11 | 2300 | 1470 | 440 | 1270 | 1480 | 1700 | 1300 | 1470 | 1650 |
| 12 | 2650 | 1380 | 420 | 1690 | 1730 | 1730 | 1650 | 1360 | 1800 |
| 13 | 2100 | 410 | 120 | 1810 | 2250 | 2090 | 2050 | 500 | 2100 |
| 14 | 4750 | 2940 | 880 | 2690 | 3070 | 3200 | 2900 | 2850 | 3200 |
| 15 | 5250 | 2560 | 760 | 3450 | 3880 | 4100 | 3600 | 2500 | 3900 |
| 16 | 6300 | 2850 | 850 | 4300 | 4285 | 4010 | 4100 | 2750 | 4260 |
| 17 | 4200 | -100 | -30 | 4270 | 4260 | 4200 | 4150 | -90 | 4250 |

1. Time in hours.
2. Inflow to storage
3. Storage calculated by hand.
4. (I-Q) x 0.3 calculated value of the increase in the outflow.
5. Calculated outflow.
6. Calculated (mid value) outflow.
7. Recorded observations 1938.
8. Observations computed by Trial No. 2 in the report 'Storage routing analog for subsurface flow' by L. A. Beyers, Physicist, University of Idaho, and J. M. Rosa, Hydraulic Engineer (mid value).
9. Storage by iterative method.
10. Outflow (mid value) by the iterative method.

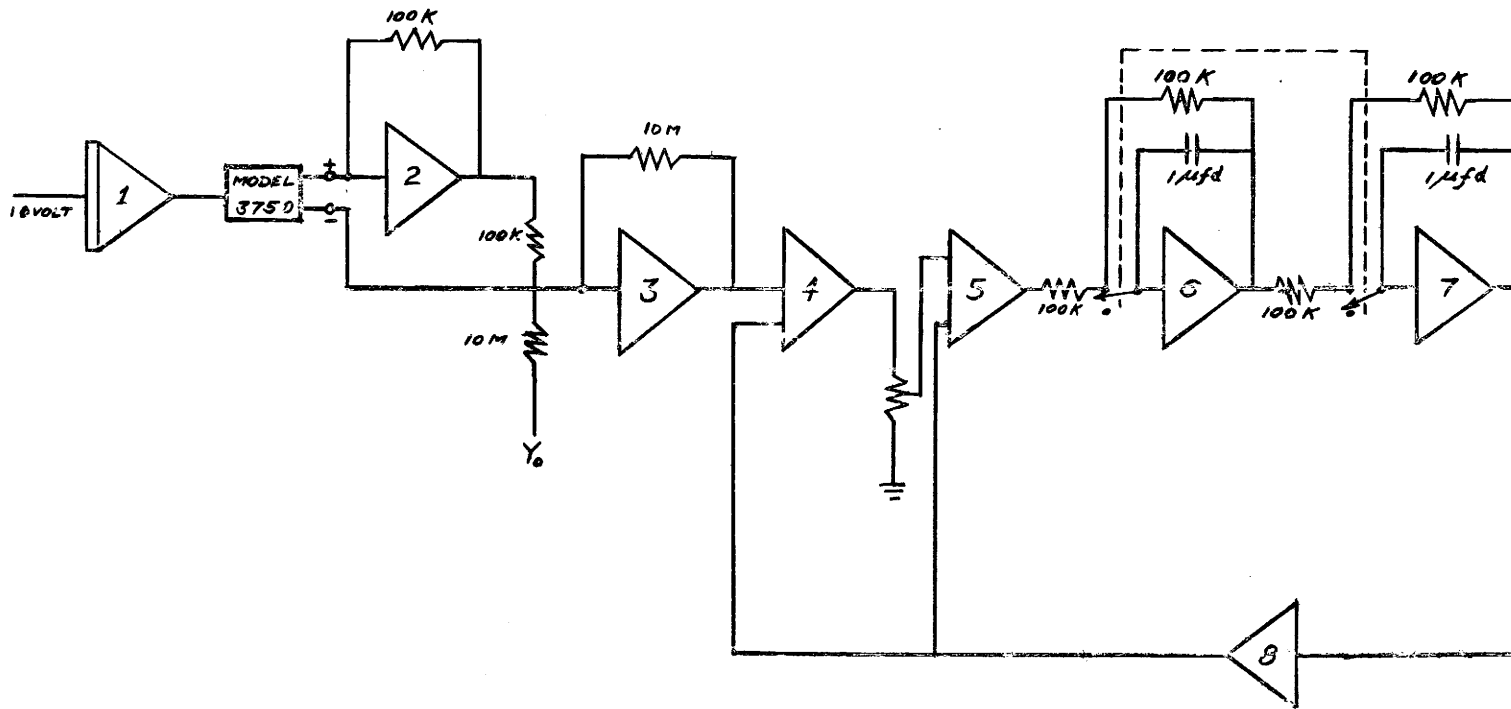

Figure 19. The circuit for computing storage routing, 1-hour intervals.

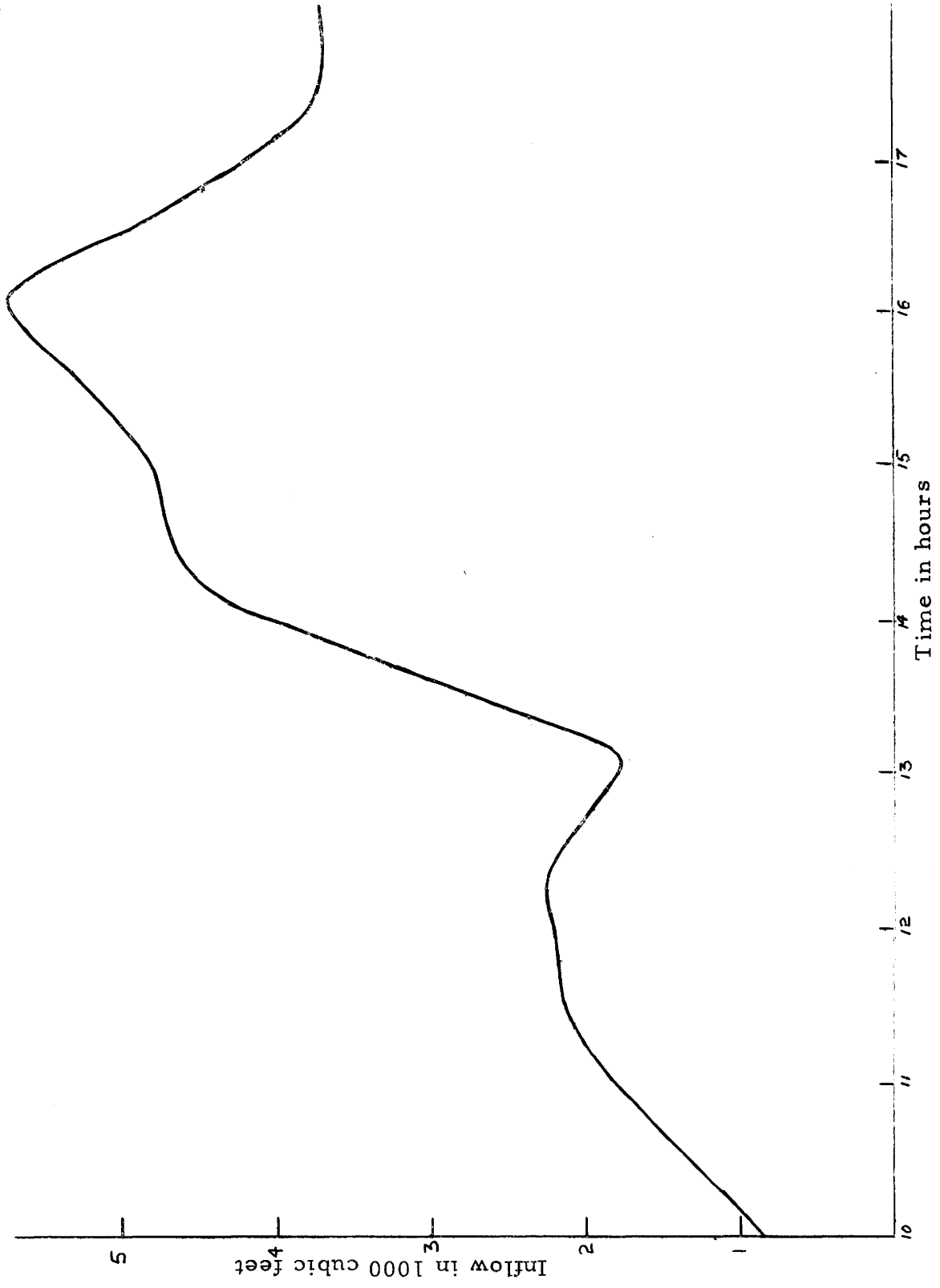

Figure 20. The inflow hydrograph.

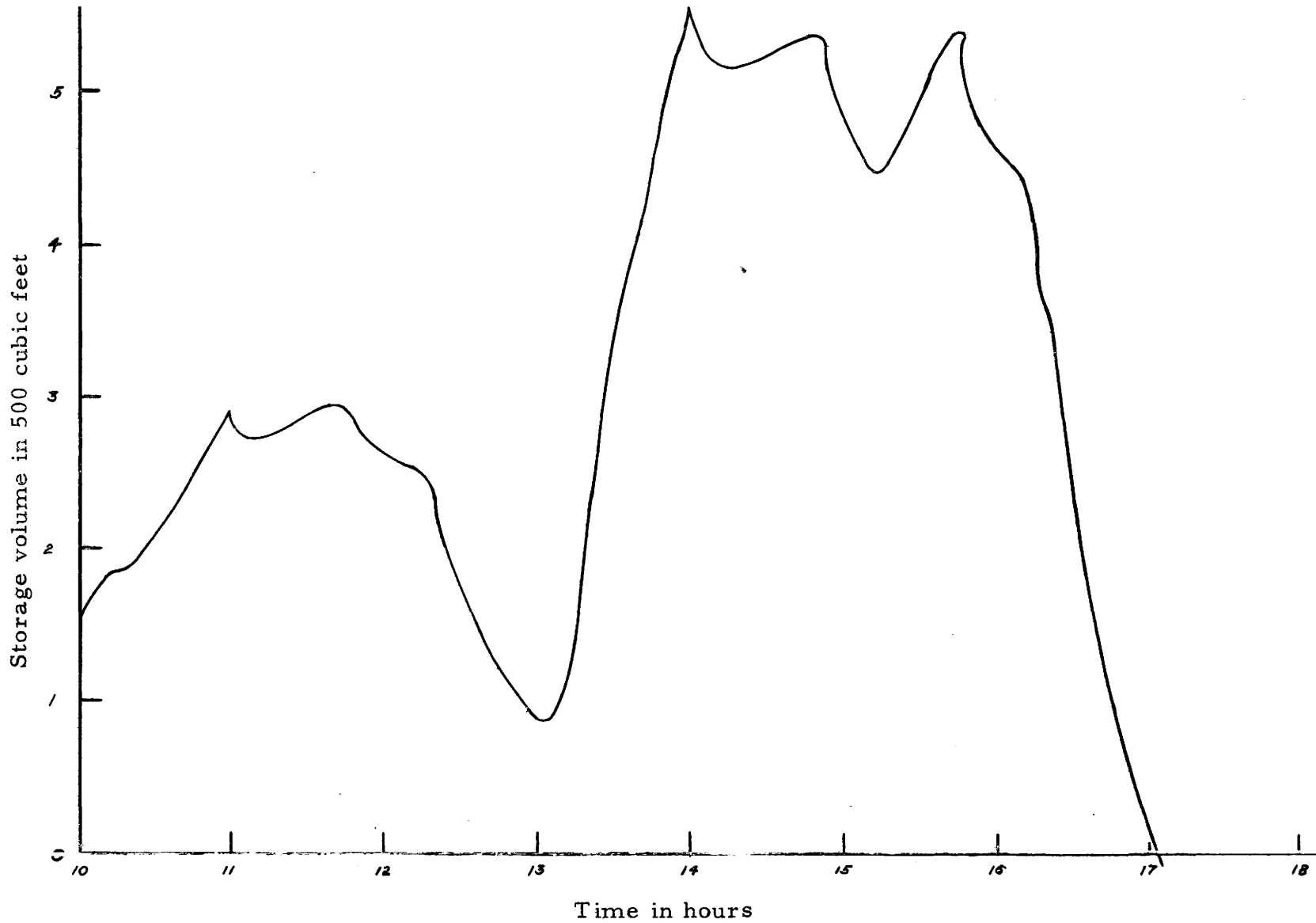

Figure 21. The relation of storage volume to time, 1-hour intervals.

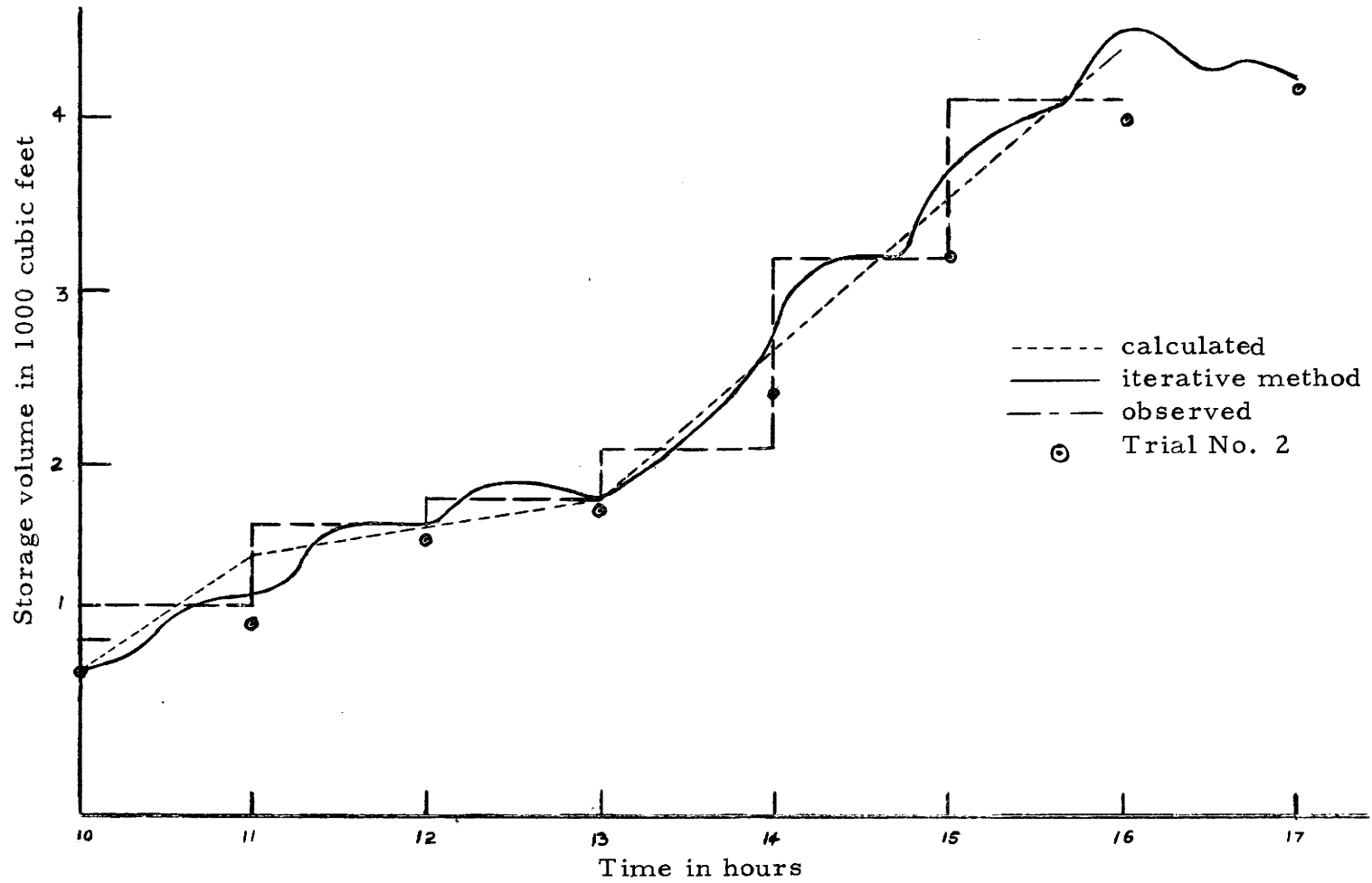

Figure 22. The relation of discharge to time--outflow computed once per hour.

instead of 1 ufd. The storage constant is shown on page 41 of the Appendix.

Hand calculated values as well as those obtained by the other methods are shown in Table 7.

Table 7. A comparison of methods for routing subsurface flow, 12-minute intervals.

| Time (hrs) 1 | Inflow 2 | Storage 3 | Outflow 4 | Trial No. 2 5 | Iterative method | |
|-----------------|-------------|--------------|--------------|---------------------|------------------|--------------|
| | | | | | Storage 6 | Outflow 7 |
| 10 | 1400 | 810 | 830 | 830 | 810 | 830 |
| 11 | 2300 | 1470 | 1270 | 1120 | 1450 | 1270 |
| 12 | 2650 | 1380 | 1690 | 1525 | 1360 | 1750 |
| 13 | 2100 | 410 | 1810 | 1724 | 550 | 1810 |
| 14 | 4750 | 2940 | 2690 | 2325 | 2800 | 2690 |
| 15 | 5250 | 2560 | 3450 | 3000 | 2550 | 3600 |
| 16 | 5300 | 2850 | 4300 | 3800 | 2780 | 4350 |
| 17 | 4200 | -100 | 4270 | 3950 | -20 | 4200 |

1. Time in hours.
2. Inflow to storage.
3. Storage hand computed.
4. Outflow hand computed.
5. Observation computed by Trial No. 2 in the report 'Storage routing analog for subsurface flow' by L. A. Beyers, Physicist, University of Idaho, and J. M. Rosa, Hydraulic Engineer.
6. Storage by iterative method.
7. Outflow by the iterative method.

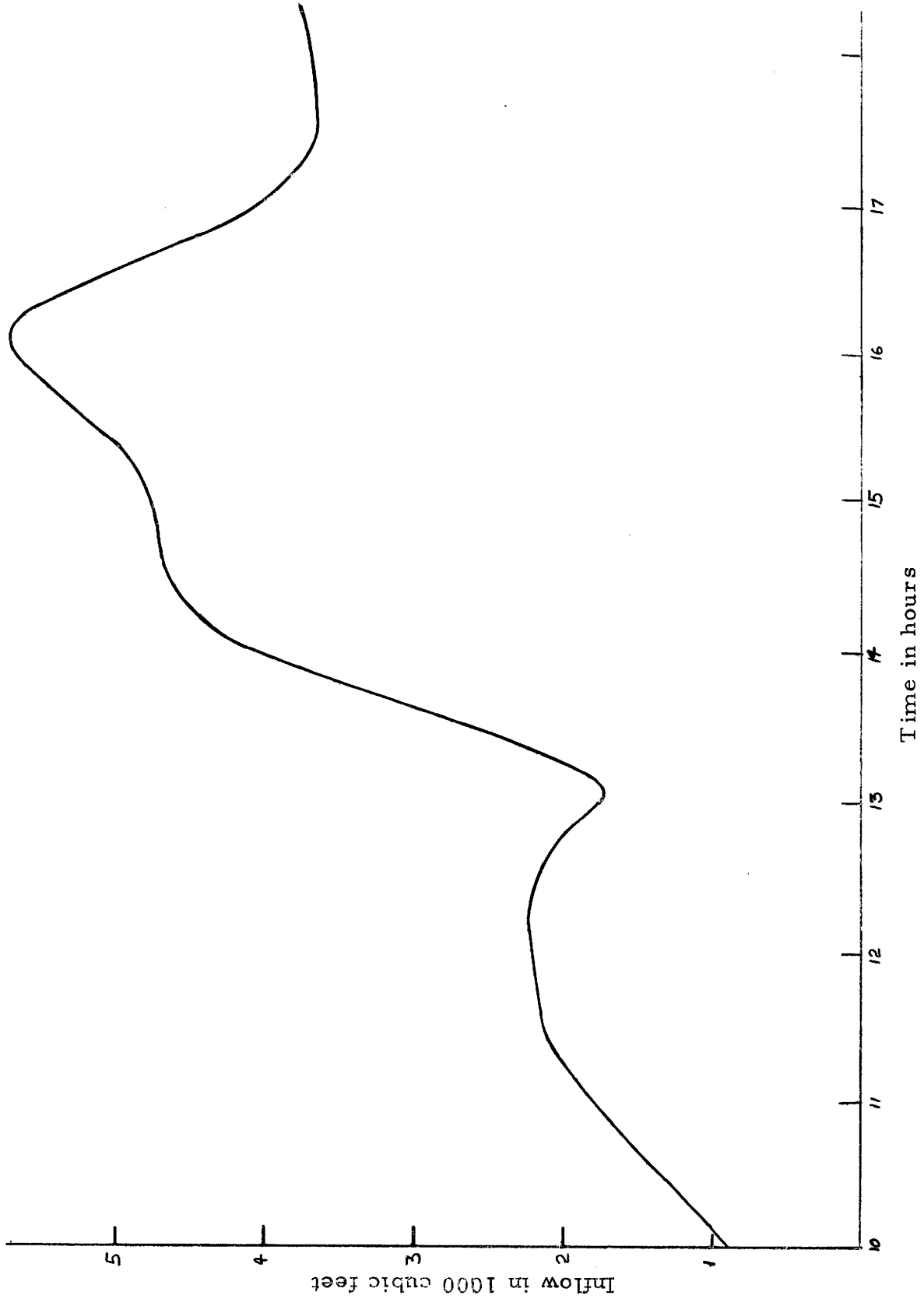

Figure 23. Inflow hydrograph.

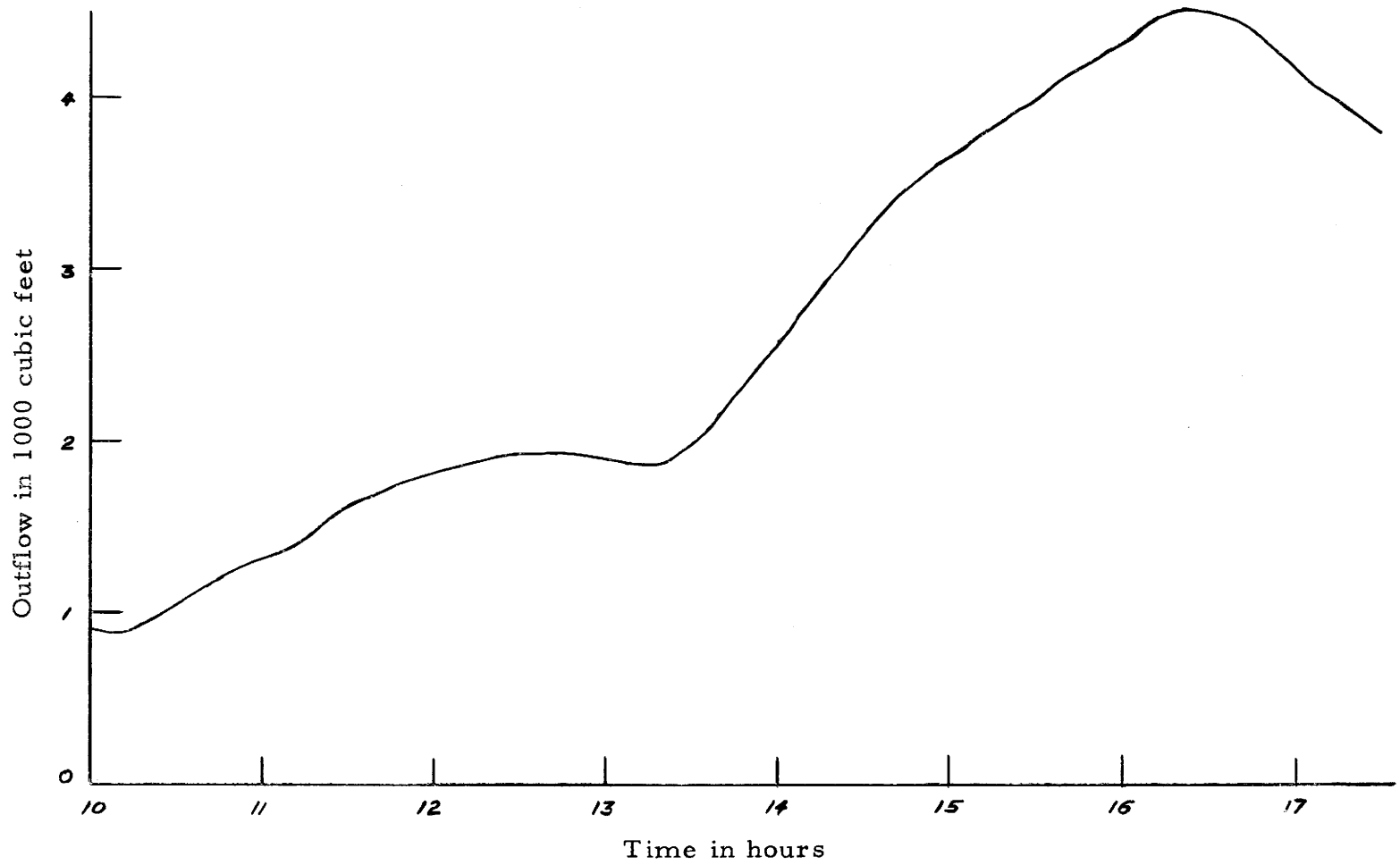

Figure 24. The relation of discharge to time--outflow 12-minute intervals.

RESULTS

Practical examples

Two practical examples considered were; first, determination of the effect of the reaction-rate constant, k_1 , on the maximum concentration reached by the substance B, in a reaction; and second, calculation of the gas and liquid concentrations in a counter-current multistage gas absorber. These examples were used to verify the use of the iterative method on the analog computer. The results in Tables 3 and 4 confirm that this method is satisfactory for problems involving storage.

Storage routing

After obtaining values for storage from one inflow hydrograph, storage, as well as outflow, can be determined for unknown flows. One example from an actual flood in Southern California is shown in Figure 22. In the California flood the iterative method appears to be more accurate than other methods. It is evident from Tables 6 and 7 that iterative techniques compare well with hand calculated and those actually recorded.

DISCUSSION

The present experiment has demonstrated a technique for solving storage problems. The iterative analog computer widens the scope of problems solved on an ordinary analog computer.

Further study of the iterative method should be made as follows:

- (1) Use of an electronic switch instead of the mechanical switch used in the present study, to speed up the computer. An ordinary mechanical relay with a RC delay charges the capacitor to its full value, and limits the high speed capability. In the case of an electronic switch, as shown in Figure 25, the computer can be operated at higher speeds. In this case, isolating Amplifier 1 reduces the impedance of the source. The resistance across the capacitor is approximately 50 ohms, including electronic switch.
- (2) Use of a comparator in a problem, such as melting of snow (where the snow melts at a particular temperature) should be tested. With a comparator, the computer will compute only at temperatures above the melting point. The use of diodes with an amplifier as a comparator should be tested. For further information consult Johnson (1963).
- (3) The Donner computer is equipped with ten amplifiers. The REAC computer, with a larger number of amplifiers, could be used by bringing the grid connections to the patch panel. The Donner and REAC computers can be used together by making interconnections.

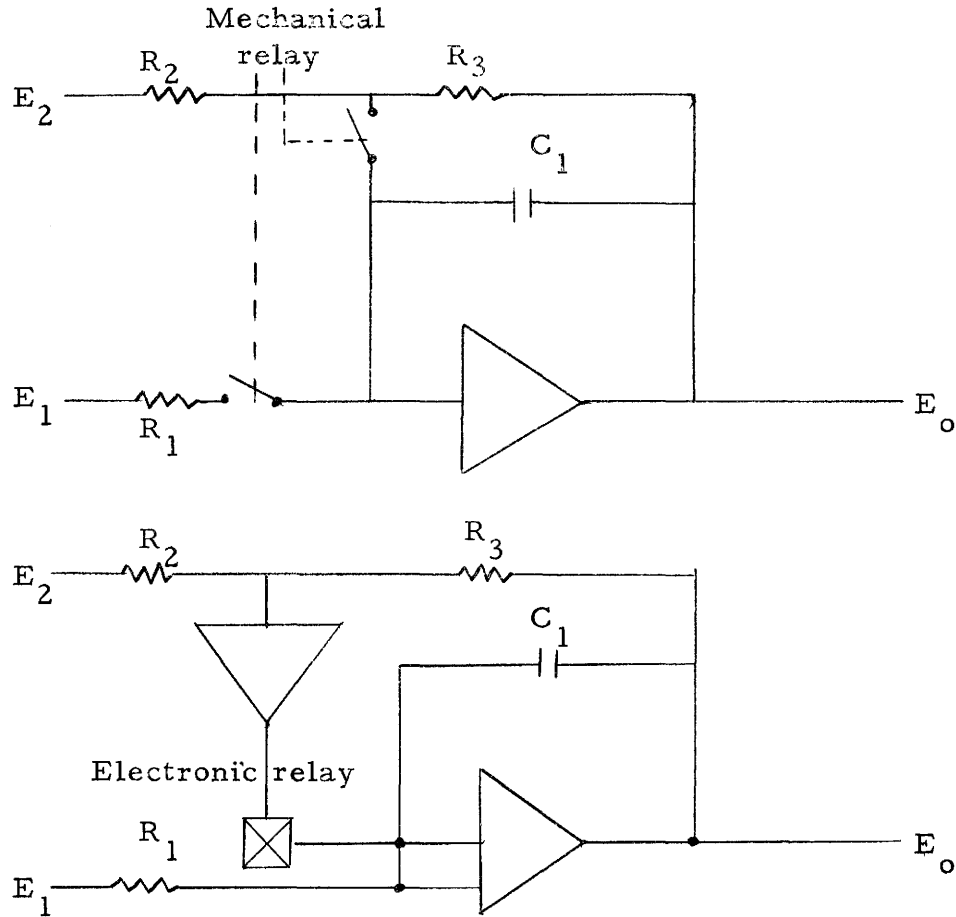

Figure 25 (a) Mechanical relay attached to an integrator.

25 (b) Electronic relay attached to an integrator.

(4) In the present study the time intervals have been 12 minutes and 1 hour. Other time intervals should be studied.

(5) More than one store-and-track unit should be used for more storage.

REFERENCES

- Beyers, L. A. 1962. Development of the electronic analog to snow melting on a watershed. Northeast Branch, Soil and Water Conservation Research Division, Agricultural Research Service, U. S. Department of Agriculture.
- Beyers, L. A., and H. M. Rosa. 1961. Storage routing analog for subsurface flow. Soil and Water Conservation Division, Agricultural Research Service, U. S. Department of Agriculture.
- Chow, Ven Te. 1959. Open channel hydraulics. McGraw-Hill Book Co., Inc., New York, N. Y.
- Donnell, O. T. 1965. A symposium on river flood hydrology. Institute of Civil Engineers.
- Fifer. 1961. Analog computation. McGraw-Hill Book Co., Inc., New York, N. Y.
- Grabbe, E. M. 1959. Handbook of automation computation and control. Vol. 2. John Wiley and Sons, New York, N. Y.
- Harder, J. A. 1960. Flood control analogs. Water Resources Center, Contribution No. 24, University of California, Berkeley, p. 1.
- Jackson, A. S. 1960. Analog computation. McGraw-Hill Book Co., Inc., New York, N. Y.
- Johnson, C. L. 1963. Analog computer techniques. 2nd ed. McGraw-Hill Book Co., Inc., New York, N. Y.
- Kohler, M. A. 1953. Application of electronic flow routing. Transactions, American Society of Civil Engineers, 18:1028-1043.
- Korn, G. A., and T. M. Korn. 1964. Electronic analog and hybrid computer. McGraw-Hill Book Co., Inc., New York, N. Y.
- Linsley, R. K., L. W. Roskett, and M. A. Kohler. 1948. Electronic device speeds flood forecasting. Engineering News Record, U. S. Weather Bureau, Washington, D. C.
- Mitchell, W. D. 1962. Effect of reservoir storage on peak flow. U. S. Geological Survey Water Supply, 1580-C.

REFERENCES (Continued)

- Nash, J. E. 1959. Form of the instantaneous unit hydrograph. Proceedings, International Association of Scientific Hydrology, 3:114-121.
- Osburn, J. O. 1964. Track and store with your computer. Instruments and control systems. November. 37(11):145-146.
- Paynter, H. M. 1960. Computer techniques in hydrology in palimpsest on electronic analog art. Printed by G. A. Philbrick Researchers, Inc., Boston, Massachusetts.
- Philbrick, G. A. 1960. Computer techniques in hydrology, from a palimpsest on the electronic analog art. Researchers, Inc., 285 Columbus Avenue, Boston 16, Massachusetts.
- Rockwood, D. M., and C. E. Hiderand. 1956. An electronic analog for multistage reservoir type routing. Technical Bulletin 18, Corps of Engineers, Civil Works Investigations, Project CW-171.
- Scheidegger, A. E. 1960. The physics of flow through porous media. MacMillan Co., New York, N. Y.
- Scott, H. R. 1960. Analog and digital computer technique. McGraw-Hill Book Co., Inc., New York, N. Y.
- Shen, John. 1963. Use of hydrologic models in the analysis of flood runoff. U. S. Geological Survey Preliminary Report.
- Singh, K. P. 1962. A nonlinear approach to the instantaneous unit hydrograph theory. Ph.D. Thesis, University of Illinois, Urbana.
- Smith, G. W., and R. C. Wood. 1959. Principles of analog computation. McGraw-Hill Book Co., Inc., New York, N. Y.
- Tomovic, R., and W. S. Karpuls. 1962. High speed analog computers. McGraw-Hill Book Co., Inc., New York, N. Y.
- Warfield, J. N. 1959. Introduction to electronic analog computers. Prentice-Hall, Inc., New York, N. Y.
- Wass, C. A. 1955. Introduction to electronic analog computers. McGraw-Hill Book Co., Inc., New York, N. Y.

REFERENCES (Continued)

- Yevdjovich, V. M. 1960. Flood routing methods, Discussion and bibliography, Geological Survey for Engineering Division, Soil Conservation Service, U. S. Department of Agriculture, Project No. 4, Washington, D. C.

APPENDIX

Parameter sweep

The rate of change of concentration of 'A' and 'B' are given by the equations:

$$\begin{aligned} dA/dt &= -k_1 A \\ dB/dt &= k_1 A - k_2 B \\ B &= 100 k_1 / (k_1 - k_2) (e^{-k_2 t} - e^{-k_1 t}) \\ k_1/k_2 &= e^{(k_1 - k_2)t} \end{aligned}$$

Storage routing

$$\begin{aligned} I &= \Delta Q + dS/dT \\ &= \Delta Q + T_s dQ/dT \end{aligned}$$

in which

$$\begin{aligned} I &= \text{Inflow rate} \\ Q &= \text{Outflow rate} \\ T_s &= \text{Time relation between storage and discharge,} \\ &\text{direct function of outflow. Time of storage can} \\ &\text{vary with flow, actually varies in natural} \\ &\text{channels.} \end{aligned}$$

$$\begin{aligned} I - Q &= \Delta Q (1/2 + S/T Q) \dots \dots \dots (A) \\ &= \Delta Q (1/2 + T_s/T) \end{aligned}$$

for the present problem, it is assumed that

$$T_s = 3/2$$

therefore

$$I - Q = Q(1/2 + 3/2)$$

$$\Delta Q = 0.5 \times (I - Q)$$

Routing subsurface flow, 1-hour intervals

In this problem

$$T = 1 \text{ hour}$$

$$T_s = 2.8 \text{ hours}$$

From Equation (A)

$$\begin{aligned} I - Q &= Q(1/2 + T_s/T) \\ &= Q(1/2 + 2.8/1) \end{aligned}$$

$$\Delta Q = 0.3 \times (I - Q)$$

Routing subsurface flow, 12-minute intervals

In this problem

$$T = 12 \text{ minutes} = 1/5 \text{ hours}$$

$$T_s = 2.8 \text{ hours}$$

Equation (A) is

$$\begin{aligned} I - Q &= \Delta Q(1/2 + T_s/T) \\ &= \Delta Q(1/2 + 2.8 \times 5) \end{aligned}$$

$$\Delta Q = 0.078$$