

WCPCG-2010

# Job satisfaction and organizational commitment as antecedents of Organizational Citizenship Behavior (OCB) of teachers

Hassanreza Zeinabadi<sup>a</sup> \*

<sup>a</sup> Tarbiat Moallem University of Tehran, Faculty of Education and Psychology, Department of Educational Administration, 15614, Iran

Received January 9, 2010; revised February 16, 2010; accepted March 11, 2010

---

## Abstract

Little empirical research has looked at casual relationships between job satisfaction, organizational commitment and OCBs of teachers. Also there is minimal attention to the impact of specific facet of job satisfaction and organizational commitment on OCB of teachers. The purpose of this study was to investigate casual relationships through testing 36 structural models. The sample was 652 teachers and 131 principals. Data were collected through 3 questionnaires. Results showed that just 1 model has the best fit indexes. In this model, intrinsic job satisfaction is a dominant variable which influence OCB directly and indirectly through partial mediating role of value commitment.

© 2010 Elsevier Ltd. All rights reserved.

*Keywords:* Job satisfaction, organizational commitment, OCB, teacher.

---

## 1. Introduction

Success of schools fundamentally depends on teachers who are willing to go beyond role expectations voluntary (DiPaola & Tschannen-Moran, 2001). Organizational citizenship behavior (OCB) is a useful term to describe these voluntary behaviors and has originally coined by Organ (1988). Derived from Katz's (1964) idea of extra-role behaviors, Organ (1988) defines OCB as a set of helpful, discretionary and extra-role behaviors exhibited by employees that are not directly or clearly recognized by the formal reward system and have an overall positive effect on the operation of the organization, also they cannot be enforced by the employment contract. OCB is a matter of individual choice and failure to display such behavior is not generally considered as cause for punishment. Based on this definition, OCB of teachers refers to all voluntary and helping behaviors extended to colleagues, principals, and students (DiPaola, Tarter & Hoy, 2004).

Most scholars agree on the multidimensionality of OCB. Organ (1988) has provided five dimensions including: altruism or helping behaviors, conscientiousness, sportsmanship, civic virtue and courtesy. Some researchers (e.g. Williams & Anderson, 1991) have also divided OCB into two types including behavior that is directed at individual (OCBI) and organization (OCBO) level. Although most scholars agree on the multidimensionality of OCB, in two

---

\* Hassanreza Zeinabadi. Tel.: +98-912-323-6202; fax: +98-21-261-455-1024.

E-mail address: [zeinabadi\\_hr@tmu.ac.ir](mailto:zeinabadi_hr@tmu.ac.ir).

separate factor analytic studies, DiPaola and Tschannen-Moran (2001) found that one dimension captures all aspects of OCB in schools.

Determining antecedents of OCB has attracted a considerable amount of research. Based on a review of the OCB literature, Podsakoff, MacKenzie, Paine and Bacharach (2000) have identified various antecedents including individual, task and organizational characteristics along with leadership behaviors. Previous studies frequently concentrated on the first four categories. Podsakoff et al. (2000) also identified two main categories of individual characteristics including employees' attitudes and dispositional variables. Organ and Ryan's (1995) meta-analysis of 55 studies showed those employees' job attitudes; especially job satisfaction and organizational commitment can predict OCB better than dispositional variables. There is considerable support for the relationship between job satisfaction and OCB (e.g., Bateman & Organ, 1983; Organ, 1988; Williams & Anderson, 1991; Schappe, 1998; Ngunia, Slegers & Denessen, 2006). It is reasonable to suggest that job satisfaction would be positively related to OCB. Employees who are satisfied from his/her job generally reciprocate with positive behavior, including OCBs. A commonly accepted definition of job satisfaction is offered by Locke (1976) as "a pleasurable or positive emotional state resulting from the appraisal of one's job and job experience" (p. 1304). Following the Herzberg's two-factor theory, researchers have studied job satisfaction as a global concept and as a concept with two facets including intrinsic job satisfaction (degree of satisfaction an employee receives from the job itself) and extrinsic job satisfaction (degree of satisfaction an employee has with work conditions, policies and praise which are unrelated to the job itself) (Chiu & Chen, 2005).

Along with job satisfaction, organizational commitment is frequently cited as a antecedent of OCB (Schappe, 1998; Schaubroeck & Ganster, 1991; Ngunia et al., 2006). It is argued that committed employees are more likely to engage in behaviors that enhance their value and support the organization. Thus, a positive relationship between organizational commitment and OCB is reasonable. Organizational commitment is the strength of an individual's identification and involvement in a particular organization as characterized by a strong belief in and acceptance of the organization's goals and values (value commitment) along with a readiness to exert considerable effort on behalf of the organization and to remain a member (commitment to stay) (Mowday, Steers & Porter, 1979; Angle & Perry, 1981). Researchers have also studied, defined and measured organizational commitment as a global and two facets concept (Angle & Perry, 1981; Ngunia et al., 2006).

Despite of evidences which indicate job satisfaction and organizational commitment are significant correlates of OCB, the nature of casual relationships between them is still doubtful and investigations have yielded opposing conclusions. It is due to the complex links between job satisfaction and organizational commitment. A positive relationship between job satisfaction and organizational commitment has been consistently reported by studies (e.g., Shin & Reyes, 1995; Shann, 1998; Currivan, 1999; Testa, 2001). But it is not clear whether job satisfaction is a precursor to organizational commitment or whether organizational commitment influences one's level of job satisfaction. Majority of research has studied job satisfaction as an antecedent to organizational commitment (e.g., Shin & Reyes, 1995; Mathieu, 1991; Gaertner, 1999; Testa, 2001). There is also evidence indicating that high levels of organizational commitment cause job satisfaction (e.g., Bateman & Strasser, 1984; Poznanski & Bline, 1997). Also in predicting OCB, job satisfaction and organizational commitment have been studied both as an outcome and an antecedent variable to each other (Currivan, 1999; Van Scotter, 2000; Ngunia et al., 2006). Despite of the dominant view in the literature which supports the causal precedence of satisfaction over commitment and majority of the researchers which studied and found OCB as an outcome of job satisfaction (e.g., Van Scotter, 2000; Ngunia et al., 2006), the causal direction of these variables is still questionable. This doubt for studying OCB of teachers is more than investigations in non educational settings. While the OCB literature in non educational settings is expansive, there are few documented accounts of any casual relationship between job satisfaction, organizational commitment and OCB of teachers. The evidence suggests that OCB is context specific that is varying from one type of organization to another (Organ, 1988). Behavior in schools is different from that found in non educational settings. Schools are service organizations staffed by teacher professionals who are generally committed to doing what is best for their clients (DiPaola & Hoy, 2004). So the nature of job attitudes influence on teacher's OCB maybe is different from those obtained in other organization.

Previous research on OCB clearly indicates that global job satisfaction and organizational commitment has a positive influence on OCB. But very little research exists regarding the effects of specific facets of job satisfaction and organizational commitment on OCB especially on OCB of teachers. Previous research (e.g., Fisher, 1980) suggests that specific job satisfaction measures should be used to measure specific behavior. Despite of arguments

which emphasize on facets of job attitudes, it is not clear which facets can better predict OCB. Rather than using measures of global job satisfaction and organizational commitment, one could focus on the relationship between specific facets to OCB. It can reveal new understanding about antecedents of teacher's OCB.

A review of the OCB literature in schools suggests a growing interest in modeling the antecedents of OCB. The purpose of the present study was to investigate the casual relation and also to introduce a model for predicting teachers OCB through testing and comparing 36 models. Using structural equation modeling in 18 models, global organizational commitment and two facets (value commitment and commitment to stay) will be studied as a mediator variable. 9 of models hypothesize fully mediation and 9 of models also hypothesize direct effect of global job satisfaction and two facets on OCB. Also in 18 models, global job satisfaction and two facets will be studied as a mediator variable. 9 of models hypothesized fully mediation and 9 of models also hypothesized direct effect of organizational commitment and two facets on OCB.

## **2. Method**

### *2.1. Participants*

A sample including 652 teachers (352 female and 300 male) and 131 male principals of primary schools in 10 districts which represent northern, southern, western, eastern and central districts of Tehran were selected.

### *2.2. Instrument*

Data were collected through 3 questionnaires. Organizational citizenship behavior scale (OCBS), developed by DiPaola et al., (2004) was used to measure OCB of teachers. The scale consisted of 15 items. Job satisfaction was measured with the 20 items of the shortened Minnesota Satisfaction Questionnaire (MSQ) developed by Weiss, Dawis, England, and Loftquist (1967) to measure overall, intrinsic and extrinsic satisfaction. Organizational Commitment was measured using the Organizational Commitment Questionnaire (OCQ) developed by Mowday et al. (1979). According to Angle and Perry (1981) and Ngunia et al., (2006) OCQ measures two facets including value commitment and commitment to stay. Teachers were respondents to the MSQ and OCQ and principals were respondents to the OCBS. Respondents were asked to describe the extent to which they agree with items on a Likert scale ranging from 1 (strongly disagree) to 5 (strongly agree). The coefficient alphas for overall job satisfaction, intrinsic job satisfaction, extrinsic job satisfaction, overall organizational commitment, value commitment, commitment to stay and OCB were .90, .80, .94, .89, .89, .86, and .94 respectively.

### *2.3. Procedure*

All of items were presented in Persian. The original English version of items were translated into Persian and then back translated into English to ensure meaning equivalence across the two cultures. The two versions were evaluated by two education professors fluent in both languages and the best translated items were selected for inclusion. To ensure that the instruments are readily interpretable for Iranian teachers, pilot surveys were administrated to a sample of primary school teachers and principals in Tehran. Results indicate that translated items were clear and meaningful to the respondents. After developing final version, data were collected at regularly scheduled faculty meetings. In each school, principals and teachers were surveyed individually. Researchers explained the general purpose of the study and assured the confidentiality of all responses.

### *2.4. Data analysis*

Structural equation modeling (using LISREL. version 8.72; Jöreskog & Sörbom, 1993) with maximum-likelihood estimation was used to examine measurement and structural models. As suggested by Anderson and Gerbing (1988), two-step analytic procedure was employed. After analyzing measurement model, structural models were analyzed. According to Hall, Snell, and Foust (1999), item parcels were formed on the basis of factor analysis in order to control for inflated measurement errors and improve the psychometric properties of the variables. A fit

index exceeding .90 and higher suggested by AGFI, GFI and CFI and less than .05 suggested by RMSEA and less than 2 suggested by  $\chi^2/df$  are considered as an adequate to good fit.

**3. Results**

Table 1. Correlation matrix

Variables	1	2	3	4	5	6	7
1. Job satisfaction (JS)							
2. Intrinsic Job satisfaction (IJS)	.82**						
3. Extrinsic Job satisfaction (EJS)	.75**	.27**					
4. Organizational commitment (OC)	.26**	.23**	.19**				
5. Value commitment (VC)	.10**	.17**	.10**	.75**			
6. Commitment to stay (CTS)	.27**	.16**	.26**	.71**	.24**		
7. OCB	.36**	.24**	.25**	.34**	.31**	.19**	

\*\*p<.001

Prior to evaluating structural models, measurement models of variables were analyzed using confirmatory factor analyses (CFA). The resulting measurement models provided an adequate fit to the data. Prior to the analysis of structural models, data screening was performed and data were tested for deviation from normality. Then all of 36 models were tested separately and direct and indirect effects and also fit indexes of them were analyzed. Results indicated that just one model has best fit with observed data. Although the chi-squared value was statistically significant ( $100.44, p < 0.05$ ) but several fit indices were well above .90 (CFI: .99 GFI: .98 AGFI: .97). Also  $\chi^2/df$  was less than 2 (1.97) and RMSEA was less than .05 (.040). In addition to the positive fit indexes, significant standardized path coefficients of  $\beta = .19$  ( $p < 0.05$ ) between intrinsic job satisfaction and value commitment,  $\beta = .30$  ( $p < 0.05$ ) between intrinsic job satisfaction and OCB, and  $\beta = .28$  ( $p < 0.05$ ) between value commitment and OCB, support the hypothesized direct relations in this model. Also results revealed that intrinsic job satisfaction has significant indirect effect ( $\beta = 0.05, p < 0.05$ ) on OCB and relationship between intrinsic job satisfaction on OCB to be partially mediated by value commitment. This model explains .20 of variance of teachers OCB. Figure 1 illustrates this model.

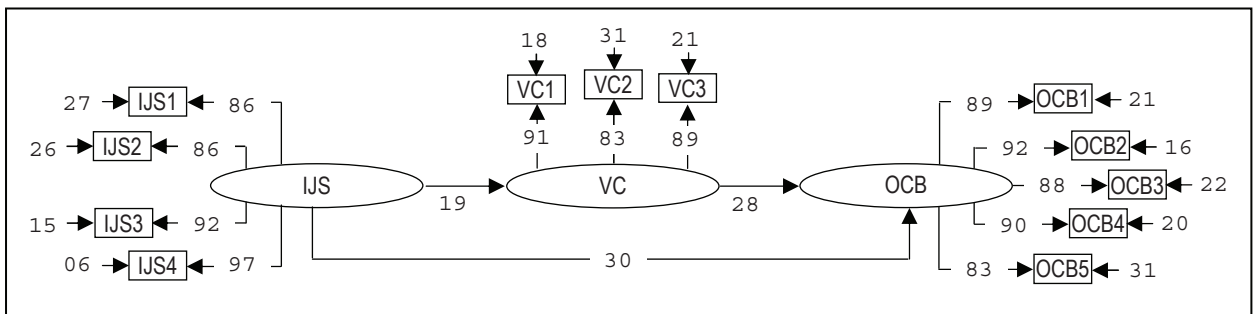

Figure 1. Final model

**4. Discussion**

The results of study initially confirm results of overwhelming previous studies which they have studied job satisfaction as an antecedent to organizational commitment and OCB (e.g., Shin & Reyes, 1995; Mathieu, 1991; Shann, 1998; Gaertner, 1999; Testa, 2001; Currivan, 1999; Van Scotter, 2000; Ngunia et al., 2006). According to Currivan (1999) employee orientation toward a specific job necessarily precede orientation toward the entire organization. Commitment is a more global response to an organization and job satisfaction is more of a response to a specific job or various facets of the job. Job satisfaction is associated with aspects of the work environment and thus would develop more quickly than organizational commitment, which would require a worker to make a more global assessment of his/her relationship to the organization. The result of study is also congruent with "attitude-

intention-behavior" relation model developed by Bagozzi (1992). This model suggests that behavior is a coping activity that results from an individual's appraisal of situation and subsequent emotional response. Job satisfaction represents an appraisal of various facets of the work environment. Organizational commitment is positive emotional response to the positive appraisal of work. Furthermore OCB is a coping activity which emerged as a result of positive emotion. This casual sequence was supported by Testa (2001) by testing a structural model for predicting service efforts.

Other results showed that intrinsic job satisfaction has significant direct effect on OCB. This result is consistent with previous research (e.g., Schnake & Cochran, 1995; Chiu & Chen, 2005) which has found that only intrinsic job satisfaction contributed to OCB. This reveals that motivating intrinsic job satisfaction internally motivates the employee to display positive work behaviors (e.g., OCB) (Organ, 1990). Previous studies on the relationship between job satisfaction and OCB have mainly emphasized overall job satisfaction, and have not separated job satisfaction into different dimensions. The findings of the present study add more knowledge to current understanding of the predictors of OCB especially in educational settings. Research in educational and non educational settings into the effect of intrinsic job satisfaction on OCB via value commitment is missing. Therefore, by having findings on the mediating role of value commitment, current study not only has extended knowledge of explanatory power of intrinsic job satisfaction, but also further confirmed the important mediating role of value commitment on building teachers' OCB. This result is consistent with Ngunia et al., (2006). In their study of primary school teachers, Ngunia et al., (2006) found that job satisfaction has indirect effect on OCB via value commitment. This reveals that motivating intrinsic job satisfaction stimulate teachers' value commitment which, in turn, internally motivates the teachers to display OCB.

The results of this study have several implications for principals and future research. Current findings suggest that principals should emphasis on teacher's intrinsic job satisfaction to promote their value commitment and OCB. They should afford intrinsic rewards (e.g., job meaningfulness, job responsibilities and job challenge) and endeavor to increase teacher's sense of intrinsic satisfaction, rather than offering extrinsic rewards.

With regard to the number of limitations, this study also has implications for future research. Since most empirical evidence on the effects of job attitudes on OCB has been more limited to non educational settings, the present study, therefore, continues and extends this line of inquiry in schools. But the results cannot generalize from this sample (primary schools) to all schools (middle and high schools). Testing final model of study in other schools helps researchers to understand more about model generalize ability. Also this study has limited to the male principals and does not investigate differences between models for male and female teachers. Analyzing gender specificity of structural relations is important to know more about model invariance across two genders. Other limitations should be considered when interpreting the findings of study. Job satisfaction and organizational commitment are self report measures in this study. Although self-report data are usually used to measure job attitudes, researcher should take into account that they may not reflect the actual attitudes of the respondents. In addition, this study viewed OCB as a single factor. The multidimensional approach may provide a better understanding of teacher's OCB and its antecedents.

## References

- Anderson, J. C., & Gerbing, D. W. (1988). Structural equation modeling in practice: A review and recommended two-step approach. *Psychological Bulletin*, 103, 411-423.
- Angle, H. L., & Perry, J. L. (1981). An empirical assessment of organizational commitment and organizational effectiveness. *Administrative Science Quarterly*, 26(1), 1-14.
- Bagozzi, R. P. (1992). The self regulation on attitudes, intentions, and behavior. *Social Psychology Quarterly*. 55(2), 178-204.
- Bateman, T. S., & Organ, D. W. (1983). Job satisfaction and the good soldier: The relationship between affect and employee citizenship. *Academy of Management Journal*, 26, 587-595.
- Bateman, T. S., & Strasser, S. (1984). A Longitudinal Investigation of the Antecedents of Organizational Commitment. *Academy of management Journal*, 27, 95-112.
- Chiu, S. F., & Chen, H. L. (2005). Relation between job characteristics and Organizational Citizenship Behavior: The mediating role of job satisfaction. *Social behavior and personality*, 36(6), 523-540.
- Curri van, D. B. (1999). The causal order of job satisfaction and organizational commitment in models of employee turnover. *Human Resource Management Review*, 9(4), 495-524.
- DiPaola, M., & Hoy, W. K. (2004). Organizational citizenship of faculty and achievement of high school students. *The High School Journal*, 88, 16-45.



- DiPaola, M. F., & Tschannen-Moran, M. (2001). Organizational citizenship behavior in schools and its relationship to school climate. *Journal of School Leadership*, 11, 424-447.
- DiPaola, M. F., Tarter, J. C., & Hoy, W. K. (2004). *Measuring Organizational Citizenship in Schools: The OCB Scale*. Information Age Publishing, Charlotte, NC.
- Fisher, C. (1980). On the dubious wisdom of expecting job satisfaction to correlate with performance. *Academy of Management Review*, 5(4), 607-12.
- Gaertner, S. (1999). Structural determinants of job satisfaction and organizational commitment in turnover models. *Human Resource Management Review*, 9 (4), 479-493.
- Hall, R. J., Snell, A. F., & Foust, M. S. (1999). Item parceling strategies in SEM: Investigating the subtle effects of unmodeled secondary constructs. *Organizational Research Methods*, 2(3), 233-256.
- Jöreskog, K. G., & Sörbom, D. (1989). *LISREL 7: A guide to the program and applications*. (2nd ed.). SPSS, Chicago, IL.
- Katz, D. (1964). The motivational basis of organizational behavior. *Behavior Science*, 9, 131-133.
- Locke, E. A. (1976). The nature and causes of job satisfaction. In M. D. Dunnette (Ed.), *Handbook of industrial and organizational psychology* (pp. 1293-1349). Chicago: Rand McNally.
- Mathieu, J. L. (1991). A cross-level nonrecursive model of the antecedents of organizational commitment and job satisfaction. *Journal of Applied Psychology*, 76, 607-618.
- Mowday, R. T., Steers, R. M., & Porter, L. W. (1979). The measurement of organizational commitment, *Journal of Vocational Behaviour*, 14(2), 224-247.
- Ngunia, S., Slegers, P., & Denessen, E. (2006). Transformational and Transactional Leadership Effects on Teachers' Job Satisfaction, Organizational Commitment, and Organizational Citizenship Behavior in Primary Schools: The Tanzanian case. *School Effectiveness and School Improvement*, 17(2), 145-177.
- Organ, D. W. (1990). The motivational basis of organizational citizenship behavior. *Research in Organizational Behavior*, 12, 43-72.
- Organ, D. W., & Ryan, K. (1995). A meta-analytic review of attitudinal and dispositional predictors of organizational citizenship behavior. *Personnel Psychology*, 48, 775-802.
- Organ, D. W. (1988). *Organizational Citizenship Behavior: The Good Soldier Syndrome*. Lexington Books, Lexington, MA.
- Podsakoff, P. M., MacKenzie, S. B., Paine, J. B., & Bacharach, D. G. (2000). Organizational citizenship behaviors: a critical review of the theoretical and empirical literature and suggestions for future research. *Journal of Management*, 26, 513-63.
- Poznanski, P. J., & Bline, D. M. (1997). Using structural equation modeling to investigate the causal ordering of job satisfaction and organizational commitment among staff accountants. *Behavioral Research in Accounting*, 19, 154-165.
- Schappe, P. (1998). The influence of job satisfaction, organizational commitment, and fairness perceptions on organizational citizenship behavior. *The Journal of Psychology*, 132(3), 277-290.
- Schaubroeck, J., & Ganster, D. C. (1991). Beyond the call to duty: A field study of extra-role behavior in voluntary organizations. *Human Relations*, 44, 569-582.
- Schnake, M., Cochran, D., & Dumler, M. (1995). Encouraging organizational citizenship: The effects of job satisfaction, perceived equity and leadership. *Journal of Managerial Issues*, 7(2), 209-221.
- Shann, M. H. (1998). Professional commitment and satisfaction among teachers in urban middle schools. *Journal of Educational Research*, 92(2), 67-74.
- Shin, H. S., & Reyes, P. (1995). Teacher Commitment and Job Satisfaction: A Causal Analysis. *Journal of School Leadership*, 5(1), 22-39.
- Testa, M. R. (2001). Organizational Commitment, Job Satisfaction and effort in the Service Environment. *The Journal of Psychology*, 135(2), 226-236.
- Van Scotter, J. R. (2000). Relationships of task performance and contextual performance with turnover, job satisfaction, and affective commitment. *Human Resource Management Review*, 10(1), 79-95.
- Weiss, D. J., Dawis, R. V., England, G. W., & Lofquist, L. H. (1967). *Manual for the Minnesota Satisfaction Questionnaire*. Minneapolis: University of Minnesota.
- Williams, L. J., & Anderson, S. E. (1991). Job satisfaction and organizational commitment as predictors of organizational citizenship and in-role behavior. *Journal of Management*, 17, 601-617.