

Transmission Systems

Joint turbo equalisation and carrier synchronisation for SC-FDE schemes

Rui Dinis^{1,2*}, Teresa Araújo^{1,3}, Pedro Pedrosa^{1,4} and Fernando Nunes^{1,4}

¹*Instituto de Telecomunicações, Avenida Rovisco Pais, 1049-001, Lisbon, Portugal*

²*FCT-UNL, Monte da Caparica, Portugal*

³*ISEP, Porto, Portugal*

⁴*IST, Lisbon, Portugal*

SUMMARY

In this paper we consider the use of single carrier (SC) modulations combined with frequency-domain equalisation (FDE) in future broadband wireless systems. We propose iterative receiver structures with joint equalisation and carrier synchronisation. The proposed receivers can be regarded as modified frequency-domain turbo equalisers where we perform a decision-directed frequency offset estimation within each iteration of the turbo equaliser.

Our performance results show that the proposed receiver structure has good bit error rate (BER), even with moderate frequency offsets and in severely time-dispersive channels. Moreover, our receiver has a relatively low implementation complexity, due to its fast Fourier transform (FFT)-based frequency-domain implementation. Copyright © 2010 John Wiley & Sons, Ltd.

1. INTRODUCTION

Due to an increased demand for wireless services, future systems are required to support high quality of service at high data rates. For such high data rates, the time-dispersion effects associated to the multipath propagation can be severe. In this case, conventional time-domain equalisation schemes are not practical. Block transmission techniques, with appropriate cyclic extensions and employing frequency-domain equalisation (FDE) techniques, have been shown to be suitable for high data rate transmission over severely time-dispersive channels without requiring complex receivers. The most popular modulations based on this concept are the orthogonal frequency division multiplexing (OFDM) modulations [1]. Block transmission single carrier (SC) modulations combined with FDE (also denoted SC-FDE), are an alternative approach based on this principle [2].

Although OFDM has very poor uncoded performance [3], the achievable performances with appropriate channel coding are similar for OFDM and SC/FDE [4, 5].

The overall implementation complexities for SC-FDE and OFDM schemes are similar, although the OFDM receivers are slightly simpler and the transmitters more complex. Moreover, the OFDM signals have larger envelope fluctuations which lead to amplification difficulties. Therefore, the OFDM schemes are clearly preferable for the downlink (i.e. the transmission from the base station (BS) to the mobile terminal (MT)) and the SC-FDE schemes are preferable for the uplink (i.e. the transmission from the MT to the BS). For this reason, a mixed SC/OFDM air interface was proposed [4, 6], with an OFDM scheme in the downlink and a SC-FDE scheme in the uplink. In this paper we consider only the uplink transmission of this type of system, i.e. an SC-FDE approach.

A promising iterative FDE (IFDE) technique for SC-FDE, denoted iterative block-decision feedback equaliser (IB-DFE), was proposed in Reference [7]. This technique was later extended to diversity scenarios [5] and layered space-time schemes [8]. These IFDE receivers can be regarded as iterative DFE receivers with the feedforward and the feedback operations implemented in the frequency

* Correspondence to: Rui Dinis, Instituto de Telecomunicações, Avenida Rovisco Pais, 1049-001, Lisbon, Portugal. E-mail: rdinis@ist.utl.pt

Received 17 September 2007

Revised 29 January 2009

Accepted 5 June 2009

domain and offer much better performances than the non-iterative methods [5, 7, 8]. Within these IFDE receivers the equalisation and channel decoding procedures are performed separately (i.e. the feedback loop uses the equaliser outputs instead of the channel decoder outputs). However, it is known that higher performance gains can be achieved if these procedures are performed jointly. An effective way of achieving this is by employing the so-called turbo equalisation schemes where the equalisation and decoding procedures are repeated, in an iterative way, with some soft information being passed between them [9]. Although initially proposed for time-domain receivers, turbo equalisers also allow frequency-domain implementations [10, 11][‡].

In order to maintain high power and spectral efficiencies, the cyclic prefix, which is longer than the overall channel impulse response length, should be a small fraction of the block duration. Therefore, we usually need large blocks for severely time-dispersive channels, with hundreds or even thousands of symbols. Typically, the frequency errors cannot exceed a small fraction of the inverse of the block duration. This means that we have higher sensitivity to frequency errors for larger blocks, making accurate carrier synchronisation mandatory. One source of frequency errors is the frequency mismatch between the oscillators at the transmitter and receiver. Another possible source of frequency errors is the Doppler frequency shift caused by relative motion between the transmitter and the receiver.

The carrier synchronisation is usually performed in two (or more) stages. Typically a coarse synchronisation, with moderate accuracy and large acquisition band, is followed by a fine synchronisation, with high accuracy and small acquisition band (Reference [12], and references therein). The fine carrier synchronisation can be performed after the equalisation procedure, namely using decision-directed estimation. This is especially effective for SC modulations since the frequency offsets produce a progressive constellation rotation and the equalised signal resembles the received signal in flat-fading channels [13, 14].

An alternative to a decision-directed carrier frequency offset (CFO) estimator, is using known sequences with good correlation properties. Although yielding more accurate estimates, this solution requires extra block overhead thus reducing the bandwidth efficiency [15]. Exploring the similarities between the synchronisation requirements of both transmission schemes, it is possible to use, in SC-FDE schemes, the frame structure of training symbols originally

designed for synchronisation purposes in OFDM schemes. In Reference [16], Moose proposed a maximum-likelihood (ML) CFO estimator, based on the use of two identical and consecutive symbols, with a frequency acquisition range $\pm 1/(2T)$, where T is the ‘useful’ symbol duration. This result was later extended in Reference [17], which uses also two symbols; the first estimates the fractional part of the CFO ($|\Delta f| < 1/T$), whereas the second symbol resolves the frequency ambiguity inherent in the first symbol, i.e. it estimates the integer part of the CFO (Δf multiple of $1/T$). Morelli and Mengali proposed in Reference [18] an algorithm exploiting a training symbol with $L > 2$ identical parts. Its estimation range is $\pm L/2$ times the subcarrier spacing and its accuracy is slightly superior to that of the Schmidl and Cox method. Its main advantage is that it needs just one training symbol while the Schmidl and Cox method needs two symbols. In Reference [19], Morelli and Mengali improved this estimation technique using algorithms that achieve the Cramer–Rao bound at the cost of increased complexity. A comparison between different designs for the frame structure of the pilot symbols is made in Reference [20]. Besides pilot tone-aided algorithms, other techniques, like cyclic-prefix estimation, may be applied to track the frequency offset (see, for instance, Reference [21]).

In this paper we consider an SC-FDE block transmission in the presence of residual frequency errors. We propose a receiver structure with joint equalisation and carrier synchronisation. We consider iterative receivers that can be regarded as modified frequency-domain turbo equalisers where we perform decision-directed frequency offset estimation within each iteration of the turbo equaliser.

This paper is organised as follows. The basic iterative FDE receivers are described in Section 2. Section 3 presents the modified receivers with joint equalisation and carrier synchronisation. A set of performance results is presented in Section 4 and Section 5 is concerned with the conclusions.

2. ITERATIVE FDE RECEIVERS

2.1. Receiver structure

For the sake of simplicity, we will assume in this section that there is perfect carrier synchronisation. Figure 1(A) presents the iterative frequency-domain receiver structure considered in this paper. It is assumed that we have L receiver antennas, i.e. we have L -order space diversity. The received time-domain block associated to the l th antenna, $\{y_n^{(l)}; n = 0, 1, \dots, N - 1\}$, is passed to the frequency domain by a DFT operation, leading to the block

[‡] The IFDEs of References [5, 7, 8] (or IB-DFEs) can be regarded as special types of frequency-domain turbo equalisers with reduced complexity, since the channel decoder is not required in the feedback loop.

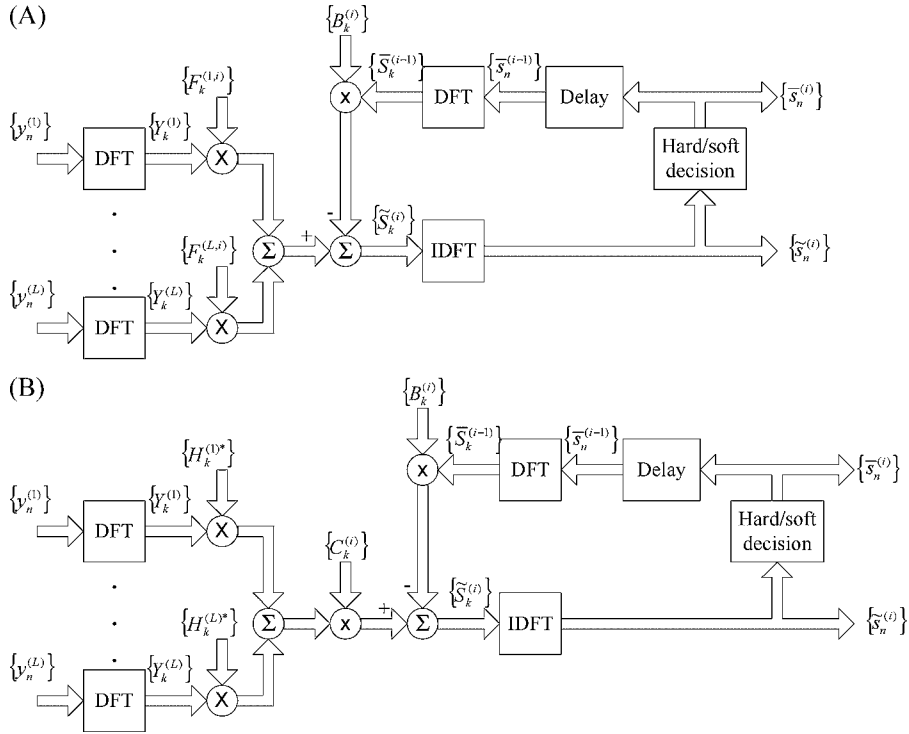

Figure 1. (A) IFDE receiver with L -branch space diversity and (B) equivalent receiver structure, since $F_k^{(l,i)} = H_k^{(l,i)*} C_k^{(i)}$, $l = 1, 2, \dots, L$.

$\{Y_k^{(l)}; k = 0, 1, \dots, N - 1\}$, with

$$Y_k^{(l)} = S_k H_k^{(l)} + N_k^{(l)} \quad (1)$$

where $H_k^{(l)}$ and $N_k^{(l)}$ denote the channel transfer function and the channel noise, respectively, for the k th subchannel of the l th diversity branch. The block of frequency-domain symbols $\{S_k; k = 0, 1, \dots, N - 1\}$ is the DFT of the transmitted time-domain block, $\{s_n; n = 0, 1, \dots, N - 1\}$, with s_n denoting the n th data symbol to be transmitted, selected from a given constellation (e.g. a QAM or a PSK constellation).

For a given iteration i , the frequency-domain samples at the output of the FDE are given by[§]

$$\tilde{S}_k^{(i)} = \sum_{l=1}^L F_k^{(l,i)} Y_k^{(l)} - B_k^{(i)} \bar{S}_k^{(i-1)} \quad (2)$$

where $\{F_k^{(l,i)}; k = 0, 1, \dots, N - 1\}$ ($l = 1, 2, \dots, L$) are the feedforward coefficients and $\{B_k^{(i)}; k = 0, 1, \dots, N - 1\}$ are the feedback coefficients. $\{\bar{S}_k^{(i-1)}; k = 0, 1, \dots, N - 1\}$ denotes the DFT of the block of time-domain average symbol values associated to the previous iteration, $\{s_n^{(i-1)}; n = 0, 1, \dots, N - 1\}$. The method for obtaining these average values is described in Section 2.2.

It can be shown that the optimum feedback coefficients are [5, 7]^{||}

$$B_k^{(i)} = \sum_{l=1}^L F_k^{(l,i)} H_k^{(l)} - 1 \quad (3)$$

and the feedforward coefficients are given by

$$F_k^{(l,i)} = \frac{\tilde{F}_k^{(l,i)}}{\gamma^{(i)}} \quad (4)$$

[§] Our IFDE receiver is slightly different from the IB-DFE receivers of References [5] and [7], since there the correlation factor is incorporated in the feedback coefficients.

^{||} Contrarily to References [5] and [7], we are considering normalised equalisers, i.e. $\frac{1}{N} \sum_{k=0}^{N-1} \sum_{l=1}^L F_k^{(l,i)} H_k^{(l)} = 1$.