

Received August 26, 2020, accepted August 27, 2020, date of publication September 14, 2020, date of current version October 1, 2020.

Digital Object Identifier 10.1109/ACCESS.2020.3023802

Key Challenges, Drivers and Solutions for Mobility Management in 5G Networks: A Survey

IBRAHEEM SHAYEA¹, **MUSTAFA ERGEN¹**, **MARWAN HADRI AZMI²**,
SULTAN ALDIRMAZ ÇOLAK³, **ROSDIADEE NORDIN⁴**,
AND YOUSEF IBRAHIM DARADKEH⁵

¹Electronics and Communication Engineering Department, Faculty of Electrical and Electronics Engineering, Istanbul Technical University (ITU), 34469 Istanbul, Turkey

²Wireless Communication Centre, School of Electrical Engineering, Faculty of Engineering, Universiti Teknologi Malaysia (UTM), Johor Bahru 81310, Malaysia

³Department of Electronics and Communication Engineering, Faculty of Engineering, Kocaeli University, 41380 Kocaeli, Turkey

⁴Department of Electronics, Electrical and System Engineering, Universiti Kebangsaan Malaysia, Bangi 43600, Malaysia

⁵Department of Computer Engineering and Networks, College of Engineering at Wadi Addawasir, Prince Sattam Bin Abdulaziz University, Wadi Addawasir 11991, Saudi Arabia

Corresponding author: Ibraheem Shayea (ibr.shayea@gmail.com)

This work was supported in part by the 2232 International Fellowship for Outstanding Researchers Program of the Scientific and Technological Research Council of Turkey (TÜB TAK), Istanbul Technical University (ITU), under Project 118C276, in part by the Universiti Teknologi Malaysia, Higher Institution Centre of Excellence (HICOE), under Grant R.J130000.7851.4J413, and in part by the Ministry of Higher Education (MOHE) through the Fundamental Research Grant Scheme (FRGS)-Universiti Teknologi Malaysia under Grant R.J130000.7851.5F177.

ABSTRACT Ensuring a seamless connection during the mobility of various User Equipments (UEs) will be one of the major challenges facing the practical implementation of the Fifth Generation (5G) networks and beyond. Several key determinants will significantly contribute to numerous mobility challenges. One of the most important determinants is the use of millimeter waves (mm-waves) as it is characterized by high path loss. The inclusion of various types of small coverage Base Stations (BSs), such as Picocell, Femtocell and drone-based BSs is another challenge. Other issues include the use of Dual Connectivity (DC), Carrier Aggregation (CA), the massive growth of mobiles connections, network diversity, the emergence of connected drones (as BS or UE), ultra-dense network, inefficient optimization processes, central optimization operations, partial optimization, complex relation in optimization operations, and the use of inefficient handover decision algorithms. The relationship between these processes and diverse wireless technologies can cause growing concerns in relation to handover associated with mobility. The risk becomes critical with high mobility speed scenarios. Therefore, mobility issues and their determinants must be efficiently addressed. This paper aims to provide an overview of mobility management in 5G networks. The work examines key factors that will significantly contribute to the increase of mobility issues. Furthermore, the innovative, advanced, efficient, and smart handover techniques that have been introduced in 5G networks are discussed. The study also highlights the main challenges facing UEs' mobility as well as future research directions on mobility management in 5G networks and beyond.

INDEX TERMS Mobility management, handover, mobility challenges, handover problems, mobility robustness optimization, handover self-optimization, load balancing, 5G network, and future ultra-dense networks.

I. INTRODUCTION

Practical implementation has begun for the first phase of the Fifth Generation (5G) network at the global level, while plans for the second phase (mm-wave 5G) are currently in progress. Generally, there are three different use-cases in 5G networks: enhanced Mobile Broadband (eMBB), massive Machine-Type Communications (mMTC), and Ultra-Reliable Low-Latency Communication (URLLC). Each of them possesses

challenging requirements such as providing wider coverage, increased network capacity, high reliability or providing minimum delay. It is clear that each 5G use-case requires different handover strategies, which affect the signaling overhead, power consumption, and handover delay. The implementation of the 5G networks will potentially impact mobile phones compared to previous generations.

5G allows for a wide variety of connections such as the Internet-of-Things (IoT), Machine-To-Machine (M2M), Device-To-Device (D2D), Vehicle-To-Everything (V2X), and Bluetooth. Collectively, they will influence businesses,

The associate editor coordinating the review of this manuscript and approving it for publication was Robert Hunjet.

governments, and customer interactions in the physical world [1]–[9]. Connections are significantly growing with time due to the recognized benefits of linking inert devices to the internet by customers, businesses, and governments. Over the next decade, these aforementioned services will be key components of the largest device markets in the world [10]–[12]. It is expected that there will be hundreds of thousands of simultaneous connections deemed essential for the massive deployment of these services in 5G networks [13]–[15]. These varied types of connected services will require more system capacity and higher data rates, while parts of them require lower latency. All these have led to the development of the 5G systems.

Currently, new studies and plans for the Sixth Generation (6G) have begun; systems that mainly aim to provide massive capacity, high data rates, lower latency, lower battery consumption, and reduced cost versus 4G systems [13], [14], [16], [17]. However, high data rate demands require a very wide bandwidth to meet and fulfill User Equipments (UEs) satisfaction. The required bandwidth for a 5G system is ten times higher than what is required for the 4G system [13], [14], [16]–[19]. This high demand is the key factor for proposing the use of millimeter waves (mm-waves) since wider bandwidths are available in these bands [20], [21]. These bands are located between 10 GHz and 300 GHz [20]. The bands of 10 GHz to 86 GHz spectrum have been recommended by the International Telecommunication Union (ITU) [22], numerous industries [23], and many research centers [21] as the best candidate bands for the 5G system [21]–[23]. They have also been studied in several research categories [24]. The 28 GHz and 38 GHz are currently the most recommended band for the 5G system [25]–[32]. Meanwhile, other higher mm-wave bands of up to 120 GHz are recommended for the 6G system [13]–[15].

Although 5G technology based on mm-wave bands will provide several solutions and features, numerous issues related to mobility management have emerged. Therefore, future mobile cellular communication networks will become more complicated than previous networks. Several drivers have contributed to the increasing complexities related to mobility management. First, the use of the mm-wave will lead to the deployment of massive numbers of small Base Stations (BSs) due to the small coverage that can be provided by the mm-wave. That will significantly contribute to the increase of handover probability. In addition, the implementation of Dual Connectivity (DC) with Carrier Aggregation (CA) will cause several handover scenarios. This is due to the ability to simultaneously assign multiple Component Carriers (CCs) frequency bands for one UE. One CC is usually defined as a Primary Component Carrier (PCC), while the other CCs are defined as Secondary Component Carriers (SCCs). The PCC is responsible for carrying the control data, while the SCCs are used for further data. The UE can make handover between carriers to change the PCC. Multiple handover procedures over multiple CCs are needed when the UE moves

from one cell to another, further increasing the handover probability.

The massive growth of mobile connections, network diversity, and emerging Three-Dimensional (3D) mobile communication (such as drones) will lead to a radical increase in the demand for mobile data. Serving large numbers of UEs will require the deployment of massive amounts of small, overlapping BSs. This will lead to the structuring of ultra-dense systems in future networks. Collectively, these determinants will significantly contribute to the increase of the unbalancing load and handover probability. On top of all these factors, the use of inefficient handover techniques will further raise mobility issues, leading to a high increase in the Handover Probability (HOP), Handover Failure Probability (HFP), Handover Ping-Pong Probability (HPPP) effect, Radio Link Failure (RLF), interruption time, and throughput degradation. The handover failure will then increase due to the small cell size, especially with higher mobility speed scenarios. This is because UEs with high mobile speeds may cross the cell within a few seconds, and this will reduce the probability of making handover decisions and/or the completion probability of the handover procedure.

Handover and its related issues will deteriorate mobile connectivity, connection reliability, and stability during the UE's mobility. Addressing these matters requires more advanced, robust, and efficient mobility protocols, handover techniques, and system solutions. The design of mobility management protocols, handover parameters self-optimization techniques, load balancing models, coordination functions, handover decision algorithms, handover procedure, and path prediction methods are needed. Although several mobility solutions were proposed for 4G systems, they will not be fully efficient in 5G networks. New solutions must be effectively designed to deal with future networks characterized by more advanced specifications and requirements than previous networks.

Recently, a few studies have focused on mobility management issues in terms of mobility prediction, autonomic vertical handover, security, Software-Defined Network (SDN), Software Defined Network Virtualization (SDNV), Network Function Virtualization (NFV), and battery consumption models [33]–[38]. On top of that, a survey based on real measurement data conducted shown how Long-Term Evolution-Advanced (LTE-A) network performs during the mobility of users in comparison with the first phase of LTE releases. That study has analyzed handover execution time, coverage and latency [39]. However, each study provided a survey from a different perspective. Therefore, an overview study is needed to highlight the determinants of mobility challenges, issues, mobility solutions, and future directions for upcoming networks.

This paper presents a comprehensive review and state-of-the-art in mobility management for the 5G networks. The previous works on mobility management and its characterizations in the 5G networks are reviewed and discussed. This study also focuses on the drivers that cause mobility issues in the 5G networks. Understanding the root cause of

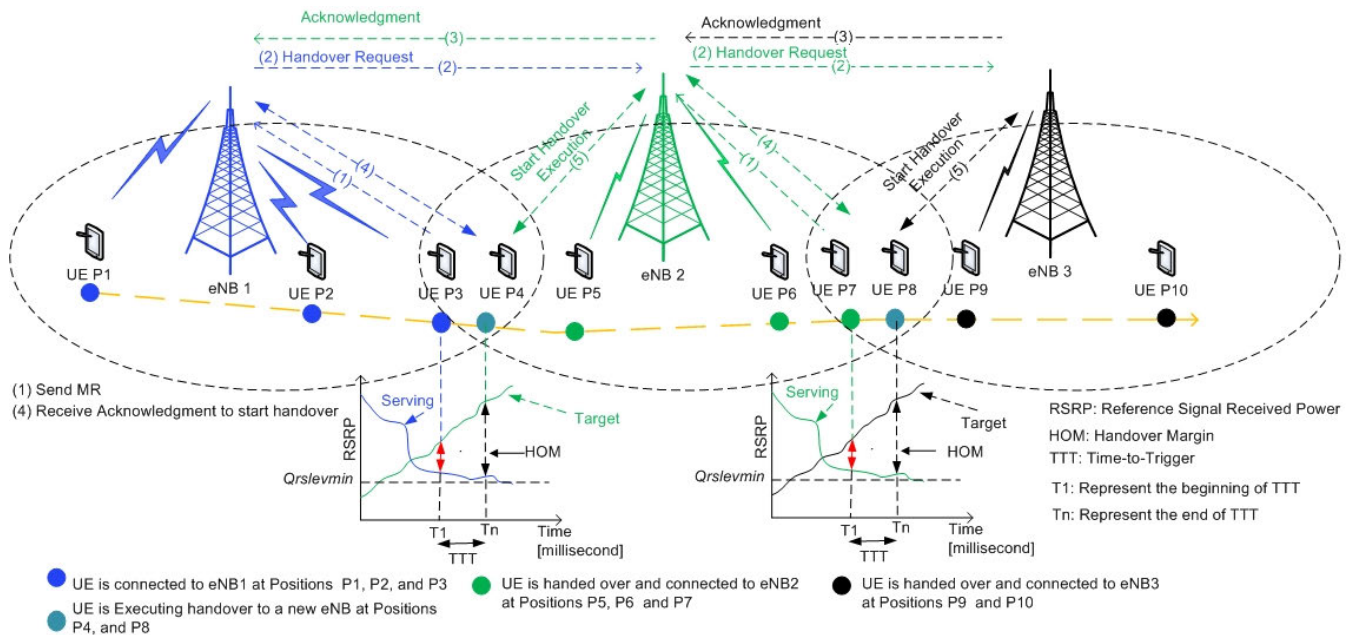

FIGURE 1. Mobility management with handover initiation in wireless communication networks.

the issues will contribute towards the development of more efficient mobility solutions. Opportunities and solutions that can be considered in the development of 5G networks are also highlighted. An overview of challenges and practical issues to be addressed in 5G networks is provided. We hope that this critical review may lead researchers to innovate, design, and formulate efficient and smart handover techniques that can manage handover optimization, handover decisions, dual handover, and seamless handover procedures for 5G networks and beyond.

The rest of this paper presents the following: Section II provides an overview on mobility; Section III presents and discusses key drivers of mobility challenges; Section IV provides a brief description of advanced mobility solutions; Section V discusses mobility challenges and future trends in 5G networks; and Section VI presents the paper’s conclusion.

II. MOBILITY OVERVIEW

Mobility in wireless networks is fundamentally identified as the ability to maintain a UE’s connection with the serving wireless network during the UE’s movement within cells without any disruption in the ideal case, as shown in Figure 1. It is considered as one of the essential features provided by wireless communication networks as compared to wired networks. With the mobility property, UE can have flexibility during its movements. This feature enables UE to switch its connection during its movement from the first cell (known as a serving BS) to a new cell (known as a target BS) as long as coverage is available. Data can be rerouted from the old serving BS to the new target BS. All these features increase UE satisfaction and facilitate the wide availability of wireless services at any time and for many purposes. The movement of UE leads to a continuous change in the received signal

strength level. Once the received signal strength falls below an acceptable level or below the Received Signal Strength Indicator (RSSI), which is the received signal strength threshold level, at any specific location, a handover procedure is triggered, as illustrated in Figure 1. The procedure begins by sending a request from the serving to the target BSs to switch the UE’s connection to the target BS that provides a good signal strength. Therefore, the UE connection will be maintained with the serving networks during mobility without any disruption in the ideal case. But, mobility can only be supported by systems that support mobility functions.

Mobility functions are essential roles for mobility support in wireless communication networks. They are the functions that are responsible for enabling the mobile UE to switch connections from one cell to another during movement without any disruption in the ideal case. Several mobility functions are present, such as the mobile Internet Protocol (IP), handover decision, handover optimization functions [40]–[42], and rerouting mobile protocols [43]–[45]. Some wireless networks support these functions, while others do not. For example, cellular systems, wide-area mobile data systems (i.e., Mobile WiMAX), Wireless Local Area Networks (WLAN), and several satellite systems support mobility functions. On the other hand, cordless networks, fixed wireless networks (i.e., fixed WiMAX), some satellite systems (satellite TV services), radio, and Bluetooth systems do not support mobility functions. In addition to supporting mobility functions, the system maintains different maximum mobility speeds depending on the wireless system and its specifications.

Mobility speed is one of the significant criteria considered in mobility studies for wireless networks. Numerous UEs can have different speeds, which lead to dissimilar impacts on the received signal strength during UE mobility.

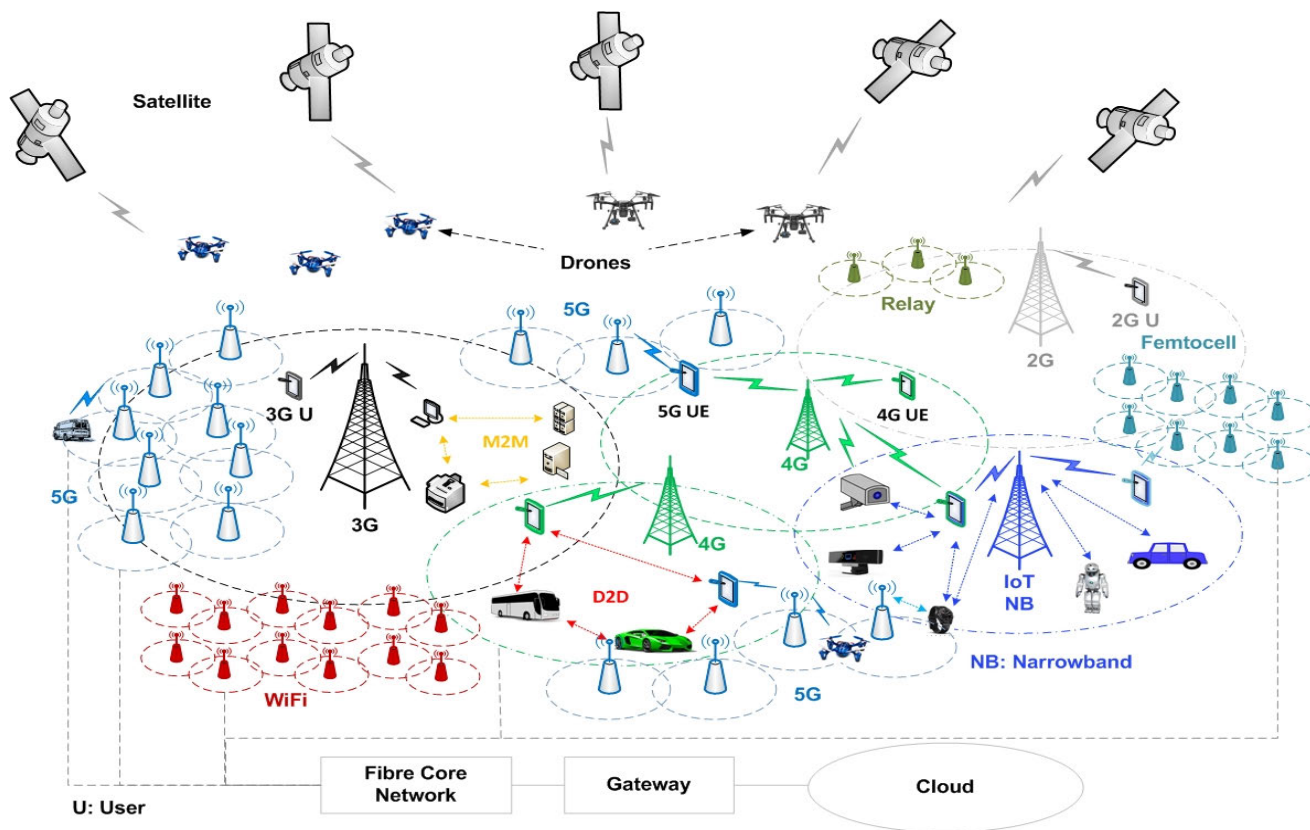

FIGURE 2. Ultra-dense and overlapping HetNets with multi-types of connections in future wireless networks.

That, in turn, can lead to various effects on communication stability. The maximum user speeds supported by wireless communication systems with mobility features vary. For instance, in 4G, the supported maximum speed was only 350 km/hr [46], while the 5G cellular system can support up to 500 km/hr [47]. As the maximum speed is increased, fast handover decision making as well as carrying out the required handover process becomes essential requirements. Supporting a specific mobility speed is an essential requirement that must be fulfilled for each wireless system, specifically mobile cellular systems. The reason behind that is due to several key factors in the system’s architecture, protocols, and functionalities employed; such as round communication latency, network architecture, the applied frequency, and node processing time. Although new wireless systems support higher mobile speeds, the increase in mobile speed leads to critical issues during mobility. As a result, several mobility techniques have been proposed to address the various issues that arise during different mobile speed scenarios.

Efficient mobility techniques mean the mobility procedures, methods, mechanisms, and protocols that work efficiently to support a reliable and stable connection during UEs’ mobility [38], [48]–[52]. Various mobility techniques and functions have been presented to support mobility. One example would be the techniques used for regulating mobility control parameters, known as handover self-optimization

functions [50], [51], [53]–[58]. Another example is the mechanisms used for making handover decisions, known as handover decision algorithms [59]–[63]. Protocols are also applied for rerouting data or voice calls to the new routing path, known as mobile routing protocols [64], [65].

The techniques utilized for reducing handover probability, handover delay, or improving handover procedure can also support mobility. Implementing efficient mobility techniques will lead to seamless connections throughout UE mobility within cells. This will guarantee a reliable connection and provide excellent quality service. Several techniques have been proposed in the literature for addressing mobility issues. However, at present, there is no optimal mobility technique that can fully address all mobility issues. Thus, these concerns are still an open area of research for new systems, such as 5G or 6G technologies.

In 5G technology, the use of mm-waves [19], [20] is the predominant factor affecting mobility. That occurs due to the high path loss when mm-wave frequency bands are employed thereby the cell coverage reduces. This leads to a significant increase in the handover probabilities, which leads to increased mobility problems, such as high handover failure, handover Ping-Pong effect, and radio link failures. Moreover, new types of mobile connection systems are expected to be established in future networks, as presented in Figure 2. Implementing these systems will contribute to the increase of mobility issues as well.

The tremendous growth of mobile UEs will lead to congestions in the serving network. That will raise the overlapping network deployments, especially of small BSs, which in turn will raise the handover necessities. Collectively, these issues will lead to a future increase in mobile data traffic. This rapid growth will also contribute to the high probability of handover rate. Handover interruption time is another critical issue that will occur in 5G networks since the 5G cell size is incredibly small and the handover probability will be very high, leading to a significant increase in the interruption time. Thus, the handover processing time must be very short, especially for the UEs with high speed.

III. KEY FACTORS FOR MOBILITY CHALLENGES

This section will highlight twelve (12) key factors that can influence the mobility management in 5G networks.

A. IMPLEMENTATION OF THE mm-WAVE

In the near future, a massive number of small 5G BSs will be deployed to build upcoming HetNets. However, communication performance will be radically affected. This is due to the introduction of the mm-wave bands which provide very short coverage due to their high path loss characterization [21], [66]–[70]. For example, 28 GHz is one of the best candidate frequency bands that can be implemented in 5G networks, but this frequency band can only support up to 200 meters in Line-Of-Sight (LOS) [71], [72]. To cover an area of a few kilometers by the 5G networks, a high number of small 5G BSs must be deployed, compared to the previous generations. Numbers will further rise with the use of higher mm-wave bands since the coverage will become smaller. Compared to the 4G system based on 2.1 GHz, one 4G cell can cover up to 1.5 km [73]–[78]. On the other hand, replacing one 4G cell with 2.1 GHz by a 5G cell with 28 GHz will require more than fourteen 5G cells to provide similar coverage as one 4G. The large massive numbers of small 5G cells will lead to a high number of handover probabilities during UEs’ mobility, which, in turn, will lead to a high increase in the probability of HPPP effect, RLF, interruption time, and throughput degradation. Given the larger number of required handovers (due to this smaller cell size), the expected number of handover failures in the network also increases. The case becomes more critical with higher mobility speed scenarios. This is because mobile UEs with high mobile speed scenarios can cross the cell within a few seconds, and this will reduce the proper searching time needed and the completion probability of the handover procedure. Therefore, the introduction of mm-waves for future networks will be one of the drivers that will cause significant mobility issues.

B. DUAL CONNECTIVITY (DC)

DC enables UEs to have connectivity to two different cells at the same time [79]–[86]. One connection is established to a macro cell and another to a small cell [87]. The UE can simultaneously perform communication over the 4G and 5G networks, as illustrated in Figure 3. This contributes to

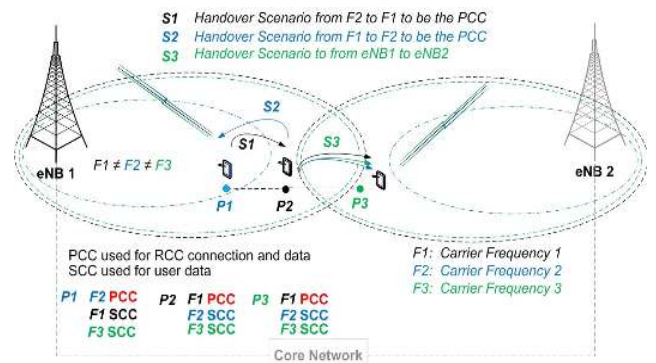

FIGURE 3. Dual Connectivity with handover scenarios in future communication networks.

enhancing UE’s data rate and mobility performance. Since the UE can be connected to 4G and 5G networks over different frequency bands at the same time, the handover scenarios obviously will increase. This will cause additional handover probability since new handover scenarios will be added compared to a single connection. These new handover scenarios occur in two situations: (i) when the UE switches the connection of the microcell to another macro cell, (ii) when the UE switches the connection from a small cell to another small cell. This will lead to an upsurge in handover probability, causing further increases in mobility problems. That includes interruption time, signaling overhead, and battery life wastage.

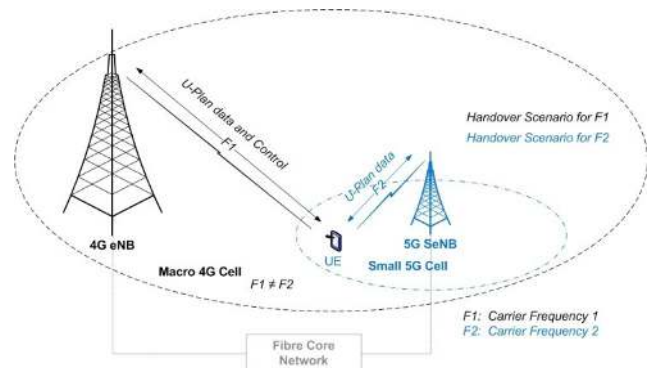

FIGURE 4. Dual Connectivity with handover scenarios in future communication networks.

C. CARRIER AGGREGATION

The carrier aggregation technique has been introduced in LTE-A systems. It began from Rel.10 and was further developed to Rel.16. The basic notion of the CA technique is aggregating multiple CCs to serve one UE, as shown in Figure 4. That enables the UE to establish multiple connections with the serving BS over different frequency bands simultaneously. This has been targeted so as to achieve a higher data rate over an effectively wider bandwidth. The CA technique aims to enhance wireless connectivity by offering better coverage. One of the assigned carriers is

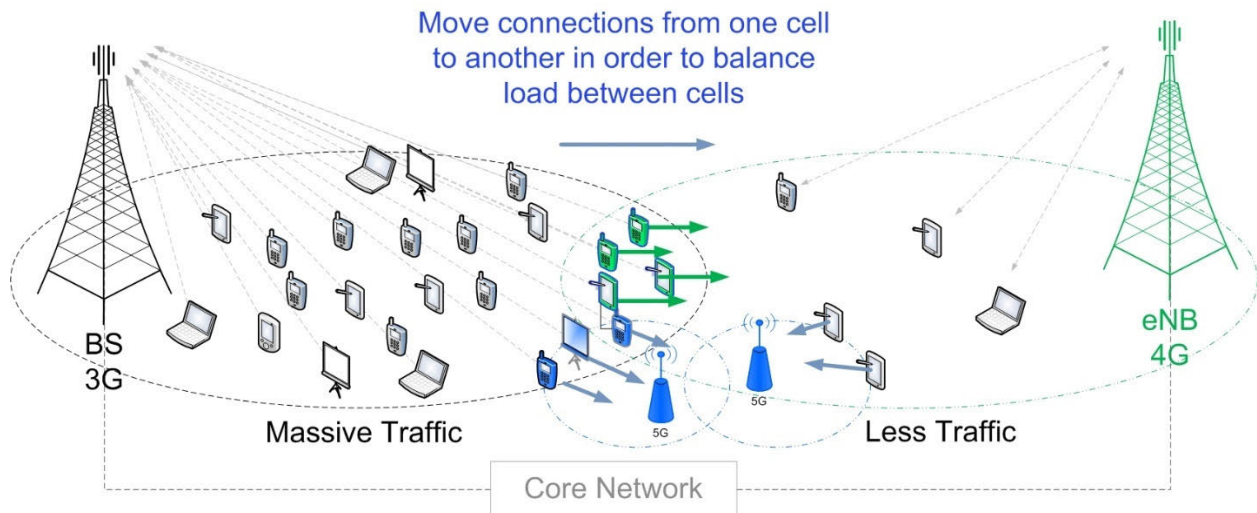

FIGURE 5. Growth of mobile communication leads to increased load balancing needed in future communication networks.

permanently configured as a PCC used to transfer the control data between the UE and the serving network. The other assigned carriers are always configured as SCCs to extend the UE's bandwidth and deliver further data. In other words, the key difference between the assigned PCC and SCCs is the type of data transmitted over each carrier.

The aim of introducing the CA technique with different Carrier Aggregation Deployment Scenarios (CADSs) is to boost the total network performance by offering wider bandwidth to UEs, improving network coverage, and enhancing the overall UE experience. However, from a technical perspective, implementing this technique with various CADSs will add new mobility challenges. Configuring multiple CCs to serve one UE will prompt new handover scenarios. One handover scenario that can be performed is between CCs, which is defined as the CC to CC handover scenario. That occurs when the system needs to change the PCC, which is selected as the best among multiple configured CCs.

This new handover scenario aims to switch the PCC, which mainly takes place according to the signal quality, and channel conditions related to the UE behavior as well as Handover Control Parameter (HCPs) settings. Another handover scenario occurs when inter-base station handover is taken place. Since the UE communicates using multiple CCs, the handover needed is over PCC and SCC switching connections to new BSs through the support of the CA technique. That will lead to a rise in handover probability, which will further contribute to increasing the probability of mobility issues.

D. GROWTH OF NETWORK DIVERSITY

In the 1990s, the Second Generation (2G) cellular networks were able to serve mobile UEs over wireless links. Subsequently, the WLAN began, followed by WiMAX, for offering data services. Concurrently, 3G networks started to deliver

data services but with limited speeds compared to WLAN or WiMAX during that time. Today, several wireless networks can serve UEs with different types of services: voice, data, or video. Currently, mobile UEs can communicate over 2G, 3G, 4G, 5G, WLAN, or Mobile WiMAX networks based on coverage and resource availability. These different types of wireless networks are deployed, overlapping each other. This enables the connected UE to switch connections between the different types of networks during its movement. Although it will allow the wide availability of wireless communication resources and services, it also contributes to the rise in handover probability. This will further add to the probability of increased mobility issues.

E. MASSIVE GROWTH OF MOBILE DEVICES

The growing number of mobile connections is another significant problem facing the implementation of future cellular networks [88]. The massive increase in mobile connections will lead to a radical increase in the demand for mobile data traffic, which means a wider bandwidth is needed [88]. Since the system bandwidths provided by 3G and 4G BSs are limited and insufficient, they will not be able to serve a high number of UEs within the cell. The 5G will be deployed while overlapping 3G and 4G networks. Therefore, part of the 3G and 4G mobile connections will be switched to 5G cells *in order to balance the load and reduce the traffic congestion* of 3G and 4G networks [89], as shown in Figure 5. This will lead to a tremendous increase in the handover probability from 3G and 4G to 5G BSs. The effect will be more critical with the massive number of connections that will be implemented in future networks. The growth of these various connected devices can contribute to additional mobility issues. Thus, the rising number of various connected devices over different links is one scenario that will increase the cell load. Subsequently, this will add to the request for

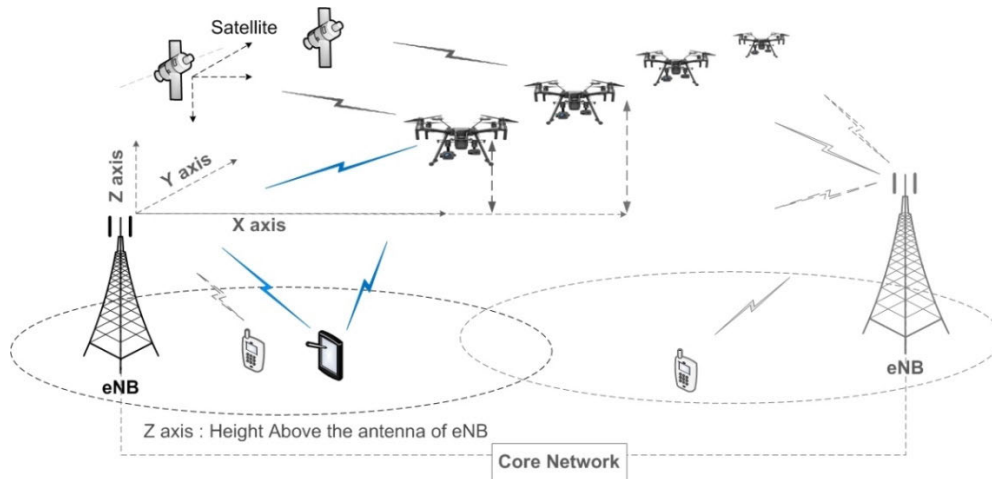

FIGURE 6. Connected drones with 3D movement in future networks.

balancing loads in some cases. As a result, a significant rise in the handover rate will occur.

F. EMERGING 3D MOBILE COMMUNICATION

Connected drones are anticipated to be used in 5G networks and beyond. Currently, the target is to use connected drones to serve as sky BSs, or act as mobile UEs when employed for other services. Recently, Loon company has started to deliver wireless connectivity with the balloon-based base station. This project is expected to initiate the move towards enhancing data rates to UEs, which will lead to providing good wireless services in a remote area. Similarly, they are expected to be used in several other services [90]–[93]. However, connected drones require more stable communications. But, the movement of drones or any aerial objects in three dimensions is a key challenge as it leads to rapid change in the received signal strength [90], [94]–[96]. Moreover, the mobility speed of drones is faster and their trajectories are different than that of vehicles or normal UEs, further resulting in rapid degradation of the received signal strength. This, in turn, contributes to the rise in handover probability. The handover processing time to switch connections to a target BS will require time, and that may cause some calls to get dropped before the drones can switch connections. Therefore, these issues will further increase the interruption time more than what occurs typically to UEs.

G. ULTRA-DENSE NETWORK

Overlapping deployment in future HetNets is another concern that may become a mobility issue. 5G networks will be deployed overlapping the current HetNets (2G, 3G, and 4G networks) as well as future IoT networks. Femtocells and mesh Wi-Fi will also be widely deployed and overlapping cellular networks, as illustrated in Figure 7. All networks are expected to serve mobile UEs, and handover can be performed from one network to another. Since future HetNets will become more overlapping, and ultra-dense,

the types of handover scenarios will also increase. This will also significantly contribute to soaring handover rates during UEs' mobility, which will increase the handover probability, causing a significant escalation in HFP, HPPP effect, RLF, interruption time, throughput degradation, as well as overhead and overall communication performance quality [79]–[83], [86], [97]–[105]. The drawbacks become more severe through high mobility speeds, particularly when there are no mobility robustness optimization techniques or efficient handover decision algorithms used. Thus, these issues must be addressed as well in the design of mobility management.

H. INEFFICIENT OPTIMIZATION PROCESS

Proposing methods to optimize HCP settings is necessary for improving overall system performance. Typically, the UE performs handover based on a set of HCPs estimated in the system and assigned to all UEs. The optimal handover decision algorithm triggers the handover request when the HCP criteria are met. Thus, optimizing the HCP settings is one of the key approaches for enhancing mobility performance in 5G networks.

If HCP settings are adjusted to fixed settings, ongoing communication will be negatively affected, especially when the UE speed is substantially high. Thus, HCP settings should be suitably adjusted to address this shortcoming. However, performing this manually will increase management and maintenance complexity. Therefore, the Handover Parameter Optimization (HPO) function has been introduced by the 3rd Generation Partnership Project (3GPP) as a fundamental feature in the deployment of 4G and 5G networks [40]–[42], [106]. This function automatically estimates the appropriate HCP settings according to the instantaneous network conditions. Subsequently, several studies have been conducted to address this shortcoming [48]–[50], [55], [81], [107].

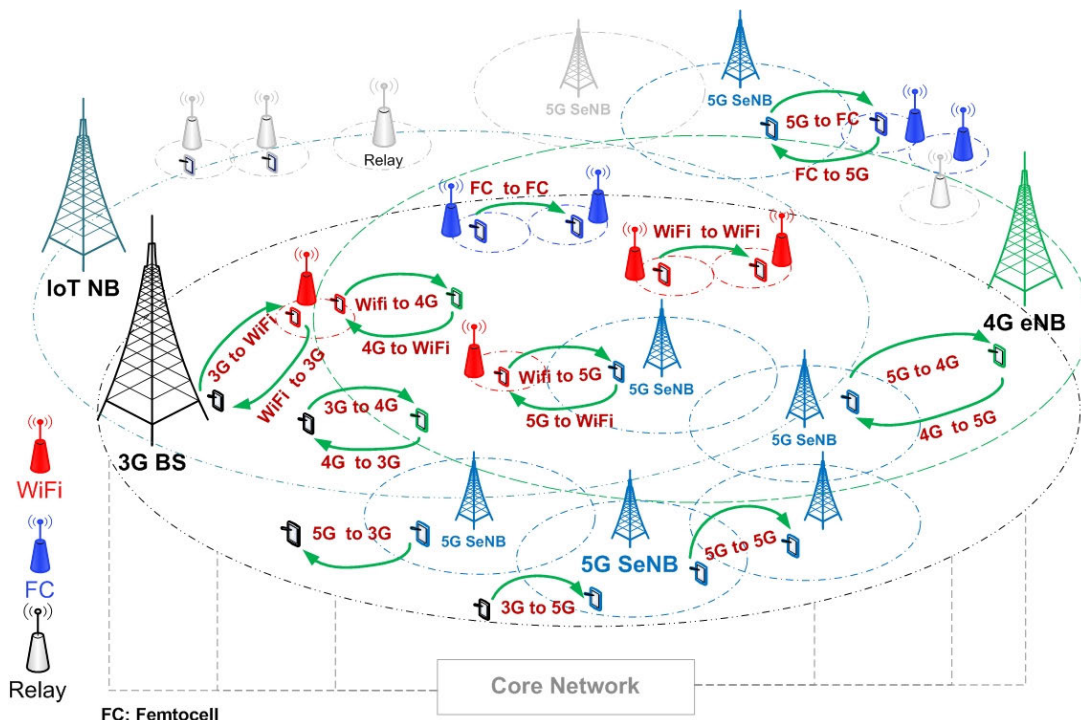

FIGURE 7. Probabilities of handover scenarios in Ultra-Dense networks without carrier aggregation and dual connectivity.

According to existing studies in the literature [48]–[50], [55], [81], [107], algorithms that provide efficient optimization for HCP settings are available, but no optimal solution exists. Some proposed algorithms only adjust HCP settings according to a single parameter, such as distance or velocity. Since several influencing factors should be considered for estimating appropriate HCP settings (such as distance, channel condition, noise, interference, resource availability, and UE’s velocity), simply approximating these configurations from the perspective of a single factor will only lead to inadequate HCP settings. Some of these algorithms, such as the Adaptive Handover Algorithm, are based on distance (AHOA-D) [108], velocity [109], and a Fuzzy Control (FLC) algorithm [110]. The FLC algorithm only adjusts the Handover Margin (HOM) level, while the Time-to-Trigger (TTT) is set to a fixed value. This malfunction reduces the main purpose of the HPO task.

All highlighted algorithms perform optimization for each cell except AHOA-D. This may allow some UEs to perform handover to other cells, while not needing the handover procedure at that time. Therefore, unnecessary handover probability will increase as a result of suboptimal HCP settings. Studies that focus on optimizing HCP settings based on multiple influencing factors are lacking. It can be stated that only non-robust and suboptimal algorithms are present for selecting appropriate HCP settings in the next mobile networks. Most of these algorithms have been developed for 4G technology, which has different specifications and requirements than what is needed for 5G networks. The existing algorithms developed for previous cellular networks

may be inefficient for use in 5G networks. Thus, they must be investigated over 5G networks with different mobility and deployment scenarios. Then, the validated algorithm(s) can be recommended or further developed to become applicable in 5G networks. There is a need for advanced, dynamic, and robust HPO algorithms that estimate appropriate HCP settings based on multiple influencing parameters.

I. CENTRAL SELF-OPTIMIZATION OPERATION

One of the main issues related to mobility is the optimization operation for HCPs. Several algorithms have been developed to automatically perform self-optimization for HCPs [56], [110]–[122]. To the best of our knowledge, the most available self-optimization algorithms were designed based on the concept of central control and optimization for all systems. That means the optimization operation is performed based on the performance of the entire network, and not on an individual UE’s experience. That entails using unified HCP settings for all UEs, simultaneously.

All UEs connected to a specific BS must utilize the same HCPs. This central optimization may lead to increased handover issues for some UEs. Not all mobile UEs require the optimization process to perform at the same time and in the same direction. Some UEs may need optimization at time T, while others may not require optimization during that same time. Similarly, some UEs may need optimization in the upper direction at time T, while others may require optimization to be performed simultaneously in a different

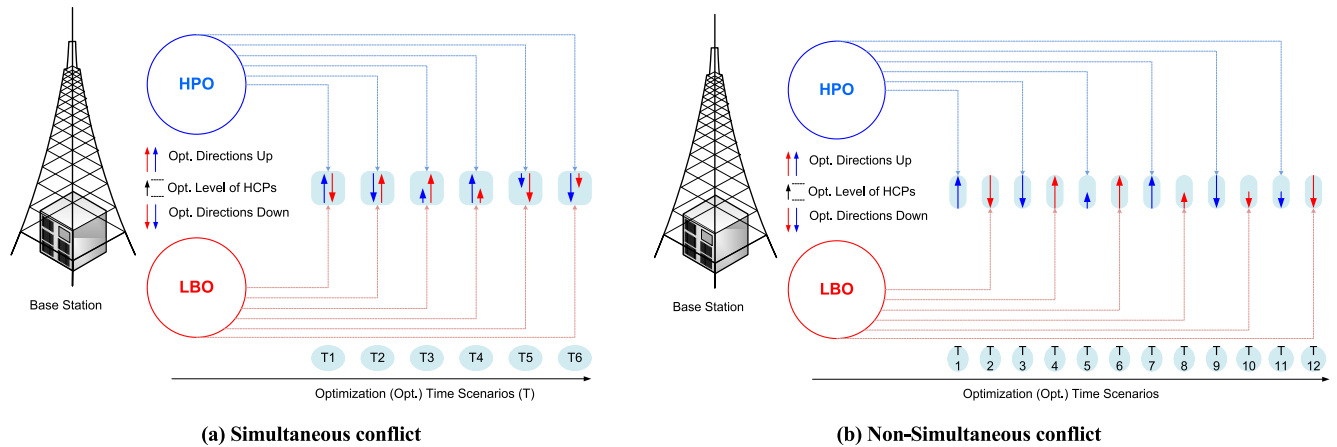

FIGURE 8. The mesh relationships (Conflict Problem) between LBO and HPO algorithms and HCPs.

direction. Thus, a central optimization operation is a critical mobility issue that must be addressed in 5G networks.

The problem becomes more critical due to the small coverage offered by 5G BSs, the support for high mobility speeds, and the need for Ultra-Reliable Communication (URC). Thus, central optimization will not be the best solution for 5G networks. The decentralized and distributed approaches would, therefore, be required.

J. PARTIAL SELF-OPTIMIZATION

Partial self-optimization means the optimization algorithm performs the automatic operation for some selected HCPs only, while the other HCPs are defined statically and manually. This type of optimization can create another handover issue. Some algorithms in the literature operate based on this concept. That is, some algorithms optimize only one HCP (the HOM), such as in [110], [116], [122], while the other HCPs are considered to be fixed. Utilizing fixed TTT may cause one handover issue that HPO aims to address.

K. COMPLEX RELATION IN SELF-OPTIMIZATION OPERATION

The HPO and Load Balancing Optimization (LBO) are two algorithms that optimize system performance by automatically adjusting HCP settings. Both functions aim to dynamically optimize HCP settings to handle various handover problems [40]–[42], [123]. For example, the HPO function adaptively adjusts HCP settings to maintain system quality and perform automatic optimizations for HCPs with minimal human intervention; on the other hand, the LBO function can adaptively adjust HCP settings to balance the load over adjacent cells.

Since these two algorithms adjust the same HCP settings for the same cell, they may be dependent on each other, where the action of one algorithm may have an influence on the other algorithm. This situation is defined by 3GPP as “Self-Optimization Network (SON) functions in conflict” [42], [124]. This conflict can occur when HPO and

LBO functions adjust the same HCP settings in the same direction with different scales or in two opposite directions, as illustrated in Figure 8. This figure shows the different optimization scenarios that may lead to producing conflicts process between the LBO and HPO operations. These can occur simultaneously or in two different periods. Thus, a conflict is detected due to the complex relationship between these algorithms. This conflict can be classified as two different types: (i) a simultaneous conflict and (ii) a non-simultaneous conflict. If HPO and LBO algorithms perform optimization at the same time, the simultaneous conflict occurs, as illustrated in Figure 8 (a). Similarly, if these algorithms perform optimization at different times, the non-simultaneous conflict occurs, as illustrated in Figure 8 (b).

Consequently, HCP settings will be modified twice. This parallel optimization process produces problems and the network behavior becomes unstable. As a result, one of these two algorithms will be unable to achieve the specified SON objectives since they may have conflicting interests on network resources. This complex relationship and the emergent issues that arise through the interplay of these two procedures is a key cause contributing to increased mobility management issues, especially with the deployment of 5G and 6G systems. Avoiding this conflict is hardly possible unless one of these two algorithms is disabled. However, disabling LBO or HPO algorithm may not satisfy the prerequisite that both load and handover performances must be enhanced simultaneously. Therefore, several coordinated algorithms have been proposed to mitigate, prevent, or resolve this problem [125]–[128]. The main and general concept of the coordinated algorithms is to synchronize the optimization process between LBO and HPO to avoid conflict probability. Although these solutions are aimed at solving the problem, it has not been fully resolved. One of the major reasons for the resulting problem is central optimization. Furthermore, existing solutions perform coordination using a single factor while neglecting other influencing factors. That usually enhances the system performance on one side,

while degrading it on the other side. Therefore, no optimal coordinated solution exists in the literature. Thus, the study of handover coordination is still an open research area. Solving this issue can be performed by developing an efficient and smart coordinated algorithm/function that is able to perform individual optimization for each user independently based on its need.

L. INEFFICIENT HANDOVER DECISION ALGORITHM

The improvement achieved by optimizing HCP settings in HetNets may be hindered without an efficient handover decision algorithm. The importance of implementing an efficient handover decision is equivalent to the optimum estimation of handover decision settings since it is the first line of the handover process. Most works in handover decision algorithms were developed for 3G and 4G networks, however, these technologies offer wider cell coverage than what can be offered by the 5G networks. Moreover, 3G and 4G networks have different requirements and specifications than what is needed for the 5G networks [129]–[131].

The handover scenarios in the 5G networks are further increased due to several factors, as described previously in Figure 7. The small coverage provided by 5G BSs, with high mobility supports and URC requirements, raise the need for more robust and faster handover decision algorithms.

The impact of mm-waves on handover performance is not thoroughly covered in the current literature. This gives an indication that the existing handover decision algorithms employed in 3G and 4G networks may not be efficient for use in 5G networks. The case becomes even more critical with applications that require URC. This is considered as one of the contributing factors that lead to increased mobility issues in 5G networks. Further investigations and developments for handover decision algorithms are needed.

IV. ADVANCED MOBILITY SOLUTIONS

The developments of cellular communication systems offer enhancements and new services; however, several issues usually emerge with new upcoming systems. Fortunately, numerous techniques have risen as solutions to these challenges. There are five (5) available solutions, which will be discussed as follows.

A. HPO MODELS

One significant feature that has been introduced to solve mobility problems in 4G and 5G networks is mobility functions under the SON [42], [57], [84], [106], [132]–[139], which may further be developed and kept as one of the main components in the 6G system as well. The SON feature is one of three main sub-networks that has been introduced under the Self-Organization Network in 4G and 5G networks, as illustrated in Figure 9.

The main aim of the SON is to automate the management process by dynamically adapting system parameters. Automatic adaptation of system parameters is accomplished by integrating a variety of self-optimizing functions to

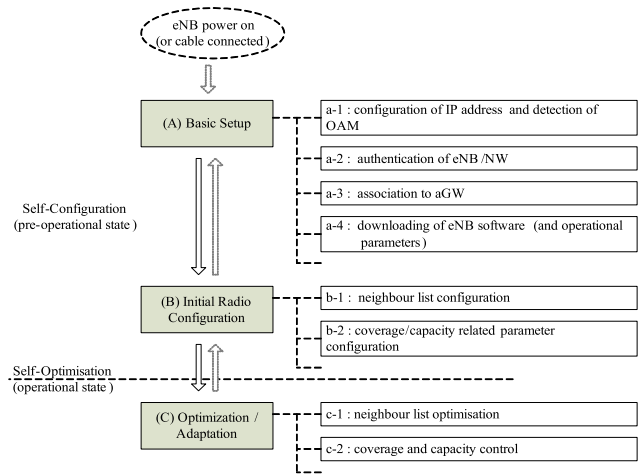

FIGURE 9. The functionality of self-configuration and self-optimization.

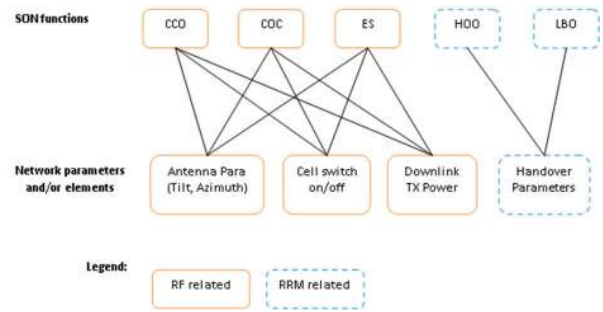

FIGURE 10. Self-Optimization functions and their mesh relationship with network parameters [123].

improve system quality and reduce network complexity. HPO and LBO are among the significant functions (algorithms) introduced in the SON, as illustrated in Figure 10 [42], [84], [85], [106], [132]–[136], [140].

The HPO Function has been introduced as a fundamental feature in the deployment of 4G and 5G networks. Its main aim to automatically tuning HCP settings to maintain network quality. Specifically, HPO’s target is to detect and perform corrections of both the RLF and the HPPP effect due to mobility. In other words, the HPO algorithm adaptively adjusts the HCP settings when RLF or HPPP is detected as a result of one or more of the following causes:

- i). “Too Early Handover”, as described in Figure 11 (a),
- ii). “Too Late Handover”, as described in Figure 11 (b),
- iii). “Handover to Wrong Cell”, or
- iv). “Inefficient use of system resources”, which causes by unnecessary handover.

If RLF or HPPP is detected as a result of suboptimal HCP settings, the HPO algorithm is enabled to adjust HCP settings for the related cell to solve the handover problem. Currently, the mobility within 5G networks (with high requirements such as URLLC, mm-wave, lower latency) has prompted the need for more advanced HPO algorithms. It became

a key requirement that should be developed to address mobility issues adopted in 5G networks. The existing HPO algorithms developed for 4G networks may not be efficient for use in 5G networks. One of the reasons is due to the central optimization operation and in part due to the partial optimization, as they both have been explained previously. Also, some of the current algorithms in the literature use inefficient input parameters in designing the algorithm, which also leads to estimate inappropriate HCP settings.

B. LBO FUNCTION

The LBO function adaptively adjusts HCP settings to balance the unequal load between neighboring cells (see Figure 5). Cell load balance is required when two cells' coverage overlap, two cells' hierarchical coverage overlap, or neighboring cells' coverage overlap, as described in Figure 12. When the loads between these two cells are unbalanced, the LBO algorithm is enabled to adjust the HCP settings of the corresponding cell. This is accomplished to handover the UEs located at the cell edge to the cell that provides more resources and with a lesser load. The operation of the LBO algorithm initially begins by monitoring the cells' load and then exchanges the related information within neighboring eNBs over X2 or S1 interfaces. Based on this information, the load of each cell is indicated to be either low, mid, high, or overloaded. The serving eNB selects the suitable target cell based on the load's indication.

Consequently, the LBO algorithm is enabled when the serving cell becomes overloaded and the load of the selected target cell is less than or equal to the average load. If the serving cell load does not reach the overloaded level, the LBO algorithm will not be enabled. Although this function has been introduced to contribute to solving mobility issues, the need for more efficient LBO algorithms is still required.

C. ENABLING DC

Although DC is one of the factors that lead to increased handover probability, it also contributes to solving mobility issues. In DC, the UE can simultaneously be connected over multiple carriers to two varied BSs of different technologies. This will contribute to providing high data rates to UEs by allowing them to utilize two different bands over two different technologies. Thus, the total UE data rate is the aggregated data rate of the 4G and 5G speeds. A more stable connection is provided since the control data will be managed by macro BSs. Enabling the DC technique contributes to enhancing the UE data rate during mobility as well as reducing the dis-connectivity probability that results from the implementation of small 5G cells. However, the mobility issue will not be solved entirely. Let us assume that the connection can be maintained with the macro BS, and frequent handover can occur over cells that use mm-waves. However, implementing a more optimal solution can efficiently contribute to addressing the issue.

D. CONDITIONAL HANDOVER

Conditional Handover (CHO) is a new technique that has been introduced as a part of mobility functions in 3GPP's Rel.16. Its aim is to enhance the mobility robustness of UEs [142]–[146]. It was defined by 3GPP in [142] as *“a handover that is executed by the UE when one or more handover execution conditions are met”*.

This technique operates based on the concept of advanced preparation for the targeted BSs before the handover is triggered. It seems that CHO has some similarities to the soft handover technique concept with a few changes in the operations and handover features. The technique begins with the advanced preparation of a list of neighboring BSs to be the candidate target BSs before the UE's serving Reference Signal Received Power (RSRP) goes below the threshold level and before the handover is needed. Once the handover is needed, the serving BS will be ready to perform the handover since the candidate target BS was already specified in advance. In other words, for CHO, the serving BS will be able to list and prepare multiple BSs as candidate target BSs before the handover is triggered. Implementing this technique will enable the UE to receive the handover acknowledgment early before the handover is needed. This will contribute to reducing handover delay and speed up the handover procedure as it will be taken beforehand as compared to the usual case.

This technique specifically aims to decrease the occurrences of handover failure, which leads to the reduction of the interruption time. CHO contributes to reducing the need for the re-establishment procedure. The handover can be performed instead of enabling the re-establishment procedure when the handover failure is recorded. This is because for a while, the mobile UE can store the handover commands for multiple target BSs. That will enable the BS to select another candidate target BS to perform the handover to it instead of enabling the re-establishment procedure. That will lessen the interruption time. On the other hand, CHO will contribute to increasing the signaling overhead and buffering storage since the mobile must establish monitoring in advance, while sometimes it may not be needed [147], [148]. Further investigations are required.

E. DUAL ACTIVE PROTOCOL STACK HANDOVER

The Dual Active Protocol Stack (DAPS) is a proposed solution introduced by Ericsson to mainly contribute to reducing the interruption time during UE's mobility [149]. The key characteristics of this proposed solution are:

- i). Continuous communication through the serving BS after the handover request is received,
- ii). Enabling the UE to receive the UE data from the serving and target BSs simultaneously.
- iii). Uplink transmission of UE data switched to target BS after the random-access procedure.

Figure 13 provides a general description of this proposed solution. Once the UE receives the request to execute the

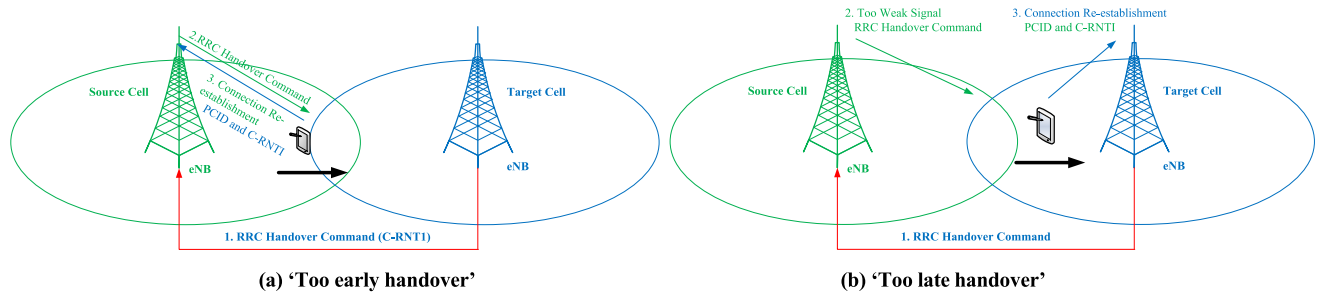

FIGURE 11. Handover problems due to suboptimal HCP settings [141].

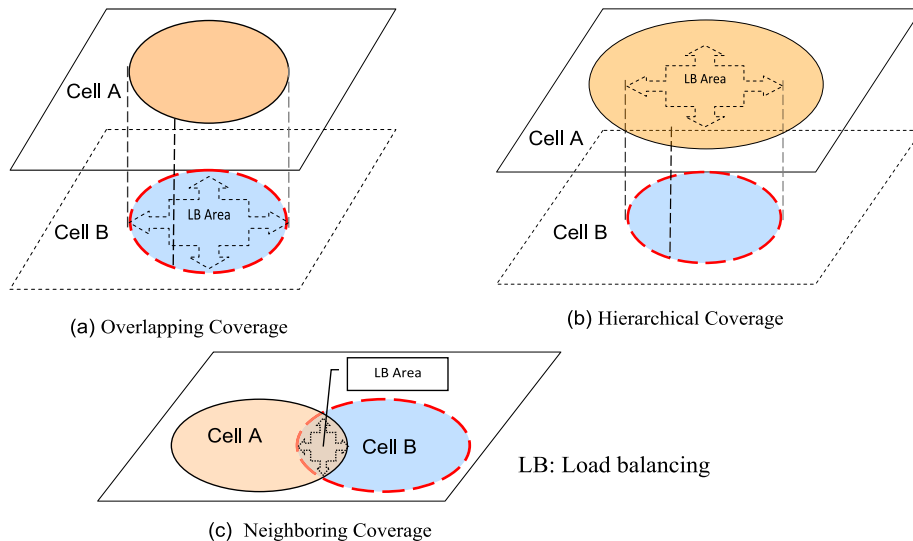
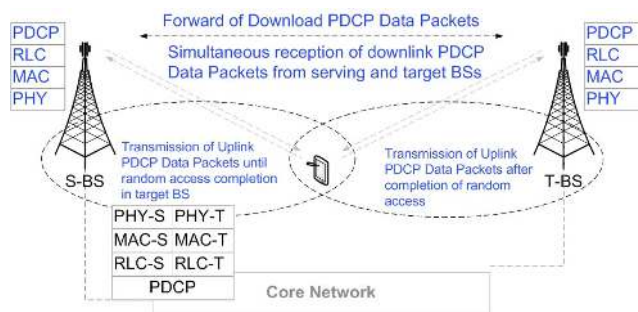

FIGURE 12. Coverage scenarios for balancing load between cells [42].



Phy: Physical, MAC: Medium Access Control, RLC: Radio Link Control
 PDCP: Packet Data Convergence Protocol, S: Serving, T: Target

FIGURE 13. The DAPS concept for reducing interruption time that results from handover [149].

handover procedure, it continues to send and receive UE data in the serving BS. Simultaneously, the UE establishes a new connection for synchronizing random access to the target BS. There are no simulation or measurement results that have been published for this solution. Thus, further investigations should be carried out.

V. CHALLENGES AND FUTURE TRENDS

The discussed determinants will create numerous mobility issues and challenges. Although several techniques have been

introduced in 5G networks to address mobility management issues, there is no solution that can optimally solve all mobility problems in future heterogeneous and homogeneous networks. Moreover, not all proposed solutions have been investigated in 5G networks. Therefore, no guarantee is present on whether or not they can all work efficiently in future networks. Most were designed and validated in previous networks (such as 4G, 3G, and 2G networks), which use frequency bands below 5 GHz, while 5G networks will implement mm-wave bands. Innovating, designing, and developing advanced, efficient, and smart handover self-optimization models and handover decision algorithms for HetNets are clear requirements for future practical networks. The drivers of mobility challenges discussed in the previous sections lead to the emergence of several mobility issues that must be addressed in future HetNets. This section will examine eight (8) challenges and future research trends in mobility management.

A. HIGH HANDOVER PROBABILITY

The advent of mm-wave bands, DC, CA, drones, massive IoT, D2D, M2M, V2X connections and other factors will collectively cause additional handover scenarios, more than those found in previous HetNets. Moreover, the huge increase in mobile connections, emergence of new network types, and

deployment of ultra-dense networks will be other significant factors that can raise handover probability. Additionally, the use of inefficient optimization processes and handover decision algorithms are further factors that can increase handover probability. As a result, a significant rise in HFP, HPPP effect, RLF, and interruption time will take place. These will subsequently lead to a high reduction in UEs' spectral efficiency and throughput. As a consequence, high interruption time will occur, which may lead to increased service disruptions and overall network quality.

B. NON-OPTIMAL HANDOVER PARAMETERS SELF-OPTIMIZATION FUNCTION

The risk of mobility problems will further rise if suboptimal HCP settings are assigned. As previously discussed, there is no optimal optimization technique available yet that can thoroughly address all the optimization issues perfectly. This will also lead to an obvious increase in the handover probability, HPPP, HFP, and RLF. The central and partial optimization processes are some factors that contribute to non-optimal optimization. The input parameters used for the designed algorithms are other factors that require careful selection and design. This indicates that a more optimal algorithm is highly needed. Thus, it becomes necessary to have more advanced and robust handover self-optimization algorithms that can estimate accurate HCPs.

C. NON-EFFICIENT LOAD BALANCING SELF-OPTIMIZATION FUNCTION

The number of connections has massively increased, and the types of wireless networks have further risen. These will lead to the deployment of ultra-dense networks consisting of various technologies that overlap each other, causing an upsurge in the load balancing operation. The matter will become more critical in the future as the growing number of connected UEs rapidly increases. This signifies the need for smarter load balancing self-optimization algorithms.

D. CONFLICT OPTIMIZATION ISSUE

The optimal solution for LBO and HPO functions consists of complex relations and their conflicting problems. The massive number of mobile connections and ultra-overlapping dense networks in future networks will increase the operations of HPO and LBO functions. An escalation in conflicting operations of these two functions will mostly lead to increased HPO, HPPP, HFP, and RLF, which all contribute to more interruption time. Collectively, significant degradation in network throughput, spectral efficiency, and network quality will take place. Thus, developing smart automatic coordination models are necessary for future cellular networks to coordinate between the operation of HPO and LBO functions.

E. INEFFICIENT HANDOVER DECISION

The current handover decision algorithms will not guarantee efficient performance with mm-wave networks. Feature requirements and specifications of future cellular

networks prompted the need for more efficient handover decision algorithms. Designing **an efficient handover decision algorithm** is another key factor that can contribute to solving mobility problems. An efficient handover decision algorithm is a significant functionality that can control the handover rate, unnecessary handover, and RLF; it is the essential step of the handover procedure between serving and target cells.

Since an efficient handover decision algorithm contributes to providing a seamless connection between the UE and serving network, it should be effectively designed to perform and produce a proper handover decision for the suitable target cell. In the literature, several handover decision algorithms have been introduced to enhance further handover performance [59], [60], [81], [150]. These algorithms were designed based on various parameters that have been investigated in different wireless systems. Therefore, exploring various handover decision algorithms in future HetNets will be crucial for improving UE experiences. Although robust HPO and efficient LBO algorithms will lead to enhanced system performance, more effective handover decisions are also required [53], [60], [151].

F. MACHINE LEARNING (ML) AND ARTIFICIAL INTELLIGENCE (AI)

Enabling Machine Learning (ML) and Artificial Intelligence (AI) to be part of the solutions for addressing mobility issues will be a significant advantage [152]–[156]. This can be performed by designing ML/AI algorithms that can automatically learn from the recorded experiences of users during their mobility. This will enable the system to perform the self-optimization and handover procedures faster and accurately at the correct place and time. Similarly, this technology can be used to enable the system to learn how and when to make the balance, as well as which UEs specifically require the optimization process. Likewise, ML can be used to detect and address the conflict operation issue that may occur between HPO and LBO functions.

G. INTERRUPTION TIME FOR URLLC

Interruption time is a critical matter that must be addressed in 5G networks. It mainly results from an unstable connection between the UE and the serving network. The surge in the execution of handover leads to increased interruption time. During handover execution, the mobile UE cannot receive the data plan until this period is complete. This interval is known as an interruption time. It also occurs when the handover failure is recorded, and a re-establishment connection is triggered. In the case where the Radio Resource Control (RRC) connection re-establishment or Non-Access Stratum (NAS) procedure is triggered, the interruption time increases.

In 5G networks, minimizing interruption time will become more crucial, especially with the critical remote control use-cases. Some examples of remote use-cases include remote robot surgery, smart remote manufacturing, connected drones, connected vehicles, and other more critical cases that

are remote-controlled by wireless networks. These remote and critical control cases require URLLC to serve efficiently.

It is essential that high communication reliability with very low end-to-end latency must be secured. For that, one of the main future targets for 3GPP Rel.17 and beyond is to introduce more advanced features that could efficiently support remote and critical use-cases through mobility.

H. SIGNALING OVERHEAD

The signaling overhead will be higher in 5G networks due to the use of DC, CA, CHO, and mm-wave. Utilizing DC and CA will enable UEs to simultaneously communicate with the serving BS over multiple carriers. The case becomes worse if DC and CA are implemented together in one serving network. This is because the UE will simultaneously have connections over multiple carriers. That will further increase handover scenarios as well as signaling. Collectively, these issues will raise signaling overhead problems. Further studies regarding future networks must be conducted to successfully address these issues.

I. BATTERY LIFE CONSUMPTION

The use of mm-wave, DC, CA, and the increase in handover probability, and signaling overhead will altogether increase the power consumption of the UE's battery. Efficient battery use remains an outstanding challenge in 5G technology and it is a goal that must be achieved. 5G technology is aiming for a 100× battery life increase, as compared to 4G technology. Achieving this target requires advanced techniques that can work more efficiently. Although several studies have been conducted regarding this target [157]–[160], the issue still requires further research studies.

VI. CONCLUSION

In future mobile cellular systems, several determinants are presented, which are expected to cause additional mobility issues. The main key factors include the use of mm-wave bands, Dual Connectivity (DC), Carrier Aggregation (CA), the massive growth of mobile communication & devices, increase in the network diversity, the emergence of drones as UEs/BSs in the sky, ultra-dense networks, inefficient optimization process, central optimization operation, partial optimization, complex relation in optimization operation, and the inefficient handover procedures that are inherent based on the current design and algorithms.

The emergence of various mobile networks, such as IoT, M2M, D2D, and V2X are additional factors that contribute to the increase of mobility issues. Collectively, these will lead to a vast surge in the handover rate, where several critical issues will occur, such as the rise in HFP, HPPP effect, and RLF during UEs' mobility. The interruption time, throughput degradation, and cell edge spectral efficiency degradation will subsequently increase. Although several solutions have been proposed for addressing mobility problems, no optimal solution that can fully solve the issues in 5G networks exists. Thus, researchers and developers must address these technical problems and fully tackle mobility challenges to

ensure practical and seamless mobility management in the current and beyond 5G cellular systems.

APPENDIX

See Table 1.

TABLE 1. List of abbreviations in alphabetical order.

Item	Description
2G	2nd Generation Mobile Networks
3G	3rd Generation Mobile Networks
3GPP	3rd Generation Partnership Project
4G	4th Generation Mobile Networks
5G	5th Generation Mobile Networks
6G	6th Generation Mobile Networks
AHOA-D	Adaptive Handover Algorithm Based on Distance
AI	Artificial Intelligence
BS	Base Station
CA	Carrier Aggregation
CADS	Carrier Aggregation Deployment Scenarios
CC	Component Carriers
CHO	Conditional Handover
D2D	Device-To-Device
DAPS	Dual Active Protocol Stack
DC	Dual Connectivity
eMBB	Enhanced Mobile Broadband
FCL	Fuzzy Control
HCP	Handover Control Parameters
HetNets	Heterogeneous Networks
HFP	Handover Failure Probability
HOM	Handover Margin
HOP	Handover Probability
HPO	Handover Parameter Optimization
HPPP	Handover Ping-Pong Probability
IMT-Advanced	International Mobile Telecommunications Advanced
IP	Internet Protocol
IoT	Internet of Things
ITU	International Telecommunication Union
LBO	Load Balancing Optimization
LOS	Line-of-Sight
LTE-A	Long Term Evolution-Advanced
M2M	Machine-to-Machine
MAC	Medium Access Control
ML	Machine Learning
mm-waves	Millimeter Waves
mMTC	Massive Machine-Type Communications
NFV	Network Function Virtualization
PCC	Primary Component Carriers
PDCP	Packet Data Convergence Protocol
PHY	Physical
RLC	Radio Link Control
RLF	Radio Link Failure
RSSI	Received Signal Strength Indicator
SCC	Secondary Component Carriers
SDN	Software-Defined Network
SDNV	Software-Defined Network Virtualization
SON	Self-Optimization Network
TTT	Time-to-Trigger
UE	User Equipment
URC	Ultra-Reliable Communication
URLLC	Ultra-Reliable and Low Latency Communications
V2X	Vehicle-to-Everything
WiMAX	Worldwide Interoperability for Microwave Access
WLAN	Wireless Local Area Networks

REFERENCES

- [1] S. Li, L. Da Xu, and S. Zhao, "5G Internet of Things: A survey," *J. Ind. Inf. Integr.*, vol. 10, pp. 1–9, Jun. 2018.
- [2] P. P. Ray, "A survey on Internet of Things architectures," *J. King Saud Univ.-Comput. Inf. Sci.*, vol. 30, no. 3, pp. 291–319, 2018.
- [3] C. R. Srinivasan, B. Rajesh, P. Saikalyan, K. Premeasagar, and E. S. Yadav, "A review on the different types of Internet of Things (IoT)," *J. Adv. Res. Dyn. Control Syst.*, vol. 11, no. 1, pp. 154–158, 2019.
- [4] M. Avital, A. R. Dennis, M. Rossi, C. Sørensen, and A. French, "The transformative effect of the Internet of Things on business and society," *Commun. Assoc. for Inf. Syst.*, vol. 44, no. 1, pp. 129–140, 2019.
- [5] M. Presser, Q. Zhang, A. Bechmann, and M. J. Beliatas, "The Internet of Things as driver for digital business model innovation," in *Digital Business Models*. New York, NY, USA: Springer, 2019, pp. 27–55.
- [6] H. E. Yilmaz, A. Sirel, and M. F. Esen, "The impact of Internet of Things self-security on daily business and business continuity," in *Handbook of Research on Cloud Computing and Big Data Applications in IoT*. Hershey, PA, USA: IGI Global, 2019, pp. 481–498.
- [7] A. Raschendorfer, B. Mörzinger, E. Steinberger, P. Pelzmann, R. Oswald, M. Stadler, and F. Bleicher, "On IOTA as a potential enabler for an M2M economy in manufacturing," *Procedia CIRP*, vol. 79, pp. 379–384, 2019.
- [8] F. Schröder, "5G: New opportunities?" in *Future Telco*. New York, NY, USA: Springer, 2019, pp. 63–74.
- [9] D. Chandramouli, R. Liebhart, and J. Pirskanen, *5G for the Connected World*. Hoboken, NJ, USA: Wiley, 2019.
- [10] H. J. Patil and D. T. Patil, "Internet of Things & its application to the libraries," in *Proc. Int. Conf. Internet Things Current Trends Libraries (ITCTL)*. Mehsana, India: Gujarat Power Engineering and Research Institute, 2018, pp. 1–12.
- [11] G. Muralidhara and H. Faheem, "Huawei's quest for global markets," in *China-Focused Cases*. New York, NY, USA: Springer, 2019, pp. 65–80.
- [12] M. Paulo, "China-Europe investment cooperation: A digital silk road," in *The Belt & Road Initiative in the Global Arena*. New York, NY, USA: Springer, 2018, pp. 177–204.
- [13] K. David and H. Berndt, "6G vision and requirements: Is there any need for beyond 5G?" *IEEE Veh. Technol. Mag.*, vol. 13, no. 3, pp. 72–80, Sep. 2018.
- [14] F. Tariq, M. Khandaker, K.-K. Wong, M. Imran, M. Bennis, and M. Debbah, "A speculative study on 6G," 2019, *arXiv:1902.06700*. [Online]. Available: <http://arxiv.org/abs/1902.06700>
- [15] W. Saad, M. Bennis, and M. Chen, "A vision of 6G wireless systems: Applications, trends, technologies, and open research problems," 2019, *arXiv:1902.10265*. [Online]. Available: <http://arxiv.org/abs/1902.10265>
- [16] L. Dussopt and I. Velez, "Mm-wave small-cell access and backhauling for 5G," in *Mi-WAVES, E3 Net Work, Seventh Framework Program (CEA-LETI) and (CETI)*. Franch, 2014.
- [17] XoomTrainings. (Sep. 12, 2017). *How 5G Network Capabilities Will Transform the Way we Live*. [Online]. Available: <http://www.xoomtrainings.com/blog/how-5g-network-capabilities-will-transform-the-way-we-live>.
- [18] *Minimum Requirements Related to Technical Performance for IMT-2020 Radio Interface(s)*, document ITU-R M.2410-0, 2017.
- [19] A. R. Bahai, B. R. Saltzberg, and M. Ergen, "Ultra WideBand technologies," in *Multi-Carrier Digital Communications: Theory and Applications of OFDM*. New York, NY, USA: Springer, 2004, ch. 12, pp. 349–355.
- [20] Z. Pi and F. Khan, "An introduction to millimeter-wave mobile broadband systems," *IEEE Commun. Mag.*, vol. 49, no. 6, pp. 101–107, Jun. 2011.
- [21] T. S. Rappaport, S. Sun, R. Mayzus, H. Zhao, Y. Azar, K. Wang, G. N. Wong, J. K. Schulz, M. Samimi, and F. Gutierrez, "Millimeter wave mobile communications for 5G cellular: It will work!," *IEEE Access*, vol. 1, pp. 335–349, 2013.
- [22] ITU, *Emerging Trends in 5G/IMT2020*, document, International Telecommunication Union (ITU), Geneva, Switzerland, 2016.
- [23] GSMA, "5G spectrum public policy position," GSM Assoc., London, U.K., White Paper GSMA-5G-Spectrum-2016, Nov. 2016.
- [24] F. Gutierrez, S. Agarwal, K. Parrish, and T. S. Rappaport, "On-chip integrated antenna structures in CMOS for 60 GHz WPAN systems," *IEEE J. Sel. Areas Commun.*, vol. 27, no. 8, pp. 1367–1378, Oct. 2009.
- [25] H. M. Marzouk, M. I. Ahmed, and A.-E.-H. Shaalan, "Novel dual-band 28/38 GHz MIMO antennas for 5G mobile applications," *Prog. Electromagn. Res. C*, vol. 93, pp. 103–117, 2019.
- [26] W. Ahmad and W. T. Khan, "Small form factor dual band (28/38 GHz) PIFA antenna for 5G applications," in *Proc. IEEE MTT-S Int. Conf. Microw. Intell. Mobility (ICMIM)*, Mar. 2017, pp. 21–24.
- [27] Y. Rahayu and M. I. Hidayat, "Design of 28/38 GHz dual-band triangular-shaped slot microstrip antenna array for 5G applications," in *Proc. 2nd Int. Conf. Telematics Future Gener. Netw. (TAFGEN)*, Jul. 2018, pp. 93–97.
- [28] J.-J. Park, J. Liang, J. Lee, H.-K. Kwon, M.-D. Kim, and B. Park, "Millimeter-wave channel model parameters for urban microcellular environment based on 28 and 38 GHz measurements," in *Proc. IEEE 27th Annu. Int. Symp. Pers., Indoor, Mobile Radio Commun. (PIMRC)*, Sep. 2016, pp. 1–5.
- [29] F. Qamar, M. N. Hindia, K. Dimiyati, K. A. Noordin, M. B. Majed, T. Abd Rahman, and I. S. Amiri, "Investigation of future 5G-IoT millimeter-wave network performance at 38 GHz for urban microcell outdoor environment," *Electronics*, vol. 8, no. 5, p. 495, May 2019.
- [30] B. Yu, K. Yang, C.-Y.-D. Sim, and G. Yang, "A novel 28 GHz beam steering array for 5G mobile device with metallic casing application," *IEEE Trans. Antennas Propag.*, vol. 66, no. 1, pp. 462–466, Jan. 2018.
- [31] B. Xu, K. Zhao, Z. Ying, D. Sjöberg, W. He, and S. He, "Analysis of impacts of expected RF EMF exposure restrictions on peak EIRP of 5G user equipment at 28 GHz and 39 GHz bands," *IEEE Access*, vol. 7, pp. 20996–21005, 2019.
- [32] U. Kodak and G. M. Rebeiz, "A 5G 28-GHz common-leg T/R front-end in 45-nm CMOS SOI With 3.7-dB NF and -30-dBc EVM with 64-QAM/500-MBaud modulation," *IEEE Trans. Microw. Theory Techn.*, vol. 67, no. 1, pp. 318–331, Jan. 2019.
- [33] H. Zhang and L. Dai, "Mobility prediction: A survey on State-of-the-Art schemes and future applications," *IEEE Access*, vol. 7, pp. 802–822, 2019.
- [34] A. Stamou, N. Dimitriou, K. Kontovasilis, and S. Papavassiliou, "Autonomic handover management for heterogeneous networks in a future Internet context: A survey," *IEEE Commun. Surveys Tuts.*, vol. 21, no. 4, pp. 3274–3297, 4th Quart., 2019.
- [35] S. Reddy and S. Venkatarama, "A comprehensive survey on seamless mobility management in 5G communications," *Int. J. Future Gener. Commun. Netw.*, vol. 11, no. 6, pp. 33–48, 2018.
- [36] S. K. Das, "Mobility management—A personal perspective," *Comput. Commun.*, vol. 131, pp. 26–31, Oct. 2018.
- [37] A. A. R. Alsaedy and E. K. P. Chong, "A review of mobility management entity in LTE networks: Power consumption and signaling overhead," *Int. J. Netw. Manage.*, vol. 30, no. 1, p. e2088, Jan. 2020.
- [38] N. Akkari and N. Dimitriou, "Mobility management solutions for 5G networks: Architecture and services," *Comput. Netw.*, vol. 169, Mar. 2020, Art. no. 107082.
- [39] M. Lauridsen, L. C. Gimenez, I. Rodriguez, T. B. Sorensen, and P. Mogensen, "From LTE to 5G for connected mobility," *IEEE Commun. Mag.*, vol. 55, no. 3, pp. 156–162, Mar. 2017.
- [40] *Self-Organizing Networks (SON) Policy, Network Resource Model (NRM), Integration Reference Point (IRP); Information Service (IS) (Release 12)*, 3GPP, document TS 28.628 V12.1.0., 2014. [Online]. Available: <http://www.3gpp.org/DynaReport/28628.htm>
- [41] *Self-Organizing Networks (SON) Policy Network Resource Model (NRM) Integration Reference Point (IRP); Requirements (Release 12)*, 3GPP, document TS 28.627 V12.0.0., 2014. [Online]. Available: <http://www.3gpp.org/DynaReport/28627.htm>
- [42] *Self-Organizing Networks (SON) Policy Network Resource Model (NRM) Integration Reference Point (IRP); Requirements (Release 15)*, 3GPP, document TS 28.627 V15.0.0., 2018.
- [43] M. Ergen, "Method and system for routing delay-tolerant communication messages to a destination device," U.S. Patent 16516172, Jul. 18, 2020.
- [44] J. Li, D. Raychaudhuri, and R. Yates, "Unified handoff control protocol for dynamic path rerouting in mobile ATM networks," in *Proc. 9th IEEE Int. Symp. Pers., Indoor Mobile Radio Commun.*, Sep. 1998, pp. 323–329.
- [45] P. Mishra and M. Srivastava, "Effect of connection rerouting on application performance in mobile networks," *IEEE Trans. Comput.*, vol. 47, no. 4, pp. 371–390, Apr. 1998.
- [46] G. Yuan, X. Zhang, W. Wang, and Y. Yang, "Carrier aggregation for LTE-advanced mobile communication systems," *IEEE Commun. Mag.*, vol. 48, no. 2, pp. 88–93, Feb. 2010.

- [47] *Minimum Requirements Related to Technical Performance for IMT-2020 Radio Interface(s)*, document ITU-R M.2410-0, 2017.
- [48] K. I. Pedersen, J. Wigard, and P. Mogensen, "Method of performing handover by using different handover parameters for different traffic and user classes in a communication network," U.S. Patent 6993 332 B2, Jan. 31, 2006.
- [49] I. Shayea, M. Ismail, R. Nordin, M. Ergen, N. Ahmad, N. F. Abdullah, A. Alhammadi, and H. Mohamad, "New weight function for adapting handover margin level over contiguous carrier aggregation deployment scenarios in LTE-advanced system," *Wireless Pers. Commun.*, vol. 108, no. 2, pp. 1179–1199, Sep. 2019.
- [50] I. Shayea, M. Ismail, R. Nordin, H. Mohamad, T. Abd Rahman, and N. F. Abdullah, "Novel handover optimization with a coordinated contiguous carrier aggregation deployment scenario in LTE-advanced systems," *Mobile Inf. Syst.*, vol. 2016, Dec. 2016, Art. no. 4939872.
- [51] A. Alhammadi, M. Roslee, M. Y. Alias, I. Shayea, and A. Alquhali, "Velocity-aware handover self-optimization management for next generation networks," *Appl. Sci.*, vol. 10, no. 4, p. 1354, Feb. 2020.
- [52] M. Banagar, V. V. Chetlur, and H. S. Dhillon, "Handover probability in drone cellular networks," *IEEE Wireless Commun. Lett.*, vol. 9, no. 7, pp. 933–937, Jul. 2020.
- [53] A. Abdulraheem, R. Mardeni, A. M. Yusoff, S. Ibraheem, and A. Saddam, "Self-optimization of handover control parameters for mobility management in 4G/5G heterogeneous networks," *Autom. Control Comput. Sci.*, vol. 53, no. 5, pp. 441–451, Sep. 2019.
- [54] A. Alhammadi, M. Roslee, M. Y. Alias, I. Shayea, S. Alraih, and K. S. Mohamed, "Auto tuning self-optimization algorithm for mobility management in LTE-A and 5G HetNets," *IEEE Access*, vol. 8, pp. 294–304, 2020.
- [55] A. Alhammadi, M. Roslee, M. Y. Alias, I. Shayea, S. Alraih, and A. B. Abas, "Advanced handover self-optimization approach for 4G/5G HetNets using weighted fuzzy logic control," in *Proc. 15th Int. Conf. Telecommun. (ConTEL)*, Jul. 2019, pp. 1–6.
- [56] D. Castro-Hernandez and R. Paranjape, "Optimization of handover parameters for LTE/LTE-A in-building systems," *IEEE Trans. Veh. Technol.*, vol. 67, no. 6, pp. 5260–5273, Jun. 2018.
- [57] D. Lynch, M. Fenton, D. Fagan, S. Kucera, H. Claussen, and M. O'Neill, "Automated self-optimization in heterogeneous wireless communications networks," *IEEE/ACM Trans. Netw.*, vol. 27, no. 1, pp. 419–432, Feb. 2019.
- [58] M. T. Nguyen, S. Kwon, and H. Kim, "Mobility robustness optimization for handover failure reduction in LTE small-cell networks," *IEEE Trans. Veh. Technol.*, vol. 67, no. 5, pp. 4672–4676, May 2018.
- [59] P. Sapkale and U. Kolekar, "Handover decision algorithm for next generation," in *Proc. Int. Conf. Wireless Commun.*, 2020, pp. 269–277.
- [60] I. Shayea, M. Ismail, R. Nordin, and H. Mohamad, "Adaptive handover decision algorithm based on multi-influence factors through carrier aggregation implementation in LTE-advanced system," *J. Comput. Netw. Commun.*, vol. 2014, Nov. 2014, Art. no. 739504.
- [61] J. Winkler, C. P. J.-W. Kuklinski, and R. Moser, "Decision making in emerging markets: The delphi approach's contribution to coping with uncertainty and equivocality," *J. Bus. Res.*, vol. 68, no. 5, pp. 1118–1126, May 2015.
- [62] F. Zhu and J. McNair, "Multiservice vertical handoff decision algorithms," *EURASIP J. Wireless Commun. Netw.*, vol. 2006, no. 1, pp. 1–13, Dec. 2006.
- [63] M. S. Mollel, A. I. Abubakar, M. Ozturk, S. Kaijage, M. Kisangiri, A. Zoha, M. A. Imran, and Q. H. Abbasi, "Intelligent handover decision scheme using double deep reinforcement learning," *Phys. Commun.*, vol. 42, Oct. 2020, Art. no. 101133.
- [64] M. Peuster, H. Küttner, and H. Karl, "A flow handover protocol to support state migration in software-defined networks," *Int. J. Netw. Manage.*, vol. 29, no. 4, p. e2067, Jul. 2019.
- [65] J.-P. Vasseur, V. K. Kolar, and S. Pandey, "Dynamic rerouting of wireless traffic based on input from machine learning-based mobility path analysis," U.S. Patent 10375 565 B2, Aug. 6, 2019.
- [66] I. Shayea, T. Abd. Rahman, M. Hadri Azmi, and M. R. Islam, "Real measurement study for rain rate and rain attenuation conducted over 26 GHz microwave 5G link system in malaysia," *IEEE Access*, vol. 6, pp. 19044–19064, 2018.
- [67] I. Shayea, T. Abd. Rahman, M. Hadri Azmi, and A. Arsad, "Rain attenuation of millimetre wave above 10 GHz for terrestrial links in tropical regions," *Trans. Emerg. Telecommun. Technol.*, vol. 29, no. 8, p. e3450, Aug. 2018.
- [68] A. M. Al-Samman, T. A. Rahman, M. H. Azmi, and I. Shayea, "Path loss model and channel capacity for UWB-MIMO channel in outdoor environment," *Wireless Pers. Commun.*, vol. 107, pp. 271–281, Mar. 2019.
- [69] A. M. Al-Samman, T. A. Rahman, and R. Ngah, "UWB channel characterization in 28 GHz millimeter waveband for 5G cellular networks," *Jurnal Teknologi*, vol. 78, nos. 6–11, pp. 19–23, Jun. 2016.
- [70] S. Coleri, M. Ergen, A. Puri, and A. Bahai, "Channel estimation techniques based on pilot arrangement in OFDM systems," *IEEE Trans. Broadcast.*, vol. 48, no. 3, pp. 223–229, Sep. 2002.
- [71] E. Calvanese Strinati, S. Barbarossa, J. Luis Gonzalez-Jimenez, D. Kténas, N. Cassiau, and C. Dehos, "6G: The next frontier," 2019, *arXiv:1901.03239*. [Online]. Available: <http://arxiv.org/abs/1901.03239>
- [72] M. A. Esmail, A. M. Ragheb, H. A. Fathallah, M. Altamimi, and S. A. Alshebeili, "5G-28 GHz signal transmission over hybrid all-optical FSO/RF link in dusty weather conditions," *IEEE Access*, vol. 7, pp. 24404–24410, 2019.
- [73] I. Siomina, P. Varbrand, and D. Yuan, "Automated optimization of service coverage and base station antenna configuration in UMTS networks," *IEEE Wireless Commun.*, vol. 13, no. 6, pp. 16–25, Dec. 2006.
- [74] U. Varshney, "4G wireless networks," *IT Prof.*, vol. 14, no. 5, pp. 34–39, Sep./Oct. 2012.
- [75] A. Bou Saleh, S. Redana, J. Hämäläinen, and B. Raaf, "On the coverage extension and capacity enhancement of inband relay deployments in LTE-advanced networks," *J. Electr. Comput. Eng.*, vol. 2010, pp. 1–12, 2010.
- [76] Y. Yuan, Z. Zuo, Y. Guan, X. Chen, W. Luo, Q. Bi, P. Chen, and X. She, "LTE-advanced coverage enhancements," *IEEE Commun. Mag.*, vol. 52, no. 10, pp. 153–159, Oct. 2014.
- [77] A. Elnashar, "Coverage and capacity planning of 4G networks," in *Design, Deployment and Performance of 4G-LTE Networks: Practical Approach*, A. Hoboken, NJ, USA: Wiley, 2014, pp. 349–444.
- [78] G. Liu, X. Hou, Y. Huang, H. Shao, Y. Zheng, F. Wang, and Q. Wang, "Coverage enhancement and fundamental performance of 5G: Analysis and field trial," *IEEE Commun. Mag.*, vol. 57, no. 6, pp. 126–131, Jun. 2019.
- [79] E. Demarchou, C. Psomas, and I. Krikidis, "Mobility management in ultra-dense networks: Handover skipping techniques," *IEEE Access*, vol. 6, pp. 11921–11930, 2018.
- [80] B. Zhang, W. Qi, and J. Zhang, "An energy efficiency and ping-pong handover ratio optimization in two-tier heterogeneous networks," in *Proc. IEEE 8th Annu. Comput. Commun. Workshop Conf. (CCWC)*, Jan. 2018, pp. 532–536.
- [81] A. Alhammadi, M. Roslee, M. Y. Alias, I. Shayea, and S. Alraih, "Dynamic handover control parameters for LTE-A/5G mobile communications," in *Proc. Adv. Wireless Opt. Commun. (RTUWO)*, Nov. 2018, pp. 39–44.
- [82] P.-J. Hsieh, W.-S. Lin, K.-H. Lin, and H.-Y. Wei, "Dual-connectivity prevalent handover scheme in Control/User-plane split networks," *IEEE Trans. Veh. Technol.*, vol. 67, no. 4, pp. 3545–3560, Apr. 2018.
- [83] B. Yang, X. Yang, X. Ge, and Q. Li, "Coverage and handover analysis of ultra-dense millimeter-wave networks with control and user plane separation architecture," *IEEE Access*, vol. 6, pp. 54739–54750, 2018.
- [84] S. N. K. Marwat, S. Meyer, T. Weerawardane, and C. Goerg, "Congestion-aware handover in LTE systems for load balancing in transport network," *ETRI J.*, vol. 36, no. 5, pp. 761–771, 2014.
- [85] A. I. Saleh, M. S. Elkasas, and A. A. Hamza, "Ant colony prediction by using sectorized diurnal mobility model for handover management in PCS networks," *Wireless Netw.*, vol. 25, no. 2, pp. 765–775, Feb. 2019.
- [86] K. Vasudeva, M. Simsek, D. Lopez-Perez, and I. Guvenc, "Analysis of handover failures in heterogeneous networks with fading," *IEEE Trans. Veh. Technol.*, vol. 66, no. 7, pp. 6060–6074, Jul. 2017.
- [87] O. Semiari, W. Saad, M. Bennis, and B. Maham, "Caching meets millimeter wave communications for enhanced mobility management in 5G networks," *IEEE Trans. Wireless Commun.*, vol. 17, no. 2, pp. 779–793, Feb. 2018.
- [88] I. Shayea, M. Hadri Azmi, T. Abd. Rahman, M. Ergen, C. Tien Han, and A. Arsad, "Spectrum gap analysis with practical solutions for future mobile data traffic growth in malaysia," *IEEE Access*, vol. 7, pp. 24910–24933, 2019.

- [89] M. Ergen, P. Uberoy, T. Mak, and R. Jalil, "Method and apparatus for load balancing in a wireless communication network," U.S. Patent 8 849 275 B2, Sep. 30, 2014.
- [90] M. Hassanalian and A. Abdelkefi, "Classifications, applications, and design challenges of drones: A review," *Prog. Aerosp. Sci.*, vol. 91, pp. 99–131, May 2017.
- [91] J. C. Rosser, V. Vignesh, B. A. Terwilliger, and B. C. Parker, "Surgical and medical applications of drones: A comprehensive review," *JSLs: J. Soc. Laparoendoscopic Surgeons*, vol. 22, no. 3, 2018, Art. no. e2018.00018.
- [92] T. Rakha and A. Gorodetsky, "Review of unmanned aerial system (UAS) applications in the built environment: Towards automated building inspection procedures using drones," *Autom. Construct.*, vol. 93, pp. 252–264, Sep. 2018.
- [93] K. Bhatt, A. Pourmand, and N. Sikka, "Targeted applications of unmanned aerial vehicles (Drones) in telemedicine," *Telemed. e-Health*, vol. 24, no. 11, pp. 833–838, Nov. 2018.
- [94] X. Wang, S. Poikonen, and B. Golden, "The vehicle routing problem with drones: Several worst-case results," *Optim. Lett.*, vol. 11, no. 4, pp. 679–697, Apr. 2017.
- [95] Z. Guan and T. Kulkarni, "On the effects of mobility uncertainties on wireless communications between flying drones in the mmWave/THz bands," in *Proc. IEEE Conf. Comput. Commun. Workshops (INFOCOM WKSHPs)*, Apr. 2019, pp. 768–773.
- [96] R. Amorim, P. Mogensen, T. Sorensen, I. Z. Kovacs, and J. Wigard, "Pathloss measurements and modeling for UAVs connected to cellular networks," in *Proc. IEEE 85th Veh. Technol. Conf. (VTC Spring)*, Jun. 2017, pp. 1–6.
- [97] A. Jain, E. Lopez-Aguilera, and I. Demirkol, "Are mobility management solutions ready for 5G and beyond?" 2019, *arXiv:1902.02679*. [Online]. Available: <http://arxiv.org/abs/1902.02679>
- [98] C. Altay, A. V. Atli, S. Civanlar, and A. O. Ercan, "System and method for a vehicular network service over a 5G network," U.S. Patent App. 15 945 941, Apr. 5, 2019.
- [99] S. K. Biswash and D. N. K. Jayakody, "Performance based user-centric dynamic mode switching and mobility management scheme for 5G networks," *J. Netw. Comput. Appl.*, vol. 116, pp. 24–34, Aug. 2018.
- [100] M. Dalla Cia, F. Mason, D. Peron, F. Chiariotti, M. Polese, T. Mahmoodi, M. Zorzi, and A. Zanella, "Using smart city data in 5G self-organizing networks," *IEEE Internet Things J.*, vol. 5, no. 2, pp. 645–654, Apr. 2018.
- [101] M. Huang and X. Zhang, "Big data analysis on beam spectrum for handover optimization in massive-MIMO cellular systems," in *Proc. IEEE Wireless Commun. Netw. Conf. (WCNC)*, Apr. 2018, pp. 1–6.
- [102] S. Dobson, D. Hutchison, A. Mauthe, A. Schaeffer-Filho, P. Smith, and J. P. Sterbenz, "Self-organization and resilience for networked systems: Design principles and open research issues," *Proc. IEEE*, vol. 107, no. 4, pp. 819–834, Apr. 2019.
- [103] J. Wu and P. Fan, "A survey on high mobility wireless communications: Challenges, opportunities and solutions," *IEEE Access*, vol. 4, pp. 450–476, 2016.
- [104] R.-H. Liou, Y.-B. Lin, and S.-C. Tsai, "An investigation on LTE mobility management," *IEEE Trans. Mobile Comput.*, vol. 12, no. 1, pp. 166–176, Jan. 2013.
- [105] R. Bolla and M. Repetto, "A comprehensive tutorial for mobility management in data networks," *IEEE Commun. Surveys Tuts.*, vol. 16, no. 2, pp. 812–833, 2nd Quart., 2014.
- [106] *Self-Organizing Networks (SON) Policy, Network Resource Model (NRM), Integration Reference Point (IRP); Information Service (IS) (Release 15)*, 3GPP, document TS 28.628 V15.0.0, 2018.
- [107] A. Catovic, P. A. Agashe, R. Gupta, G. B. Horn, R. Prakash, and F. Ulupinar, "Adaptation of handover parameters," U.S. Patent 9 107 133 B2, Jul. 8, 2015.
- [108] H. Zhu and K.-S. Kwak, "Performance analysis of an adaptive handoff algorithm based on distance information," *Comput. Commun.*, vol. 30, no. 6, pp. 1278–1288, Mar. 2007.
- [109] P. Bhattacharya and P. Banerjee, "A new velocity dependent variable hysteresis-margin-based call handover scheme," *IJRSP*, vol. 35, no. 5, pp. 368–371, 2006.
- [110] P. Muñoz, R. Barco, and I. de la Bandera, "On the potential of handover parameter optimization for self-organizing networks," *IEEE Trans. Veh. Technol.*, vol. 62, no. 5, pp. 1895–1905, Jun. 2013.
- [111] B. Sas, K. Spaey, and C. Blondia, "A SON function for steering users in multi-layer LTE networks based on their mobility behaviour," in *Proc. IEEE 81st Veh. Technol. Conf. (VTC Spring)*, May 2015, pp. 1–7.
- [112] R. P. Ray and L. Tang, "Hysteresis margin and load balancing for handover in heterogeneous network," *Int. J. Future Comput. Commun.*, vol. 4, no. 4, p. 231, 2015.
- [113] S. Nie, D. Wu, M. Zhao, X. Gu, L. Zhang, and L. Lu, "An enhanced mobility state estimation based handover optimization algorithm in LTE–A self-organizing network," *Procedia Comput. Sci.*, vol. 52, pp. 270–277, 2015.
- [114] W. Zheng, H. Zhang, X. Chu, and X. Wen, "Mobility robustness optimization in self-organizing LTE femtocell networks," *EURASIP J. Wireless Commun. Netw.*, vol. 2013, no. 1, pp. 1–10, Dec. 2013.
- [115] M. I. B. lan, B. Sas, T. Jansen, I. Moerman, K. Spaey, and P. Demeester, "An enhanced weighted performance-based handover parameter optimization algorithm for LTE networks," *EURASIP J. Wireless Commun. Netw.*, vol. 2011, no. 1, p. 98, 2011.
- [116] K. Kitagawa, T. Komine, T. Yamamoto, and S. Konishi, "A handover optimization algorithm with mobility robustness for LTE systems," in *Proc. IEEE 22nd Int. Symp. Pers., Indoor Mobile Radio Commun.*, Sep. 2011, pp. 1647–1651.
- [117] L. Ewe and H. Bakker, "Base station distributed handover optimization in LTE self-organizing networks," in *Proc. IEEE 22nd Int. Symp. Pers., Indoor Mobile Radio Commun.*, Sep. 2011, pp. 243–247.
- [118] A. Awada, B. Wegmann, D. Rose, I. Vierung, and A. Klein, "Towards self-organizing mobility robustness optimization in inter-RAT scenario," in *Proc. IEEE 73rd Veh. Technol. Conf. (VTC Spring)*, May 2011, pp. 1–5.
- [119] P. Legg, G. Hui, and J. Johansson, "A simulation study of LTE intra-frequency handover performance," in *Proc. IEEE 72nd Veh. Technol. Conf. (Fall)*, Sep. 2010, pp. 1–5.
- [120] Y. Lee, B. Shin, J. Lim, and D. Hong, "Effects of time-to-trigger parameter on handover performance in SON-based LTE systems," in *Proc. 16th Asia-Pacific Conf. Commun. (APCC)*, Oct. 2010, pp. 492–496.
- [121] Q. Song, Z. Wen, X. Wang, L. Guo, and R. Yu, "Time-adaptive vertical handoff triggering methods for heterogeneous systems," in *Proc. Int. Workshop Adv. Parallel Process. Technol.*, 2009, pp. 302–312.
- [122] A. Schröder, H. Lundqvist, and G. Nunzi, "Distributed self-optimization of handover for the long term evolution," in *Proc. Int. Workshop Self-Organizing Syst.*, 2008, pp. 281–286.
- [123] *Self-Organizing Networks (SON) Policy Network Resource Model (NRM) Integration Reference Point (IRP); Information Service (IS) (Release 15)*, 3GPP, document TS 28.628 V15, 2019.
- [124] *Self-Organizing Networks (SON) Policy Network Resource Model (NRM) Integration Reference Point (IRP); Information Service (IS) (Release 15)*, 3GPP, document TS 28.628 V15, 2019.
- [125] A. Lobinger, S. Stefanski, T. Jansen, and I. Balan, "Coordinating handover parameter optimization and load balancing in LTE self-optimizing networks," in *Proc. IEEE 73rd Veh. Technol. Conf. (VTC Spring)*, May 2011, pp. 1–5.
- [126] P. Munoz, R. Barco, and S. Fortes, "Conflict resolution between load balancing and handover optimization in LTE networks," *IEEE Commun. Lett.*, vol. 18, no. 10, pp. 1795–1798, Oct. 2014.
- [127] N. Zia, S. S. Mwanje, and A. Mitschele-Thiel, "A policy based conflict resolution mechanism for MLB and MRO in LTE self-optimizing networks," in *Proc. IEEE Symp. Comput. Commun. (ISCC)*, Jun. 2014, pp. 1–6.
- [128] Y. Li, M. Li, B. Cao, and W. Liu, "A conflict avoid method between load balancing and mobility robustness optimization in LTE," in *Proc. 1st IEEE Int. Conf. Commun. China (ICCC)*, Aug. 2012, pp. 143–148.
- [129] S. Chen and J. Zhao, "The requirements, challenges, and technologies for 5G of terrestrial mobile telecommunication," *IEEE Commun. Mag.*, vol. 52, no. 5, pp. 36–43, May 2014.
- [130] E. Dahlman, G. Mildh, S. Parkvall, J. Peisa, J. Sachs, Y. Selén, and J. Sköld, "5G wireless access: Requirements and realization," *IEEE Commun. Mag.*, vol. 52, no. 12, pp. 42–47, 2014.
- [131] D. Jiang and G. Liu, "An overview of 5G requirements," in *5G Mobile Communications*. Springer, 2017, pp. 3–26.
- [132] *Self-Configuring and Self-Optimizing Network (SON) Use Cases and Solutions (Release 9)*, 3GPP, document TR 36.902 V9.3.1, 2011.
- [133] *Further Advancements for E-UTRA (LTE-Advanced) (Release 15)*, 3GPP, document TR 36.912 V15.0.0, 2018.
- [134] *Self-Organizing Networks (SON); Concepts and requirements (Release 15)*, 3GPP, document TS 32.500 V15.0.0, 2018.

- [135] *Telecommunication Management; Self-Organizing Networks (SON) Policy Network Resource Model (NRM) Integration Reference Point (IRP); Requirements (Release 11)*, 3GPP, document TS 32.521 V11.1.0, 2012.
- [136] *Telecommunication management; Self-Organizing Networks (SON) Policy Network Resource Model (NRM) Integration Reference Point (IRP); Information Service (IS) (Release 11)*, 3GPP, document TS 32.522 V11.7.0, 2013.
- [137] C.-H. Lee, S.-H. Lee, K.-C. Go, S.-M. Oh, J. S. Shin, and J.-H. Kim, "Mobile small cells for further enhanced 5G heterogeneous networks," *ETRI J.*, vol. 37, no. 5, pp. 856–866, Oct. 2015.
- [138] Y. Ouyang, Z. Li, L. Su, W. Lu, and Z. Lin, "Application behaviors driven self-organizing network (SON) for 4G LTE networks," *IEEE Trans. Netw. Sci. Eng.*, vol. 7, no. 1, pp. 3–14, Jan./Mar. 2020, doi: 10.1109/TNSE.2018.2877353.
- [139] *Release 16*, 3GPP, 2018. [Online]. Available: <http://www.3gpp.org/release-16>
- [140] Y. Tan and J. Yang, "Analytics-assisted, multi-agents, self-learning, self-managing, flexible and adaptive framework for intelligent SON," U.S. Patent 14 994 942, Jan. 13, 2019.
- [141] *Self-Configuring and Self-Optimizing Network (SON) Use Cases and Solutions (Release 9)*, 3GPP, document TR 36.902, 2011.
- [142] 3GPP, *Technical Specification Group Radio Access Network; NR and NG-RAN Overall Description; Stage 2(Release 16)*, document 3GPP TS 38.300 V16.1.0, 3GPP, France, 2020.
- [143] M. Inc, *Discussions on Conditional Handover Procedures, R2-1900143, R2-1900143*, 3GPP, Franch, 2019.
- [144] Ericsson, *Conditional Handover, R2-1710850, R2-1710850*, 3GPP, Franch, 2017.
- [145] *Conditional Handover in NR, R2-1900404, R2-1900404*, Ericsson, Stockholm, U.K., Franch, 2019.
- [146] Ericsson, *Conditional Handover, R2-1710850, R2-1710850*, 3GPP, Franch, 2017.
- [147] M. Inc, *Signalling Overhead Reduction for Conditional Handover, R2-1900144, R2-1900144*, 3GPP, Franch, 2019.
- [148] *Open issues of Conditional Handover, R2-1900275, R2-1900275*, CATT, Franch, 2019.
- [149] C. G. P. Oscar Ohlsson; Pontus Wallentin, *Reducing Mobility Interruption Time in 5G Networks*, Ericsson, Stockholm, U.K., 2020.
- [150] L. Tuyisenge, M. Ayaida, S. Tohme, and L.-E. Afilal, "Handover mechanisms in Internet of vehicles (IoV): Survey, trends, challenges, and issues," in *Global Advancements in Connected and Intelligent Mobility: Emerging Research and Opportunities*. Hershey, PA, USA: IGI Global, 2020, pp. 1–64.
- [151] I. Shayea, M. Ismail, R. Nordin, and H. Mohamad, "Handover performance over a coordinated contiguous carrier aggregation deployment scenario in the LTE-advanced system," *Int. J. Veh. Technol.*, vol. 2014, pp. 1–15, 2014.
- [152] M. Ergen, "What is artificial intelligence? Technical considerations and future perception," *Anatolian J. Cardiol.*, vol. 22, no. 2, pp. 5–7, 2019.
- [153] A. M. Aibinu, A. J. Onumanyi, A. P. Adedigba, M. Ipinyomi, T. A. Folorunso, and M. J. E. Salami, "Development of hybrid artificial intelligent based handover decision algorithm," *Eng. Sci. Technol., Int. J.*, vol. 20, no. 2, pp. 381–390, Apr. 2017.
- [154] J. V. C. Bazán, C. Rasgado, S. L. Salas, F. G. Lamont, and J. C. Bueno, "Artificial intelligence techniques in handover decision: A brief re-view," *Revista Ingeniantes*, vol. 6, no. 1, p. 1, 2019.
- [155] B. Shubyn, N. Lutsiv, O. Syrotynskyi, and R. Kolodii, "Deep learning based adaptive handover optimization for ultra-dense 5G mobile networks," in *Proc. IEEE 15th Int. Conf. Adv. Trends Radioelectron., Telecommun. Comput. Eng. (TCSET)*, Feb. 2020, pp. 869–872.
- [156] L. Yan, H. Ding, L. Zhang, J. Liu, X. Fang, Y. Fang, M. Xiao, and X. Huang, "Machine learning-based handovers for Sub-6 GHz and mmWave integrated vehicular networks," *IEEE Trans. Wireless Commun.*, vol. 18, no. 10, pp. 4873–4885, Oct. 2019.
- [157] H. Bello, Z. Xiaoping, R. Nordin, and J. Xin, "Advances and opportunities in passive wake-up radios with wireless energy harvesting for the Internet of Things applications," *Sensors*, vol. 19, no. 14, p. 3078, Jul. 2019.
- [158] A. Zahedi, M. Ergen, and I. Shayea, "Optimum time/power fraction of energy harvesting in TSR/PSR SWIPT-based cooperative communications with effective capacity maximization approach," *AEU-Int. J. Electron. Commun.*, vol. 111, Nov. 2019, Art. no. 152889.
- [159] M. Tawalbeh, A. Eardley, and L. Tawalbeh, "Studying the energy consumption in mobile devices," *Procedia Comput. Sci.*, vol. 94, pp. 183–189, 2016.
- [160] B. Munir and V. Dyo, "On the impact of mobility on battery-less RF energy harvesting system performance," *Sensors*, vol. 18, no. 11, p. 3597, Oct. 2018.



IBRAHEEM SHAYEA received the B.Sc. degree in electronic engineering from the University of Diyala, Iraq, in 2004, and the M.Sc. degree in computer and communication engineering and the Ph.D. degree in mobile communication engineering from the Universiti Kebangsaan Malaysia (UKM), Kuala Lumpur, Malaysia, in 2010 and 2015, respectively. He was a Postdoctoral Research Fellow with Istanbul Technical University, Turkey. He was also with the Wireless Communication Centre (WCC), UTM. He is currently an Associate Researcher of electrical engineering with Istanbul Technical University. He has published several papers related to wireless communication in the national/international journal and conferences. His research interests include mobility management, handover, LTE/LTE-A, carrier aggregation, radio propagation, indoors and outdoors wireless communication, the IoT, 5G, and 6G.



MUSTAFA ERGEN received the B.S. degree in electrical engineering as valedictorian from ODTU, and the M.A. degree in international studies, the M.O.T. degree from the HAAS Business School, and the M.S. and Ph.D. degrees in electrical engineering from the University of California Berkeley. He was a National Semiconductor Fellow (TI) with the University of California Berkeley, where he co-founded the Distributed Sensing Laboratory, focusing on statistical sensor intelligence and vehicular communication. He has Co-Founded Silicon Valley Startup WiChorus Inc., focusing on 4G technologies and acquired by Tellabs (Coriant). He is currently a Professor with Istanbul Technical University. He is also a Founder with Venture Funded Ambeent Inc., focusing on 5G wifi and AI. He holds more than 40 patent applications. He has many publications and authored three books, such as *Mobile Broadband, Multi-Carrier Digital Communications* in wireless communications (Springer), and *Girişimci Kapital: Silikon Vadisi Tarihi ve Startup Ekonomisi* (Alfa).



MARWAN HADRI AZMI received the B.Eng. (Hons.) degree in electrical and telecommunications from the Universiti Teknologi Malaysia, in 2003, the M.Sc. degree in communications and signal processing from the Imperial College of Science, Technology and Medicine, University of London, in 2005, and the Ph.D. degree from the University of New South Wales, Australia, in 2012. From 2012 to 2014, he was with McGill University (he spent his sabbatical leave), Canada, working with the funded projects by RIM Inc., and NSERC, Cooperative Spectrum Sensing and Information Relaying in Cognitive Wireless Communications. He is currently a Senior Lecturer with the Wireless Communication Centre, Universiti Teknologi Malaysia. His research interests include mobile and wireless communications, communication theory, error control coding, relay networks, spectrum sensing for cognitive radio, and iterative receiver.



SULTAN ALDIRMAZ ÇOLAK received the B.S. degree in electronics and communications engineering from Kocaeli University, Kocaeli, Turkey, in 2004, and the M.S. and Ph.D. degrees from Yildiz Technical University (YTU), Istanbul, in 2006 and 2012, respectively. She was a Visiting Research Scholar with the Department of Electrical and Computer Engineering, University of South Florida, in Spring and Summer 2009. She is currently an Assistant Professor with the Electronics and Communications Engineering Department, Kocaeli University. Her primary research interests include 5G systems, heterogeneous networks, MIMO systems, index modulation, and visible light communications.



ROSDIADEE NORDIN received the B.Eng. degree in electrical, electronic and systems engineering from the Universiti Kebangsaan Malaysia, in 2001, and the Ph.D. degree in wireless engineering under the supervision of Prof. J. McGeehan (The Godfather of mobile communications, U.K.) from the University of Bristol, U.K., in 2010. He was an Engineer with Malaysia's Telecommunication Industry for a period of five years. He has research experience with other international research institutes, such as the University of Bristol, the International Centre for Theoretical Physics, Italy, and the Wireless Research Centre, University of Canterbury, New Zealand. He is currently an Associate Professor of electrical, electronic and systems engineering with the Universiti Kebangsaan Malaysia. He is also a Professional Engineer by practice. He aims to connect everything wirelessly from human to remote objects you can imagine. He serves as the Vice-Chair for the Young Scientists Network (YSN), Academy of Sciences Malaysia (ASM).



YOUSEF IBRAHIM DARADKEH received the Doctor of Engineering Sciences (Ph.D. and P.Eng.) degrees in computer engineering and information technology (computer systems engineering and computer software engineering). He was a dynamic academician having more than 15 years of experience in teaching and scientific research development and administration experience. He was a Postdoctoral Research Fellow with the Department of Electrical and Computer Engineering, University of Calgary, Canada. He has taught wide spectrum of computer science, computer engineering and networks, and computer software engineering courses (undergraduate and graduate degrees). He has an excellent experience in designing courses that bridge the gap between academia and industry and follow the accreditation requirements. He is currently an Associate Professor with the Department of Computer Engineering and Networks, College of Engineering at Wadi Addawasir, Prince Sattam Bin Abdulaziz University, Saudi Arabia. He is a Senior Scientific Researcher and the Assistant Dean for the Administrative Affairs. He is also a well-known and respected scientist internationally. He has published over 90 high-quality refereed research papers in the international journal and conferences. He has also published two books, one Chapter, and Edited Book in the most prestigious publications. His international recognition of scientific achievements is demonstrated by numerous invitations to participate with the program committees of the international conferences and foreign journals and lecturing with renowned scientific centers around the world. He has a membership of the International Academy of Science and Engineering for Development (IASSED).

• • •