

Lawrence Berkeley National Laboratory

Recent Work

Title

THE KINETICS OF THE TRACE-ELEMENT CHROMIUM (III) IN THE HUMAN BODY

Permalink

<https://escholarship.org/uc/item/5d1412q4>

Author

Lim, Tek Hian.

Publication Date

1977-03-22

DISCLAIMER

This document was prepared as an account of work sponsored by the United States Government. While this document is believed to contain correct information, neither the United States Government nor any agency thereof, nor the Regents of the University of California, nor any of their employees, makes any warranty, express or implied, or assumes any legal responsibility for the accuracy, completeness, or usefulness of any information, apparatus, product, or process disclosed, or represents that its use would not infringe privately owned rights. Reference herein to any specific commercial product, process, or service by its trade name, trademark, manufacturer, or otherwise, does not necessarily constitute or imply its endorsement, recommendation, or favoring by the United States Government or any agency thereof, or the Regents of the University of California. The views and opinions of authors expressed herein do not necessarily state or reflect those of the United States Government or any agency thereof or the Regents of the University of California.

0 0 0 0 4 6 0 6 5 7 9

THE KINETICS OF THE TRACE-ELEMENT
CHROMIUM (III) IN THE HUMAN BODY

by

Tek Hian Lim

Lawrence Berkeley Laboratory
University of California
Berkeley, California 94720

This work was done with support from the U.S.
Energy Research and Development Administration.

THE KINETICS OF THE TRACE-ELEMENT CHROMIUM(III)
IN THE HUMAN BODY

Doctor of
Philosophy

Tek Hian Lim

Biophysics

ABSTRACT

This work involved kinetic studies of the trace-element chromium(III) in humans. The proposed model was derived from analysis of digital data acquired by a scintigraphic data analyzer from a whole body gamma-ray scintillation scanner, and from whole-body counts and plasma clearance data. These analyses were performed in vivo after intravenous administration of $^{51}\text{CrCl}_3$ to normal subjects and to patients suffering from hemochromatosis.

Rate-constants were calculated by fitting directly experimental data to the proposed kinetic model. Results showed that a linear relation exists between chromium(III) absorbing organs and the blood plasma chromium(III) compartment.

Rapid and slow uptake as well as clearance of chromium (III) were detected, primarily in the liver, spleen, adipose and muscle tissues and some in bone. Approximately 30% of the injected whole body radiochromium(III) was cleared within one day, and approximately 80% of the plasma radiochromium(III) was cleared within the same period.

It was found that blood plasma radiochromium(III) clearance

was faster in patients suffering from hemochromatosis compared to normal subjects; furthermore, a higher percentage of unbound radiochromium(III) in the plasma was found in hemochromatosis. A metabolic relationship between the two phenomena is suspected.

A whole-body clearance component with a long half-life of approximately 10 months suggests that chromium(III) is stored in some organ of the body, probably primarily in the liver. The whole-body scans showed the greatest concentration of radiochromium(III) to be in the liver.

At the present time, as far as we know, the chromium (III) kinetic model, presented in this work, is the first model of chromium(III) metabolism of any form to be proposed, and it is based on in vivo metabolism of a metabolically unperturbed human system.

Some researchers have reported that chromium(III) is important for glucose metabolism in humans. In this context, hopefully in the future, the model will be useful in assessing nutritional requirements of chromium(III) in the human diet, and its importance in disease processes such as diabetes.

ACKNOWLEDGEMENTS

I would like to express my deepest gratitude to Dr. Thornton Sargent III for his valuable guidance and continuous support during the progress of this study. I am also very grateful to Professor Alexander Nichols for his guidance and advice. Special thanks go to Professor Herbert Landahl for his help and valuable advice in computing methods and computer programming.

My sincere appreciation is extended to Professor Cornelius Tobias and Drs. Roger Wallace and James McRae, whose suggestions made me interested in the application of nuclear science and technology for biomedical research.

Also, I would like to thank all the institutions involved: the TRIGA III Reactor Laboratory, Department of Nuclear Engineering, University of California, Berkeley, the Donner Laboratory, Lawrence Berkeley Laboratory, the Computer Center of the Department of Biochemistry and Biophysics, University of California, San Francisco, and Alta Bates Hospital, for the use of facilities to do this work.

I am grateful to Professors Stanley Prussin and Thomas Budinger and Drs. Chris Cann, Fathi Nuh, Frank Lindgren, Edward Minougin and John Lindfoot for their expert advice.

Special thanks go to Dr. Henry Stauffer, who served as our physician in charge, as well as to Natalia Kusubov,

Sandra Bristol, Elaine Gong, Jeanette Nakagawa, Tina Catena, Pat Garbutt, Katherine Allan, Carol Bohlen and Dorothy Headquist for their excellent technical support.

The special help received from Irene Stadelhofer in the preparation and excellent typing of this dissertation as well as for her continuous interest concerning this study, is greatly appreciated. Also, I am thankful to Bob Stevens for the excellent drawings.

To all the volunteers, without whose help this study could have never been completed, my special appreciation.

Finally, I would like to thank my wife, Laurette, and my children Patricia, Dillana and Roger for their understanding, patience and support.

This work is dedicated to my late parents, Mr. and Mrs. D. K. Lim.

The opportunity given to me to do graduate work by the Department of Nuclear Engineering, University of California, Berkeley, under the University of California employee development program is acknowledged. This work was partly supported by the Energy Research and Development Administration.

TABLE OF CONTENTS

Chapter I. Introduction	1
1. Background and goal of present research	1
2. Present status of biological function of chromium(III) in humans and animals	3
A. Chromium in soil, water, plants, animal and man	3
B. Reaction of chromium with biological materials <u>in vitro</u>	4
C. Chromium deficiency in experimental animal	7
D. Site of action of chromium(III)	10
E. Role of chromium(III) in human nutrition	13
Chapter II. Experimental methods and results	16
1. Serum chromium determination	16
A. Method of analysis	16
B. Sample preparation and neutron irradiation	18
C. Gamma-ray analysis	19
D. Results	19
2. Serum chromium as a function of blood glucose and plasma insulin levels	20
3. Serum radiochromium(III) clearance	22
4. Serum radiochromium(III) response and glucose tolerance test	30
5. Radiochromium(III) localization, whole-body scanning and whole-body counting	30
A. Liver chromium(III)	34

B. Adipose and muscle tissue chromium(III)	42
C. Spleen chromium(III)	42
D. Bone	42
E. Other organs	45
F. Whole-body chromium(III)	45
6. Data analysis	47
A. Serum radiochromium	47
B. Localization of radiochromium(III)	48
Chapter III. Chromium(III) compartment model and kinetics	51
1. Schematics of proposed pathway	51
2. Proposed physiological compartment model	51
3. Mathematical model and computing method	54
A. Mathematical model	54
B. Computing methods	57
C. The FOCAL program MAMC5C	64
D. The modified MAMC5C program or the FOCAL program MMC5CII	66
4. Summary and discussion	68
References	85
Appendix A. The FOCAL Program MMC5CII	91
Appendix B. Clinical Laboratory Tests Data	106

I. Introduction

I. 1. Background and goal of present research

Chromium deficiency was not recognized until 1959 when chromium(III) was identified as the active component of a dietary ingredient required for optimal glucose utilization in rats¹.

The earliest detectable and most prominent feature of chromium(III) deficiency in rats and other experimental animals is an impairment of glucose tolerance. A more severe degree of chromium(III) deficiency leads to a syndrome indistinguishable from mild diabetes mellitus, including glycosuria and fasting hyperglycemia².

It has been shown^{3,4} that chromium(III) by itself does not influence glucose uptake in adipose and muscle tissue but by its presence, it makes insulin more effective in facilitating the transport of glucose across the cell membrane. Chromium(III) acts only when insulin is also present.

Recently, there has been increasing interest in the implication of these findings to human nutrition, and several reports suggest^{5,6} that chromium(III) is a nutritional requirement for man.

Results of a number of therapeutic trials of dietary supplementation with physiological quantities of chromium(III) to patients with impaired glucose tolerance including mature onset and chemical diabetics, exhibited improvement in an average of four out of ten patients⁷.

At the present time, fundamental knowledge concerning the "biological function" of chromium(III) and its critical nutritional level is still in an early stage. However, with the use of tracer techniques a considerable amount of knowledge of the fate and distribution of chromium(III) can be gathered. It is the purpose of this study to apply tracer methods in human subjects and to establish an acceptable chromium compartment model, the solution of which might lead to important information concerning biological function of chromium(III).

The experiments are divided in 5 categories as follow:

- Blood serum chromium level determination (in vitro)
- Blood serum radiochromium(III) clearance (in vivo)
- Radiochromium(III) localization in the body (in vivo)
- Whole-body radiochromium(III) retention (in vivo)
- Modeling and computer analysis

I. 2. Present status of biological function of chromium(III) in humans and animals

Information contributing to our knowledge of possible biological functions of the trace element chromium(III) falls in five categories which, individually or together, may help define the nutritional and physiological significance of the given element⁸.

A. Chromium in soil, water, plants, animal and man^{3,5,8,9}.

- a. Soil chromium levels depend on geographical locations; it is mostly in the form of Cr_2O_3 .
- b. Water chromium levels are less than 1 ppb; sea water has less chromium than river water; it also depends on geographical locations; and it occurs mostly in chromium(III) form.
- c. Plant chromium levels depend on geographical soil chromium concentration, the amount of fertilizer etc. The normal levels vary from 10 to 1000 $\mu\text{g}/\text{kg}$ plant on a dry basis, e. g., 390 ppb in potatoes and 590 ppb in hay.
- d. Chromium levels in animals, including mammals, range from 20 to several hundred ppb in most mammalian tissue, more concentrated in some tissues such as brain and central nervous system. In some tissues of some sea animals

(clam, crab) it can be up to 100 ppm. Chromium in the human body decreases with age, except in the lungs. Also, body chromium level depends very much on geographical location and diet.*

B. Reaction of chromium with biological materials
in vitro

- a. In chromium tanning of skin^{5,10}, the interaction of chromium(III) with protein probably involves complex formation between polynuclear chromium(III) species and the carboxyl groups of the protein.
- b. Selective affinity of chromium(III) to transferrin in blood plasma and of chromium(VI) to red blood cells was found in vitro as well as in vivo¹¹.
- c. In a succinate cytochrome dehydrogenase system, addition of ppm of chromium(III), stimulated the enzyme activity twice as much as did an equal amount of aluminum^{4,12}.
- d. Phosphoglucomutase, which requires magnesium and a second metal, responded to chromium(III) as a second metal with higher activity than Al, Pb, Fe etc.; in the absence of magnesium

*Present findings concerning chromium(III) levels in human blood plasma ranges from 2 to 20 ppb (p.21), and levels in other organs probably also have to be revised downward.

only chromium(III) increased enzyme activity^{5,13}.

- e. Rat liver responded to chromium(III) in vitro and in vivo with an increase of fatty acid and synthesis of cholesterol from acetate^{5,14}.
- f. Chromium(III) has been reported as a constituent of proteolytic enzymes, essential for their function; the activity of trypsin, inactivated by dialysis, was reconstituted by addition of chromium(III)^{5,15}.
- g. Stimulation of growth and biotin synthesis by chromium(III) in *Aerobacter Acrogenes* (bacteria) was observed^{5,16}.
- h. Nanogram quantities of chromium(III) are required for the optimal effect of insulin in every insulin-dependent system that has been investigated^{4,5,8}, and an uncorrected deficiency of chromium necessitates the addition of unphysiologically large concentrations of insulin to the media to achieve a normal response. In the presence of insulin, addition of chromium(III) to rat epididymal tissue of chromium deficient animal results in increase of^{4,17}:
 - 1) the rate of glucose uptake
 - 2) the oxidation of glucose to CO₂

- 3) the incorporation of glucose carbon into fat. The rate of incorporation of acetate into fat which is not insulin-dependent, is unchanged.
- i. The intracellular sites of action of insulin and probably also chromium were reported as follows:
 - 1) ribosome, where chromium(III) probably facilitates the insulin-stimulated incorporation of amino acids into protein¹⁸.
 - 2) mitochondria, where insulin stimulated swelling of mitochondria from chromium-deficient tissues is enhanced by the addition of chromium(III)¹⁹. Polarographic studies have indicated that chromium(III) initiates the formation of disulfide linkages between the intrachain disulfide of insulin and sulfhydryl groups of the mitochondrial membrane by participating in a ternary complex. This is believed to be the first step by which insulin increases the flux of glucose through the membrane²⁰.
 - j. At the present time it is not possible to postulate a special role of chromium related to the function of DNA and RNA, since chromium has not been studied yet in the field

of DNA and RNA metabolism. However some researchers^{5,21,22} reported the following:

1) extremely high concentration of chromium (III) was found in nucleoprotein (up to 10 times higher than in either nucleic acid or protein).

2) outstanding in chromium-nucleic acid bond stability was also reported.

k. Stimulation of fermentation of yeast by chromates [chromium(VI)] in quite high concentration (125-200 ppm) had been reported 80 years ago⁵.

C. Chromium deficiency in experimental animals

A low-chromium state can be described if an impairment of some function can be prevented or cured by physiological amounts of this element. The present known methods to measure chromium in different tissue can determine only the total chromium concentration; these analysis do not always give biologically meaningful results since these levels do not provide a valid index yet of chromium nutritional status. Chromium(III) reacts differently compared to chromium(VI), in vivo as well as in vitro. Simple chromium analysis does not tell what its chemical form is. For these reasons interpretation of the measured chromium levels in different organs is still not

straightforward.

a. Glucose tolerance

Many simple chromium compounds and synthetic organic complexes, with the exception of highly stable complexes, exhibit biological activity of similar magnitude. However, the biological effect achieved with any of these is not optimal and specifically it is not of the same magnitude as that achieved with "glucose tolerance factor" (GTF) chromium¹. GTF is an organic low molecular weight, dialyzable, naturally occurring chromium(III)-containing compound. The existence of such a factor had been suspected on the basis of observations that brewers yeast and some of its chemical fractions prevented the impairment of intravenous glucose tolerance developing in rats on Torula yeast diet, which was found to be deficient in chromium. Trivalent chromium as chromium acetate, added at 10 ppm to the drinking water, improved the impaired glucose tolerance in five out of five monkeys 23,24.

b. Chromium-insulin

The influence of chromium(III) on glucose tolerance is closely tied to the action of insulin⁵. When rats raised on a low chromium diet were subcutaneously injected with

10 mU of insulin/100g of body weight after 18 hours of fasting, their hypoglycemic response was significantly less than that of chromium-supplemented controls. Similarly, incorporation of glucose carbon into tissue glycogen 1 hour after injection of 1 mU of insulin/100g of body weight was much greater in chromium(III)-supplemented rats than in their deficient controls. Chromium(III) supplemented rats also maintained a higher glycogen concentration in their tissue after 18 hours of fasting than did low-chromium controls.

c. Syndrome simulating diabetes melitus

Fasting hyperglycemia and glycosuria did exist in rats raised under maximal exclusion of chromium contamination. Thus a diabetes-like syndrome has been observed in chromium-deficient rats².

d. Protein metabolism

When rats are raised on a low-chromium diet and are kept in plastic cages, chromium(III) supplementation in the drinking water (2ppm) results in a mild stimulation of growth, as compared with unsupplemented controls. The increased body weight is not due to water retention or fat deposit, but reflects a proportional increase

of tissue protein^{5,27}.

D. Site of action of chromium(III)

Since glucose tolerance is a complex function regulated by many diverse factors, the in vivo experiments did not offer specific information as to the site or mode of action of chromium(III) in the organism. Subsequently, it was attempted to define the site(s) by the use of various in vitro experiments with chromium-deficient, epididymal adipose, muscle and other tissues or sub-cellular fractions.

a. Epididymal adipose tissue

The fact that glucose uptake and the utilization of glucose for two different pathways, incorporation of glucose carbon into lipids and into CO₂, are affected by chromium(III) in approximately the same magnitude, and the ineffectiveness of the element in the absence of insulin, suggest that the site of action of chromium(III) is near the site of action of insulin, close to the first step of glucose metabolism^{4,17}.

The observed effect of chromium on cell entry of glucose, established the fact that the insulin-responsive cell membrane is one site of action of chromium(III)¹⁷. Even though an action at this site can account

for many effects of chromium, and insulin as well, on glucose metabolism, it has become evident that both chromium(III) and insulin must have additional sites of action, probably intracellular.

The mode of interaction between these two agents is not clear, but interaction of GTF with insulin has been suggested by Evans, et al²⁸; he believes that the α and ϵ amino groups of insulin are involved in the binding of GTF to insulin. Schwartz, on the other hand, considers this to be merely speculative.*

At least five biochemical possibilities of chromium(III) interaction with insulin have been suggested by Mertz^{5,29,30}.

- 1) Chromium(III) may form a complex with insulin in the pancreas or in the blood. The element could serve to maintain the polypeptide chains in an optimal tertiary configuration.
- 2) A possible role of chromium(III) as an inhibitor of tissue insulinase.
- 3) Chromium(III) could serve to increase the initial binding of insulin to tissue.
- 4) Chromium(III) could act as cofactor of a

*Personal communication.

membrane-carrier structure involved in glucose transport.

- 5) Chromium(III) could act as a catalyst in the initial reaction between insulin and specific membrane receptor sites.

b. Mitochondria

When it was shown that water uptake by isolated liver mitochondria was significantly increased by the addition of insulin together with certain sulfhydryl compounds, a system of sub-cellular, insulin-sensitive membranes became available as another model to study the action of chromium. Insulin-stimulated swelling of mitochondria from chromium-deficient tissues is enhanced by the addition of chromium(III)¹⁹.

c. Muscle

The effect of chromium(III) on glucose metabolism in muscle tissue has not been as extensively studied as in fat tissue. The main physiological action of insulin in muscle tissue may be the regulation of an intracellular process, protein synthesis, in which chromium(III) has been shown to play a role. Ribosomes are the suspected site of action⁵.

d. Crystalline Lens

The mechanism of action of insulin on the lens is not known, but it clearly adds an example of insulin-chromium(III) interaction. It was demonstrated that consistent insulin effects on glucose metabolism can be obtained with rat lens if the donor animals are sufficiently supplemented with chromium(III)^{31,32}.

E. Role of chromium(III) in human nutrition^{3,5,6,33,34,35,36,37,38,39}

The question whether low-chromium states exist in man is of considerable theoretical and practical interest. There are a number of syndromes related to impaired glucose metabolism with unknown etiology. The most common one is the gradual decline of glucose tolerance with increasing age which has been observed in samples of the United States population. Another example is maturity-onset diabetes which is not caused by lack of insulin, but has been attributed by different investigators to widely varying causes; one of these causes is chromium deficiency. A severe impairment of glucose metabolism in protein malnutrition in many areas is also well known, and a high incidence of abnormal glucose-tolerance tests in obesity and arteriosclerosis has been described.

The following were some reported clinical results:

- a. Significant improvement in glucose tolerance of four out of six maturity onset diabetics was observed following the daily administration of 180 to 1,000 μg chromium as $\text{CrCl}_3 \cdot 6\text{H}_2\text{O}$ for periods of 7 to 13 weeks under strictly controlled conditions. Shorter periods of chromium supplementation did not improve glucose utilization.
- b. In another study, 4 of 12 diabetics* treated with 1 mg chromium daily for 6 months had improved glucose tolerance, but 16 treated for a shorter period of time with 150 μg chromium daily did not improve.
- c. The majority of elderly subjects over the age of 70 years exhibit chemical evidence of impaired glucose tolerance. Ten such elderly subjects have been treated with 150 μg chromium daily for periods up to 4 months. No improvement was observed in six, but glucose tolerance was restored to within normal limit in the other four subjects.
- d. Fifty percent of a group of middle-age subjects with impaired glucose tolerance who

*Not reported fully by the author³ concerning the type of diabetes.

were treated with 150 µg chromium daily for 6 months, had a marked improvement in glucose tolerance.

- e. Trials of chromium-supplementation have also been undertaken with infants suffering from protein-calorie malnutrition, which is frequently complicated by disorders of carbohydrate metabolism manifested by fasting hypoglycemia or impaired glucose tolerance, or both. Hopkins, et al³⁸ reported that malnourished infants in some areas benefit from chromium treatment, but they also clearly show that not all cases of malnutrition are complicated by low chromium states.

The results of studies in at least four different countries indicate that in some, but not all, geographical regions, protein caloric malnutrition is complicated by chromium deficiency. By analogy with experimental animals, the protein deficiency of these patients probably accentuated the effects of chromium deficiency.

Chromium has been shown to be essential for the maintenance of normal glucose metabolism in several species of experimental animals. Several reports mentioned that man does require chromium but it is still difficult to recommend a specific daily allow-

ance because of the extreme variations of availability among different sources of chromium. If all the dietary chromium were in the form of the biologically active GTF, an intake of 10-30 μg would probably meet the requirement. Chromium in the form of simple salts is much less effective, and probably several hundred micrograms would-be required per day.

II. Experimental methods and results

II. 1. Serum chromium determination

A. Method of analysis

The most widely used method for trace elements determination in biological material in most laboratories is the atomic absorption spectroscopy method. This method is based on measurements of the intensity of radiation absorbed by unexcited atoms in the flame. With the use of special burners and by the use of organic solvents, the sensitivity of this method for measurement of chromium levels can be increased to 6 ng^{5,40}. The main drawback of this method is the preparation of samples. Both wet- and dry-ashing appear acceptable. Since the wet method is more rapid and leaves the chromium in solution it is used almost exclusively. Even so, sample preparation is not as simple as in neutron activation analysis and contamination of chromium from the environment is not easy to control.

Colorimetric procedure has been used in some laboratories to determine low chromium levels in biological materials. This method is based on the formation of colored complexes with reagent. Using 1,5-diphenyl-carbohydrazide as reagent a limit of 3.5 ng of chromium can be

determined^{5,40}. The main drawback of this method at such low chromium level is the instability of the color and interferences from other ions.

The use of x-ray fluorescence spectrometry, for analysis, was found to be deficient in several respects - especially the elemental range for analysis extends down only to an atomic number of about 25. Chromium, atomic weight 24, is just below this limit⁴¹. Also the chances for contamination from the environment during pre- and post-sample handling is large.

In this experiment neutron activation of Cr-50 (4.31% abundance) was used to determine the chromium level in human serum. The basic principle of neutron activation analysis is the production of radioactive isotopes of a desired element by neutron interaction with stable isotopes of the element, followed by the measurement of the radiations emitted. This method is chosen because of its high sensitivity and accuracy in detecting trace amount of chromium (down to several ppb with an error of about $\pm 15\%$) as well as its simplicity in preparing and handling of samples and because of the availability of the TRIGA Mark III Berkeley Research Reactor at the University of California, Berkeley campus.

B. Sample preparation and neutron irradiation

A sample of approximately 20cc of blood was drawn in a "chromium free"* centrifuge tube through a plastic needle. The sample was then centrifuged for 30 minutes at 3000 rpm. About 8cc of serum was transferred to another "chromium free" centrifuge tube by decanting the top layer of the centrifuged blood. The serum sample was then freeze-dried for approximately 24 hours. Precisely measured dried serum (in the range of 200 mg) was loaded, by direct pouring, into a high purity fused quartz tube and heat sealed.

The samples were then irradiated, together with samples of a known amount of chromium standard, in the TRIGA III reactor central thimble irradiation facility for 8 to 16 hours. The thermal neutron flux is approximately 3.5×10^{13} n/cm²-sec. A uniform flux was obtained by rotating the sample container periodically.

*In order to avoid trace-metal contamination of the serum specimen, all glassware including quartz tubes were cleaned with detergent, soaked in a solution of dilute HCl and HNO₃ and finally rinsed several times with distilled water. The distilled water with which the tubes were rinsed, was checked for its chromium content by neutron activation analysis. Within the limits of the ability of neutron activation analysis, no chromium contamination was detected.

Following irradiation the samples were cooled for about 14 days. This allowed all short half-life isotopes to decay. The quartz vial was then washed in boiling distilled water and frozen in liquid nitrogen before being broken open. This last procedure minimizes the escape of chromium to the environment during transfer of the irradiated serum to counting vials. Immediately after transfer the counting vials were sealed.

C. Gamma-ray analysis

The Cr-51, generated from neutron activation of Cr-50, which emits gamma rays of 0.321 MeV, was counted for up to 24 hour with a 35cc Ge(Li) detector (Canberra Inc.) and a 4096 channel pulse-height analyzer (Nuclear Data Inc.). The data collected were then analyzed at the LBL CDC-7600 computer using the program SAMPO. SAMPO is a computer program that analyzes the exact γ energy of any channel location, the area of the photopeak* and statistical and calibration uncertainties of these quantities.

D. Results

Using the above method, blood samples were

*The net counts of a specific γ -ray were obtained by integrating the area of the photopeak.

analyzed originating from several random subjects. The serum chromium levels found ranged from 2 ppb \pm 20% to 15 ppb \pm 8%. In two out of two trials, serum chromium levels were found to be higher after glucose intake relative to fasting.

II. 2. Serum chromium as a function of blood glucose and plasma insulin levels

Because serum chromium levels were found to be related to body glucose metabolism after glucose intake, the following experiments were performed to see if there was a consistent relation between serum chromium levels, blood glucose and plasma insulin values during different stages of the body glucose metabolism.

Three normal subjects and two patients with impaired glucose tolerance were given glucose tolerance tests. In addition to blood glucose, insulin and serum chromium levels were measured in each sample (table 1, fig. 1). Insulin was measured by radioimmunoassay and blood glucose by the modified Hossman method.

It was found that in all three normal subjects and the two patients, the fasting plasma chromium levels ranged from 2 ppb to 6 ppb. Peak levels of serum chromium were noted at 90 to 120 minutes after oral administration

BLOOD SERUM CHROMIUM LEVELS
(ng/g blood serum, wet weight)
AND ORAL GLUCOSE TOLERANCE TEST

<u>Subject-Diagnosis</u> <u>Sex - Age</u>	Fasting	30 min.	60 min.	90 min.	120 min.	180 min.
<u>Normal Subject #1</u> <u>Male - 40 y.</u>	5.8 _± 14%	7.9 _± 9%	12.6 _± 9%	14.9 _± 8%	11.2 _± 9%	8.9 _± 17%
<u>Normal Subject #2</u> <u>Male - 28 y.</u>	2.2 _± 19%	6.3 _± 10%	11.1 _± 9%	12.0 _± 9%	11.4 _± 9%	6.2 _± 14%
<u>Normal Subject #3</u> <u>Male - 48 y.</u>	1.9 _± 18%	10.3 _± 13%	10.1 _± 15%	10.6 _± 9%	10.8 _± 11%	6.9 _± 19%
Normal Subject #4	6.1 _± 8%					
Normal Subject #5	8.1 _± 11%					
<u>Acromegalic Diab.</u> <u>Male - 45 y</u>	2.8 _± 17%	4.9 _± 14%	5.4 _± 9%	9.3 _± 14%	12.4 _± 8%	5.2 _± 10%
<u>Mature Onset Diab.</u> <u>Male - 40 y.</u>	4.5 _± 21%	4.4 _± 23%	7.9 _± 11%	9.8 _± 10%	12.6 _± 8%	5.6 _± 18%
Hemochromatotic #1	6.9 _± 18%					
Hemochromatotic #2	4.3 _± 23%					

Table 1

00304606592

of 100 gm of glucose; the levels ranged from 9 ppb to 15 ppb (fig. 1). Glucose and insulin peaks in normal subjects were reached almost at the same time, i. e., at approximately 30 minutes after glucose intake, while in the patients with impaired glucose tolerance they occurred after 60 to 90 minutes. Analysis of the data also showed that in both normals and patients with impaired glucose tolerance a delay occurred, the chromium reachings its peak after glucose and insulin. The differences noted in the pattern of the serum chromium response curves between normal and impaired patients was the difference in the rate of increase of chromium response during the first hour after glucose intake (faster in normals), followed by a peak which was delayed compared to normals (fig. 1).

II. 3. Serum radiochromium(III) clearance

Serum radiochromium(III) clearance experiments were performed in three normal subjects and three hemochromatotic patients (Appendix B). Blood was periodically drawn from patients starting seconds after 100 μCi of $^{51}\text{CrCl}_3 \cdot 6\text{H}_2\text{O}$ was injected up to a period of 60 days. Intervals between drawing ranged from 3 minutes to 14 days.

BLOOD SERUM CHROMIUM AND INSULIN RESPONSE
AND
ORAL GLUCOSE TOLERANCE TEST

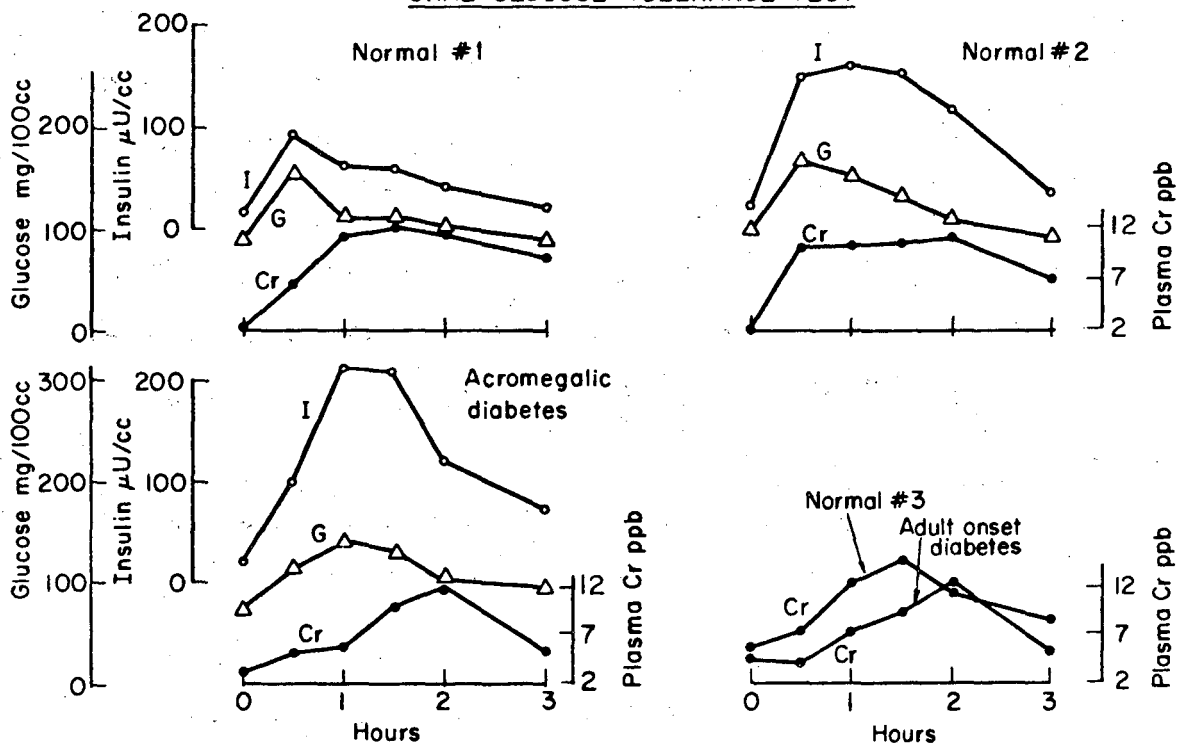

XBL7612-11440

Fig. 1

The blood was centrifuged for approximately 30 minutes at 3000 rpm. Following centrifugation the plasma was ultracentrifuged for approximately 24 hours at 114,000g and 17°C. Under these conditions plasma protein sedimented to the bottom, leaving a relatively protein-free supernatant.

During the 60 days the experiment was performed, it was found that most radioactive chromium(III) is bound to serum protein with m.w. larger than 90,000. Some unbound radiochromium(III) was also found. As is well known, chromium(III) in blood is bound to transferrin (m.w. 90,000)^{11,42}.

During the first minutes post injection the average free radiochromium(III) portion ranged from approximately 25% in some patients with hemochromatosis to approximately 4% in most normal subjects. After this transient period the percentage levelled off to approximately 10% in hemochromatosis compared to approximately 3% in normals. This number remains constant for several days, beyond which the unbound radiochromium(III) could no longer be determined accurately due to its very low

level of activity (fig. 2,3). Surprisingly, from our in vitro experiment when plasma incubated with physiological amounts of $^{51}\text{CrCl}_3 \cdot 6\text{H}_2\text{O}$ was ultracentrifuged, the same percentages (approximately 25% in hemochromatosis and approximately 4% in normals) of free or unbound radiochromium(III) was found.

Least square fit to the plasma radiochromium(III) clearance data in 3 normals resulted in at least 5 detectable exponential clearance components with respective average half-lives of: 57 minutes*, 4.1 hours*, 18 hours*, 6.7 days*, and 11 months*** (table 2). The first component is believed to be related to the rapid accumulation of radiochromium(III) in the liver, adipose and muscle tissues, the spleen and some in bone.

The second component is probably associated with the clearance of dialyzable chromium(III) through the kidney into the urine.

The third and fourth components might be related to the slower accumulation or uptake by the liver, both adipose and muscle tissues, spleen and bone.

* Determined from experimental data

** Based on the final slope calculated from whole body excretion data.

PLASMA ^{51}Cr (III) CLEARANCE HALF-LIVES

<u>SUBJECT #</u> <u>SEX-AGE</u>	Diagnosis	(T-1/2) ₁ *	(T-1/2) ₂ *	(T-1/2) ₃ *	(T-1/2) ₄ *	(T-1/2) ₅ **
<u>N #1</u> <u>M - 38y</u>	Normal	50m(45%)	3.9h(19%)	17h(19%)	6.2d(17%)	330d(<1%)
<u>N #2</u> <u>M - 27y</u>	Normal	60m(32%)	3.6h(19%)	16h(26.5%)	7.1d(22%)	230d(<1%)
<u>N #3</u> <u>M - 40y</u>	Normal	60m(25.5%)	4.8h(26%)	20h(27.5%)	6.8d(21%)	444d(<1%)
<u>H #1</u> <u>F - 31y</u>	Hemochr.	20m(47%)	1.5h(30.0%)	11.4h(15%)	4.6d(8.0%)	206d(<1%)
<u>H #2</u> <u>F - 54y</u>	Hemochr.	30m(45%)	2.0h(30.0%)	10h(17.5%)	6.6d(7.5%)	135d(<1%)
<u>H #3</u> <u>M - 38y</u>	Hemochr. (early stages)	80m(34.0%)	4.8h(23.0%)	18.2h(19.0%)	6.5d(24%)	305d(<1%)

* Least square fit to plasma ^{51}Cr (III) clearance curve

** Determined from the final slope calculated from whole body excretion data
m: minutes; h: hours; d: days

Table 2

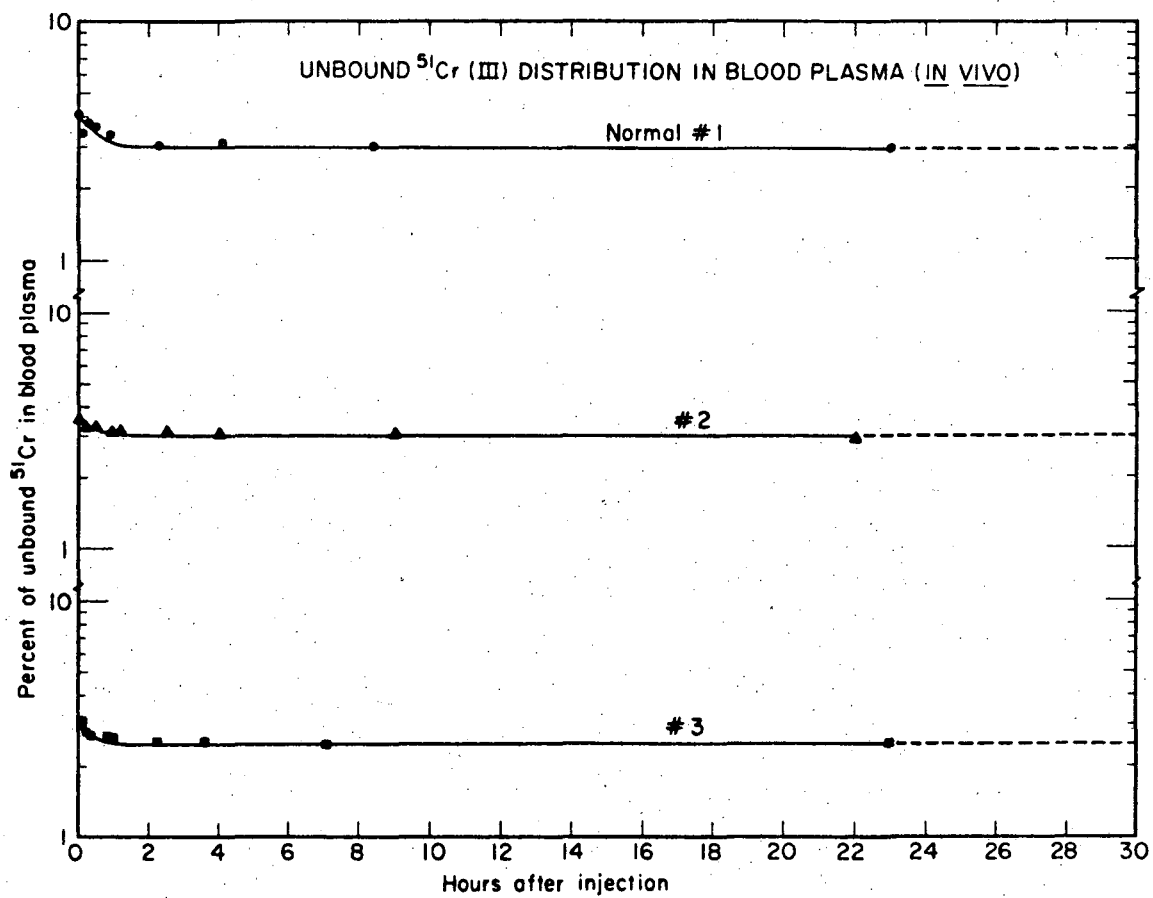

XBL7612-10740

Fig. 2

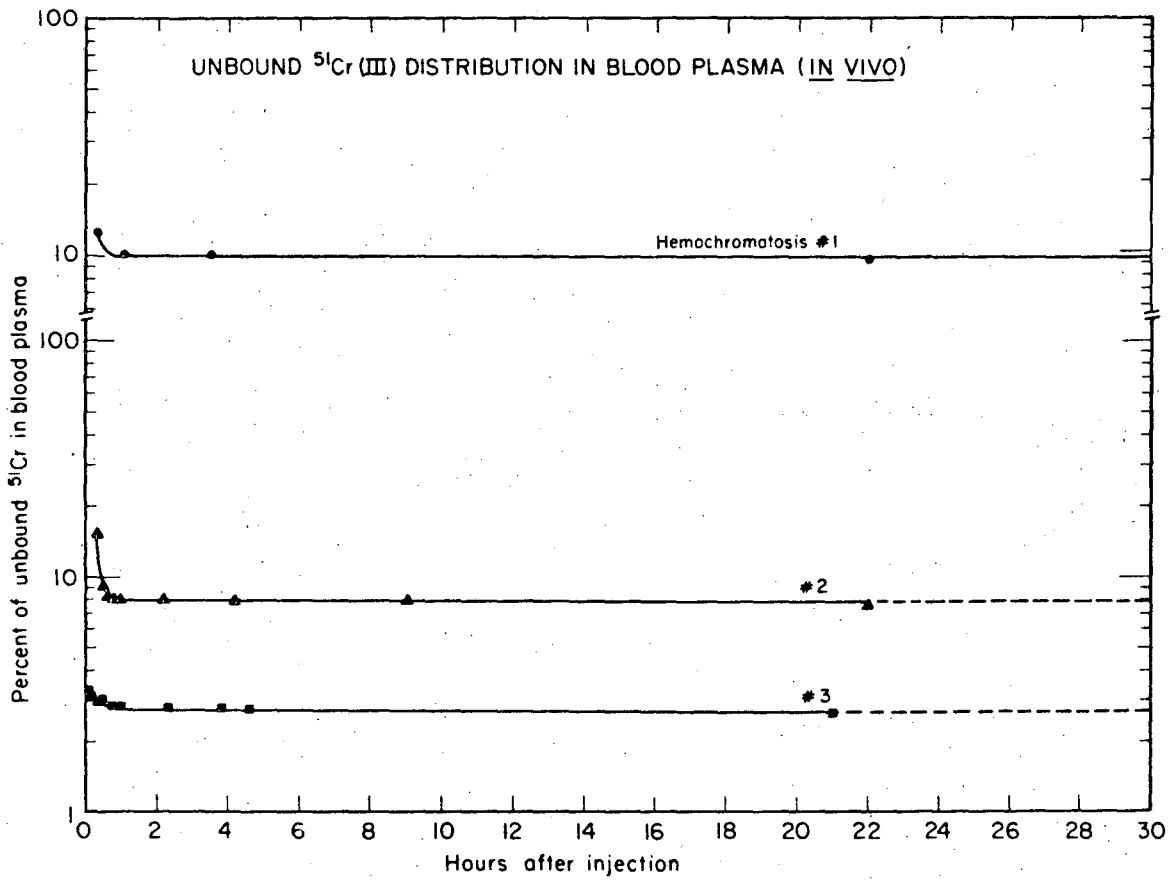

XBL 7612-10741

Fig. 3

The last component has its logical origin from the clearance of stored chromium(III) into the urine. The average clearance in 3 patients with hemochromatosis occurred more rapidly than in normal subjects (table 2).

The fact that in vitro incubation of radio-chromium(III) with plasma gave approximately the same free to total plasma chromium(III) ratio compared to in vivo and the fact that a quite linear relation exists between free plasma chromium(III) concentration and bound plasma chromium(III) concentration at steady state condition (fig. 2,3), indicated that free chromium is "produced" or at least exists all the time in human blood plasma.

The existence of free chromium(III) at all times can only be explained by assuming that exchange of free and bound chromium(III) takes place; this suggests that the plasma chromium(III) pool consists of a free or unbound or dialyzable chromium(III) subpool and a plasma or transferrin bound chromium(III) subpool. (As is well known and mentioned earlier chromium(III) is primarily bound in blood plasma to transferrin.)

II. 4. Serum radiochromium(III) response and glucose tolerance test

On several occasions, 14 days after administration of 100 μ Ci of $^{51}\text{CrCl}_3 \cdot 6\text{H}_2\text{O}$ intravenously, a glucose tolerance, insulin and radiochromium(III) response test was performed. Blood was drawn at 30 minute intervals for 3 hours. Radioactivity was found to decrease gradually during the whole test (fig. 4). No increase in radiochromium(III) levels was noted during the 3 hours the glucose tolerance test was performed (both, in patients suffering from hemochromatosis and normal subjects). It is important to note that in the separate experiment described in II.2 the total plasma chromium was higher after glucose administration relative to fasting while in this test only injected radiochromium(III) was measured.

II. 5. Radiochromium(III) localization, whole body scanning and whole body counting

At the present time, the whole body scanner is the best instrument available for visualization of radiochromium(III) in the human body. Localization of radiochromium(III) in the human body was performed at LBL Donner Laboratory of the University of California

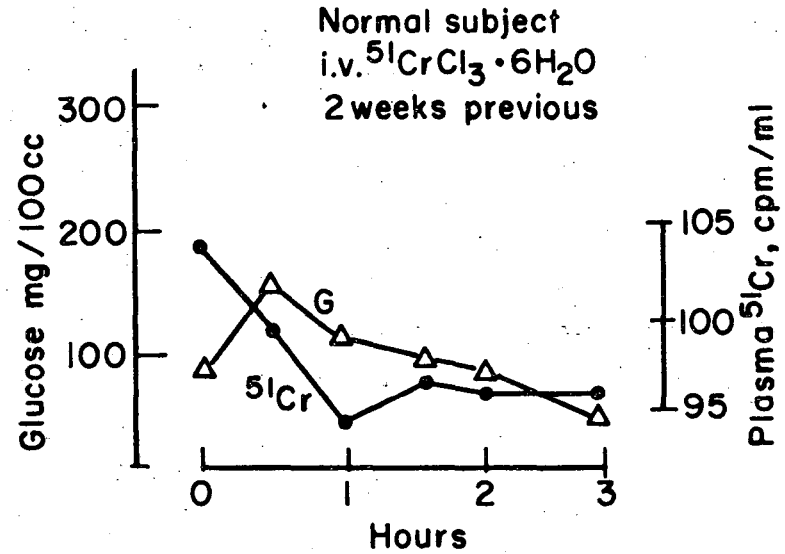
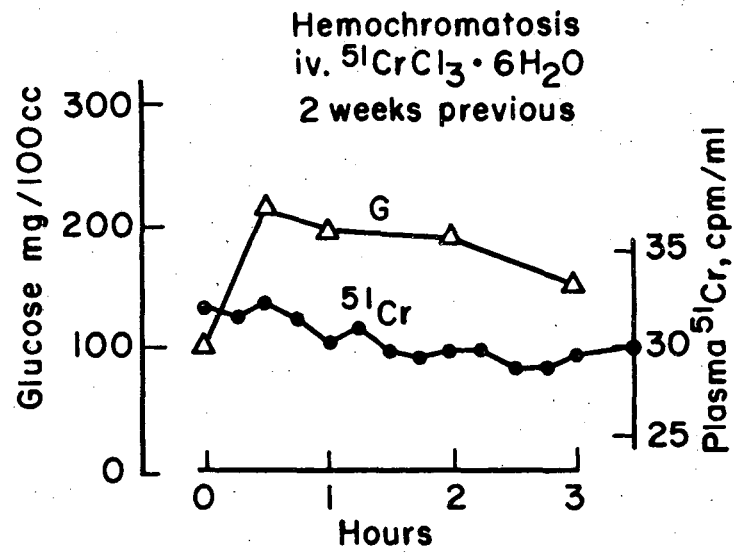

Glucose Tolerance and Serum Radiochromium (III)
Response Tests

Fig. 4

XBL771-3010

7165904000

in 3 normal and 3 hemochromatotic subjects (appendix B).

The Mark II computerized rectilinear whole body scanner was used. The scanner has recently been interfaced to a Hewlett Packard 5407A Scintigraphic Data Analyzer, which allows acquisition of data for further analysis⁴³. The scanner operates by moving the patient over an array of 4 rows of 16 2.5 x 2.5 cm (NaI(Tl)) crystal detectors (fig. 5). Since there were no previous experience in the conduct of this experiment, especially to what extent the physical preparation of the subjects has to be, subjects were asked to follow their regular routine activities prior to and during the course of the experiment.

Subjects were periodically scanned starting seconds after 100 μ Ci of $^{51}\text{CrCl}_3 \cdot 6\text{H}_2\text{O}$ was administered intravenously, up to a period of 90 days. Scan duration varied from 3 to 44 minutes, both anterior and posterior. Intervals between scanning ranged from 3 minutes to 14 days.

From scan images, radiochromium(III) was localized primarily in the liver, body soft tissue, spleen, and bones (figs. 6,7,8,9,10,11).

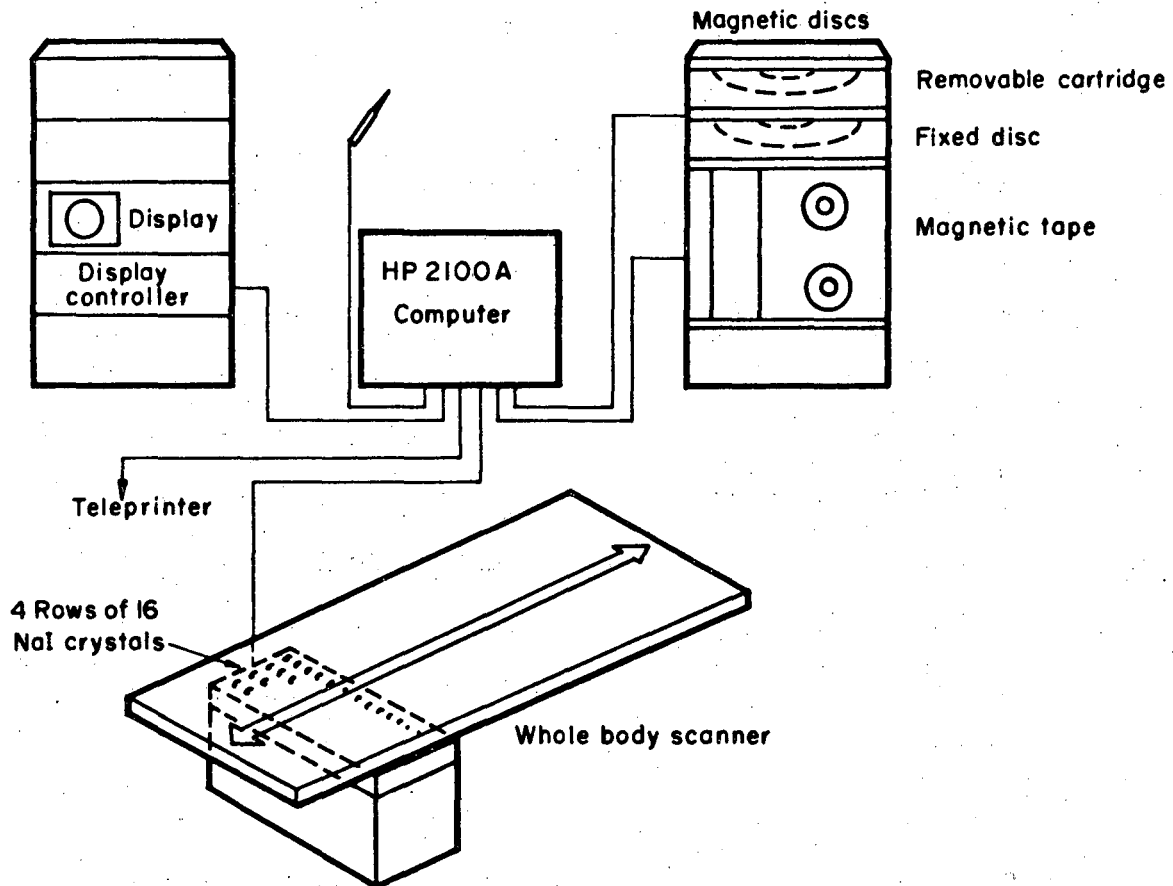

THE MARK II COMPUTERIZED RECTILINEAR WHOLE-BODY SCANNER

XBL771-3061

Fig. 5

For a period up to 6 months the total radiochromium remaining in the body as a function of time was determined with the Donner Laboratory whole body counter.

A. Liver Chromium(III) (fig. 10,11)

Concentration of radiochromium(III) in the liver was found to be the highest among all of the body organs. Examination of a semi-log plot of data points (fig. 12), suggest that the liver radiochromium(III) clearance curve (blood activity subtracted) consists of at least a fast* and slow* exponential component. Absorption also occurred through both rapid and slow exponentials. Rapid absorption and clearance suggest the existence of a labile chromium(III) subpool in the liver. Slow absorption and clearance of chromium(III) suggest the existence of a chromium(III) storage subpool.

It was also found that clearance of radiochromium(III) from this organ occurred more rapidly in patients with hemochromatosis (fig. 13, 14).

*"fast", "medium" and "slow" clearance or uptake is related to half-lives within a range of respectively 0.5-12 hours, 1-14 days, and 3-12 months.

Cr⁵¹ Distribution (Anterior)
NORMAL MALE SUBJECT #2
Cr⁵¹ Cl₃ Intravenously
Mark II Whole Body Scanner

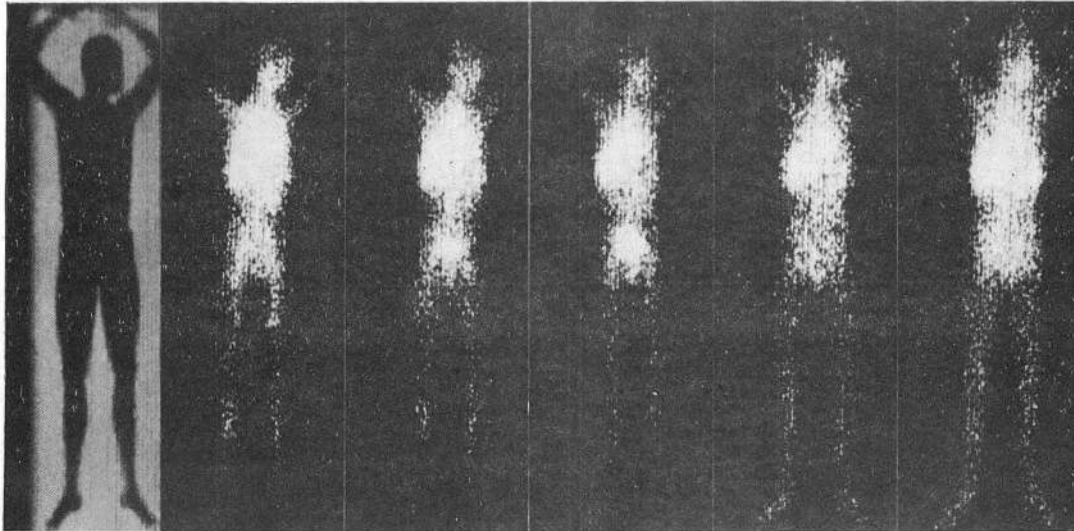

Am 241
Transm

3 min

1 h

4 h

1 d

5 d

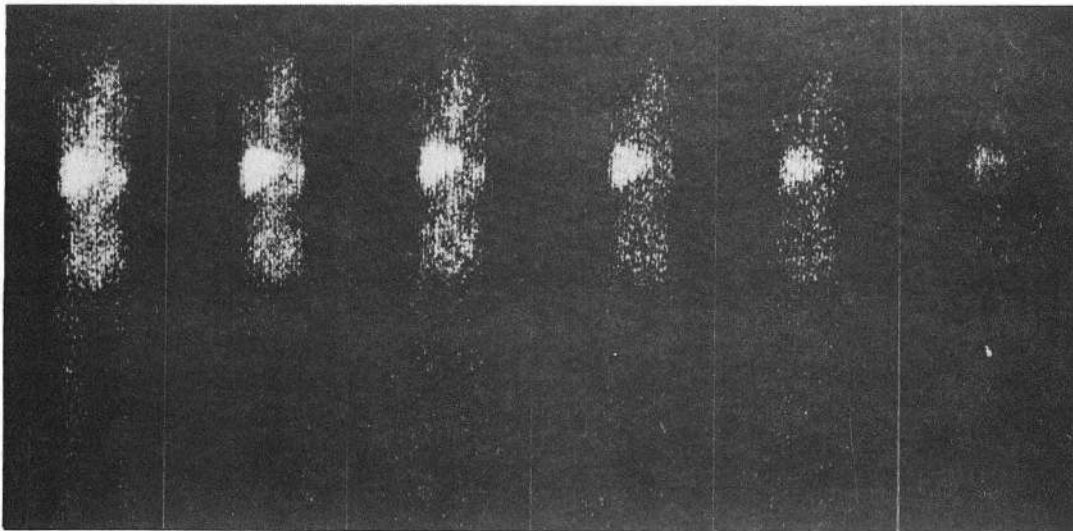

15 d

28 d

46 d

56 d

70 d

84 d

XBB 768-7589

Fig. 6

Cr⁵¹ Distribution (Posterior)
NORMAL MALE SUBJECT #2
Cr⁵¹ Cl₃ Intravenously
Mark II Whole Body Scanner

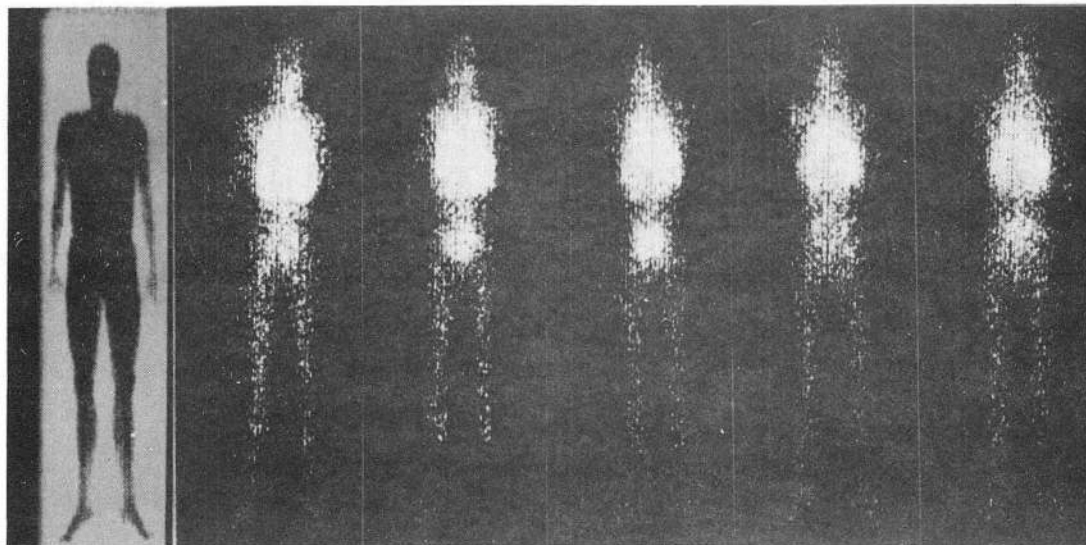

Am 241
Transm

20 min

1 h

4 h

8 h

1 d

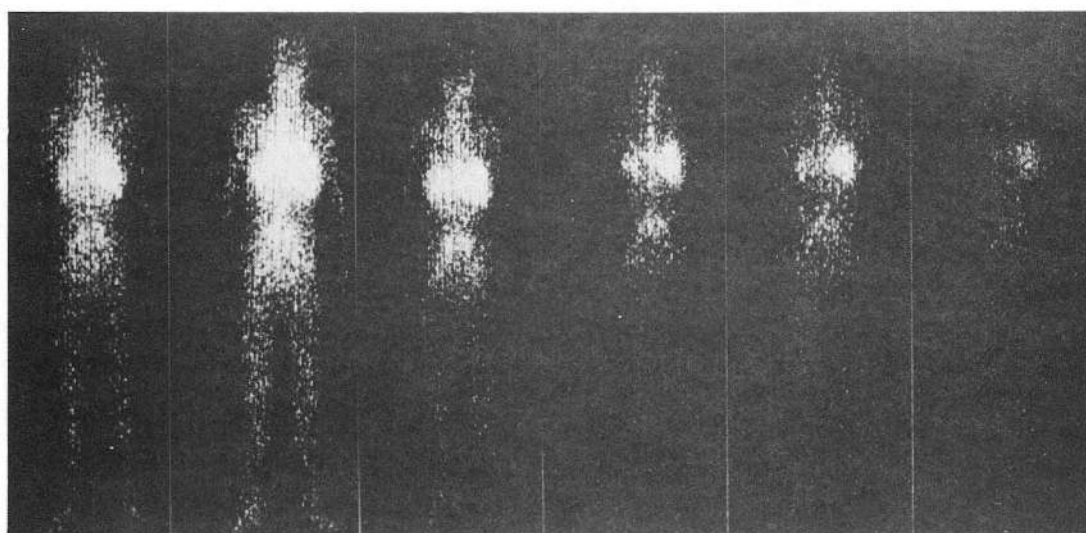

2 d

5 d

15 d

28 d

56 d

84 d

Fig.7

XBB 768-7590

Cr^{51} DISTRIBUTION
(Anterior)
EARLY ENDOGENOUS HEMOCHROMATOSIS
 $Cr^{51}Cl_3$ INTRAVENOUSLY
Mark II Whole Body Scanner

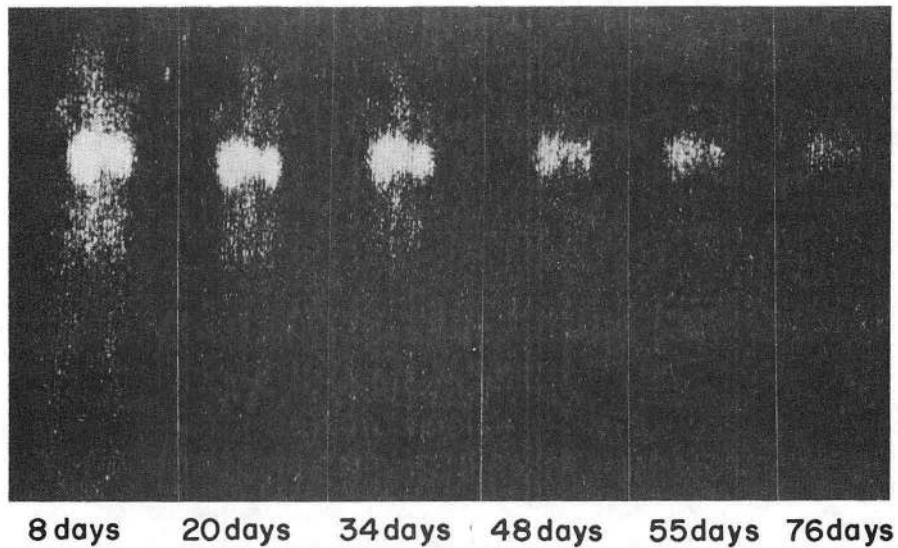
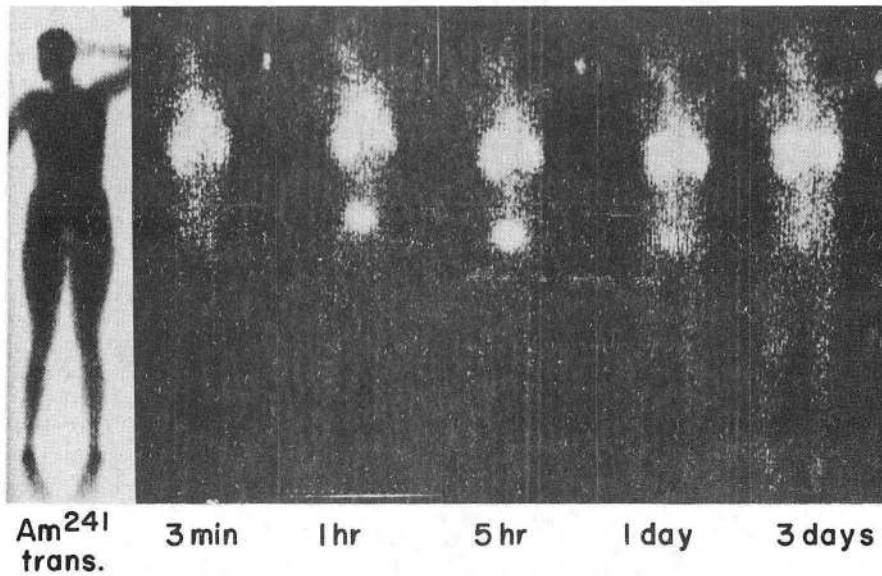

XBB 765-4027

Fig. 8

Cr^{51} DISTRIBUTION
(Posterior)
EARLY ENDOGENOUS HEMOCHROMATOSIS
 $Cr^{51}Cl_3$ INTRAVENOUSLY
Mark II Whole Body Scanner

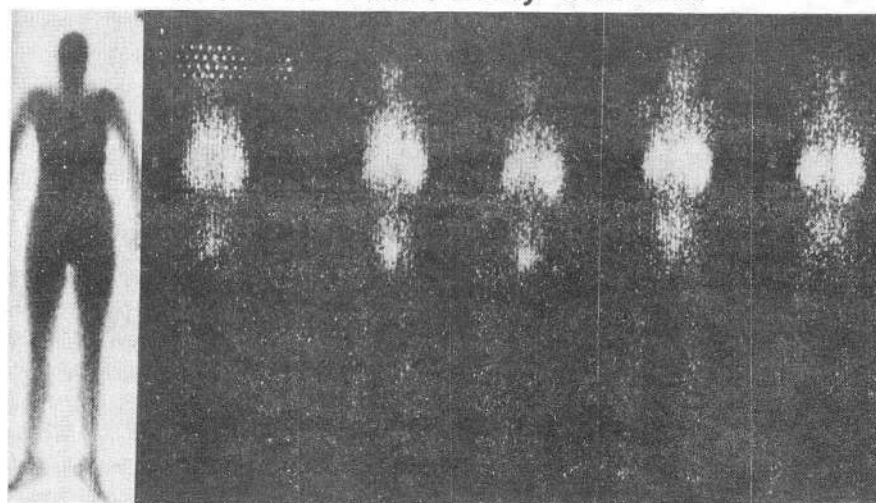

Am^{241}
trans.

8 min

2 hr

8 hr

2 days

8 days

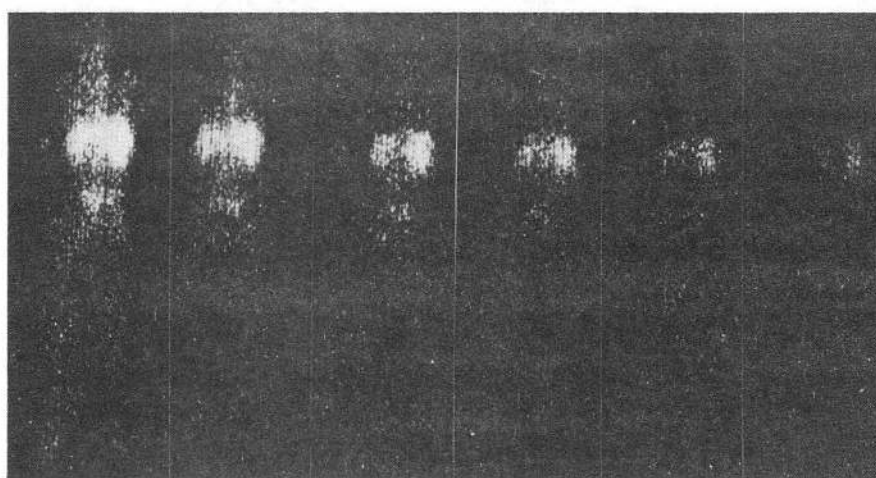

20 days

34 days

48 days

55 days

69 days

76 days

XBB 765-4028

Fig. 9

⁵¹Cr DISTRIBUTION IN DIFFERENT ORGANS

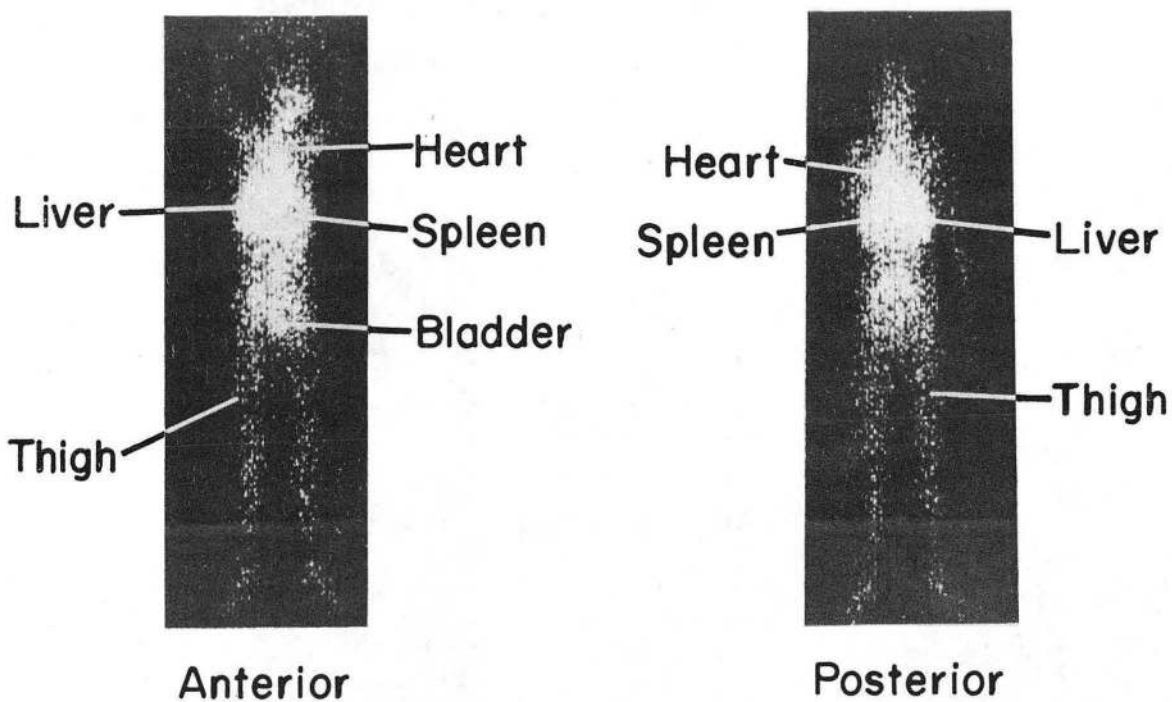

Normal Subject
2 Days post-injection

XBB 760-11069

Fig.10

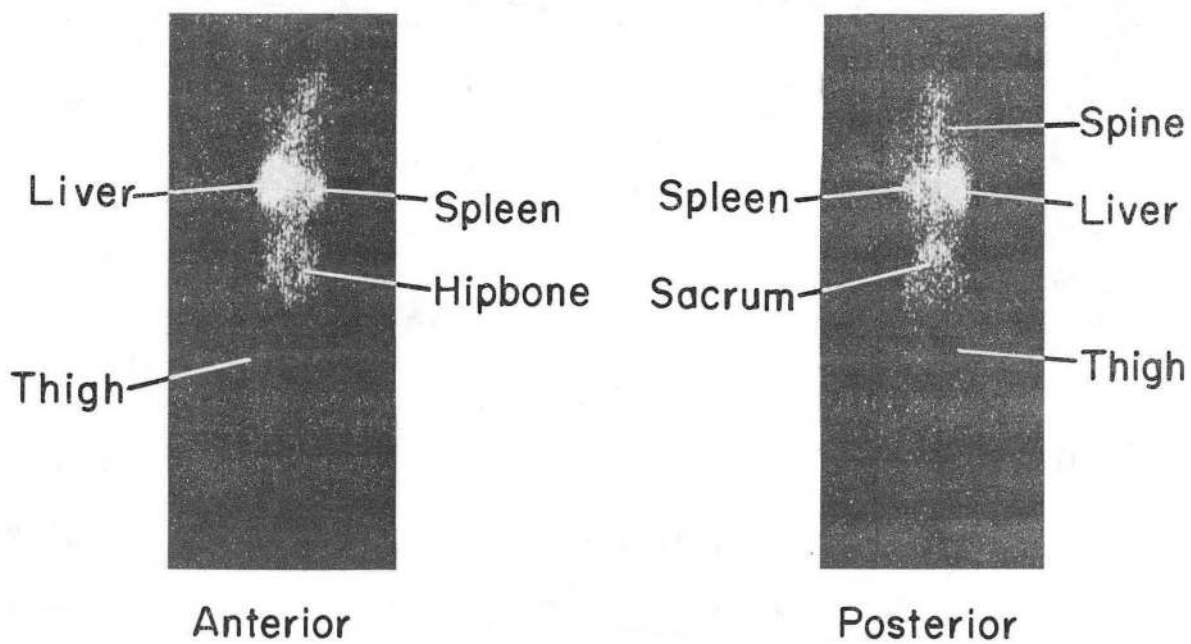
^{51}Cr DISTRIBUTION IN DIFFERENT ORGANS

Normal Subject
28 Days post-injection

XBB 760-11070

Fig. 11

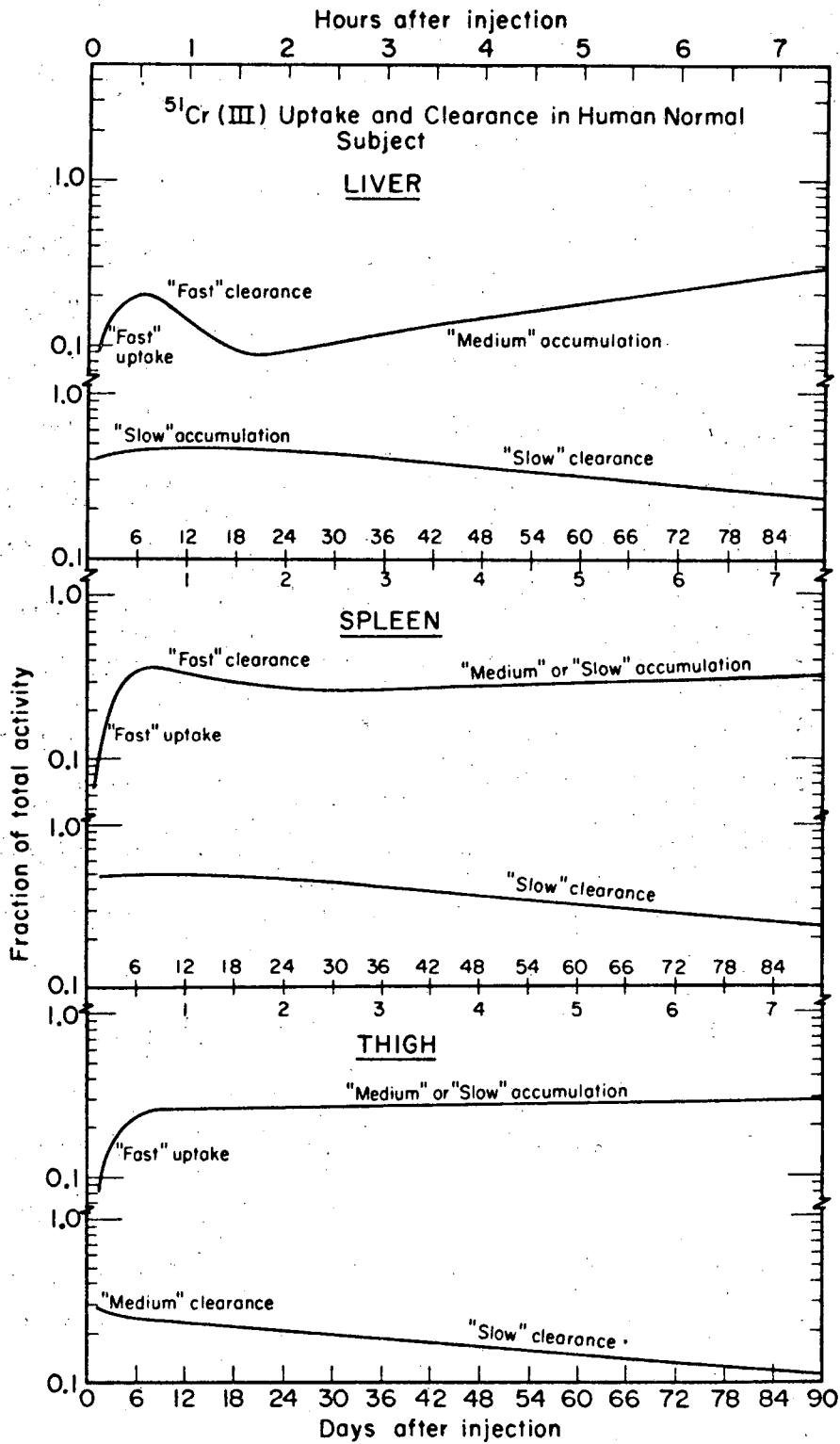

XBL771-3003

Fig. 12

B. Adipose and muscle tissue chromium(III)
(fig. 10,11)

Examination of radiochromium(III) clearance curve from the thigh (fig. 12) suggests that this organ cleared radiochromium(III) through at least a rapid and slow exponential. Examination of radiochromium(III) clearance curve (blood activity subtracted) and scan-images suggest that a medium* exponential absorption component existed besides the slow. Accumulation of chromium(III) in adipose and muscle tissues is described by ref. (17) as primarily related to the transport of glucose across cell membranes. Furthermore, it is suspected that chromium(III) is involved in lipid and protein metabolism¹⁷.

C. Spleen chromium(III) (fig. 10,11)

Absorption and clearance of radiochromium (III) in the spleen followed a combined pattern as does absorption and clearance in the liver and soft tissues. Clearance occurred through exponentials with approximately the same half-lives as the liver (fig. 12).

D. Bone (fig. 10, 11)

Radiochromium(III) can be considered as

* See footnote on page 34.

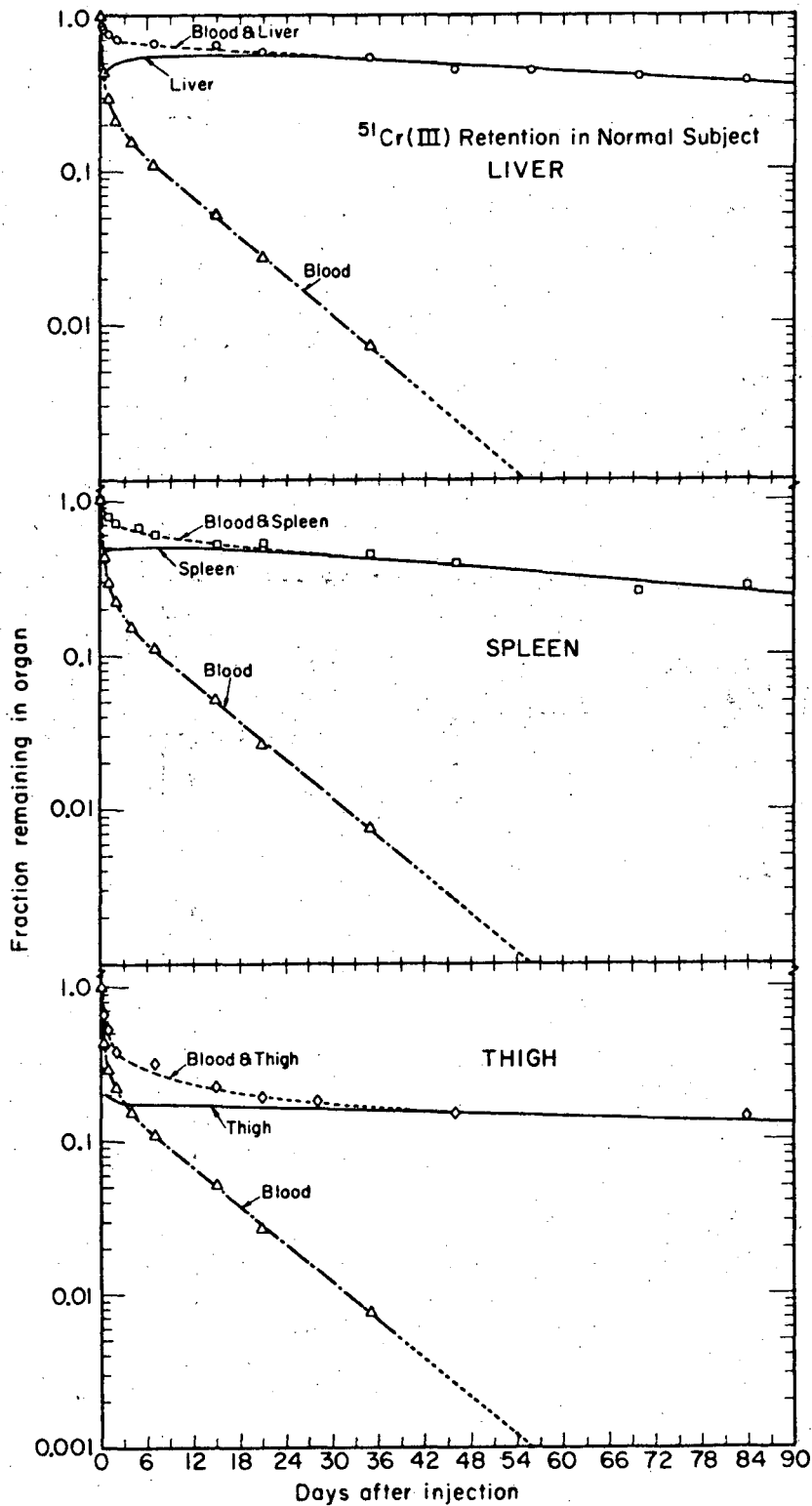

XBL7610-9412

Fig. 13

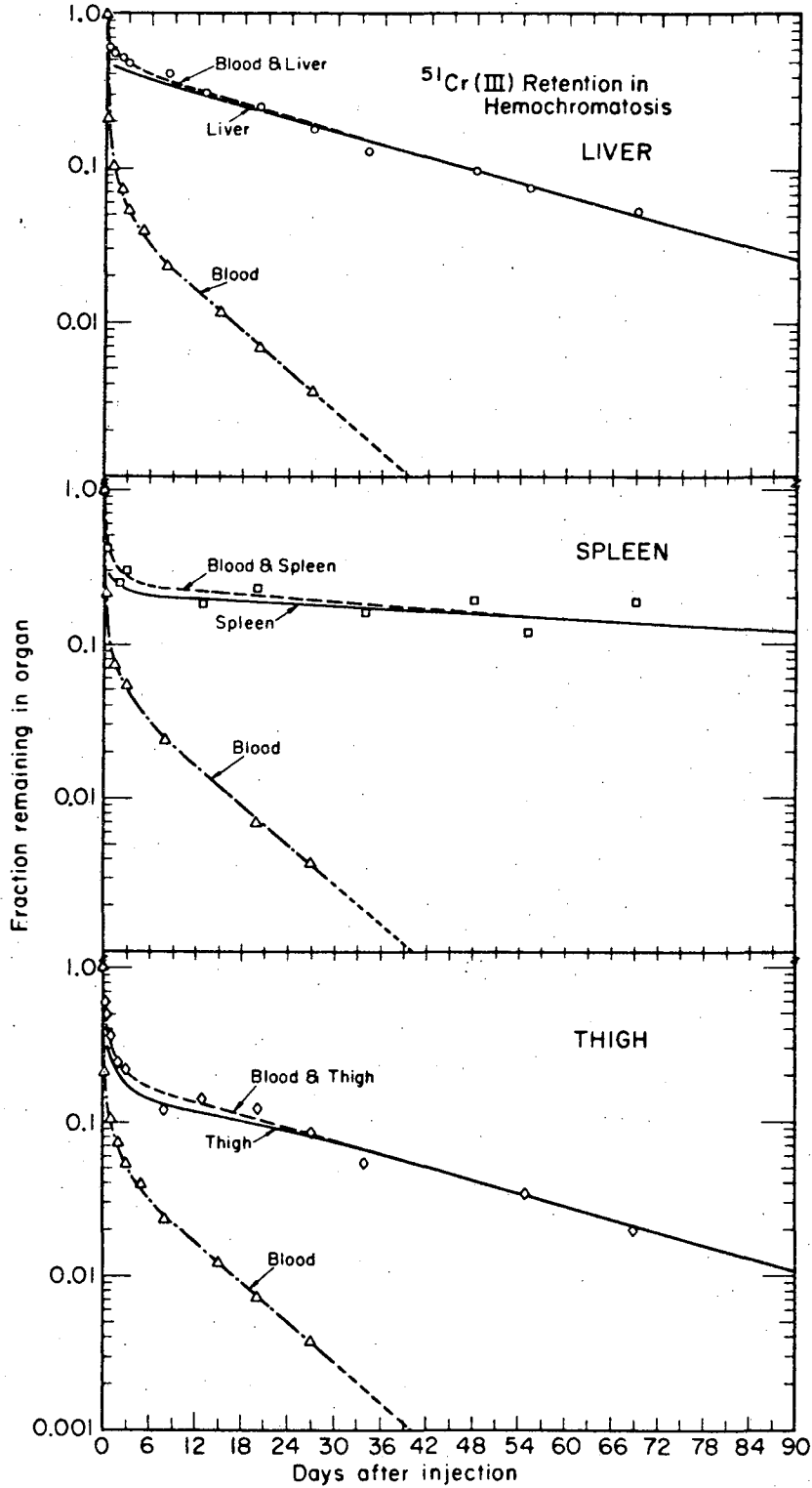

Fig. 14

an inferior boneseeker*; accumulation in the joints was detected in a patient suffering from arthritis (fig. 15). Fast accumulation of radiochromium(III) in bones cannot be detected successfully probably due to the high activity of radiochromium(III) in the blood and soft tissues.

E. Other organs (fig. 10,11)

Accumulation of radiochromium(III) in other organs of the body, such as the kidneys, lungs, central nervous system and the heart cannot be detected with the present experimental techniques. This is primarily due to the high activity of the circulating blood compared to the probably low concentration of radiochromium(III) accumulated in the above mentioned organs especially during the first day of the experiment.

F. Whole body chromium(III) (fig. 6,7,8,9, 10,11)

In general body tissues absorbed radiochromium(III) very rapidly. More than 50% of blood plasma chromium(III) was absorbed by different body organs within hours after intravenous administration. Clearance was

*visually the concentration in bone is rather small compared to F-18.

⁵¹Cr (III) DISTRIBUTION IN HEMOCHROMATOSIS SUFFERING FROM ARTHRITIS

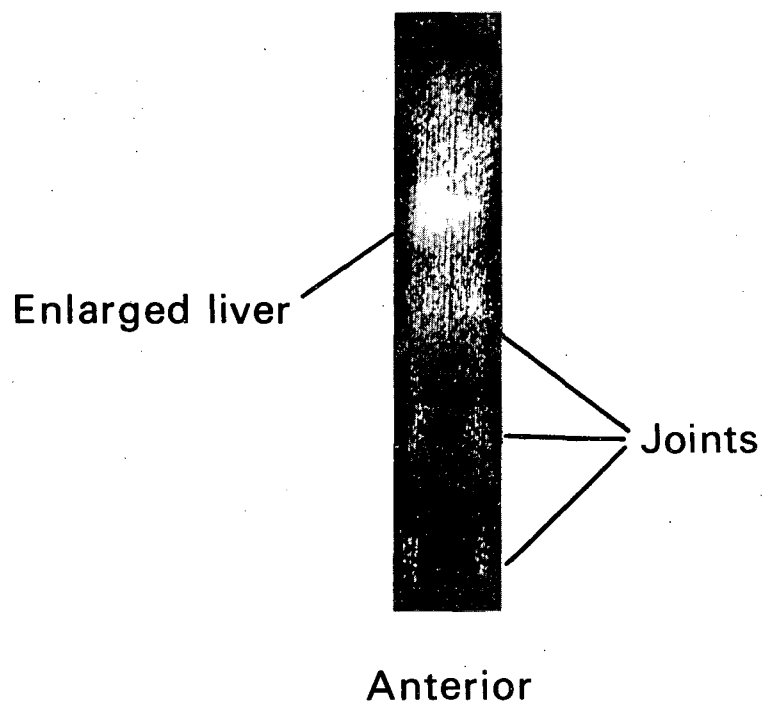

4 DAYS POST-INJECTION

Fig.15

XBB 771-50

more rapid in patients suffering from hemochromatosis compared to normals. Rapidity of clearance from the body depends on the concentration of free chromium(III) in blood plasma.

Radiochromium(III) 6 months after administration is most concentrated in the liver, about half of it was estimated, being in this organ and the remainder distributed in other body tissues. The excretion at this time is dominated by the slow rate component.

II. 6. Data analysis

A. Serum radiochromium(III)

Blood was drawn seconds after intravenous administration of $^{51}\text{CrCl}_3 \cdot 6\text{H}_2\text{O}$, up to a period of 2 months. Intervals between drawing varied from 3 minutes to 2 weeks. During the first 24 hours approximately 10 blood samples of approximately 20cc each were drawn. The plasma was then separated from the blood cells and ultracentrifuged for approximately 24 hours at 114,000g and 17°C. The portion of unbound or free radiochromium(III) was then determined by counting the top two-thirds (supernatant) of the ultracentrifuged plasma separately. The bottom part contained the plasma bound radiochromium(III). After several days the unbound portion of radiochromium(III) cannot

be determined any longer accurately, unless at least several hundred cc's of blood are drawn, since the activity is below the detection limit of our 4 x 9" NaI(Tl) crystal detector. The total plasma radiochromium(III) activity was determined by counting 20cc or more (up to 500cc in hemochromatosis obtained in the course of phlebotomy therapy) of whole blood directly; the plasma portion of the blood was determined from the hematocrit.

The data points obtained from both free and plasma bound radiochromium(III) are estimated to be accurate to within counting statistics and pipetting errors only(<5%).

B. Localization of radiochromium(III)

Determination of radiochromium(III) localization in different human organs was performed using the Mark II computerized rectilinear scanner. From scan images, concentrations of radiochromium were detected in the liver, soft tissue, spleen and bones.

The assumption was made that counts over the liver, spleen or bone includes counts from radioactivity within the liver, spleen or bone cells and counts from blood circulating in the organ. Counts over the body soft tissue include counts from radioactivity within the

soft tissue cells and the circulating blood only. Correction for the activity from circulating blood is made by subtracting the circulating blood counts in that region of the organ of interest from the total counts (fig. 13,14). Also the assumption was made that at time $t=0$, the total counts were contributed by the circulating blood alone, and that none had accumulated in the cells of the organ of interest. Other corrections include background and radioactive decay.

As mentioned above, absolute determination of radiochromium(III) in any organ of interest is quite complicated and with the present available techniques is far from accurate. Also, during the first several minutes post injection rapid accumulation and excretion of radiochromium occurred. Successive prone and supine scans cannot be performed synchronously with the Mark II scanner. Since the minimum scanning time for this experiment is 3 minutes, successive scans have a minimum time difference of at least 3 minutes. Applying a geometric mean and source thickness correction by using two conjugate views^{43,44,45} leads to a rather large error. For this reason source thickness and geometric mean corrections were not applied.

The total counts originating from activity present in any organ of interest, were obtained by integrating the area of the scan-image of the organ of interest^{43,44}.

Since the activity of the organ of interest was obtained on a semi-quantitative basis and cannot be used as an accurate input to match a proposed compartment model, other more accurate input data were chosen. These are the total body radiochromium(III) retention and plasma radiochromium(III) clearance data.

III. Chromium(III) compartment model and kinetics

III. 1. Schematic of proposed pathway

On the basis of data obtained from radiochromium(III) localization in different body organs, whole body counting, plasma radiochromium(III) clearance experiments and ultracentrifugation of labeled blood plasma, a schematic diagram showing chromium(III) pathway in the human body was proposed (fig. 16).

Transportation of chromium(III) is by the plasma protein, transferrin. Chromium (III) is believed to be stored primarily in the liver. Utilization of chromium(III) is suspected to be primarily by body soft tissue¹⁷. Excretion of dialyzable chromium (III) is through the kidney into the urine.

III. 2. Proposed physiological compartment model

The proposed chromium(III) pathway in the human body combined with results obtained from plasma radiochromium(III) clearance, suggest a multicompartiment physiological model for chromium(III) kinetics as show in fig. 17.

The model considered blood plasma chromium(III) as the "central compartment." The plasma chromium(III) compartment con-

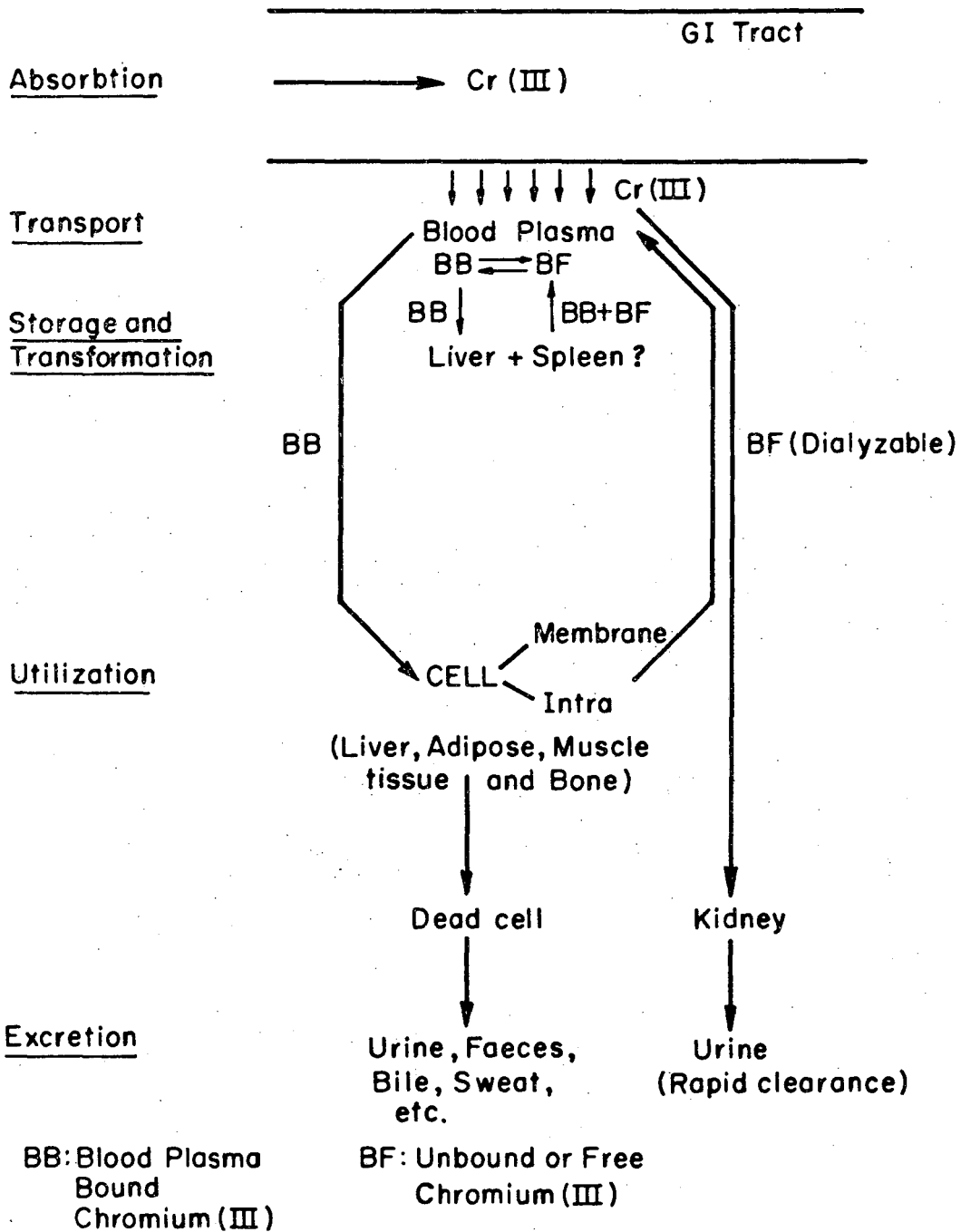

PROPOSED CHROMIUM (III) METABOLIC PATHWAY

Fig. 16

XBL7612-10739

sists of two subcompartments, the free or unbound chromium(III) and the protein bound chromium(III) subcompartment. Exchange of chromium(III) exists between the two subpools. The soft tissue chromium(III) pool probably consists of primarily adipose and muscle tissue. Possible tissue chromium(III) subpools would include cell membrane and inner cell organelles.

The liver consists also of two subcompartments. The first subcompartment has a fast turn-over and is called the "labile" subcompartment. The second subcompartment stores chromium(III) and releases it back to the blood plasma probably upon demand; this is called the storage subcompartment. The spleen has a clearance characteristic which suggest that it also stores radiochromium(III). The half-life of storage of radiochromium(III) in the spleen is approximately the same as the liver storage.

A bone chromium(III) compartment was added to the model since scan images indicated accumulation of radiochromium in the bones. To complete the model a hypothetical compartment consisting of organs that accumulate or absorb chromium(III) but can-

not be detected with the present imaging techniques was added.

III. 3. Mathematical model and computing method

A. Mathematical model

Results obtained from various experiments mentioned earlier provided some presumptive information on the physiological model and how the compartments are interconnected. The model consists of at least 6 compartments as described in fig. 17. Some compartments have subcompartments.

The five detectable exponential components of plasma radiochromium(III) clearance compared to at least six detectable different organs which accumulate radiochromium(III) can only be explained by assuming that some organs metabolize chromium(III) with approximately the same time constant⁴⁶. Estimates of liver, spleen and thigh accumulation of radiochromium(III) confirmed this statement. (fig. 12,13,14) .

The chromium(III) pool in adipose as well as in muscle tissues cannot be determined by the experimental techniques used. Quantitative data for the liver, spleen and bone cannot be obtained as accurately as the whole body retention and plasma radio-

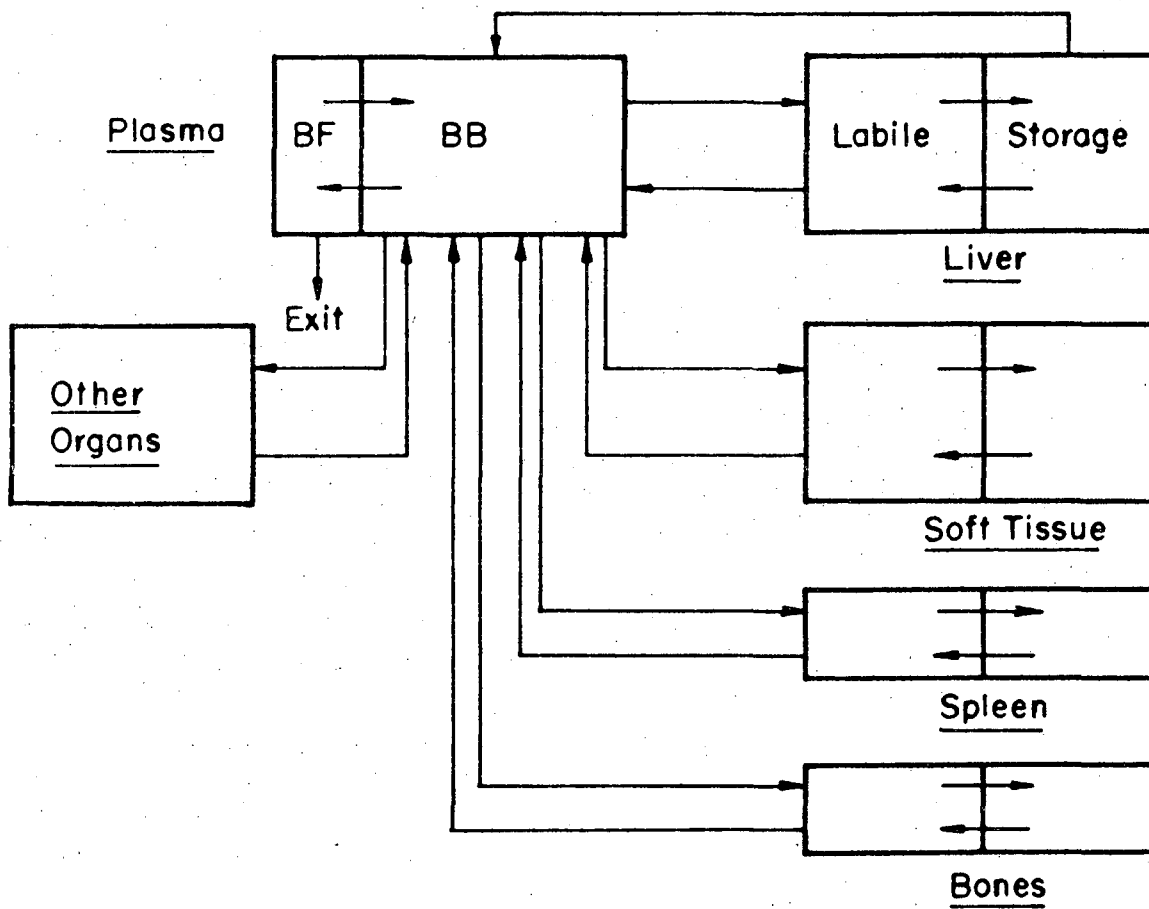

PROPOSED CHROMIUM (III) PHYSIOLOGICAL MODEL

XBL7612-10738

Fig. 17

chromium(III) clearance data points. For this reason a mathematical model was developed which grouped all physiological compartments accumulating chromium(III) with the same or almost the same time constant into one particular compartment. Since analysis of the plasma chromium(III) clearance data yields 5 detectable time constants with respective average half-lives (in 3 normals) of ~60 minutes, ~4 hours, ~18 hours, ~7 days, and ~11 months, the different hypothetical compartments in the mathematical model can at least be characterized by Fast*, Medium* and Slow*. Other intermediate compartments such as Fast-Medium or Medium-Slow can be added if necessary (fig. 18). All hypothetical compartments are assumed to be related linearly to the central compartment. The Fast compartment includes the fast or labile subcompartments of the bone, muscle, and adipose tissues, the spleen, and the liver. The Medium compartment represents the slower accumulation of chromium(III) in the spleen and the slower absorption of chromium(III) in either the liver, soft tissue and/or bone.

* See footnote on page 34.

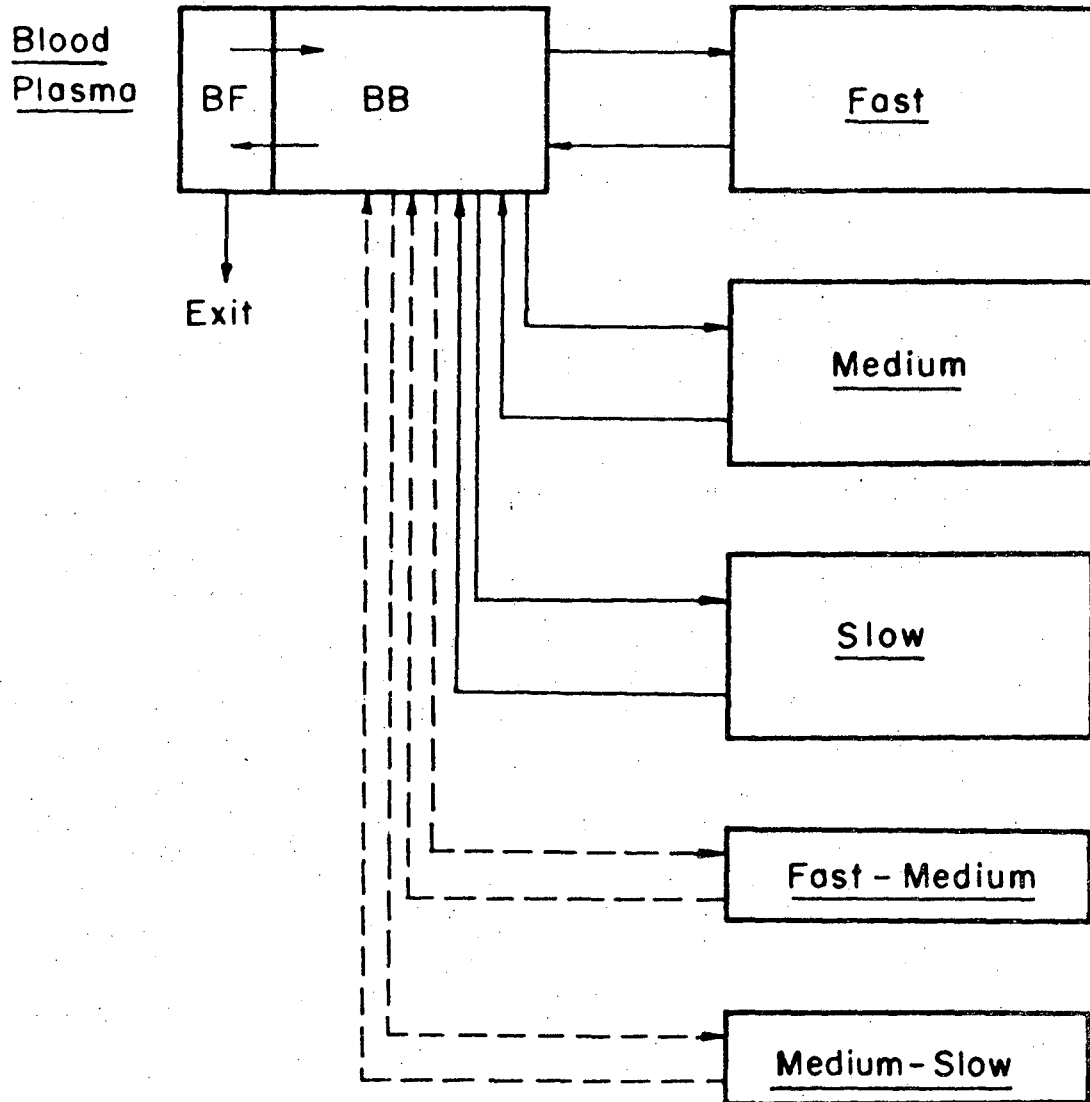

MATHEMATICAL MODEL FOR CHROMIUM (III)

XBL7612-10737

Fig. 18

The slow compartment represents the chromium (III) pool that "stores" chromium(III) primarily in the liver and bones. The highly accurate whole body radiochromium(III) retention and plasma radiochromium(III) clearance data points were then fitted directly to the mathematical model^{47,48,49,50,51,52}.

However one still needs initial estimates for the values of the parameters $k(I)$'s in order to proceed with an iterative convergence to a least square solution. These initial estimates of the parameters were also obtained from experimental results.

B. Computing methods

The computation of the mathematical model is divided into two stages as follow:

- a. Solution of the differential equations, given a set of values of the parameters $k(I)$'s and initial conditions.

For this purpose the "collapse"*

* By collapse is meant the incorporation of one particular compartment with the central compartment to form a single new compartment. This can be justified if the effect or influence of the compartment mentioned first, is assumed negligible, at the time of collapsing, compared to other compartments of the system.

compartment method was used. The computation is divided into several steps. Except for the first step, at each step two or more compartments "collapse" to form a system of a maximum of 3 compartments. Hereby, we reduced the 6 or more compartments of the system to only 3 at each step. Collapsing of one or more artificial compartments to a central compartment was done at times estimated from experimental data. The detailed procedure of the method is described below. First, we introduced and analyzed, the Free-Bound-Fast, three compartment system. As initial conditions, the feedback from the Medium, Slow and other compartments (if any) to the plasma serum bound chromium(III) pool is taken as zero; as mentioned earlier the transfer rates to the Fast, Medium, Slow and other compartment (if any) are assumed to have initial estimated values.

For a general linear steady state 3 compartment system with constant coefficient (fig. 19a) the

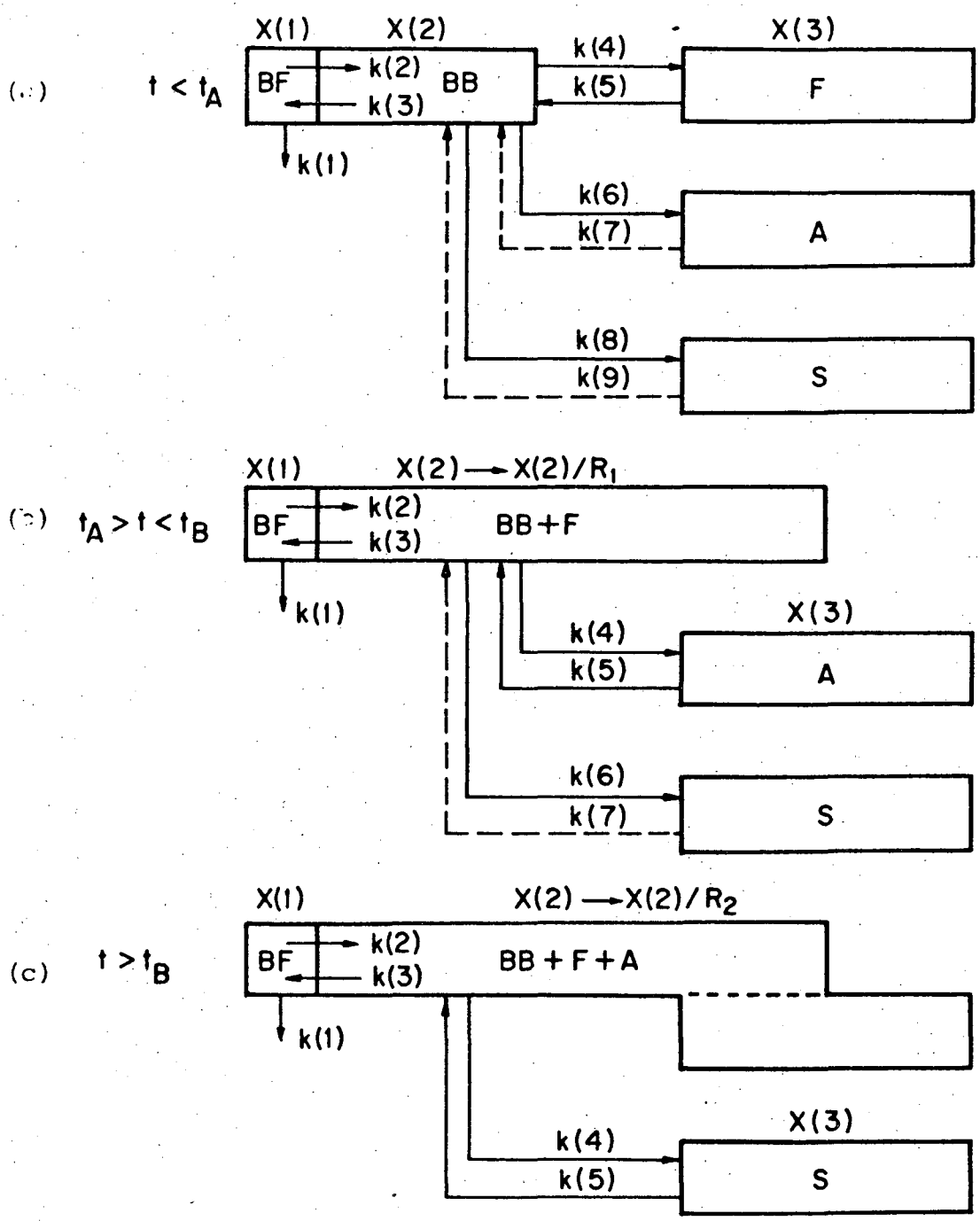

THE "COLLAPSED COMPARTMENT" METHOD MODEL

XBL7612-10736

Fig. 19

Free, Bound and Fast chromium(III) pools as function of time [BF(t), and BB(t) and F(t)] can be calculated from the differential equations:

$$\frac{dX(1)}{dt} = -[k(1) + k(2)]X(1) + k(3)X(2)$$

$$\frac{dX(2)}{dt} = k(2)X(1) - [k(3) + k(4) + k(6)]X(2) + k(5)X(3)$$

$$\frac{dX(3)}{dt} = k(4)X(2) - k(5)X(3)$$

where

X(1) ≡ BF, relative amount of free or unbound chromium(III) in the blood [μg or μCi]

X(2) ≡ BB, relative amount of serum protein bound chromium(III) in the blood [μg or μCi]

X(3) ≡ F, relative amount of chromium(III) in artificial Fast compartment [μg or μCi]

k(I) ≡ transfer rate [day⁻¹]

and k(6) in this equation represents k(6) and k(8) in fig. 19a.

The amount of chromium(III) in the Medium[A(t)] and Slow [S(t)] com-

partments as well as $U(t)$, which is the excretion of free chromium(III) through the kidneys into the urine, are calculated from the linear approximations:

$$A(t) = A_R(t) + k(6) \times UI$$

$$S(t) = S_R(t) + k(8) \times UI$$

$$U(t) = U_R(t) + k(1) \times UI$$

$$\text{where, } k(I)UI = k(I) \int_{t_{j-1}}^{t_j} B(t) dt$$

is a portion of chromium(III) excreted from the blood compartment during the time interval $t_{j-1} - t_j^*$ and A_R, S_R and U_R are estimated values assuming no backflow of the remainder at t_{j-1} and has zero value at the beginning of the experiment. We then modify the $BB(t)$ pool to include the average backflow from each of the Medium and Slow compartment as follows:

$$BB(t) \rightarrow BB(t) + [k(7)(A+A_p)/2 + k(9)(S+S_p)/2] t_a$$

* In this analysis the time interval $|t_{j-1} - t_j| = t_a$ is the period between two successive times of input data.

and $A(t)$ and $S(t)$ become respectively:

$$A(t) \rightarrow A(t) - [k(7)(A+A_p)/2]t_a$$

and

$$S(t) \rightarrow S(t) - [k(9)(S+S_p)/2]t_a$$

where P stands for previous (before backflow). This process is repeated for all values of t up to the "collapse" point t_A .

The next artificial compartmental system to be analyzed is the Free-(Bound + Fast)-Medium system. Here the Fast compartment is incorporated in the Bound chromium(III) compartment to form a new (BB+F) compartment as drawn in fig. 19b. Again, the $BF(t)$, the new $BB(t)$ (to include the Fast compartment) and the $A(t)$ compartment can be calculated from the differential equations:

$$\frac{dX(1)}{dt} = -[k(1)+k(2)]X(1)+k(3)X(2)$$

$$\frac{dX(2)}{dt} = R(1)[k(2)X(1)-[k(3)+k(4)+k(6)]X(2)+k(5)X(3)]$$

$$\frac{dX(3)}{dt} = k(4)X(2)-k(5)X(3)$$

From fig. 19b,

$X(3)$ now represents the Medium (A) compartment

$X(2) = X(2)/R(1)$ represents the combined (BB+F) compartment and

$$R(1) = X(3)/X(2)$$

$X(3)$ represents the slow compartment and $k(4)$ in fig. 19b represents

$k(6)$ in fig. 19a.

$k(6)$ in fig. 19b represents

$k(8)$ in fig. 19a.

$k(5)$ in fig. 19b represents

$k(7)$ in fig. 19a.

Once more, $S(t)$ and $U(t)$ are calculated from the linear approximations:

$$S(t) = S_R(t) + k(8) \times UI$$

$$U(t) = U_R(t) + k(1) \times UI$$

where as before:

$$k(I)UI = k(I) \int_{t_{j-1}}^{t_j} B(t) dt$$

We then again modify $BB(t)$ as follows:

$$BB(t) \rightarrow BB(t) + [k(7) (S + S_p) R(1) / 2] t_a$$

and

$$S(t) \rightarrow S(t) - [k(7) (S + S_p) R(1) / 2] t_a$$

This process is repeated for all values of t between t_A and a new second "collapse" point t_B . Finally to calculate $S(t)$ the same proce-

dure applies.

- b. Data fitting and "adjustment" of parameters.

The whole body radiochromium(III) retention and plasma radiochromium (III) clearance data points were fitted directly to the model. The parameters $k(I)$'s were then "adjusted" to look for the "best" fit of calculated versus experimental data as well as for the functions $BF(t)$, $BB(t)$, $F(t)$, $A(t)$ and $S(t)$.

C. The FOCAL Program MAMC5C

Preliminary analysis using the general "collapsed" method Focal program, suggested that the BF, BB and the F compartment could be collapsed to one compartment after just the first "collapse" point t_A . This simplified and shortened the original program considerably. Also, one "collapse" point, t_A , was sufficient. This program gave acceptable results for both normal subjects and hemochromatosis. The lowest standard deviation of the difference between calculated and experimental data using logarithmic units was approximately 25%. The mathematical model for this modified program is described in

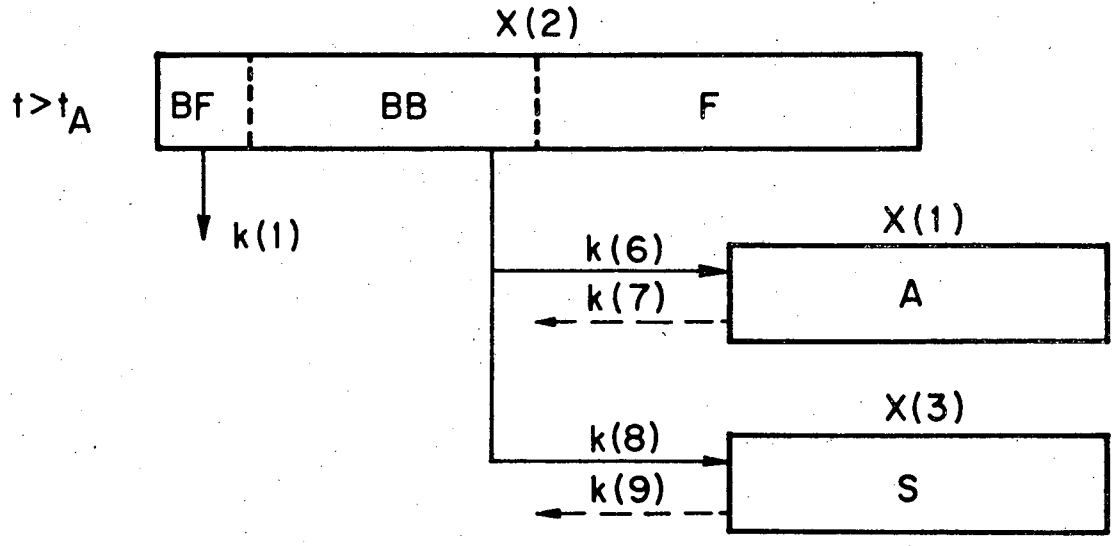
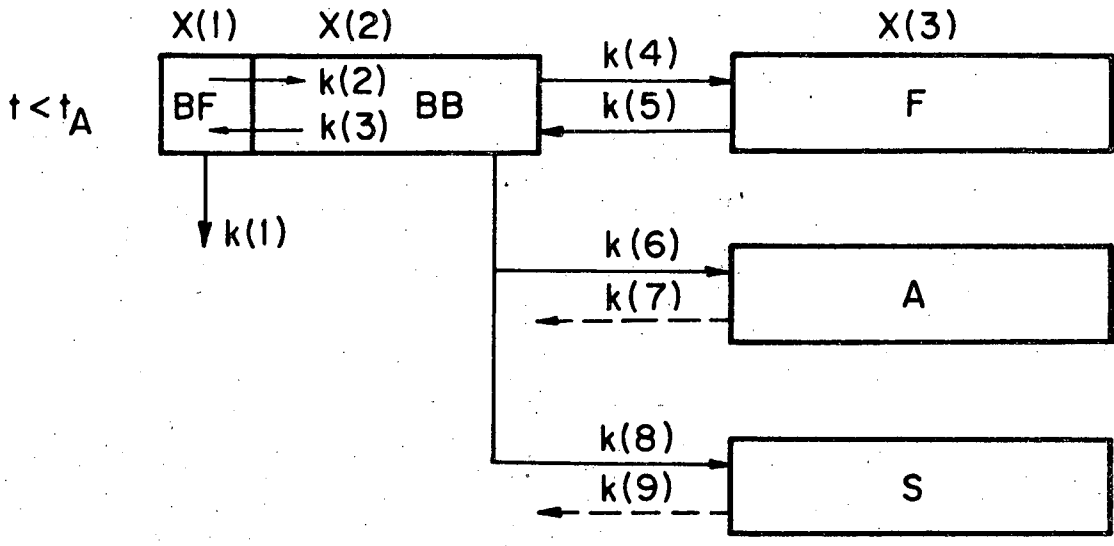

MODEL MAMC5C

XBL7612-10735

Fig. 20

fig. (20). The program is named MAMC5C. Twenty-two data points were provided for the input and the program computed nine parameters.

Results obtained from this program, although acceptable, are not too satisfactory; especially during the first period of the experiment. The errors were rather large. Preliminary results show that the parameter $k(9)$ is not sensitive in controlling the solution. To improve these deficiencies, 26 data points and an additional parameter $k(10)$ were introduced. $k(10)$ represents the release of chromium(III) from the body by some route other than the kidney. The modified program was MMC5CII.

D. The modified MAMC5C program or the Focal program MMC5CII

As was mentioned earlier this program has 26 data points of which the longest time for some subjects goes beyond 100 days.* The addition of 2 data points to the whole body retention input data made $k(9)$ more sensitive. These additions improved the

* Blood radiochromium(III) clearance input data beyond the 50 days period are extrapolated values. For this reason the two last blood radiochromium(III) clearance data points in some subjects were omitted in the calculation.

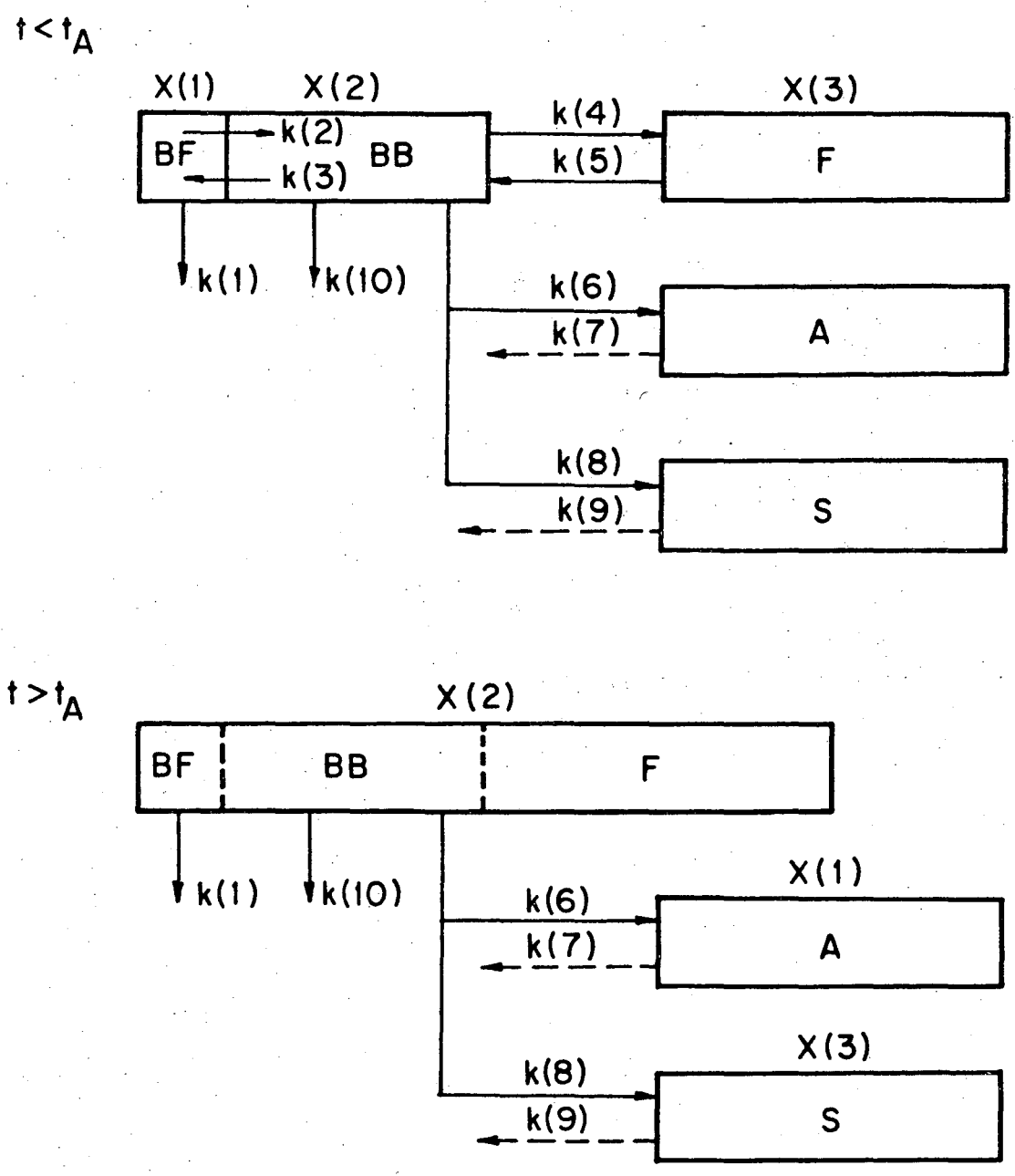

MODEL MMC5C II

XBL7612-10734

Fig. 21

accuracy of the model especially at the early stages (first hours) of the experiment.

Using this program the standard deviation of the difference between calculated and experimental data using logarithmic units, for normals and hemachromatosis averaged around 20%.

Fig. (21) shows the detail of the model both before and after the "collapse" time t_A .

The complete program is listed in Appendix (A).

The calculated parameters of 6 subjects are listed in table (3) and the amount of radiochromium(III) in different hypothetical compartments at various times is listed in tables (4-9).

III. 4. Summary and Discussion

Although only 3 subjects of each category, normals and hemochromatosis, were analyzed in this work, differences in chromium(III) metabolic parameters and patterns between the two groups were found. Except for the first several minutes post-injection, all experimental data was found within acceptable statistical error. The balance error for all the calculation was not to exceed 0.03%.

Inspection and comparison of experimental data, different calculated parameters

CALCULATED RATE-CONSTANTS USING THE FOCAL PROGRAM "MMC5CII"

SUB- JECT*	k(1)**	k(2)**	k(3)**	k(4)**	k(5)**	k(6)**	k(7)**	k(8)**	k(9)**	k(10)**	S.D.***
N#1	5.295	247.3	16.000	77.55	124.5	0.871	0.269	0.1894	0.0021	0.1402	0.2230
N#2	5.206	172.0	8.118	44.28	145.0	0.900	0.356	0.1400	0.0030	0.0845	0.2078
N#3	4.000	238.1	12.180	126.50	303.6	0.716	0.305	0.1707	0.0016	0.0881	0.1841
H#1	28.500	292.0	11.000	123.30	53.3	0.807	0.127	0.3050	0.0034	0.0630	0.1734
H#2	18.840	84.88	4.243	41.60	42.4	2.097	0.368	0.2123	0.0051	0.0651	0.2956
H#3	6.772	243.2	8.810	133.4	399.9	0.774	0.287	0.1497	0.0023	0.0731	0.2257

* For more information concerning the subjects, see Appendix B

** in [day⁻¹]

*** Standard deviation of the differences of calculated and experimental data in logarithmic unit

Table 3

00004606617

CALCULATED ^{51}Cr (III) DISTRIBUTION IN THE FAST, MEDIUM AND SLOW COMPARTMENT
 (% OF TOTAL BODY)--SUBJECT: N#1

T (Days)	F- ^{51}Cr Calc.	T- ^{51}Cr Calc.	T- ^{51}Cr Exp.	Fast Calc.	Medium Calc.	Slow Calc	Excr. Calc.	Excr. Exp.	SD	%BL
0.014	6.5962	67.376	69.50	29.49	0.639	0.139	2.356	2.10	0.2230	0.00
0.027	3.7637	60.789	60.50	34.85	1.298	0.283	2.784	2.40	0.2230	0.00
0.047	3.5315	59.072	57.80	34.83	2.267	0.496	3.332	3.50	0.2230	0.00
0.100	3.3618	57.311	52.70	33.21	4.719	1.040	4.723	4.00	0.2230	0.00
0.324	2.7602	46.209	32.00	27.26	13.52	3.076	9.929	18.00	0.2230	0.00
0.917	1.7087	28.605	13.00	16.88	27.81	6.924	19.78	31.00	0.2230	0.00
3.920	0.4758	7.9647	10.60	4.699	34.09	14.34	38.91	43.0	0.2230	0.00
14.000	0.1625	2.7197	3.380	1.605	12.99	22.33	60.36	56.4	0.2230	0.00
28.000	0.0445	0.7450	0.970	0.440	3.445	25.38	69.99	63.0	0.2230	0.00
36.000	0.0230	0.3848	0.390	0.227	1.705	25.72	71.96	66.0	0.2230	0.00
49.000	0.0101	0.1681	0.140	0.099	0.660	25.61	73.46	70.0	0.2230	0.00
80.000	0.0052	0.0862	0.200	0.051	0.271	24.58	75.01	74.3	0.2230	0.00
135.000	0.0045	0.0759	0.160	0.045	0.233	22.63	77.01	80.0	0.2230	0.00

F- ^{51}Cr : % of free ^{51}Cr in blood plasma; T- ^{51}Cr : total ^{51}Cr in blood plasma (% of total in the body); EXCR: excretion of ^{51}Cr from the body (% of total in the body); SD: Standard Deviation of the differences of calculated and experimental data; %BL: % balance error.

Table 4

CALCULATED ^{51}Cr (III) DISTRIBUTION IN FAST, MEDIUM, AND SLOW COMPARTMENT
 (% OF TOTAL BODY)--SUBJECT: N#2

T (Days)	F- ^{51}Cr Calc.	T- ^{51}Cr Calc.	T- ^{51}Cr Exp.	Fast Calc.	Medium Calc.	Slow Calc.	Excr. Calc.	Excr. Exp.	SD	%BL
0.022	5.0984	75.696	77.60	19.77	1.153	0.180	3.203	2.64	0.2078	0.00
0.045	3.2066	72.109	71.40	21.13	2.582	0.405	3.777	3.60	0.2078	0.00
0.091	3.0297	68.851	65.30	20.22	5.304	0.838	4.782	4.70	0.2078	0.00
0.166	2.8119	64.008	55.00	18.77	9.388	1.503	6.324	8.00	0.2078	0.01
0.356	2.3511	53.518	45.00	15.69	18.02	2.991	9.768	15.4	0.2078	0.01
0.938	1.4547	33.114	30.00	9.710	33.55	6.264	17.36	27.0	0.2078	0.01
1.960	0.8215	18.700	21.60	5.484	41.10	9.595	25.12	34.3	0.2078	0.01
7.000	0.3758	8.5530	10.90	2.508	28.23	17.30	43.41	44.9	0.2078	0.01
15.000	0.1775	4.0394	5.200	1.185	13.26	23.24	58.27	53.4	0.2078	0.01
28.000	0.0563	1.2808	1.700	0.376	4.089	26.40	67.84	62.0	0.2078	0.01
42.000	0.0205	0.4656	0.390	0.137	1.384	26.77	71.24	65.8	0.2078	0.01
84.00	0.0077	0.1743	0.300	0.051	0.429	24.91	74.43	72.1	0.2078	0.01
112.000	0.0071	0.1604	0.200	0.047	0.391	23.53	75.87	75.4	0.2078	0.01

F- ^{51}Cr : % of free ^{51}Cr in blood plasma; T- ^{51}Cr : total ^{51}Cr in blood plasma (% of total in the body); EXCR: excretion of ^{51}Cr from the body (% of total in the body); SD: Standard Deviation of the differences of calculated and experimental data; %BL: % balance error.

Table 5

00004606618

CALCULATED ^{51}Cr (III) DISTRIBUTION IN FAST, MEDIUM, AND SLOW COMPARTMENT
 (% OF TOTAL BODY)--SUBJECT: N#3

T (Days)	F- ^{51}Cr Calc.	T- ^{51}Cr Calc.	T- ^{51}Cr Exp.	Fast Calc.	Medium Calc.	Slow Calc.	Excr. Calc.	Excr. Exp.	SD	%BL
0.004	39.036	88.543	86.90	10.31	0.088	0.021	1.043	0.90	0.1841	0.00
0.045	3.2721	68.096	69.90	27.07	1.966	0.472	2.397	1.80	0.1841	0.00
0.156	2.9969	62.405	59.20	24.81	6.748	1.648	4.394	7.50	0.1841	0.00
0.96	1.6986	35.370	29.80	14.06	27.92	7.801	14.85	23.10	0.1841	0.00
4.00	0.5787	12.050	14.00	4.790	34.94	17.24	30.98	36.30	0.1841	0.00
10.00	0.3041	6.3329	6.800	2.517	20.39	25.47	45.30	44.70	0.1841	0.00
14.00	0.2098	4.3685	4.500	1.736	14.03	78.73	51.13	48.60	0.1841	0.00
21.00	0.1108	2.3073	2.460	0.917	7.350	32.07	57.36	53.40	0.1841	0.00
29.00	0.0550	1.1458	1.360	0.456	3.586	33.81	61.01	55.60	0.1841	0.00
35.00	0.0337	0.7023	0.740	0.279	2.150	34.37	62.50	58.40	0.1841	0.00
49.00	0.0133	0.2771	0.230	0.110	0.773	34.62	64.22	61.60	0.1841	0.00
63.00	0.0079	0.1635	0.210	0.065	0.407	34.34	65.02	65.20	0.1841	0.00
78.00	0.0063	0.1312	0.200	0.052	0.304	33.90	65.62	67.50	0.1841	0.00

F- ^{51}Cr : % of free ^{51}Cr in blood plasma; T- ^{51}Cr : total ^{51}Cr in blood plasma (% of total in the body); EXCR: excretion of ^{51}Cr from the body (% of total in the body); SD: Standard Deviation of the differences of calculated and experimental data; %BL: % balance error.

Table 6

CALCULATED ^{51}Cr (III) DISTRIBUTION IN FAST, MEDIUM, AND SLOW COMPARTMENT
 (% OF TOTAL BODY)--SUBJECT: H#1

T (Days)	F- ^{51}Cr Calc.	T- ^{51}Cr Calc.	T- ^{51}Cr Exp.	Fast Calc.	Medium Calc.	Slow Calc.	Excr. Calc.	Excr. Exp.	SD	%BL
0.0066	13.450	63.407	57.00	28.33	0.214	0.081	7.972	9.00	0.1734	0.00
0.0930	0.8704	26.194	30.80	59.20	2.163	0.822	11.62	11.0	0.1734	0.00
0.1975	0.8146	24.518	21.20	55.40	4.187	1.603	14.29	22.5	0.1734	0.00
1.9200	0.2932	8.8241	7.400	19.94	21.34	9.273	40.63	50.2	0.1734	0.00
2.8340	0.1842	5.5453	5.400	12.53	23.70	11.13	47.09	53.0	0.1734	0.00
8.0	0.0491	1.4762	2.350	3.336	19.50	14.91	60.78	61.0	0.1734	0.00
20.0	0.0199	0.5981	0.700	1.351	8.237	17.58	72.18	69.0	0.1734	0.00
27.0	0.0125	0.3769	0.380	0.852	5.069	18.15	75.56	72.0	0.1734	0.00
34.0	0.0081	0.2446	0.270	0.553	3.148	18.35	77.71	76.1	0.1734	0.00
48.0	0.0039	0.1177	0.110	0.266	1.312	18.19	80.12	76.8	0.1734	0.00
69.0	0.0020	0.0607	0.060	0.137	0.502	17.44	81.86	79.0	0.1734	0.00
94.0	0.0015	0.0454	0.040	0.103	0.304	16.40	83.15	82.6	0.1734	0.00
227.0	0.0010	0.0306	0.010	0.060	0.191	11.64	88.07	89.3	0.1734	0.00

F- ^{51}Cr : % of free ^{51}Cr in blood plasma; T- ^{51}Cr : total ^{51}Cr in blood plasma (% of total in the body); EXCR: excretion of ^{51}Cr from the body (% of total in the body); SD: Standard Deviation of the differences of calculated and experimental data; %BL: % balance error.

Table 7

00004600019

CALCULATED ^{51}Cr (III) DISTRIBUTION IN FAST, MEDIUM AND SLOW COMPARTMENT
 (% OF TOTAL BODY)--SUBJECT: H#2

T (Days)	F- ^{51}Cr Calc.	T- ^{51}Cr Calc.	T- ^{51}Cr Exp.	Fast Calc.	Medium Calc.	Slow Calc.	Excr. Calc.	Excr. Exp.	SD	%BL
0.0154	21.483	67.645	61.10	16.51	1.059	0.108	14.68	7.20	0.2956	0.00
0.036	4.1177	45.881	49.40	32.23	2.977	0.303	18.61	12.1	0.2956	0.00
0.086	1.4741	36.523	37.50	35.32	6.811	0.700	20.65	23.4	0.2956	0.00
0.178	1.2579	31.874	28.00	30.82	12.77	1.336	23.19	31.6	0.2956	0.01
0.383	0.9375	23.971	18.00	22.97	22.80	2.487	27.75	46.3	0.2956	0.03
0.910	0.4988	12.755	11.20	12.22	35.51	4.360	35.12	57.4	0.2956	0.03
1.920	0.2512	6.4237	6.500	6.156	39.07	6.136	42.19	63.9	0.2956	0.03
3.920	0.1703	4.3539	5.400	4.173	32.96	8.144	50.35	68.9	0.2956	0.03
9.10	0.0994	2.5424	2.580	2.437	19.33	11.43	64.24	74.8	0.2956	0.03
23.0	0.0255	0.6507	0.840	0.624	4.820	14.38	79.51	79.1	0.2956	0.03
51.0	0.0040	0.1029	0.110	0.099	0.634	13.81	85.33	83.5	0.2956	0.03
86.0	0.0025	0.0641	0.005	0.062	0.357	12.04	87.45	86.6	0.2956	0.03
149.0	0.0019	0.0491	0.004	0.047	0.272	9.331	90.27	89.7	0.2956	0.03

F- ^{51}Cr : % of free ^{51}Cr in blood plasma; T- ^{51}Cr : Total ^{51}Cr in blood plasma (% of total in the body); EXCR: excretion of ^{51}Cr from the body (% of total in the body); SD: Standard Deviation of the differences of calculated and experimental data; %BL: % balance error.

Table 8

CALCULATED ^{51}Cr (III) DISTRIBUTION IN FAST, MEDIUM, AND SLOW COMPARTMENT
 (% OF TOTAL BODY)--SUBJECT: H#3

T (Days)	F- ^{51}Cr Calc.	T- ^{51}Cr Calc.	T- ^{51}Cr Exp.	Fast Calc.	Medium Calc.	Slow Calc.	Excr. Calc.	Excr. Exp.	SD	%BL
0.00278	50.381	92.275	91.00	6.297	0.053	0.010	1.365	1.00	0.2257	0.00
0.04653	2.418	70.788	72.00	22.860	2.317	0.451	3.583	3.80	0.2257	0.00
0.10625	2.292	67.123	65.00	21.680	5.328	1.046	4.826	6.60	0.2257	0.00
0.17222	2.163	63.341	55.00	20.460	8.412	1.668	6.124	9.70	0.2257	0.00
0.87500	1.231	36.033	31.00	11.640	29.490	6.538	16.310	25.20	0.2257	0.00
2.0	0.639	18.700	22.80	6.039	39.510	10.700	25.050	38.70	0.2257	0.00
7.0	0.269	7.886	11.40	2.547	29.360	18.510	41.700	46.70	0.2257	0.00
14.0	0.147	4.302	5.10	1.389	16.000	24.140	54.170	49.50	0.2257	0.00
21.0	0.082	2.387	2.70	0.771	8.799	27.010	61.030	55.90	0.2257	0.00
28.0	0.046	1.356	1.38	0.438	4.922	28.410	64.870	60.00	0.2257	0.00
36.0	0.026	0.745	0.81	0.241	2.627	29.060	67.320	61.20	0.2257	0.00
49.0	0.012	0.339	0.35	0.109	1.100	29.150	69.300	64.10	0.2257	0.00
64.0	0.007	0.198	0.18	0.064	0.575	28.710	70.450	67.60	0.2257	0.00

F- ^{51}Cr : % of free ^{51}Cr in blood plasma; T- ^{51}Cr : total ^{51}Cr in blood plasma (% of total in the body); EXCR: excretion of ^{51}Cr from the body (% of total in the body); SD: Standard Deviation of the differences of calculated and experimental data; %BL: % balance error.

Table 9

and hypothetical compartments in normal subjects and hemochromatotic patients lead to the following comments:

A. The turnover rate of free chromium(III) in the blood is 3 to 6 times higher in hemochromatosis compared to normals. The fact that the amount of free chromium(III), in vitro as well as in vivo, is also 3 to 6 times higher in hemochromatosis compared to normals, indicates that the transfer rate $k(1)$ is linearly dependent on the amount of free chromium(III). The higher percentage of free chromium(III) in hemochromatotic patients compared to normal subjects can be explained by the fact that the plasma protein transferrin in hemochromatosis is more saturated with iron (>70%) compared to normals, (<50%). This is presumably, because more binding-sites for chromium(III) are available in normals compared to patients suffering from hemochromatosis.

B. The much larger $k(8)$ (absorption in the slow compartment) compared to $k(9)$ (release from the slow compartment) in both normals and hemochromatosis suggest the existence of chromium(III) storage in the hypothetical slow compartment.

C. This model assumed that some chromium (III) in the plasma bound pool is excreted from the body by some route other than the kidney with a rate of $k(10)$. The physiological significance of such excretion is not understood. However, we believe that there may be a relationship between $k(10)$ and the involvement of chromium(III) in cell organelles, so loss of dead cells from the body would result in a loss of chromium(III). This route of loss (approximately 2% of $k(1)$, the loss through the kidney into the urine), is a reasonable non-urinary mechanism to which $k(10)$ may be attributed. For all subjects, $k(10)$ has a rather constant value, compared to $k(1)$, which has much larger values in subjects suffering from hemochromatosis.

D. Further analysis of the liver, spleen and thigh clearance curves*, resulted in the following relative compartment sizes of the Fast, Medium and Slow compartment:

	F.	M.	S.
Liver N#2	30% <u>+27%</u>	23% <u>+27%</u>	47% <u>+27%</u>
Spleen N#2	47% <u>+ 2%</u>	18% <u>+ 2%</u>	35% <u>+ 2%</u>
Thigh N#2	52% <u>+11%</u>	20% <u>+11%</u>	28% <u>+11%</u>
Liver H#1	28% <u>+13%</u>	47% <u>+13%</u>	25% <u>+13%</u>
Spleen H#1	25% <u>+ 1%</u>	22% <u>+ 1%</u>	53% <u>+ 1%</u>
Thigh H#1	39% <u>+10%</u>	36% <u>+10%</u>	25% <u>+10%</u>

Table 10

* in one normal and one patient suffering from hemochromatosis

E. The model assumed that all parameters had constant values during the course of the experiment. However, during the first day post injection further inspection of calculated versus experimental whole body and blood plasma radiochromium(III) clearance data, indicated that a large deviation occurred (up to 40%) every time data was collected after food intake.* The large deviation can probably be associated with the increase in body metabolic activity

* approximately 3 hours post injection

during that time; probably either a variation occurred in the parameters or a nonlinear relation existed that leads to the large difference between calculated and experimental data. This phenomena deserves further investigations by future researchers.

F. The sensitivity to a change of the parameters $k(I)$'s was measured by calculating the resultant fractional change in the standard deviation of the differences of calculated and experimental values in logarithmic unit ($\Delta SD/SD \times 100$) for a 20% increase in each $k(I)$ independently.

The values are listed in table 11. The parameters $k(1)$, $k(2)$ and $k(3)$ were found most sensitive to the change. The most insensitive parameters were $k(5)$ and $k(9)$.

G. It is important to note that subject H#3 is a 38 year old male in the early stages of hemochromatosis*. His plasma, liver, thigh and spleen radiochromium(III) clearance and uptake pattern (fig. 22) as well as the calculated parameters** (tables 3,9) can be

* his brother died of hemochromatosis and his mother has an elevated serum iron.

** calculated from the chromium(III) kinetic model.

Table of $\frac{\Delta SD}{SD} \times 100$

for an increase of 20% in k(I)

	k(1)	k(2)	k(3)	k(4)	k(5)	k(6)	k(7)	k(8)	k(9)	k(10)
N#1	16.6	15.7	11.0	2.8	1.3	5.3	7.7	5.3	1.5	1.7
N#2	17.7	16.1	13.1	2.0	1.9	5.1	6.5	5.3	1.3	2.1
N#3	21.3	18.0	13.7	2.9	0.3	9.1	11.8	11.8	1.8	2.3
H#1	52.1	29.9	54.1	1.0	2.6	0	8.2	7.2	2.0	1.6
H#2	13.0	11.0	9.5	0.7	0.2	2.2	2.2	2.1	0.7	0.1
H#3	14.6	6.7	8.0	0.6	0.6	2.4	3.3	3.3	0	1.2
Average	22.6	16.2	18.2	1.7	1.2	4.0	6.6	5.8	1.2	1.5
	<u>+14.75</u>	<u>+7.85</u>	<u>+17.7</u>	<u>+1.0</u>	<u>+0.96</u>	<u>+3.18</u>	<u>+3.49</u>	<u>+4.54</u>	<u>+0.75</u>	<u>+0.79</u>

Table 11

considered to be within the range of normal subjects. Laboratory tests indeed showed 60% saturation of iron binding capacity (30-50% in normals). Scan-images (fig. 23) did not show any enlargement of the liver, and the concentration of radiochromium(III) in the liver and thigh were found slightly higher than in the average normal. Anterior scan-images of the body did not clearly show the spleen, although the spleen chromium(III) concentration was almost as high as in the average normal (fig. 22). His transfer-rates $k(4)$ and $k(5)$ are higher than in the average normal with a high $k(5)/k(4)$ ratio.

H. At the present time the chromium(III) kinetic model, presented in this work, is the only model which is based on results obtained from experiments with human subjects. As far as we know, it is in fact the first model of chromium(III) metabolism of any form to be proposed, and it is based on in vivo metabolism of a metabolically unperturbed system. It was reported earlier that chromium(III) is important for glucose metabolism in humans. In this context, hopefully in the future, the model will be

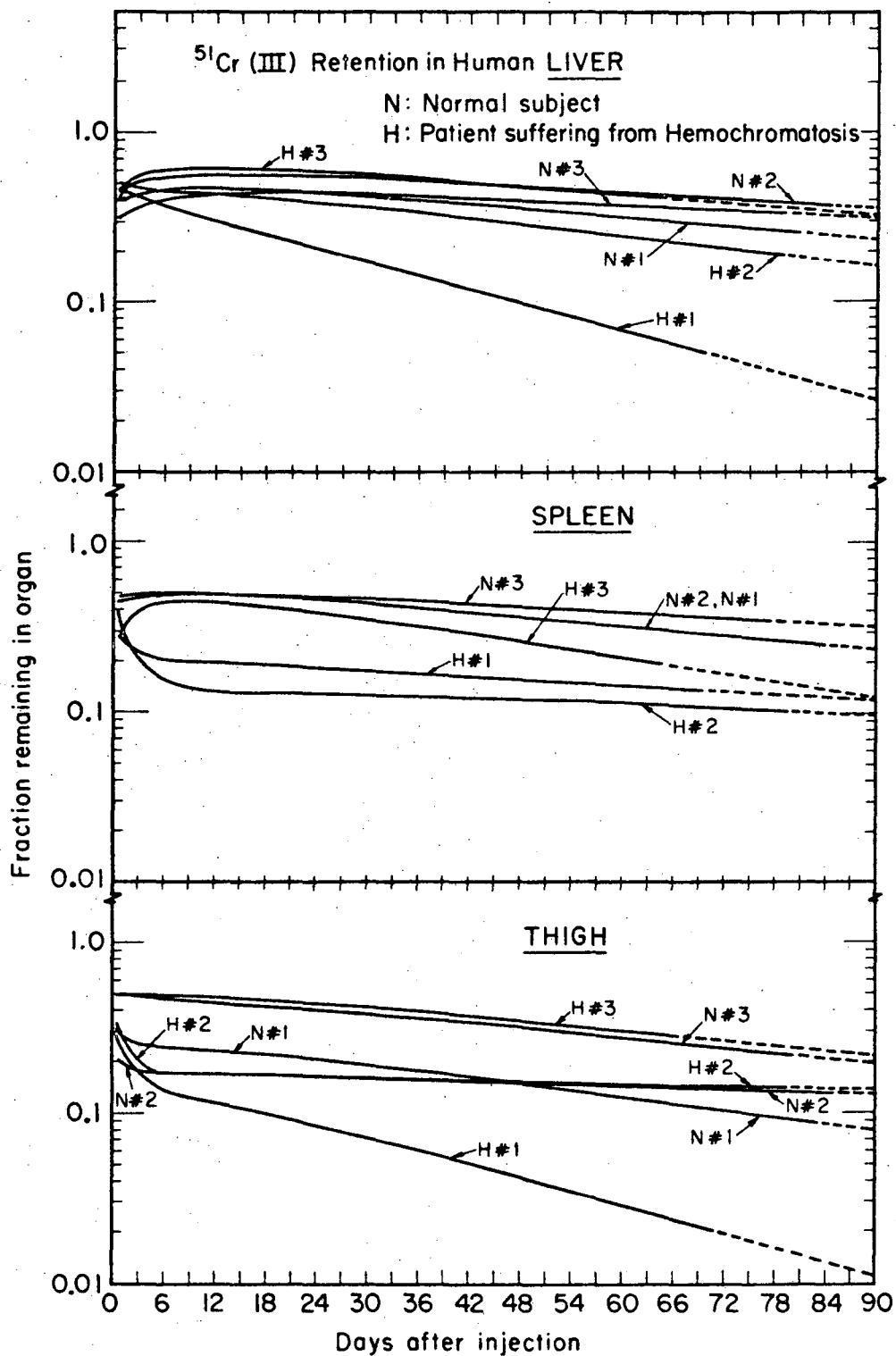
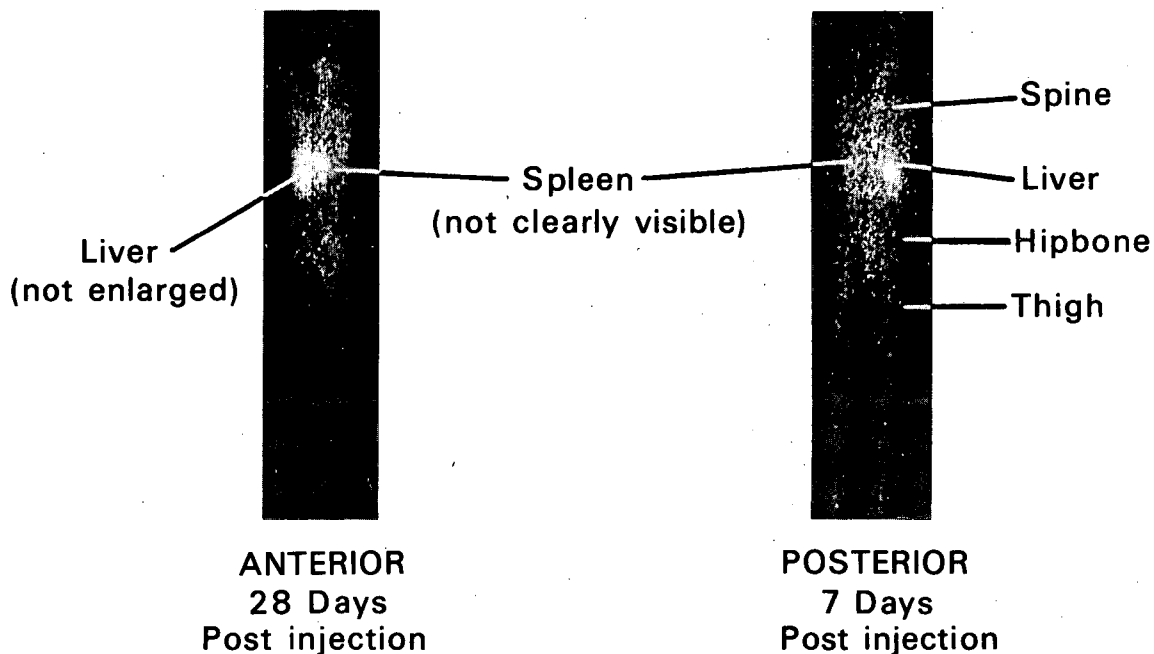

Fig. 22

⁵¹Cr (III) DISTRIBUTION IN DIFFERENT ORGANS



**SUBJECT H #3
EARLY STAGE HEMOCHROMATOSIS**

XBB 771-155

Fig.23

useful in assessing nutritional requirements of chromium(III) in the human diet, and its importance in disease processes such as diabetes.

References

1. Schwarz, K. and Mertz, W., Chromium(III) and the Glucose Tolerance Factor. Arch. Biochem. Biophys. 85:292, 1959.
2. Schroeder, H. H., Chromium Deficiency in Rats: A Syndrome Simulating Diabetes Melitus with Retarded Growth. J. Nutr. 88:439, 1966.
3. Hambidge, K. M., Chromium Nutrition in Man. The American Journal of Clinical Nutrition 27:505, May, 1974.
4. Mertz, W., Roginshi, E. E., and Schwarz, K., Effect of Trivalent Chromium Complexes on Glucose Uptake by Epididymal Fat Tissue of Rats. J. Biol. Chem. 236:318, 1961.
5. Mertz, W., Chromium Occurrence and Function in Biological System. Physiol. Rev. 49:163, 1969.
6. Mertz, W., Human Requirements: Basic and Optimal. Ann. N.Y. Acad. Sc. 191, 1972.
7. Glinsmann, W. H., and Mertz, W., Effect of Trivalent Chromium on Glucose Tolerance. Metab. Clin. Exptl. 15: 510, 1966.
8. Mertz, W., Biological Role of Chromium. Federation Proc. 26:186, 1967.
9. Schroeder, H. A., Balassa, J. J., and Tipton, I. H., Abnormal Trace Metals in Man. J. Chron. Dis. 15:941, 1962.
10. Kuhn, K., and Gerhardt, E., Chemical and Electromicroscopic Studies of the Reaction of Chromium(III) Complexes with Collagen. Z. Naturforsch. 156:23, 1960.
11. Hopkins, L. L., and Schwartz, K., Chromium(III) Binding

- to Serum Proteins, Specifically Siderophilin. *Biochem. Biophys. Actn.*, 90:484, 1964.
12. Horecker, B. L., Stolz, E., and Hogness, T. R., The Promoting Effect of Chromium and the Rare Earths in the Succinic dehydrogenase-cytochrome system. *J. Biol. Chem.* 128:251, 1939.
 13. Stickland, L. H., Activation of Phosphoglucomutase by Metal Ions. *Biochem. J.* 44:190, 1949.
 14. Curran, G. L., Effect of Certain Transition Group Elements on Hepatic Synthesis of Cholesterol in the Rat. *J. Biol. Chem.* 210:765, 1954.
 15. Langenbeck, W., Augustin, M., and Schafer, C., Concerning the Active Metal Ion of Trypsin. *Z. Physiol. Chem.* 324:54, 1961.
 16. Perlman, D., Some Effect of Metallic Ions on the Metabolism of *Aerobacter Acrogenes*. *J. Bacteriol.* 49:167, 1945.
 17. Mertz, W., and Roquislii, E. E., The Effect of Trivalent Chromium on Galactose Entry in Rat Epididymal Fat Tissue. *J. Biol. Chem.* 328:868, 1963.
 18. Wool, I. G., Rampers, O. R., and Moyer, N., Effect of Insulin and Diabetes on Protein Synthesis by Ribosomes from Heart Muscle. *Am. J. Med.* 40:716, 1966.
 19. Campbell, W. J., and Mertz, W., Interaction of Insulin and Chromium(III) on Mitochondrial Swelling. *Am. J. Physiol.* 204:1028, 1963.
 20. Christian, G. D., Knoblock, E. C., Purdy, W. C., and

- Mertz, W., A Polarographic Study of Chromium-insulin-mitochondrial Interaction. *Biochem. Biophys. Actn.* 66:420, 1963.
21. Wachter, W. E. C., and Vallee, B. L., Chromium, Manganese, Nickel and Other Metals in RNA. *Federation Proc.* 18: 345, 1959.
 22. Wacker, W. E. C., and Vallee, B. L., Nucleic Acids and Metals. I. Chromium, Manganese, Metal, Iron and Other Metals in Ribonucleic Acid from Diverse Biological Sources. *J. Biol. Chem.* 234:3257, 1959.
 23. Davidson, I. W. F., and Blackwell, W. L., Changes in Carbohydrate Metabolism of Squirrel Monkeys with Chromium Dietary Supplementation. *Proc. Soc. Explt. Biol. Med.* 127:66, 1968.
 24. Davidson, I. W. F., Lang, C. M. and Blackwell, W. L., Impairment of Carbohydrate Metabolism of the Squirrel Monkey. *Diabetes* 16:395, 1967.
 25. Schroeder, H. A., Serum Cholesterol Levels in Rats Fed Thirteen Trace Elements. *J. Nutr.* 94:475, 1968.
 26. Schroeder, H. A., and Ballassa, J. J., Influence of Chromium, Cadmium, and Lead on Rat Aortic Lipids and Circulating Cholesterol. *Am. J. Physiol.* 209:433, 1965.
 27. Roginski, E. E., and Mertz, W., Dietary Chromium and Amino Acid Incorporation in Rats on a Low-Protein Ration. *Fed. Proc.* 26:301, 1967.
 28. Evans, G. W., Roginski, E. E., and Mertz, W., Inter-

- action of the Glucose Tolerance Factor (GTF) with Insulin. *Biochem. Biophys. Res. Comm.* Vol. 50, No. 3, 1973.
29. Cadinas, E., Kaju, H., Park, C. R., and Rasmussen, H., Inhibition of the Insulin Effect on Sugar Transport by N-ethylmaleimide. *J. Biol. Chem.* 236:63, 1961.
 30. Fong, C. T. O., Silver, L., Popenoe, E. A. and Debons, A. F., Some Observations on Insulin-Receptor Interaction. *Biochem. Biophys. Acta* 56:190, 1962.
 31. Farkas, T. G., Trivalent Chromium and the Crystalline Lens. *Proc. 7th Inter. Congr. Nutrition* 5:705, 1967.
 32. Farkas, T. G., and Roberson, S. L., The Effect of Cr^{3+} on the Glucose Utilization of Isolated Lenses. *Exptl. Eye Res.* 4:124, 1965.
 33. Glinsmann, W. H., and Mertz, W., Effect of Trivalent Chromium on Glucose Tolerance. *Metab. Clin. Exptl.* 15: 510, 1955.
 34. Schroeder, H. A., The Role of Chromium in Mammalian Nutrition. *Am. J. Clin. Nutr.* 21:230, 1968.
 35. Levine, R. A., Streeten, D. H. P., and Doisy, R. J., Effect of Oral Chromium Supplementation on the Glucose Tolerance of Elderly Human Subject. *Metab. Clin. Exptl.* 17:114, 1968.
 36. Hopkins, L. L., and Price, M. G., Effectiveness of Chromium(III) in Improving the Impaired Glucose Tolerance of Middle-Aged Americans. *Proc. Western Hemisphere Nutr. Congr., Puerto Rico, 1968, Vol. II, p. 40.*

37. Hopkins, L. L., and Majaj, A. S., Proc. 7th Intern. Congr. Nutrition, New York, Pergamon, 1967, Vol. 5, p. 721.
38. Hopkins, L. L., Ransome-Kuti, O., and Majaj, A. S., Improvement of Impaired Carbohydrate Metabolism by Chromium(III) in Malnourished Infants. Am. J. Clin. Nutr. 21:203, 1968.
39. Mertz, W., and Roginski, E. E., Effect of Chromium(III) Supplementation on Growth and Survival Under Stress in Rats Fed Low-Protein Diets. J. Nutr. 97:531, 1969.
40. Feldman, F. J., et al., The Determination of Chromium in Biological Materials by Atomic Absorption Spectroscopy. Anal. Chim. Acta. 28:489, 1967.
41. Cann, C. C., Elemental Concentrations and Tracer Uptake Studies in the Parathyroid Glands, Ph.D. Dissertation, Dept. of Nucl. Eng., Univ. of Cal., Berkeley.
42. Desgrez, P., and de Traverse, P. M., Transport Function of Plasma Protein. Elsevier Publishing Co., 1966.
43. Budinger, T. F., Clinical Research Quantitative Nuclear Medicine System. In "Medical Radioisotope Scintigraphy" (1972), p. 501, IAEA, Vienna, 1973.
44. Budinger, Thomas F., Quantitative Nuclear Medicine Imaging: Application of Computers to the Gamma Camera and Whole-Body Scanner, in: Recent Advances in Nuclear Medicine, Vol. 4, edited by John H. Lawrence, Grune and Stratton, New York, London, 1974.
45. Sorenson, James A., Quantitative Measurement of Radio-

- activity in vivo by Whole-Body Counting. Instrumentation in Nuclear Medicine, Vol. 2, Academic Press, 1974, edited by G. J. Hine and J. H. Sorenson.
46. Landahl, H. D., Some Mathematical Aspects of Multi-Compartment Analysis of Tracer Experiments. Annals New York Academy of Sciences, Vol. 108, Art. 1, 1963.
 47. Berman, Monas, and Schoenfeld, Robert, Invariants in Experimental Data on Linear Kinetics and the Formulation of Models. J. Appl. Phys. Vol. 27, No. 11, Nov. 1956.
 48. Berman, Monas, A Postulate to Aid in Model Building. J. Theoret. Biol. 4:229-236, 1963.
 49. Berman, Monas, Weiss, M. F., and Shahn, E., Some Formal Approaches to the Analysis of Kinetic Data in Terms of Linear Compartmental System. Biophys. J. Vol. 2:289-316, 1962.
 50. Berman, Monas, Weiss, M. F., and Shahn, E., The Routine Fitting of Kinetic Data to Models. A Mathematical Formalism for Digital Computers. Biophys. J. Vol. 2:275-287, 1962.
 51. Berman, Monas, The Formulation and Testing of Models. Annals New York Academy of Sciences, Vol. 108, Art. 1, 1963.
 52. Berman, Monas, Compartmental Analysis in Kinetics, in: Computers in Biomedical Research, Vol. II, Academic Press, New York, London, 1965.

APPENDIX A

C-PS/8 FOCAL, 1971

```

01.01 T "MMC5C2: MAMM 5 CMPTS; LA1<<LA2..<<LA5",!
01.09 E
01.30 D 21; D 10.2; D 10.21; T !!
01.40 G 10.1

03.10 S P1=1/(K(1)+K(2)); S TA=1/(K(3)+K(4)); T "T1,T2,T3"
03.20 T 3*P1,3*TA,3/K(5); S TA=5*(P1+TA+1/K(5)); T " TA",TA
03.30 F I=1,NP; D 19
03.40 T " P1",P1,!

05.01 S A=0; S S=0; S U=0; S ST=0; S SS=0; F I=1,3; S X(I)=0
05.05 S II=1; S X(1)=100; S R(1)=0; S R(2)=0
05.10 S K1=K(1); S K2=K(2); S K3=K(3); S K4=K(4); S K5=K(5); S K6=K(6)+K(8)+
05.11 D 14
05.20 F J=1,P1-1; S TI=T(J)-T(J-1); D 6; D 8
05.25 S TI=TA-T(P1-1); D 6
05.30 S R(1)=X(1)/X(2); S R(2)=X(3)/X(2); S X(1)=A; S X(3)=S; S II=2
05.32 S K1=0; S K2=K(7); S K3=K(6); S K4=K(8); S K5=K(9); S K6=K(1)*R(1)
05.33 D 14
05.34 S TI=T(P1)-TA; D 6; D 8
05.35 F J=P1+1,NP; S TI=T(J)-T(J-1); D 6; D 8
05.70 S SS=SS-(FLOG(B/BX(NP)))†2-(FLOG(BL/BX(NP-1)))†2
05.80 S SQ=FSQT(SS/(NP*2-2))
05.85 T %2.00,JJ," L SD",%5.04,SQ,!; R
05.87 T %5.04,"R",R(1)*K(2)/K(3),R(2)*K(5)/K(4),K(7)*X(1)/(K(6)*X(2)),!

06.05 S BL=B
06.10 S A0=A; S S0=S; D 15
06.25 I (II-2) 6.3,6.55,6.55
06.30 S A=A0+K(6)*YI; S CA=K(7)*(A+A0)*TI/(2*A+K(7)*(A0+A)*TI)
06.32 S A=A*(1-CA)
06.35 S S=S0+K(8)*YI; S CS=K(9)*(S+S0)*TI/(2*S+K(9)*(S+S0)*TI)
06.36 S S=S*(1-CS)
06.50 S X(2)=X(2)+(A*CA+S*CS)*R; S B=X(1)+X(2); S U=U+K(1)*XI+K(10)*YI
06.52 S ST=B+X(3)+A+S+U; R
06.55 S B=X(2)*(1+R(1)); S U=U+K(1)*R(1)*YI+K(10)*YI
06.60 S ST=X(2)*(1+R(1)+R(2))+X(1)+X(3)+U

08.02 I (-TY+.2) 8.04,8.2,8.2
08.04 T %3.02,T(J),%5.04
08.06 I (II-2) 8.1,8.15,8.15
08.10 T X(1)," ",B,%4.03,BX(J)," ",X(3),A,S; G 8.17
08.15 T R(1)*X(2)," ",B,%4.03,BX(J)," ",R(2)*X(2),X(1),X(3)
08.17 T " ",U,%3.02,UX(J)," %BAL",100-ST,!
08.20 I (BX(J)-50) 8.3,8.3,8.4
08.30 S SS=SS+(FLOG(B/BX(J)))†2; G 8.5
08.40 S SS=SS+(FLOG((100-B)/(100-BX(J))))†2
08.50 I (UX(J)-50) 8.6,8.6,8.7
08.60 S SS=SS+(FLOG(U/UX(J)))†2; R
08.70 S SS=SS+(FLOG((100-U)/(100-UX(J))))†2

```

```

10.10 S TY=1; D 3; D 5; S SF=SQ; S TY=0
10.15 S Z=1+.2*SF; S RE=FABS(Z-1)/100
10.20 T !"Z",%4.03,Z,!, "K:"; F I=1,7; T K(1)
10.21 T %6.05; F I=8,10; T K(1)
10.23 T !; F JJ=1,PN; D 12
10.30 S JJ=1; D 12; S JJ=10; D 12
10.50 S Z=1+.5*FABS(Z-1)+.1*SF/FSQT(2*NP); S RE=(Z-1)/100
10.60 I (SF-.05) 10.7,10.7,10.8
10.70 T !; D 5; D 10.2; D 9; Q
10.80 S MM=MM+1; T !
10.85 I (MM-3) 10.92,10.9,10.9
10.90 S MM=0; S TY=1; D 10.2; D 10.21; T !!; D 10.1; D 5.87; S QQ=FABS(QQ-SF)
10.91 I (-QQ+.001) 10.92,10.92; T !"G 10.2 OR 10.15 FOR >Z?"; Q
10.92 S QQ=SF; T !"L SD ",SF," "; D 3; D 5; S SF=SQ; G 10.2

12.10 S K(JJ)=Z*K(JJ); D 5; S K(JJ)=K(JJ)/Z
12.20 I (SQ-SF-RE) 12.3,12.6,12.6
12.30 I (SQ-SF) 12.4; R
12.40 I (SQ-SF+RE) 12.5,12.7,12.7
12.50 D 12.7; D 12.1; G 12.3
12.60 S Z=1/Z; D 12.1; G 12.3
12.70 S K(JJ)=K(JJ)*Z; S SF=SQ

14.10 S R=1/(1+R(1)+R(2))
14.30 S PP(1)=K1+K2+K5+R*(K3+K4+K6)
14.35 S PP(2)=K5*(K1+K2)+R*(K1*K3+(K1+K2)*(K4+K6)+K5*(K3+K6))
14.40 S PP(3)=R*K5*(K1*K6+K2*K6+K1*K3)
14.45 S AA(1)=PP(2)-PP(1)+2/3; S AA(2)=2*PP(1)+3/27-PP(1)*PP(2)/3+PP(3)
14.50 I (AA(2)) 14.51,14.52,14.53
14.51 S ZZ=1; G 14.6
14.52 S AA(3)=1.5707965; G 14.8
14.53 S ZZ=-1
14.60 S AA(3)=-6.75*AA(2)+2/AA(1)+3
14.75 S AA(3)=FATN(FSQT(1/AA(3)-1))
14.80 S A(3)=ZZ*2*FSQT(-AA(1)/3); S A(1)=A(3)*FCOS(AA(3)/3)
14.85 S A(2)=A(3)*FCOS(AA(3)/3+2.094395); S A(3)=A(3)*FCOS(AA(3)/3+4.1889
14.90 S A(1)=A(1)-PP(1)/3; S A(2)=A(2)-PP(1)/3; S A(3)=A(3)-PP(1)/3
14.95 I (-A(2)) 14.96; R
14.96 S A(2)=FSQT(PP(1)+2/4-PP(2)); S A(1)=-PP(1)/2-A(2)
14.97 S A(3)=-PP(1)/2+A(2); S A(2)=0

```

15.05 S $XD(1) = -(K1+K2)*X(1)+K3*X(2)$; S $XD(3) = K4*X(2)-K5*X(3)$
 15.10 S $XD(2) = R*(K2*X(1)-(K3+K4+K6)*X(2)+K5*X(3))$
 15.15 S $XS(1) = -(K1+K2)*XD(1)+K3*XD(2)$; S $XS(3) = K4*XD(2)-K5*XD(3)$
 15.20 S $XS(2) = R*(K2*XD(1)-(K3+K4+K6)*XD(2)+K5*XD(3))$
 15.25 S $DN = (A(1)-A(2))*(A(3)-A(1))$; S $DM = (A(1)-A(2))*(A(2)-A(3))$
 15.28 F I=1,3; D 15.85; D 15.9
 15.30 F I=1,3; S $PP(I) = FEXP(A(I)*TI)$
 15.35 I $(-A(1)*TI-100)$ 15.45,15.45,15.36
 15.36 S $PP(1) = 0$
 15.45 S $XI = -A(2)*TI$
 15.46 I $(XI-.001)$ 15.47,15.47,15.48
 15.47 S $XI = AB(1)*TI$; S $YI = AB(2)*TI$; G 15.5
 15.48 S $XI = AB(1)*(PP(2)-1)/A(2)$; S $YI = AB(2)*(PP(2)-1)/A(2)$
 15.50 S $XI = XI + AA(1)*(PP(1)-1)/A(1)$; S $YI = YI + AA(2)*(PP(1)-1)/A(1)$
 15.55 S $XI = XI + (X(1)-AA(1)-AB(1))*(PP(3)-1)/A(3)$
 15.56 S $YI = YI + (X(2)-AA(2)-AB(2))*(PP(3)-1)/A(3)$
 15.60 F I=1,3; S $X(I) = AA(I)*PP(1)+AB(I)*PP(2)+(X(I)-AA(I)-AB(I))*PP(3)$
 15.66 R; T %5.04, T(J),X(1),X(2),X(3),A,S,U,!
 15.67 T "XI",XI,"YI",YI,!; R
 15.85 S $AA(1) = (XD(1)*(A(2)+A(3))-A(2)*A(3)*X(1)-XS(1))/DN$
 15.90 S $AB(1) = (XD(1)*(A(1)+A(3))-A(1)*A(3)*X(1)-XS(1))/DM$

19.10 I $(TA-T(I))$ 19.2; R
 19.20 S $PI = I$; S $I = NP+1$; R

21.01 T "NORM #3",!
 21.10 S $T(1) = .004$; S $T(2) = .045$; S $T(3) = .156$; S $T(4) = .96$; S $T(5) = 4$
 21.11 S $T(6) = 10$; S $T(7) = 14$; S $T(8) = 21$; S $T(9) = 29$; S $T(10) = 35$; S $T(11) = 49$
 21.12 S $K(1) = 3.9173$; S $K(2) = 246.6$; S $K(3) = 13.06$; S $K(4) = 135.6$; S $K(5) = 344.07$
 21.13 S $K(6) = .7675$; S $K(7) = .305$; S $K(8) = .1707$; S $K(9) = .0014$; S $K(10) = .09505$
 21.20 S $BX(1) = 86.9$; S $BX(2) = 69.9$; S $BX(3) = 59.2$; S $BX(4) = 29.8$; S $BX(5) = 14$
 21.30 S $BX(6) = 6.8$; S $BX(7) = 4.5$; S $BX(8) = 2.46$; S $BX(9) = 1.36$; S $BX(10) = .74$
 21.40 S $BX(11) = .23$
 21.50 S $UX(1) = .9$; S $UX(2) = 1.8$; S $UX(3) = 7.5$; S $UX(4) = 23.1$; S $UX(5) = 36.3$
 21.60 S $UX(6) = 44.7$; S $UX(7) = 48.6$; S $UX(8) = 53.4$; S $UX(9) = 55.6$; S $UX(10) = 58.4$
 21.70 S $UX(11) = 61.6$
 21.90 S $NP = 13$; S $PN = 10$
 21.95 S $T(12) = 63$; S $T(13) = 78$; S $BX(12) = .21$; S $BX(13) = .2$
 21.96 S $UX(12) = 65.2$; S $UX(13) = 67.5$

*

*

*3

MMC5C2: MAMM 5 CMPTS; LA1<<LA2...<<LAS
NORM #3

Z 0.000

K: 4.000 238.0 12.18 126.5 303.6 0.716 0.305 0.17070 0.00156 0.08805

T1,T2,T3 0.01240 0.02163 0.00988 TA 0.07319 PI 3.00000

0.01	39.255	88.544	86.90	10.31	0.038	0.021	1.243	0.90	%BAL	0.00
0.05	3.2740	68.090	69.90	27.07	1.966	0.472	2.399	1.30	%BAL	0.00
0.16	2.9985	62.399	59.20	24.31	6.749	1.648	4.096	7.50	%BAL	0.00
0.96	1.6992	35.360	29.80	14.06	27.93	7.820	14.86	23.1	%BAL	0.00
4.00	0.5786	12.040	14.00	4.737	34.95	17.23	30.99	36.3	%BAL	0.00
10.0	0.3041	6.3289	6.800	2.516	20.41	25.45	45.30	44.7	%BAL	0.00
14.0	0.2099	4.3668	4.500	1.736	14.05	28.72	51.13	48.6	%BAL	0.00
21.0	0.1109	2.3074	2.460	0.917	7.361	32.05	57.36	53.4	%BAL	0.00
29.0	0.0551	1.1463	1.360	0.456	3.593	33.79	61.02	55.6	%BAL	0.00
35.0	0.0338	0.7029	0.740	0.280	2.154	34.35	62.51	58.4	%BAL	0.00
49.0	0.0133	0.2774	0.230	0.110	0.775	34.61	64.23	61.6	%BAL	0.00
63.0	0.0079	0.1636	0.210	0.065	0.407	34.33	65.04	65.2	%BAL	0.00
78.0	0.0063	0.1313	0.200	0.052	0.304	33.88	65.63	67.5	%BAL	0.00
0	L SD	0.1768								

Z 1.035

K: 4.000 238.0 12.18 126.5 303.6 0.716 0.305 0.17070 0.00156 0.08805

1	L SD	0.1778
1	L SD	0.1788
2	L SD	0.1786
2	L SD	0.1777
3	L SD	0.1767
4	L SD	0.1766
5	L SD	0.1762
5	L SD	0.1760
6	L SD	0.1750
6	L SD	0.1753
7	L SD	0.1760
7	L SD	0.1758
8	L SD	0.1760
8	L SD	0.1754
9	L SD	0.1754
9	L SD	0.1747
10	L SD	0.1749
1	L SD	0.1771
1	L SD	0.1753
10	L SD	0.1749

L SD 0.1747 T1,T2,T3 0.0124 0.0209 0.0092 TA 0.0709 PI 3.0000
10 L SD 0.1747

Z 1.021

K: 4.000 238.0 12.61 131.0 325.5 0.741 0.305 0.17070 0.00151 0.08805

1 L SD 0.1758
 1 L SD 0.1747
 2 L SD 0.1747
 3 L SD 0.1742
 3 L SD 0.1745
 4 L SD 0.1742
 5 L SD 0.1740
 5 L SD 0.1738
 6 L SD 0.1736
 7 L SD 0.1737
 8 L SD 0.1739
 8 L SD 0.1738
 9 L SD 0.1739
 9 L SD 0.1734
 9 L SD 0.1732
 9 L SD 0.1730
 10 L SD 0.1729
 1 L SD 0.1741
 1 L SD 0.1729
 10 L SD 0.1726
 10 L SD 0.1725

L SD 0.1725 T1,T2,T3 0.0122 0.0205 0.0089 TA 0.0691 P1 3.0000
 10 L SD 0.1725

Z 1.014

K: 3.917 243.0 12.88 133.7 339.3 0.757 0.305 0.17070 0.00142 0.09375

1 L SD 0.1730
 1 L SD 0.1726
 2 L SD 0.1725
 3 L SD 0.1723
 3 L SD 0.1724
 4 L SD 0.1723
 5 L SD 0.1721
 6 L SD 0.1720
 7 L SD 0.1720
 8 L SD 0.1722
 8 L SD 0.1721
 9 L SD 0.1722
 9 L SD 0.1719
 10 L SD 0.1718
 1 L SD 0.1722
 1 L SD 0.1719
 10 L SD 0.1718

N#1

0.02	6.5962	67.376	69.50	29.49	0.639	0.139	2.356	2.10	%BAL	0.00
0.03	3.7637	60.789	60.50	34.85	1.298	0.283	2.784	2.40	%BAL	0.00
0.05	3.5315	59.072	57.80	34.83	2.267	0.496	3.332	3.50	%BAL	0.00
0.10	3.3618	56.311	52.70	33.21	4.719	1.040	4.723	4.00	%BAL	0.00
0.32	2.7602	46.209	32.00	27.26	13.52	3.076	9.929	18.0	%BAL	0.00
0.92	1.7087	28.605	23.00	16.88	27.81	6.924	19.78	31.5	%BAL	0.00
3.92	0.4758	7.9647	10.60	4.699	34.09	14.34	38.91	43.0	%BAL	0.00
14.0	0.1625	2.7197	3.380	1.605	12.99	22.33	60.36	56.4	%BAL	0.00
28.0	0.0445	0.7450	0.970	0.440	3.445	25.38	69.99	63.0	%BAL	0.00
36.0	0.0230	0.3348	0.390	0.227	1.705	25.72	71.96	66.0	%BAL	0.00
49.0	0.0101	0.1681	0.140	0.099	0.660	25.61	73.46	70.0	%BAL	0.00
80.0	0.0052	0.0862	0.200	0.051	0.271	24.58	75.01	74.3	%BAL	0.00
135	0.0045	0.0759	0.160	0.045	0.233	22.63	77.01	80.0	%BAL	0.00

K: 5.295 247.3-16.00 77.55 124.5 0.871 0.269 0.18942 0.00210 0.14017
 1 L SD 0.2144

N#2

K: 5.206 172.0 8.118 44.28 145.0 0.900 0.356 0.14000 0.00297 0.08452

T1, T2, T3	0.01693	0.05725	0.02069	TA	0.15312	PI	4.00000			
0.02	5.0984	75.696	77.60	19.77	1.153	0.180	3.203	2.64	%BAL	0.00
0.05	3.2066	72.109	71.40	21.13	2.582	0.405	3.777	3.60	%BAL	0.00
0.09	3.0297	68.851	65.30	20.22	5.304	0.838	4.782	4.70	%BAL	0.00
0.17	2.8119	64.008	55.00	18.77	9.388	1.503	6.324	8.00	%BAL	0.01
0.36	2.3511	53.513	45.00	15.69	18.02	2.991	9.768	15.4	%BAL	0.01
0.94	1.4547	33.114	30.00	9.710	33.55	6.264	17.36	27.0	%BAL	0.01
1.96	0.8215	18.700	21.60	5.484	41.10	9.595	25.12	34.3	%BAL	0.01
7.00	0.3758	8.5530	10.90	2.508	28.23	17.30	43.41	44.9	%BAL	0.01
15.0	0.1775	4.0394	5.200	1.185	13.26	23.24	58.27	53.4	%BAL	0.01
28.0	0.0563	1.2308	1.700	0.376	4.089	26.40	67.84	62.0	%BAL	0.01
42.0	0.0205	0.4656	0.390	0.137	1.384	26.77	71.24	65.3	%BAL	0.01
84.0	0.0077	0.1743	0.300	0.051	0.429	24.91	74.43	72.1	%BAL	0.01
112	0.0071	0.1604	0.200	0.047	0.391	23.53	75.87	75.4	%BAL	0.01

10 L SD 0.1993

H#1

T1	T2	T3	0.0094	0.0224	0.0563	TA	0.1466	PI	3.0000				
0.01	13.450	63.407	57.00	28.33	0.214	0.081	7.972	9.00	%BAL	0.00			
0.09	0.8704	26.194	30.80	59.20	2.163	0.822	11.62	11.0	%BAL	0.00			
0.20	0.8146	24.518	21.20	55.40	4.187	1.603	14.29	22.5	%BAL	0.00			
1.92	0.2932	3.8241	7.400	19.94	21.34	9.273	40.63	50.2	%BAL	0.00			
2.84	0.1842	5.5453	5.400	12.53	23.70	11.13	47.09	53.0	%BAL	0.00			
8.00	0.0491	1.4762	2.350	3.336	19.50	14.91	60.78	61.0	%BAL	0.00			
20.0	0.0199	0.5981	0.700	1.351	8.237	17.58	72.18	69.0	%BAL	0.00			
27.0	0.0125	0.3769	0.380	0.852	5.069	18.15	75.56	72.0	%BAL	0.00			
34.0	0.0081	0.2446	0.270	0.553	3.148	18.35	77.71	76.1	%BAL	0.00			
48.0	0.0039	0.1177	0.110	0.266	1.312	18.19	80.12	76.8	%BAL	0.00			
69.0	0.0020	0.0607	0.060	0.137	0.502	17.44	81.86	79.0	%BAL	0.00			
94.0	0.0015	0.0454	0.040	0.103	0.304	16.40	83.15	82.6	%BAL	0.00			
227	0.0010	0.0306	0.010	0.069	0.191	11.64	83.07	89.3	%BAL	0.00			
1	K	SD	0.1667										

Z 1.033

K: 28.50 292.0 11.00 123.3 53.34 0.807 0.127 0.33504 0.00336 0.06302

H#2

T1	T2	T3	0.02893	0.06545	0.07073	TA	0.27513	PI	5.00000				
0.02	21.483	67.645	61.10	16.51	1.059	0.103	14.63	7.20	%BAL	0.00			
0.04	4.1177	45.881	49.40	32.23	2.977	0.303	18.61	12.1	%BAL	0.00			
0.09	1.4741	36.523	37.50	35.32	6.811	0.700	23.65	23.4	%BAL	0.00			
0.18	1.2579	31.874	28.00	30.82	12.77	1.336	23.19	31.6	%BAL	0.01			
0.38	0.9375	23.971	18.00	22.97	22.80	2.487	27.75	46.3	%BAL	0.03			
0.91	0.4988	12.755	11.20	12.22	35.51	4.360	35.12	57.4	%BAL	0.03			
1.92	0.2512	6.4237	6.500	6.156	39.07	6.136	42.19	63.9	%BAL	0.03			
3.92	0.1703	4.3539	5.400	4.173	32.96	8.144	50.35	68.9	%BAL	0.03			
9.10	0.0994	2.5424	2.580	2.437	19.33	11.43	64.24	74.8	%BAL	0.03			
23.0	0.0255	0.6507	0.840	0.624	4.820	14.38	79.51	79.1	%BAL	0.03			
51.0	0.0040	0.1029	0.110	0.099	0.634	13.81	85.33	83.5	%BAL	0.03			
86.0	0.0025	0.0641	0.005	0.062	0.357	12.04	87.45	86.6	%BAL	0.03			
149	0.0019	0.0491	0.004	0.047	0.272	9.331	90.27	89.7	%BAL	0.03			
10	L	SD	0.2842										

K: 18.84 84.88 4.243 41.60 42.41 2.097 0.363 0.21232 0.00512 0.06514

H#3

Z 1.009

K: 6.772 243.2 8.810 133.4 399.9 2.774 0.237 0.14972 0.00227 0.07311

T1,T2,T3 0.01200 0.02109 0.00750 TA 0.06766 P1 3.00000

0.00	50.381	92.275	91.00	0.297	2.053	0.010	1.365	1.00	%BAL	0.00
0.05	2.4183	70.788	72.00	22.86	2.317	0.451	3.583	3.80	%BAL	0.00
0.11	2.2924	67.123	65.00	21.68	5.328	1.746	4.826	6.67	%BAL	0.00
0.17	2.1632	63.341	55.00	20.46	8.412	1.663	6.124	9.72	%BAL	0.00
0.88	1.2306	36.033	31.00	11.64	29.49	6.533	16.31	25.2	%BAL	0.00
2.00	0.6336	13.707	22.00	6.039	39.51	10.70	25.05	38.7	%BAL	0.00
7.00	0.2692	7.8363	11.40	2.547	29.36	18.51	41.70	46.7	%BAL	2.00
14.0	0.1469	4.3019	5.100	1.389	16.00	24.14	54.17	49.5	%BAL	0.00
21.0	0.0815	2.3869	2.700	0.771	3.799	27.01	61.03	55.9	%BAL	0.00
28.0	0.0463	1.3558	1.300	0.433	4.922	28.41	64.87	60.0	%BAL	0.00
36.0	0.0255	0.7453	0.810	0.241	2.627	29.06	67.32	61.2	%BAL	0.00
49.0	0.0116	0.3336	0.350	0.109	1.100	29.15	69.00	64.1	%BAL	0.00
64.0	0.0068	0.1979	0.180	0.064	0.575	28.71	70.45	67.6	%BAL	2.00

10 L SD 0.2170

R 0.9762 1.0020 1.1155

L SD 0.2170 T1,T2,T3 0.0120 0.0211 0.0075 TA 0.0677 P1 3.0000

10 L SD 0.2170

Z 1.009

K: 6.772 243.2 8.810 133.4 399.9 2.774 0.237 0.14972 0.00227 0.07311

All SD in this calculation has to be multiplied by 1.08.

INPUT DATA

N#1

21.10 S T(1)=.014; S T(2)=.027; S T(3)=.047; S T(4)=.1; S T(5)=.324
 21.12 S K(1)=5.5; S K(2)=252; S K(3)=16.2; S K(4)=65; S K(5)=125;
 21.13 S K(6)=.85; S K(7)=.23; S K(8)=.18; S K(9)=.004; S K(10)=.17;
 21.20 S T(6)=.917; S T(7)=3.92; S T(8)=14; S T(9)=28; S T(10)=36
 21.30 S T(11)=49
 21.40 S BX(1)=69.5; S BX(2)=60.5; S BX(3)=57.8; S BX(4)=52.7; S BX(5)=32
 21.45 S BX(6)=23; S BX(7)=10.6; S BX(8)=3.38; S BX(9)=.97; S BX(10)=.39
 21.46 S BX(11)=.14
 21.50 S UX(1)=2.1; S UX(2)=2.4; S UX(3)=3.5; S UX(4)=4; S UX(5)=18
 21.55 S UX(6)=31.5; S UX(7)=43; S UX(8)=56.4; S UX(9)=63; S UX(10)=66
 21.56 S UX(11)=70
 21.90 S NP=13; S PN=10
 21.95 S T(12)=80; S T(13)=135; S BX(12)=.2; S BX(13)=.16
 21.96 S UX(12)=74.3; S UX(13)=80;

N#2

21.10 S T(1)=.022; S T(2)=.045; S T(3)=.091; S T(4)=.166; S T(5)=.356
 21.11 S T(6)=.938; S T(7)=1.96; S T(8)=7; S T(9)=15; S T(10)=28
 21.12 S K(1)=5; S K(2)=172; S K(3)=8.8; S K(4)=45; S K(5)=145;
 21.13 S K(6)=.9; S K(7)=.35; S K(8)=.14; S K(9)=.0039; S K(10)=.088;
 21.20 S BX(1)=77.6; S BX(2)=71.4; S BX(3)=65.3; S BX(4)=55; S BX(5)=45
 21.30 S BX(6)=30; S BX(7)=21.6; S BX(8)=10.9; S BX(9)=5.2; S BX(10)=1.7
 21.40 S BX(11)=.23
 21.50 S UX(1)=2.64; S UX(2)=3.6; S UX(3)=4.7; S UX(4)=8; S UX(5)=15.4
 21.60 S UX(6)=27; S UX(7)=34.3; S UX(8)=44.9; S UX(9)=53.4; S UX(10)=62
 21.70 S T(11)=42; S BX(11)=.39; S UX(11)=65.8
 21.90 S NP=13; S PN=10;
 21.95 S T(12)=84; S T(13)=112; S BX(12)=.3; S BX(13)=.2;
 21.96 S UX(12)=72.1; S UX(13)=75.4;

N#3

21.10 S T(1)=.004; S T(2)=.045; S T(3)=.156; S T(4)=.96; S T(5)=4
 21.11 S T(6)=10; S T(7)=14; S T(8)=21; S T(9)=29; S T(10)=35; S T(11)=49
 21.12 S K(1)=4; S K(2)=238; S K(3)=12.18; S K(4)=126.5; S K(5)=323.6
 21.13 S K(6)=.716; S K(7)=.305; S K(8)=.1707; S K(9)=.00156; S K(10)=.08805
 21.20 S BX(1)=86.9; S BX(2)=69.9; S BX(3)=59.2; S BX(4)=29.8; S BX(5)=14
 21.30 S BX(6)=6.8; S BX(7)=4.5; S BX(8)=2.46; S BX(9)=1.36; S BX(10)=.74
 21.40 S BX(11)=.23
 21.50 S UX(1)=.9; S UX(2)=1.8; S UX(3)=7.5; S UX(4)=23.1; S UX(5)=36.3
 21.60 S UX(6)=44.7; S UX(7)=48.6; S UX(8)=53.4; S UX(9)=55.6; S UX(10)=58.4
 21.70 S UX(11)=61.6
 21.90 S NP=13; S PN=10
 21.95 S T(12)=63; S T(13)=78; S BX(12)=.21; S BX(13)=.2;
 21.96 S UX(12)=65.2; S UX(13)=67.5;

N#1

21.10 S T(1)=.0066; S T(2)=.093; S T(3)=.1975; S T(4)=1.92; S T(5)=2.834;
 21.11 S T(6)=8; S T(7)=20; S T(8)=27; S T(9)=34; S T(10)=48;
 21.12 S K(1)=29; S K(2)=292; S K(3)=11; S K(4)=104; S K(5)=50;
 21.13 S K(6)=.95; S K(7)=.1; S K(8)=.27; S K(9)=.003; S K(10)=.1;
 21.20 S BX(1)=57; S BX(2)=30.8; S BX(3)=21.2; S BX(4)=7.4; S BX(5)=5.4
 21.30 S BX(6)=2.35; S BX(7)=.7; S BX(8)=.38; S BX(9)=.27; S BX(10)=.11
 21.40 S BX(11)=.06; S BX(12)=.04; S BX(13)=.01;
 21.50 S UX(1)=9; S UX(2)=11; S UX(3)=22.5; S UX(4)=50.2; S UX(5)=53;
 21.60 S UX(6)=61; S UX(7)=69; S UX(8)=72; S UX(9)=76.1; S UX(10)=76.8;
 21.65 S UX(11)=79; S UX(12)=82.6; S UX(13)=89.3;
 21.70 S T(11)=69; S T(12)=94; S T(13)=227;
 21.90 S NP=13; S PN=10

H#2

21.10 S T(1)=.0154;S T(2)=.036;S T(3)=.086;S T(4)=.178;S T(5)=.383;
 21.11 S T(6)=.91;S T(7)=1.92;S T(8)=3.92;S T(9)=9.1;S T(10)=23;
 21.12 S K(1)=23;S K(2)=90;S K(3)=4;S K(4)=31;S K(5)=40;
 21.13 S K(6)=1.8;S K(7)=.327;S K(8)=.22;S K(9)=.005;S K(10)=.06;
 21.20 S BX(1)=61.1;S BX(2)=49.4;S BX(3)=37.5;S BX(4)=28;S BX(5)=18;
 21.25 S T(1)=.0154;S T(2)=.036;S T(3)=.086;S T(4)=.178;S T(5)=.383;
 21.30 S BX(6)=11.2;S BX(7)=6.5;S BX(8)=5.4;S BX(9)=2.58;S BX(10)=.84;
 21.40 S BX(11)=.11;S BX(12)=.005;S BX(13)=.0038;
 21.50 S UX(1)=7.2;S UX(2)=12.1;S UX(3)=23.4;S UX(4)=31.6;S UX(5)=46.3;
 21.60 S UX(6)=57.4;S UX(7)=63.9;S UX(8)=68.9;S UX(9)=74.8;S UX(10)=79.1;
 21.65 S UX(11)=83.5;S UX(12)=86.6;S UX(13)=89.7;
 21.70 S T(11)=51;S T(12)=86;S T(13)=149;
 21.90 S NP=13;S PN=10;

21.01 T "H #3",!

21.10 S T(1)=.03278;S T(2)=.04653;S T(3)=.10625;S T(4)=.1722;S T(5)=.375
 21.11 S T(6)=2;S T(7)=7;S T(8)=14;S T(9)=21;S T(10)=23;S T(11)=36
 21.12 S K(1)=5;S K(2)=225;S K(3)=12;S K(4)=125;S K(5)=200;
 21.13 S K(6)=.7;S K(7)=.3;S K(8)=.17;S K(9)=.002;S K(10)=.1;
 21.20 S BX(1)=91;S BX(2)=72;S BX(3)=65;S BX(4)=55;S BX(5)=31
 21.30 S BX(6)=22.8;S BX(7)=11.4;S BX(8)=5.1;S BX(9)=2.7;S BX(10)=1.38
 21.40 S BX(11)=.91
 21.50 S UX(1)=.5;S UX(2)=3.8;S UX(3)=6.6;S UX(4)=9.7;S UX(5)=25.2
 21.60 S UX(6)=38.7;S UX(7)=46.7;S UX(8)=49.5;S UX(9)=55.9;S UX(10)=60
 21.70 S UX(11)=61.2
 21.90 S NP=13;S PN=10
 21.95 S T(12)=49;S T(13)=64;S BX(12)=.35;S BX(13)=.19
 21.96 S UX(12)=64.1;S UX(13)=67.6

*

*G -- SENSITIVITY TEST OF K(I)
 MMC5C2: MAMM 5 CMPTS; LA1<<LA2..<<LA5

Z 0.000

K: 28.50 292.0 11.00 123.3 53.34 0.807 0.127 0.30504 0.00336 0.06302

T1,T2,T3 0.00936 0.02234 0.05624 TA 0.14657 PI 3.00000

0 L SD 0.1667

Z 0.167

K: 34.20 292.0 11.00 123.3 53.34 0.807 0.127 0.30504 0.00336 0.06302

1 L SD 0.2535

Z 0.167

K: 28.50 350.4 11.00 123.3 53.34 0.807 0.127 0.30504 0.00336 0.06302

2 L SD 0.2165

Z 0.167

K: 28.50 292.0 13.20 123.3 53.34 0.807 0.127 0.30504 0.00336 0.06302

3 L SD 0.2568

Z 0.167

K: 28.50 292.0 11.00 148.0 53.34 0.807 0.127 0.30504 0.00336 0.06302

4 L SD 0.1684

Z 0.167

K: 28.50 292.0 11.00 123.3 64.01 0.807 0.127 0.30504 0.00336 0.06302

5 L SD 0.1711

Z 0.167

K: 28.50 292.0 11.00 123.3 53.34 0.969 0.127 0.30504 0.00336 0.06302

6 L SD 0.1667

Z 0.167

K: 28.50 292.0 11.00 123.3 53.34 0.807 0.152 0.30504 0.00336 0.06302

7 L SD 0.1803

Z 0.167

K: 28.50 292.0 11.00 123.3 53.34 0.807 0.127 0.36605 0.00336 0.06302

8 L SD 0.1787

Z 0.167

K: 28.50 292.0 11.00 123.3 53.34 0.807 0.127 0.30504 0.00403 0.06302

9 L SD 0.1701

Z 0.167

K: 28.50 292.0 11.00 123.3 53.34 0.807 0.127 0.30504 0.00336 0.07563

10 L SD 0.1694

C-PS/8 FOCAL, 1971

```

01.01 T 1"LEAST SQ; ORGAN CR51, N #2",1
01.09 E
01.20 D 21
01.30 D 22; D 2
01.40 D 23; D 2
01.50 D 24; D 2
01.90 Q

02.10 S RR=0;S MM=0;S SS=0;S RM=0;S RS=0; S MS=0; S RL=0; S ML=0; S SL=0
02.20 F I=1,10; D 3
02.30 D 4; D 5
02.40 S B=NB/DN; S C=NC/DN; S D=ND/DN
02.50 T 1"B,C,D",%6.04,B,C,D,!!; T %5.03
02.60 S SQ=0; S LD=0; F I=1,10; D 7
02.65 S SD=FSQ(SQ/10)
02.70 T 1"L SD",SD,!
02.80 T "AV DQ",LD/10,!!!

03.10 S RR=RR+R(I)+2
03.20 S MM=MM+M(I)+2
03.30 S SS=SS+S(I)+2
03.40 S RM=RM+R(I)*M(I)
03.50 S RS=RS+R(I)*S(I)
03.60 S MS=MS+M(I)*S(I)
03.70 S RL=RL+R(I)*L(I)
03.80 S ML=ML+M(I)*L(I)
03.90 S SL=SL+S(I)*L(I)

04.10 S DN=RR*MM*SS+RM*MS*RS+RS*MS*RM
04.30 S NB=RL*MM*SS+RM*MS*SL+RS*MS*ML
04.50 S NC=RR*ML*SS+RL*MS*RS+RS*SL*RM
04.60 S ND=RR*MM*SL+RM*ML*RS+RL*MS*RM

05.20 S DN=DN-RS*MM*RS-MS*MS*RR-SS*RM*RM
05.40 S NB=NB-SL*MM*RS-MS*MS*RL-SS*RM*ML
05.60 S NC=NC-RS*ML*RS-SL*MS*RR-SS*RL*RM
05.80 S ND=ND-RS*MM*RL-MS*ML*RR-SL*RM*RM

07.05 S LC(I)=B*R(I)+C*M(I)+D*S(I)
07.30 S DQ=FLO G(L(I)/LC(I)); S SQ=SQ+DQ*DQ
07.50 T R(I),M(I),S(I)," ",L(I),LC(I)," ",DQ,I
07.60 S LD=LD+DQ

```

21.10 S R(1)=20; S R(2)=21; S R(3)=20; S R(4)=19; S R(5)=16; S R(6)=9.7
 21.20 S R(7)=5.5; S R(8)=2.5; S R(9)=.38; S R(10)=.05
 21.30 S M(1)=1.2; S M(2)=2.6; S M(3)=5.3; S M(4)=9.4; S M(5)=18
 21.40 S M(6)=34; S M(7)=41; S M(8)=28; S M(9)=4.1; S M(10)=.43
 21.50 S S(1)=.18; S S(2)=.41; S S(3)=.84; S S(4)=1.5; S S(5)=3.0
 21.60 S S(6)=6.3; S S(7)=9.6; S S(8)=17; S S(9)=26; S S(10)=25

22.05 T !"LIVER", !

22.10 S L(1)=.21; S L(2)=.12; S L(3)=.105; S L(4)=.14; S L(5)=.3
 22.20 S L(6)=.3; S L(7)=.31; S L(8)=.33; S L(9)=.31; S L(10)=.24

23.05 T !"SLPEEN", !

23.10 S L(1)=.32; S L(2)=.315; S L(3)=.3; S L(4)=.31; S L(5)=.315
 23.20 S L(6)=.4; S L(7)=.4; S L(8)=.35; S L(9)=.3; S L(10)=.25

24.05 T !"THIGH", !

24.10 S L(1)=.23; S L(2)=.24; S L(3)=.25; S L(4)=.26; S L(5)=.32
 24.20 S L(6)=.30; S L(7)=.28; S L(8)=.25; S L(9)=.22; S L(10)=.12

*00000000000000000000

*

G

LEAST SQ; ORGAN CR51, N #2

LIVER

B, C, D 0.0064 0.0049 0.0103

20.000	1.200	0.180	0.210	0.136	0.433
21.000	2.600	0.410	0.120	0.152	- 0.235
20.000	5.300	0.840	0.105	0.163	- 0.440
19.000	9.400	1.500	0.140	0.184	- 0.271
16.000	18.000	3.000	0.300	0.222	0.302
9.700	34.000	6.300	0.300	0.294	0.021
5.500	41.000	9.600	0.310	0.335	- 0.078
2.500	28.000	17.000	0.330	0.328	0.006
0.380	4.100	26.000	0.310	0.290	0.068
0.050	0.430	25.000	0.240	0.259	- 0.077

L SD 0.249

AV DQ- 0.027

SLPEEN

B, C, D 0.0138 0.0054 0.0102

20.000	1.200	0.180	0.320	0.284	0.121
21.000	2.600	0.410	0.315	0.307	0.025
20.000	5.300	0.840	0.300	0.312	- 0.041
19.000	9.400	1.500	0.310	0.327	- 0.055
16.000	18.000	3.000	0.315	0.348	- 0.098
9.700	34.000	6.300	0.400	0.380	0.050
5.500	41.000	9.600	0.400	0.394	0.016
2.500	28.000	17.000	0.350	0.358	- 0.021
0.380	4.100	26.000	0.300	0.291	0.030
0.050	0.430	25.000	0.250	0.257	- 0.026

L SD 0.059

AV DQ 0.000

THIGH

B, C, D 0.0114 0.0043 0.0061

20.000	1.200	0.180	0.230	0.234	- 0.018
21.000	2.600	0.410	0.240	0.253	- 0.053
20.000	5.300	0.840	0.250	0.256	- 0.024
19.000	9.400	1.500	0.260	0.266	- 0.024
16.000	18.000	3.000	0.320	0.279	0.139
9.700	34.000	6.300	0.300	0.296	0.012
5.500	41.000	9.600	0.280	0.299	- 0.066
2.500	28.000	17.000	0.250	0.254	- 0.015
0.380	4.100	26.000	0.220	0.181	0.194
0.050	0.430	25.000	0.120	0.156	- 0.259

L SD 0.115

AV DQ- 0.011

APPENDIX B
CLINICAL LABORATORY TEST DATA

SUBJ. SEX- AGE	DIAG.	S.I.	% SAT.	SGOT [mU/ml]	GLUCOSE TOLERANCE/INSULIN TESTS [mg/100ml]				GTT**	
					FAST	30 min.	60 min.	120 min.		180 min.
N#1 M-38	Norm.	95	34	38	94/16.5	156/73.2	123/113	95/62.4	65/18.5	Norm.
N#2 M-27	Norm.	96	32	20	91/10.8	120/55.3	112/81.1	120/56.1	85/22.5	Norm.
N#3 M-41	Norm.	118	31	23	80/22.2	167/160.7	172/161.3	151/142.7	122/20.9	Pre- Diab.
H#1 F-31	Hemo- chr.	236	75	22	90/18.9	107/163.5	72/88.7	90/152	93/81.4	Norm.
H#2 F-52	Hemo- chr.	208	79	176	94/8.9	218/62.1	193/57.9	191/86.5	149/43.6	Adult Diab.
H#3 M-38	Early Hemo- chr.	173	60	20	71/6.7	139/69.4	129/97.7	65/19.3	56/78	Norm.

* S.I.: Serum Iron [ug/100ml]

** This comment is based on FAJAN and CONN criteria. Syllabus Twenty-eighth Annual Postgraduate Assembly of the Endocrine Society, held in Seattle, Wash., Oct. 1976, pg. 25.

This report was done with support from the United States Energy Research and Development Administration. Any conclusions or opinions expressed in this report represent solely those of the author(s) and not necessarily those of The Regents of the University of California, the Lawrence Berkeley Laboratory or the United States Energy Research and Development Administration.

TECHNICAL INFORMATION DIVISION
LAWRENCE BERKELEY LABORATORY
UNIVERSITY OF CALIFORNIA
BERKELEY, CALIFORNIA 94720