

Labeling of signals in optical networks and its applications

Krzysztof Borzycki

Abstract—The paper is a review and comparative analysis of most common techniques proposed to attach additional data or identification information to digital signals in optical fiber networks by purely optical means. Such “labels” or “headers” can be attached either to continuous bit streams, e.g., in SDH networks or to optical packets. They enable to monitor, route and identify signals in transparent optical networks, especially those with optical wavelength multiplexing, allow management and supervision of remote optical amplifiers and can be used in optical switching systems. Other applications of this relatively unknown technology include monitoring of optical path dispersion, equalization of channels in DWDM systems and detection of intrusion or jamming in highly secure networks.

Keywords—optical fiber transmission, transparent optical network, pilot tone, network management, overhead data channel, optical fiber dispersion, optical label.

1. Introduction

Advanced transport network must enable management, monitoring, switching and protection of all signals. This functionality depends on transmission of management data associated with specific channels, e.g., for channel origin, destination and content identification.

Synchronous digital hierarchy (SDH) and dense wavelength division multiplexing (DWDM) networks provide dedicated data channels for this purpose, implemented as:

- overhead bytes within SDH frame structure, constituting the data communication channels (DCC);
- bytes inside forward error correction (FEC) overhead added to SDH frame, known as digital wrapper, particularly at STM-64 level;
- separate wavelength reserved for management purposes—the optical supervisory channel (OSC).

Each of these solutions provides transmission capacity of at least 2 Mbit/s.

In packet networks, e.g., gigabit Ethernet (GbE), each packet has header with origin, content and routing data. Routers and other equipment read the header prior to packet handling and processing.

Access to management data associated with transmission channel requires O/E conversion and partial demultiplexing—extraction of DCC bytes, separation of packet header, etc. Electronic circuits performing such tasks must operate at line data rates, e.g., 10.7 Gbit/s or 42.7 Gbit/s. Specific circuitry usually accepts only one data rate and signal structure.

While reliable and standardized [1–3], such solutions are fairly expensive and not compatible with “all-optical network” approach, where costly and bandwidth-limiting O/E and E/O conversions and electronic signal processing are avoided, except for the network edge. The ultimate goal is a “transparent” network, where all signals remain in optical domain. Processing functions: amplification, filtering, 2R/3R regeneration, wavelength conversion, quality monitoring and switching shall be implemented with photonic devices only. Transparent optical network shall be able to handle all kinds of traffic with uniform set of features, like optical switching. Unfortunately, several standards of client signals do not support transmission of associated management data for higher order systems. While the 2R transponders used in DWDM and coarse wavelength division multiplexing (CWDM) equipment handle bit streams of any structure, adding channel associated management data requires an “overlay” solution.

Avoiding electronic signal processing is beneficial in terms of flexibility and future upgrades to higher bit rates or different signal types. Equipment cost, failure rates, size and power consumption are dramatically reduced—there are no repeater cards for all channels, with associated installation and maintenance costs. Unfortunately, access to signal overhead is lost.

Auxiliary data channels are necessary to support functions like:

- 1) network and equipment management;
- 2) order wire and auxiliary data channels;
- 3) identification of signal content, origin and destination;
- 4) connection verification and quality monitoring;
- 5) protection switching.

Functions (1) and (2) implemented in SDH/DWDM and optical cross-connect (OXC) systems require considerable bandwidth, in order of 2 Mbit/s, but can use shared, dedicated wavelength (OSC). Most DWDM systems transmit OSC at 1510 nm, outside standard C and L bands—1528–1565 nm and 1570–1610 nm, respectively [3]. This allows separation of OSC with low-cost optical filters.

Data associated with functions (3)–(5) shall be attached to each single channel in a transport network based on wavelength division multiplexing (WDM) technology. End-to-end optical path may transit several networks, e.g., originating metropolitan area network (MAN)—national core network—destination MAN, each run by different operator

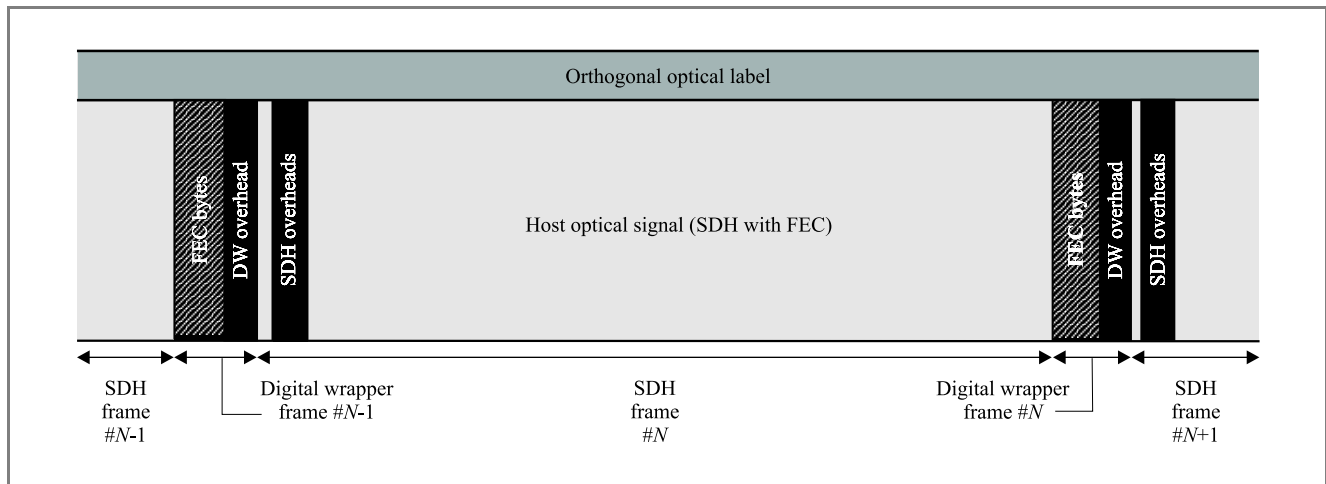

Fig. 1. Overheads provided by optical label, SDH frame and digital wrapper.

with separate management system, and be optically dropped or switched en route. Volume of data transmitted for this purpose is in order of few kbit/s. Capability to add such data to any optical channel regardless of its origin, bit rate and structure is highly desirable.

In a packed-switched network, optical header is always attached to individual data packet and must be read fast in order to avoid delays at optical routers. Otherwise, we need optical buffering of packets with fiber delay lines providing time for header processing, which is expensive and inflexible. Storage of 64-byte and 1024-byte packets at 10 Gbit/s requires approx. 10.5 m and 168 m of single mode fiber, respectively. Fiber sensitivity to bending dictates minimum coil diameter of approx. 50 mm and certain level of mechanical protection. While fiber cost and attenuation are negligible, its splicing and packaging is labor-intensive and expensive. Planar optical waveguides are not suitable for this purpose due to high loss (≈ 100 dB/m) and limited lengths dictated by wafer size.

2. Optical labels

Overhead information associated with optical channel or data packet is known as “optical label”. This is a generic term for variety of modulation and multiplexing techniques developed to attach extra information to host optical signal for many applications (see Section 3).

As signal labels need to be accessed in several locations along signal path, process of label readout should not be demanding in terms of hardware required: optical filters and other components, detector bandwidth, decoder complexity, etc. When network carries mixed traffic with different bit rates, line codes and frame structures, labeling shall be “orthogonal”—independent from payload modulation and coding. Label needs to be read without detection and decoding of host signal, otherwise optical labeling does not offer advantages over SDH overhead or digital wrapper. Adding label to signal does not preclude utilization of

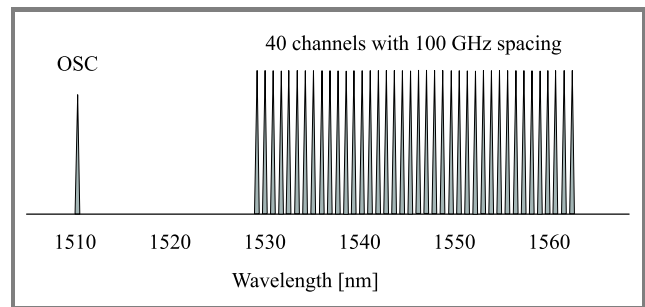

Fig. 2. Typical arrangement of wavelengths in C-band DWDM link.

data channels provided by SDH overhead, digital wrapper, OSC and other means. Figures 1 and 2 provide a comparison.

Figure 1 presents contents of each optical channel (wavelength) indicated in Fig. 2. Size of digital wrapper is smaller than shown in Fig. 1, where exaggeration was needed for clarity. FEC and proper overhead bytes [1] constitute approximately 6.27% and 0.40% of the total data stream, respectively. Most optical labels has bit rates lower than 1/1000th of host signal rate.

Development of optical label technologies is largely stimulated by factors not considered during development of SDH/SONET standards in the 1980s. This includes:

- Development of DWDM, being a dominant transmission technology in core networks today.
- Replacement of electronic signal regeneration with optical amplification.
- Coexistence of different signal formats in transport networks: SDH, synchronous optical network (SONET), GbE, fiber channel, asynchronous transfer mode (ATM), digital video (DV), etc.
- Interconnection of separate networks—preferably by optical means.

- Introduction of optical add-drop multiplexers (OADMs) and optical switching (planned).
- Strong drive to reduce investment and operating costs since 2001.

These conditions reveal limits of SDH—technology providing unparalleled reliability and management features, but developed for networks where signal is fully regenerated at every station, with access to its overhead provided at little extra cost. Many optical transport networks do not use SDH today, especially in the MAN and storage area network (SAN) segment. A need to provide some SDH-like functionality over non-SDH channels exist.

Ideally, optical label should:

- not degrade transmission of host channel, also with optical amplification using erbium doped fiber amplifiers (EDFA), Raman amplifiers or semiconductor optical amplifiers (SOA); acceptable power penalty usually ranges from 0.5 to 2 dB;
- require no modifications to optical components in the network: fibers, amplifiers, filters, etc.;
- be compatible with every type of signal expected in a given network;
- tolerate influence of chromatic dispersion (CD), polarization mode dispersion (PMD), amplifier spontaneous emission (ASE), nonlinear effects, crosstalk, etc., as specified for transmission of host signal, preferably with a power margin of 1–5 dB.

Unfortunately, labels based on subcarrier modulation above payload bandwidth are sensitive to CD and PMD.

Labels with high overhead rates, up to 2.5 Gbit/s on 10 Gbit/s host, tend to introduce significant power penalty and restrict choice of modulation for the host signal, e.g., limit permitted extinction ratio [19]. Such solution is better described as two optically multiplexed channels, jointly designed and optimized.

Certain properties of EDFAs limit choice of label type and parameters:

- amplitude modulation at frequencies below approximately 50 kHz and reuse of frequencies among several WDM channels passing through the same amplifier(s) shall be avoided;
- narrow-band amplitude modulated labels or pilot tones can interfere with EDFA control system;
- nonlinearity of amplifier or fiber, particularly stimulated Raman scattering (SRS) or cross-phase modulation (XPM) may result in transfer of labels between channels.

Labels based on phase modulation and spread spectrum (O-CDMA) techniques are more immune to such phenomena than solutions based on amplitude (intensity) modulation.

A simple label may be formed by specific pattern of unused bits (Section 4.1.5). This pattern creates spectral component in narrow frequency range, picked out by low-cost, narrow-band receiver or is detected by simple pulse sequence correlator implemented with optical delay lines. This technique is akin to frame alignment patterns in digital systems. Improperly selected label patterns may, however, interfere with clock extraction or frame alignment and consequently introduce excessive jitter to host signal.

3. Applications

Known applications for optical signal labels include:

- 1) optical channel management: supervision, identification by origin, destination or content, quality monitoring, etc.;
- 2) non-intrusive monitoring and automatic adjustment of WDM link: channel equalization, counting of active channels, automatic gain control, detection of signal failure;
- 3) optical channel switching: transfer of commands, provision of channel identification data (operator, channel number, etc.), verification of output signal;
- 4) protection switching: detection of signal failure/degrade, verification of output signal;
- 5) provision of extra data channel(s) for network operator;
- 6) packet switching (functions as in packet networks with electronic processing);
- 7) network security: detection of intrusion, unauthorized signal substitution or jamming.

In most cases, signal label serves one or two purposes only.

In general, one may divide applications into:

- 1) related to single channel or packet, used for broadly defined routing and supervision;
- 2) related to operation of network or network element, like optical cross-connect.

Labels of certain type, particularly pilot tones and subcarrier modulation with proper set of frequencies, can be recovered from mix of multiple signals and provide data on their relative power levels. Line signal in this case is tapped from a fiber into single detector and analyzed in frequency domain. This enables supervision and automatic adjustment of DWDM link without optical spectrum analyzer (OSA).

Highly secure networks, e.g., for military, government or banking applications need reliable means to detect optical jamming or insertion of foreign signals instead of legitimate ones. Signal substitution, its processing with inline

electronic device to modify content or injection of powerful jamming signal into optical line amplifier results in erasure of label or significant level deviation. Optical labels, except for modified bit sequences, are removed when signal is regenerated, e.g., when a repeater (without labeling support) is inserted to modify payload or management data. Label absence indicates malicious activity, even when the host signal itself appears unaffected. Labeling scheme for security applications shall remain confidential and be regularly changed to prevent reverse engineering and emulation.

4. Review of labeling techniques

Label technology and content strongly depend on particular application. Label functionality ranges from carriage of simple static message to advanced solutions providing data channel up to 2.5 Gbit/s, enough to support full network management and extra traffic on the same wavelength.

Industry standard have not emerged so far. Several technologies were proposed and discussed within ITU-T Study Group 15 (SG15) since 1997, but remained in unpublished contributions only. ITU-T Recommendation G.709 [1] recognizes the need for optical channel labeling in general, but no specific method is described, recommended or forbidden. Lack of standard prevents commercial introduction despite fairly extensive research work, mostly in Japan, USA, Korea, China and the Netherlands.

Optical labeling is covered by two European Community IST-OPTIMIST projects:

- STOLAS IST-2000-28557: *Switching Technologies for Optically Labeled Signals*. The subject is to develop technologies for very high capacity optical packet switched networks, with: orthogonal optical packet labeling, wavelength conversion, purely optical switching and WDM transport. Labeling methods currently include frequency shift keying (FSK) and differential phase shift keying (DPSK), also with high overhead rates—up to 622 Mbit/s on 10 Gbit/s host channel. The project began in December 2001, with duration of 36 months.
- NEFERTITI IST-2001-32786: *Network of Excellence on Broadband Fiber Radio Techniques and its Integration Technologies*. This project is devoted to development of microwave-frequency optical fiber technologies and equipment, up to 1000 GHz and higher. Optical labeling plays minor role, but microwave frequency subcarrier-modulated labeling and optical channel switching techniques are included. The project began in 2001.

The idea of orthogonal optical labeling is not new. Several line systems belonging to the plesiochronous digital hierarchy (PDH) developed and deployed in the 1980s utilized amplitude modulation of main bit stream to transmit overhead data. Modulation depth and bit rate were not standardized, reaching 1–10% and 2–50 kbit/s, respectively.

Payload and overhead were received by single detector and separated by low/high-pass electrical filters after amplification. Such mechanism was a *de facto* industry standard before 1992, competing with solutions based on digital multiplexing and controlled clock jitter. Digital multiplexing of overhead streams was adopted for SDH/SONET in 1988 and use of analog modulation has stopped.

Labeling methods reported in literature include:

- 1) pilot tones (Section 4.1) usually with amplitude modulation (AM) of host signal (Section 4.1.1);
- 2) low-frequency subcarrier-modulated data channels; modulation methods of the host signal include AM, FSK, and DPSK (Sections 4.1.2 and 4.1.4);
- 3) high frequency subcarrier-modulated data channels (AM), located above spectrum occupied by the host signal (Section 4.1.3);
- 4) optical code division multiplexed (OCDM) data channels—rarely used;
- 5) insertion of label data into fixed locations within frame of host signal (Section 4.1.5);
- 6) header added to data packet; can be at lower bit rate (Section 4.2.1);
- 7) solutions based on wavelength division multiplexing (Section 4.2.2).

Methods (1)–(5) were developed for labeling of continuous bit streams. Methods (6) and (7) are for packet switched networks only; solution (3) is also used. Solution (2) with shallow AM modulation (1–10%) has been included in few ITU-T SG15 contributions since 1997, but never included in any standard.

4.1. Labeling of continuous bit streams

4.1.1. Pilot tones

This the simplest form of labeling: host signal is amplitude-modulated with continuous sine wave of fixed frequency. In a multi-wavelength system, each optical channel is assigned a unique label frequency (Fig. 3). Modulation depth

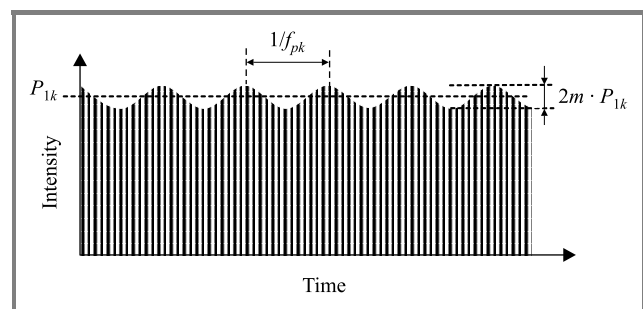

Fig. 3. Amplitude modulation of host digital signal with pilot tone.

is usually limited to 1–5%, keeping resultant power penalty below 0.5 dB and minimizing inter-channel interference during optical amplification.

Label is usually added to host signal at the source, e.g., a transponder inside DWDM terminal. Application of pilot tone to signal in transit, e.g., at switching node is possible by means of optical modulator or amplifier (Section 4.1.1.4).

Labeling is particularly useful for monitoring of WDM networks, where simple and reliable method to identify active channels and measure their relative power levels is needed. Important application for pilot tones is monitoring and equalization of channels in DWDM networks without using costly OSA or DWDM demultiplexer necessary in other methods.

4.1.1.1. DWDM link monitoring: limitations of optical spectrum analysis

As channels sent over WDM link have distinct wavelengths, an obvious and well established solution is to tap small portion of signal, typically 1–3% by means of in-line coupler and use an optical spectrum analyzer to measure spectrum of composite signal. The OSA resolves all channels, measures their wavelengths, relative levels and optical signal to noise ratio (OSNR). Test instrument vendors offer software for automated analysis of WDM spectrum. OSA delivers data for system supervision and adjustment, particularly channel equalization. Unfortunately, fully featured OSAs are expensive, require skilled operators and need periodic calibration. While simplified purpose-built OSA cards for integration with DWDM equipment have appeared, with no moving parts, fixed wavelength range and interface to network management system, hardware cost remains high.

Additionally, optical spectrum analysis cannot establish origin of particular signal or its content. Signal identification needs to be provided by source, e.g., multiplexer. Advances in DWDM technology have reduced channel spacing in installed systems to 0.4 nm (50 GHz); equipment with 0.2 nm (25 GHz) and 0.1 nm (12.5 GHz) spacing is being tested. Typical OSAs have resolution of 0.05–0.10 nm and may not be suitable for testing advanced DWDM networks.

4.1.1.2. Pilot tone principle

Each digital signal in DWDM link is modulated as follows:

$$P_k(t) = P_{1k} \cdot (1 + m_k \sin 2\pi f_{pk} t) \cdot a(t), \quad (1)$$

where: $P_k(t)$ —instantaneous optical power of k th channel; t —time; P_{1k} —average power of k th channel in 1 (ON) state; m_k —modulation index of pilot tone of k th channel; f_{pk} —pilot tone frequency of k th channel; $a(t)$ —waveform of digital stream carrying payload information: $a = 1$ for 1 (ON) state of digital signal. For 0 (OFF) state the value of a is ideally a zero. In real systems, value of a in the 0 state is an inverse of signal extinction ratio, ranging from 0.03 to 0.15.

An example of digital transmitter with labeling function is shown in Fig. 4.

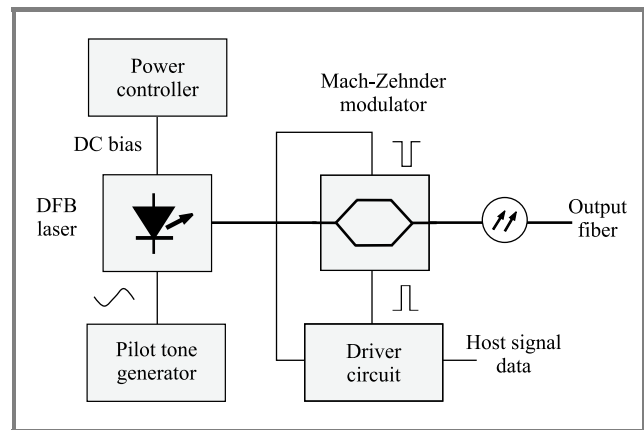

Fig. 4. Transmitter arrangement for adding AM pilot tone.

Monitoring device (Fig. 5) usually comprises optical coupler to tap a small portion, typically about 1% of line signal to narrowband receiver with PIN photodiode, whose output is fed to (electrical) spectrum analysis device. Integrated monitoring modules comprising coupler and InGaAsP photodiode are commercially available.

Following detection by photodiode, amplification and low-pass filtering to remove high-speed digital signal, the resultant voltage for n channels carrying digital signals (NRZ code with 50% mark ratio) is:

$$U(t) = \sum_{k=1}^n R(\lambda_k) \cdot G \cdot T \cdot P_k \cdot m_k \sin 2\pi f_{pk} t, \quad (2)$$

where: $U(t)$ —instantaneous voltage at amplifier output; $R(\lambda_k)$ —photodiode sensitivity at wavelength of k th channel; G —amplifier trans-conductance; T —tap ratio of optical coupler used for line or amplifier monitoring; P_k —average power of k th channel.

Over a narrow wavelength range, e.g., 30 nm (whole C-band or L-band), the sensitivity of InGaAs photodiode is constant within ± 0.05 dB and fixed R value can be assumed without degradation of measurement accuracy. Wider range, e.g., in CWDM link or in C+L band system, necessitates correction using spectral sensitivity table.

Formula (2) allows the following general conclusions:

- monitoring works independently of channel spacing;
- each channel is represented by single frequency component in receiver output;
- accuracy of power monitoring depends on equalized, stable pilot modulation index (m);
- any phenomena changing pilot modulation index degrade monitoring accuracy;
- order of pilot frequencies does not necessarily follow order of optical carriers.

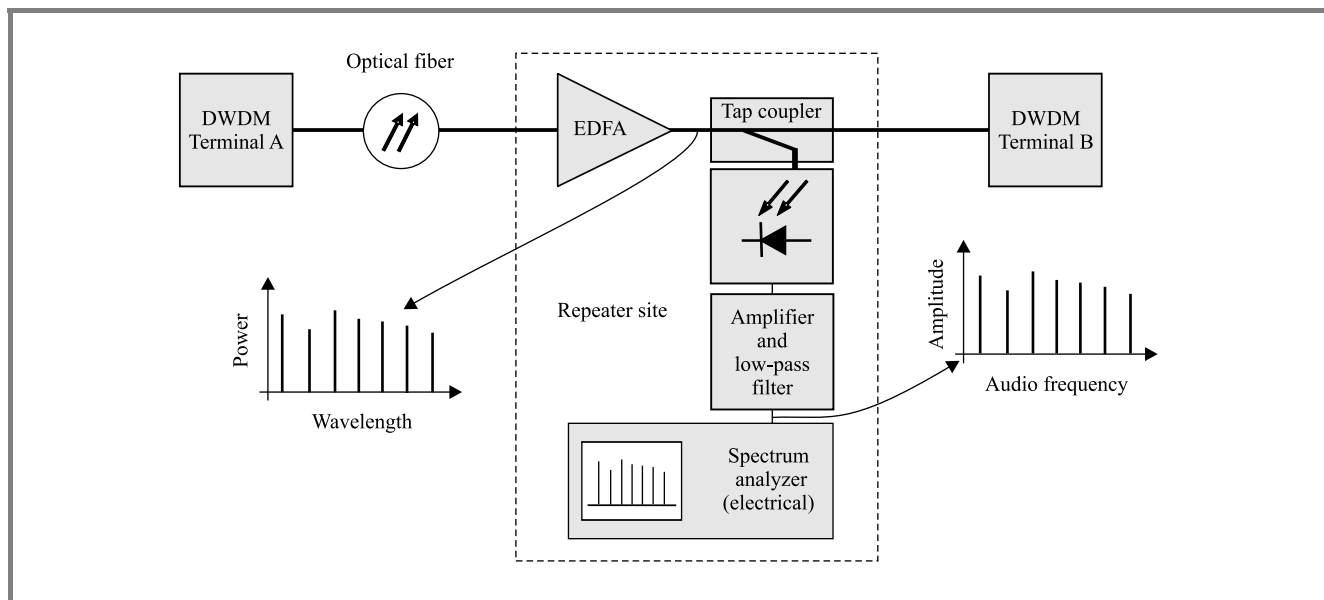

Fig. 5. Pilot tone monitoring in a DWDM link.

Fast Fourier transform (FFT) processing of detected signal yields its spectrum. Peaks correspond to active channels. Measurement data from multiple locations are sent to network management system, being used to adjust channel powers and report system faults.

Selection of pilot frequency is important, because of possible interference with host signal components and the need to minimize negative effects of fiber and amplifier characteristics on pilot tone transmission. In particular, pilot tones shall not coincide with peaks of host signal spectral distribution, to obtain adequate signal-to-noise ratio with limited modulation index.

Choice of label frequencies depends on optical amplifiers used and as type of host signal:

- All telephone-related digital signals (PDH, SONET, SDH) have frames based on 8 kHz sampling, so exhibit peaks of spectral density at multiples of this frequency. Frequencies like 8 kHz, 16 kHz, 24 kHz, etc., shall be avoided to ensure best label to noise ratio. Other standards, like digital TV with 50 Hz field rate and 16.25 kHz line rate (Europe) impose different restrictions in this respect.
- Systems without optical amplifiers: lowest range, typically 0.1–5 kHz. This range ensures best signal-to-noise ratio due to very low spectral density of virtually all host signals, usually NRZ or RZ-modulated. DWDM transponders do not support bit rates below 100 Mbit/s. Frequencies below 100 Hz are avoided due to mains frequency interference and increased density of receiver shot noise.
- Systems with EDFA amplifiers: 50 kHz–1 MHz due to limited lifetime of Er^{3+} ions in excited state [13, 14]. This phenomenon causes attenuation

of signal amplitude components below approx. 50 kHz and increased inter-modulation at low frequencies when signal transits saturated EDFA, resulting in transfer of label (with inverted phase) from one signal to all other passing through the same EDFA. Situation gets worse in long-distance link, as high-pass frequency characteristics and inter-modulation of several EDFAs accumulate. Amplitude-modulated label can also interfere with EDFA power control system, which may interpret low-frequency label as signal power variation and try to compensate for it, resulting in label attenuation and gain instability. Labels above 1 MHz are likely to pass “transparently” through EDFA with any type of power regulation, working both in saturated and unsaturated mode.

- Systems with semiconductor optical amplifiers: modulation index shall be kept low to minimize inter-modulation and undesirable label transfer. These phenomena are fairly independent of label frequency. Considering host signal spectral density, low frequency (≈ 1 kHz) labels are best, provided other factors like noisy power supply do not impose restrictions here.
- Systems with Raman amplifiers: nonlinearity and “competition” for pump power occur in fiber section ≈ 50 km away from pump source, where the pump signal is heavily depleted. Effects on amplitude modulated labels resemble those in SOA. Labels with frequencies below 8 kHz and minimized modulation index should work well.
- Absence of amplifiers gives more freedom, but system designer shall analyze possibility of future upgrades and amplification being added.

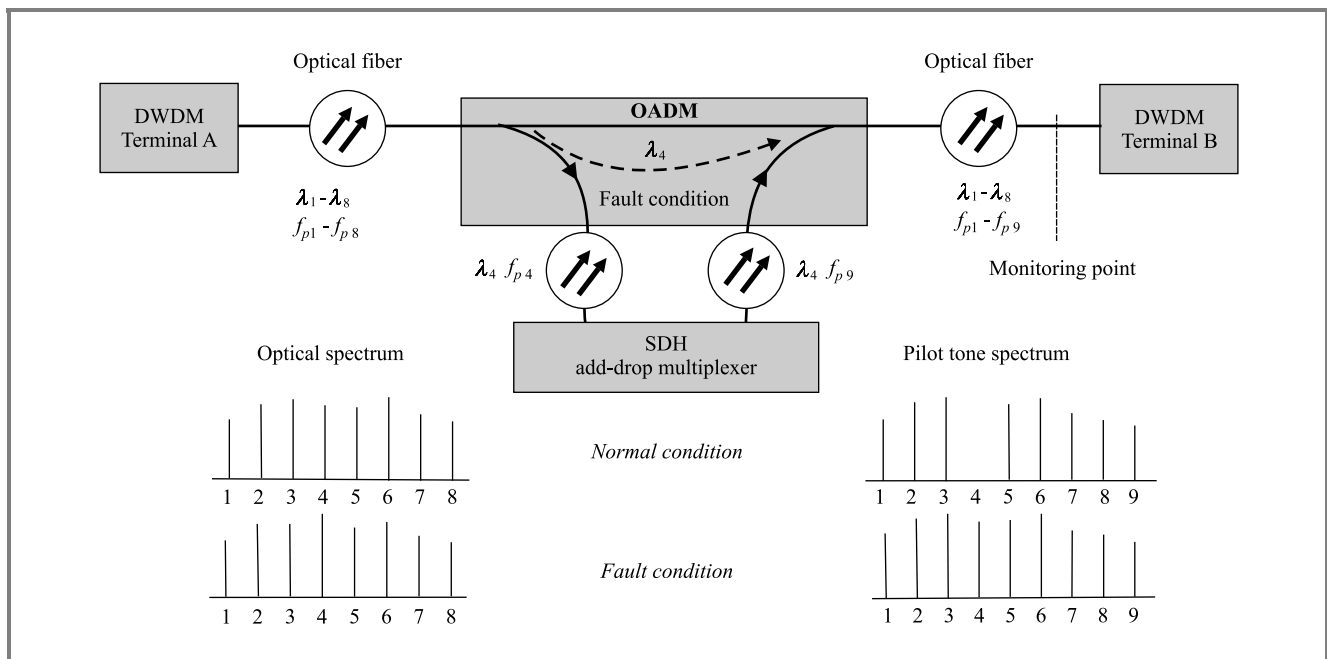

Fig. 6. Collision of two signals at same wavelength and its detection.

- Analog signals, e.g., in optical fiber cable TV networks may require special solutions, utilizing “gaps” in signal spectrum.

Selection of label frequencies is not trivial, because their number in DWDM network may exceed 50. All shall guarantee similar dynamic range of measurements, dictated by signal-to-noise ratio (SNR) and resolution of spectrum analysis system. Most often, a set of equally spaced label frequencies is adopted, e.g., 2.0 kHz, 2.1 kHz ... 5.9 kHz for a 40-channel link. Due to limited finesse (Q) of spectrum analysis devices or filter banks and flat spectral density characteristics of NRZ host signal (SDH, GbE), achievable SNR improves significantly with lower label frequency. Normalized power density of NRZ signal is given by formula:

$$P(f) = \left(\frac{\sin(\pi f / f_{clk})}{\pi f / f_{clk}} \right)^2, \quad (3)$$

where: $P(f)$ —spectral density of signal power, normalized to 1 at $f = 0$; f —frequency; f_{clk} —clock frequency of digital signal (equal to bit rate).

This density is almost constant for frequencies up to $\approx 30\%$ of f_{clk} .

Assuming fixed Q of pilot tone detection system, resulting ratio of received pilot tone to interference from host signal is inversely proportional to pilot tone frequency. With constant bandwidth of pilot tone receiver, it remains constant for all frequencies of interest (10 Hz to 10 MHz), even with 100 Mbit/s host. Interference will be significantly lower in case of host with RZ modulation, often proposed for 40 Gbit/s networks.

The key advantage of pilot tone method is its simplicity and low cost of associated hardware. Functionality is restricted

to monitoring of signal presence and its amplitude. No other information is carried.

4.1.1.3. Limitations of pilot tone method

Pilot tone method has, unfortunately, several limitations and problems:

- does not support transmission of management data;
- wavelength deviations are not detected;
- optical noise or FWM products cannot be measured;
- dynamic range limited to 20–30 dB due to interference from low frequency components of host signal;
- optical amplification can degrade measurement accuracy due to label transfer;
- generation of “ghost tones” due to stimulated Raman scattering (SRS) in long amplified links [9].

Pilot tone monitoring has unique capability to distinguish two or more signals of the same wavelength. This feature is useful for finding faults in optical add-drop multiplexers, networks with wavelength reuse or protection switching devices. Optical spectrum analysis cannot easily detect faults of this nature, as the only indication is increase of signal power, overlooked in system with significant channel level variations (Fig. 6).

Low frequency pilot tones are **immune to effects of chromatic and polarization mode dispersion**.

4.1.1.4. Modulation methods

Amplitude modulation with pilot tone is preferably done at the optical transmitter, transponder or repeater, by adding

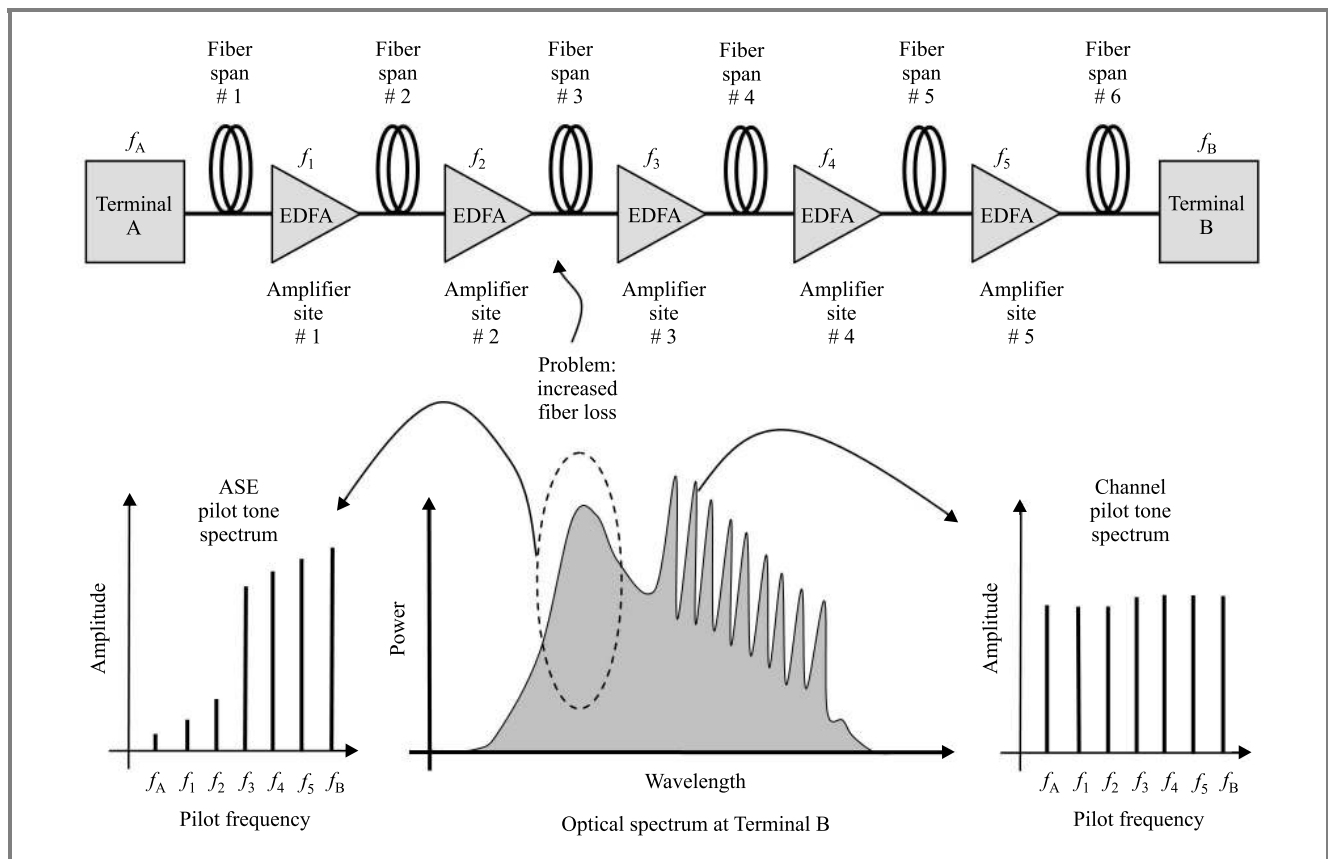

Fig. 7. Labels added at EDFAs in terminals and in-line repeaters enable to locate noisy amplifier span with degraded fiber.

low frequency sine wave to bias or drive current of semiconductor laser (Fig. 4). Alternative methods include passing host signal through:

- optical modulator driven with sine wave of low amplitude;
- semiconductor optical amplifier; sine wave added to DC bias current changes SOA gain;
- EDFA amplifier; sine wave is added to DC bias current of pump laser(s), modulating EDFA gain;
- vibrating reflective component, e.g., mirror in a MEMS switching matrix.

Modulating amplifier gain in WDM line system with pilot tone adds the same label to all signals, so cannot help with their selective identification. However, spurious signals like ASE noise and FWM products are modulated, too. Adding unique pilot tone at each amplifier allows to trace noise contribution of every span (Fig. 7).

Label of this type can be erased, e.g., by passing signal through semiconductor amplifier operating in saturated mode or O/E/O repeater and then replaced with new label if necessary. Re-labeling is of particular interest when signals enter another transport network with separate management system.

Alternatively, pilot tones may be imposed on host signals using phase modulation (PM) or frequency modulation (FM), rather than intensity modulation (AM). Despite advantages like no interference with amplifiers and more flexible selection of label frequencies, this method is less commonly tried, because:

- PM and FM labels require complicated and costly receivers;
- there is no simple method to read multiple labels from mix of several optical signals;
- host signal must exhibit high spectral purity and frequency stability.

However, PM and FM labels are not affected by EDFA dynamics or transferred due to optical nonlinearities, and better choice for optically amplified, non-repeated DWDM links spanning large distances.

4.1.1.5. Receiver power penalty resulting from pilot tone label

Imposing pilot tone or subcarrier-modulated label (Section 4.1.2) by means of amplitude modulation adds noise to 1s of host stream (effects on 0s are negligible) and increases bit error ratio (BER). Power penalty measured as

increase in receiver input power necessary to maintain constant BER depends on modulation index (Fig. 8) and is independent of label frequency, as long as its lower than host clock frequency [13, 15]. Curve shown below is an estimate of upper limit of label penalty; experiments give penalty values up to 50% lower.

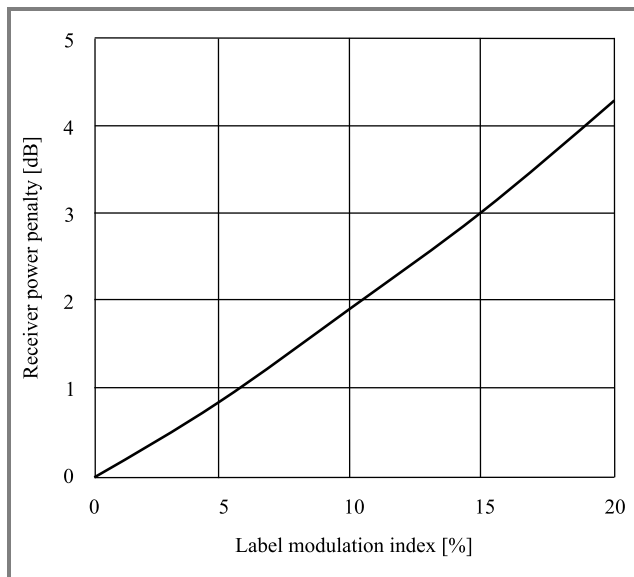

Fig. 8. Estimated label penalty introduced to NRZ receiver at $\text{BER} = 10^{-9}$ [15].

Label penalty is a kind of optical path penalty. The standard requirement for path penalties in SDH networks [4] is 1 dB, dictating modulation index not greater than 7%.

4.1.1.6. Transfer of amplitude-modulated sine-wave labels resulting from stimulated Raman scattering

Dense wavelength division multiplexing transport systems in backbone networks usually comprise several fiber spans, each 70–120 km long and EDFA line amplifiers with output powers between +13 dBm and +24 dBm; total length of unrepeated link often exceeds 500 km. Stimulated Raman scattering occurring primarily in the fiber lengths directly after each EDFA causes cross-modulation of all WDM channels.

In effect, signals are amplitude modulated with new “ghost” label frequencies being products of intermodulation between original set of labels [5, 9]. Amplitude of “ghost” label increases proportionally to system length (number of EDFAs) and signal power; does not noticeably depend on frequency of pilot tones.

The problem is of particular importance when pilot tones are arranged with fixed spacing, as “ghosts” overlap with genuine labels, resulting in false channel identification and power measurement errors.

Investigation by team of Korean researchers [9] led to conclusion, that a DWDM system with 32 channels, +3 dBm channel power, and 100 GHz channel spacing, working on G.652 fiber in C band has a maximum length

of 400 km (5×80 km), if a 10 dB ghost-to-label ratio is to be guaranteed.

Attempts were made to eliminate the problem by adding “saturation” or “control” channel, whose power is quickly adjusted to maintain fixed level of EDFA output; such solutions are already in use in certain commercial systems to maintain desired EDFA gain and spectral characteristics despite changing number of active channels. The solution is effective in a single span. In a multi-span system, however, uneven spectral gain of EDFAs and adding/dropping of channels results in loss of balance and appearance of “ghosts”—unless each amplifier site is equipped with its own saturation channel controller, which is expensive.

4.1.2. Low frequency subcarrier-modulated label with data channel

This method is an extension of pilot tone label. Carrier wave of relatively low frequency (10 kHz–10 MHz) (see Fig. 9) is modulated with data using ASK, FSK or DPSK modulation, then superimposed on host signal by modulating its amplitude (AM/ASK), phase (PM/PSK/QPSK) or frequency (FM/FSK). Data rates are limited to 1–150 kbit/s, as the label is located within region of high spectral density of the host. STM-256 (40 Gbit/s) signals are expected to be RZ-coded, so reduced spectral density at low frequencies will allow for higher label rates. All modulation methods and transmitter design (Fig. 4) presented in Section 4.1 are applicable to subcarrier-modulated (SCM) labels as well.

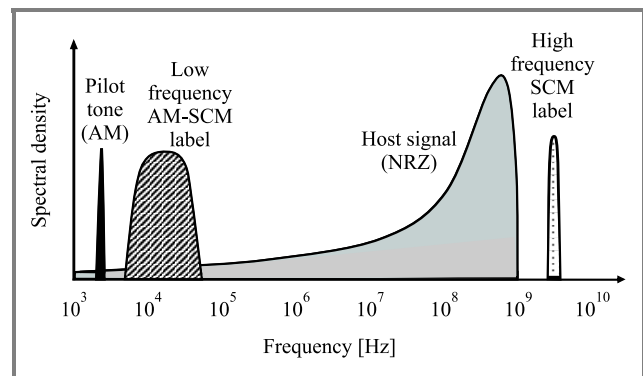

Fig. 9. Label signals with respect to spectrum of STM-16 host (density per octave shown). Only one label option is usually implemented.

Main advantages of this labeling method include:

- low-speed and inexpensive electronics for label processing;
- immunity to effects of fiber dispersion;
- for AM or ASK modulation: little or no changes to optical receivers.

For a given host structure and line code (e.g., STM-1/4/16/64—NRZ), available label bit rate grows with host

signal rate and allowable power penalty to host signal resulting from eye closure. The latter is preferably kept below 1 dB. For NRZ modulated SDH host and DPSK modulation, overhead bit rate is limited to $1-2 \cdot 10^{-5}$ of host rate. In a “transparent” system adding and reading labels in transit, label capacity must be suited to least supportive host type.

Ability to transmit user information makes this method versatile and suitable for complex networks. SCM labels can convey information like:

- channel identification: source, destination, content, protection priority, encryption, etc.;
- physical channel characteristics: wavelength, bit rate, use of FEC, etc.;
- management data: alarms, telemetry, protection switching commands, housekeeping, etc.;
- operator data associated with given channel;
- extra payload channel(s).

Communication with amplifier sites is also possible: modulation of EDFA or SOA gain allows to apply a new label and transmit overhead information [13] without adding dedicated service channel transponders and associated optical couplers. This solution was proposed for telemetry and remote control in long-distance submarine and terrestrial systems, including transoceanic links with up to 300 EDFA amplifiers. Unfortunately, large variety of solutions proposed makes adoption of common standard unlikely.

Choice of operating frequency with AM modulation is restricted exactly as for pilot tones. Because of wider bandwidth occupied and therefore lower signal to noise ratio compared to unmodulated pilot tones, AM labels of this kind are generally unsuitable for signal power monitoring.

Application of label by frequency or phase keying (FSK/QPSK) of host signal avoids interference with optical amplifiers. Label modulation is accomplished by external Mach-Zehnder interferometer driven with signals of opposite phase. Another method is to modulate laser drive current, which results in changes of both intensity and frequency of emitted light. If the signal subsequently passes through a booster amplifier operating in saturation mode, unwanted amplitude modulation is suppressed.

Such label is “invisible” to ordinary intensity detectors, and must be detected by separate optical subsystem (e.g., interferometric), adding to equipment cost and complexity.

4.1.3. High frequency subcarrier-modulated data channel

Location of label above band occupied by the host signal (Figs. 9 and 10) has several advantages:

- labeled signals pass through multiple EDFAs without attenuation of labels;
- labels cause no interference to power controllers of EDFA amplifiers;

- fewer problems with label transfer caused by fiber or amplifier nonlinearity;
- possibility of dispersion monitoring in certain labeling schemes;
- very high label bit rates are possible.

With proper frequency separation, label-host interference is eliminated and label data rate may easily exceed 10% of host rate. Very high overhead capacity is possible, but reduces host power budget accordingly, as signal power is divided between two frequency multiplexed components: the host and the label. AM label can be separated from host signal by means of simple band-pass electrical filter in the receiver.

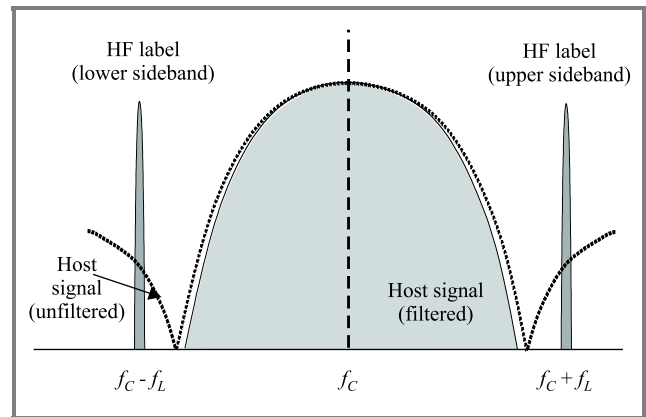

Fig. 10. Optical spectrum of host signal with high frequency SCM label (horizontal axis: optical frequency). Explanations: f_c —host carrier frequency; f_L —label frequency.

This solution has its problems, namely:

- label is more sensitive to fiber dispersion (CD, PMD) than host signal; dispersion induced fading can even erase the label completely (see Section 4.1.3.1);
- wideband, more expensive (and non-standard) receiver is needed;
- AM label modulation often requires use of external optical modulator instead of simpler direct modulation by changing the bias current of transmit or pump laser;
- monitoring scheme shown in Fig. 5 cannot be implemented.

Host receiver does not need modification, as long as its bandwidth is tailored to given host signal rate, which ensures attenuation of label before decision circuit. Use of “transparent” 2R transponders operating below specified maximum bit rate, e.g., receiving 1.25 Gbit/s GbE stream instead of 2.5 Gbit/s or 2.7 Gbit/s (STM-16/OC-48) violates this condition and may result in considerable power penalty or appearance of error floor.

With large frequency separation between host and label, one may apply optical filtering, e.g., removing host signal with matched fiber Bragg grating (FBG) filter (Fig. 11). This technique is expensive due to need for matched filter for each channel, but allows to use narrow-band, low-cost receiver for the label.

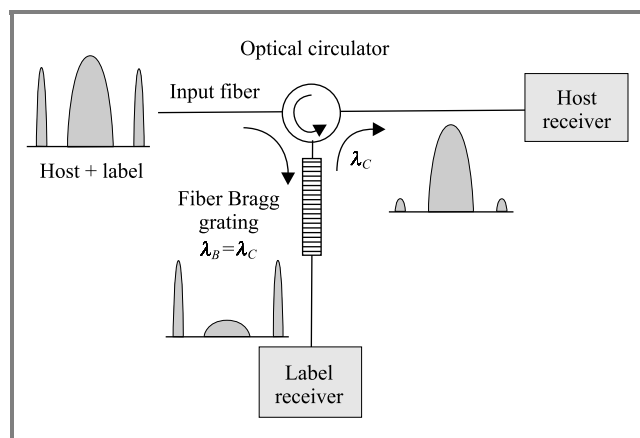

Fig. 11. Separation of host and high frequency label using optical filter [28].

Separation of label by filtering requires that overlap of host and label spectra be minimized. As the label occupies less bandwidth and carries less energy than host, the main issues when labeling NRZ-coded signal are:

- Removal of host components lying above clock frequency before modulation of optical carrier (see Fig. 10). A low-pass filter with 3 dB bandwidth equal to about 0.8 of clock frequency and linear modulator are necessary to support subcarrier-modulated label, while still meeting optical waveform specifications and avoiding noticeable power penalty. Pilot-tone solutions are considerably more tolerant, as label receiver bandwidth can be in principle be made as narrow as necessary, reducing host crosstalk accordingly.
- Selection of label frequency. Location of high bit rate label, carrying a considerable fraction of total signal power, e.g., 5% or 10% sets a rigid limit to symbol rate of host signal.
- Limiting extinction ratio of host signal. Certain level of carrier wave transmitted in 0s must be guaranteed, otherwise SCM label received will be severely distorted.

The last requirement directly compromises quality and the Q-factor of host signal. Minimum extinction ratio specified for SDH equipment [4] is 8.2 dB or 10.0 dB, and 9.0 dB for 1 Gbit/s gigabit Ethernet [35] in order to maximize receiver performance. Experiments with high frequency SCM-DPSK labels [19] involved reduction of host extinction ratio to as low as 3 dB, causing severe power penalties. Such arrangements do not, however, directly violate

10 Gbit/s gigabit Ethernet standard [36], specifying minimum extinction ratios of 3.0 dB or 3.5 dB only to allow use of low cost lasers and modulators.

4.1.3.1. Dispersion fading

Transmission of high frequency pilot tone or subcarrier-modulated data stream by means of amplitude (intensity) modulation is unfortunately subject to severe impairments caused by fiber dispersion. Chromatic dispersion (CD) produces a phase shift between two sidebands, increasing in proportion to CD coefficient and fiber length:

$$\Delta\phi = 4\pi LD\lambda_C^2 f_L^2 / c, \quad (4)$$

where: $\Delta\phi$ —phase shift [rad]; λ_C —host carrier wavelength [nm]; f_L —label frequency [GHz]; L —fiber length [km]; D —fiber chromatic dispersion coefficient [ps/nm·km]; LD —link chromatic dispersion [ps/nm]; c —speed of light [approx. $2.99792 \cdot 10^8$ m/s].

As the sidebands are of equal amplitude, when their relative phase shift reaches 180 degrees ($\Delta\phi = \pi$), respective photocurrents generated in non-coherent, wideband photo detector cancel each other and the label is lost. This border condition is defined by equation [31]:

$$2LD\lambda_C^2 f_L^2 = c. \quad (5)$$

Corresponding length of fiber link is:

$$L_{LOSS} = c / 2D\lambda_C^2 f_L^2. \quad (6)$$

A 3 dB ($1/\sqrt{2}$) reduction of receiver output voltage occurs at phase shift of 90° ($\pi/2$), which can be assumed as practical limit of label transmission. This happens at link length equal to:

$$L_{max} = c / 4D\lambda_C^2 f_L^2. \quad (7)$$

This phenomenon is known as “RF dispersion fading” and constitutes important performance limit in frequency-multiplexed (SCM) fiber transmission systems.

For the following, typical parameters of STM-16 channel in C-band system implemented with G.652 fiber: $\lambda_C = 1550$ nm, $D = 17$ ps/nm·km, $f_L = 3$ GHz, we get $L_{LOSS} = 1836$ km and $L_{max} = 918$ km. The latter value is lower than dispersion-limited length of 2.5 Gbit/s link on G.652 fiber, estimated at 1000 km. This is not surprising, because bandwidth of typical STM-16 receiver is only 1.8–2.0 GHz.

With proper choice of label frequencies and adequate power margin over host signal, say 5 dB, label and host are compatible in terms of CD and PMD tolerance. Label frequency significantly higher than host bandwidth is not feasible without additional dispersion compensation. As choice of label frequency depends on spectrum of particular host signal, network transparency is restricted or lost.

Use of amplitude- (AM) and phase-modulated (PM) labels is proposed for monitoring of dispersion in systems with

adaptive CD compensation [31, 32]. PM labels provide better accuracy in presence of PMD and fiber nonlinearity. Experiments with FSK, PSK and DPSK modulation of optical carrier reported better performance and overhead bit rates up to 2.5 Gbit/s [19]. This method requires single mode laser with good frequency stability, so is predominantly applicable to DWDM equipment for core networks.

4.1.4. Phase and frequency modulation of optical host carrier

Researchers participating in STOLAS project have proposed several methods for adding overhead of considerable capacity (155 Mbit/s) to 10 Gbit/s host, by differential phase shift keying (DPSK) [24] or frequency shift keying (FSK) of the optical carrier wave carrying the amplitude keyed (NRZ) scrambled STM-64 host. The expected penalty in case of DPSK label was an increase of host jitter due to interaction with fiber dispersion, limited to about 0.02 unit intervals (UI) at maximum allowable path dispersion of 1500 ps/nm. Laser used here must emit radiation with very narrow spectral width, well below 50% of label clock frequency. For label detection, a DPSK-ASK conversion is provided by Mach-Zehnder interferometer with fiber delay line placed in one arm.

Frequency shift keying modulation can be imposed by directly adding label pulses to laser bias current.

4.1.5. Insertion of label bits into fixed locations within frame of the host signal

This is a kind of time division multiplexing utilizing spare capacity in frame structure, where specific, easily recognizable bit patterns are formed. Repetitive patterns can create low-frequency component in signal spectrum, detectable by narrow-band receiver without decoding host signal or recognized by simple (but fast) logic circuits. For example, alternatively inserting a string of 0s in 4 frames and equally long string of 1s in the next 4 frames creates AM component at 1/8th of frame repetition frequency. The first case is an alternative implementation of pilot tone method (Section 4.1.1).

Bit pattern label is not truly orthogonal, as it requires host signal of specific frame structure. It also prevents use of spare bits for other purposes, like in-band FEC or user data channels. Host signals with little or no spare bits cannot support this technique.

Bit insertion labels have unique advantages:

- can transit through properly configured O/E/O repeaters, transponders and other active devices;
- do not degrade receiver sensitivity;
- can be read very quickly;
- are generated by standard digital circuits handling host signal;

- can be accessed by multiplexers, routers or transmission analyzers with upgraded software.

Fast readout makes bit pattern labels attractive for routing purposes in networks carrying one type of traffic from diverse sources. Problems include:

- difficulty with adding a label to signal in transit without using costly O/E/O conversion;
- limited choice of label frequencies, usually tied to frame repetition frequency of host signal;
- possible interference to optical amplifiers with closed-loop gain control.

4.1.5.1. Bit pattern labeling of SDH streams

ITU-T Recommendation G.707 [2] reserves up to 30 bytes within STM-1 frame for various uses, so labeling does not violate existing standards. Frame repetition frequency is 8 kHz, so available pilot tone frequencies are 4 kHz (8 kHz/2), 2.6667 kHz (8 kHz/3), etc. STM-1 frame consists of 2430 bytes and has average mark ratio of 50%. Setting content of N bytes in alternate frames to 0s and 1s causes frame-to-frame relative power variation of:

$$N/(2430/2) = 8.23 \cdot 10^{-4}N \text{ or } 0.0823\% \text{ per byte.} \quad (8)$$

Filtering the envelope to pass pilot tone only results in modulation index m of approx. 0.05% per byte. Utilization of 4 bytes gives modulation index $m = 0.2\%$; reserving more bytes is not realistic due to multiple demands for this limited resource. This value shall be adequate for reliable detection of static pilot tone, and give at least 20 dB of dynamic range for amplitude measurements with typical filter bandwidth of 20 Hz or less.

Time multiplexing does not remove labels, but modulation index is reduced in proportion to bit rate. Therefore, an STM-1 stream labeled with pilot tone generated by 4 bytes and subsequently multiplexed to STM-64 level will have to be identified with $m = (0.2/64)\% = 0.0031\%$ only. Setting all 64 label patterns identical restores original m value, but individual tributaries are no longer traceable.

As 28 out of 30 reserved bytes within STM-1 frame are subject to scrambling, the label pattern must be pre-coded to result in desired sequence after scrambling.

Overhead capacity can be increased dramatically by taking away a part of payload capacity to create a strong, easy to read label, e.g., replacing one or more of STM-1 tributaries with streams of alternating fixed bit sequences, to create a modulated subcarrier. Modulation scheme must minimize components below ≈ 100 kHz, to avoid interference to EDFA controllers and inter-modulation between channels.

Such approach results in impressive performance [34], but is incompatible with existing standards and involves considerable loss of transmission capacity. Marking of SDH streams in transit is not possible.

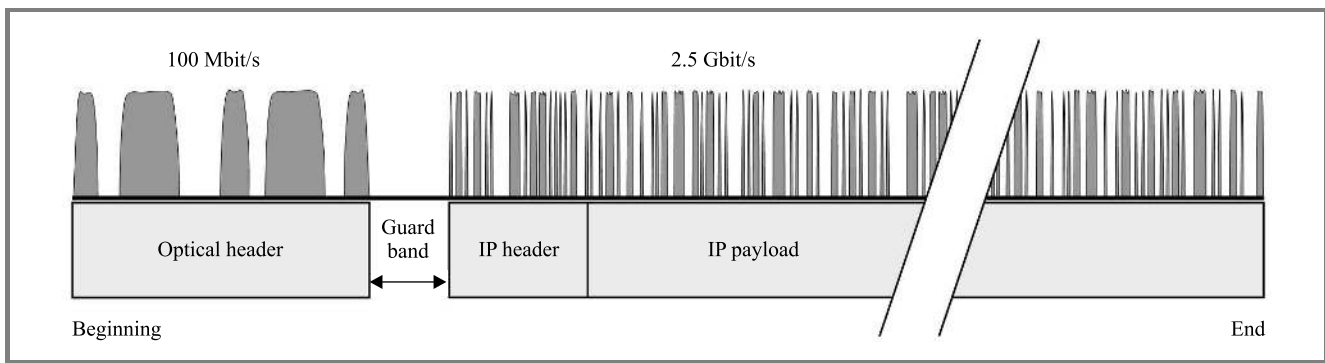

Fig. 12. Structure of optical packet.

4.2. Labeling in optical packet networks

Due to nature of packet networks, where individual packets are handled by several nodes in random order and generally do not form a continuous bit stream while in transit, there is a strong demand for “label swapping”—removal of existing label (or part of it) and replacing it with new one generated locally. Packet can undergo such operation in several nodes. Equivalent operations are routinely performed by electronic packet switching equipment in use today.

In optical packet networks, a label is added to every single data packet. Labels must be read fast, in order to effect packet routing without delay. There is no optical equivalent of random access memory (RAM) used for buffering data in electronic switches, except for fixed length, costly and bulky fiber delay lines. Readout time specified is measured as fraction of packet length. For example, allowing 20% of duration of 1024-byte, 10 Gbit/s packet gives 164 ns for label detection. Packets have standardized bit rate and structure, so label orthogonality is not essential.

Label handling devices are expected to be part of complex core routers and switches, so their cost and complexity are of lesser importance, but reliability requirements are high. The field is open for advanced components, initially manufactured in limited quantities.

4.2.1. Header (bit sequence) labeling of optical packets

This scheme is equivalent to solution used in electronic networks: the main (payload) part of packet is preceded by a header carrying routing and identification data (Fig. 12), whose contents is accessible to switching nodes, test equipment, etc.

The drive to transmit data optically at highest rates possible (40 Gbit/s and beyond) has resulted in “electronic bottleneck”: existing digital circuits cannot directly handle them, or are prohibitively expensive and power consuming. Those are exactly the reasons for introduction of optical switching.

To allow readout of label (header) by inexpensive electronic receivers, label bit rate is often lower than payload rate, e.g., 100 Mbit/s versus 2.5 Gbit/s or 40 Gbit/s, as shown in Fig. 12. The payload itself comprises its own header, utilized by lower network layers. To allow for timing errors

and enable proper receiver synchronization, both parts are separated by a guard band. This is unlike electronic systems where both rates are identical.

This header-payload split has a far-reaching consequence: one can envision a network, where payloads are of different bit rates, formats and lengths, but headers are all standardized and the optical core is “transparent” and upgradeable.

Lower bit rate means proportionally decreases receiver noise and input power required, so tapping a small portion of signal passing given node, e.g., 10% provides enough input power for header detection. “Slow” header is substantially more resistant to dispersion than payload, and pulse quality requirements (extinction ratio, rise/fall time, chirp, etc.) can be relaxed, with margin for degradation and added noise resulting from label swapping process. Dispersion management becomes more flexible, as “slow” headers are readable at any location along optical path, without accurate dispersion compensation required for payload.

4.2.1.1. Label swapping

Old header can be removed using gated semiconductor optical amplifier, as this device is compact, fast and potentially inexpensive. New label is added using DFB laser transmitter and optical coupler. A simple arrangement of optical header processor is shown (Fig. 13); several other variants are known from literature [10, 24, 37]. All active components are suitable for integration as single monolithic or hybrid IC. More complex processors [37] containing additional Mach-Zehnder interferometers, tunable laser and SOA are able to perform flexible wavelength conversion as well.

Implementation of scheme shown in Fig. 13 raises several design issues:

- label receiver must work with bursty signals, quickly synchronizing after idle period of random duration;
- total delay of lower and upper signal paths (including processing time) must be equal;
- levels and wavelengths of new label and payload must be precisely matched.

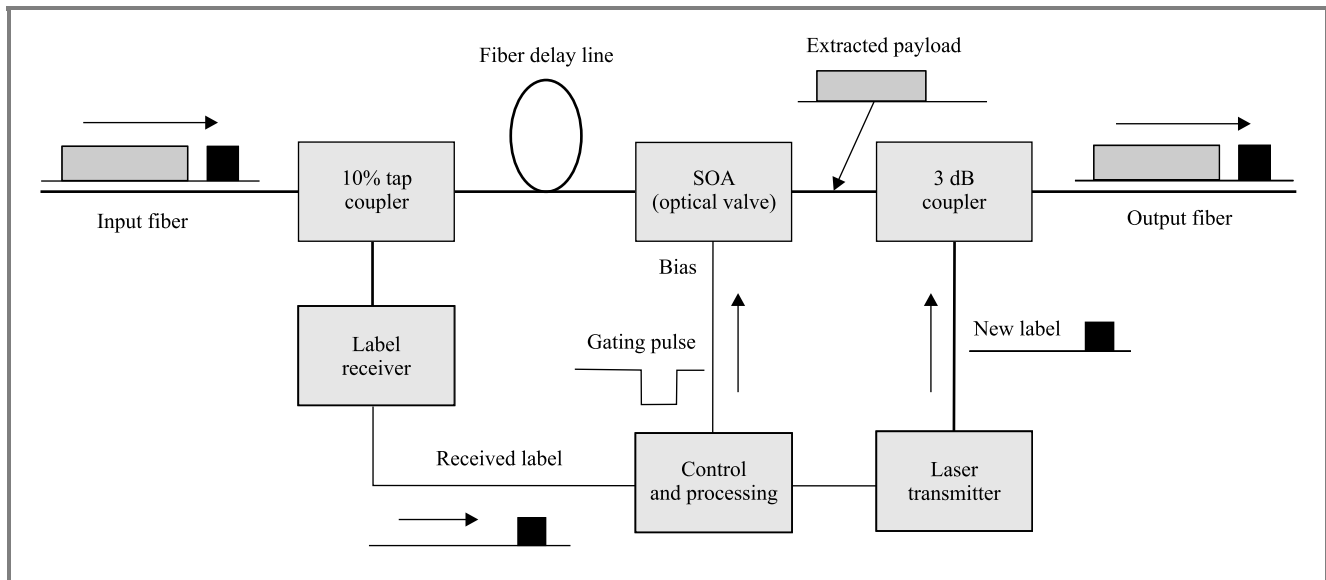

Fig. 13. Simple header processor for optical packet network.

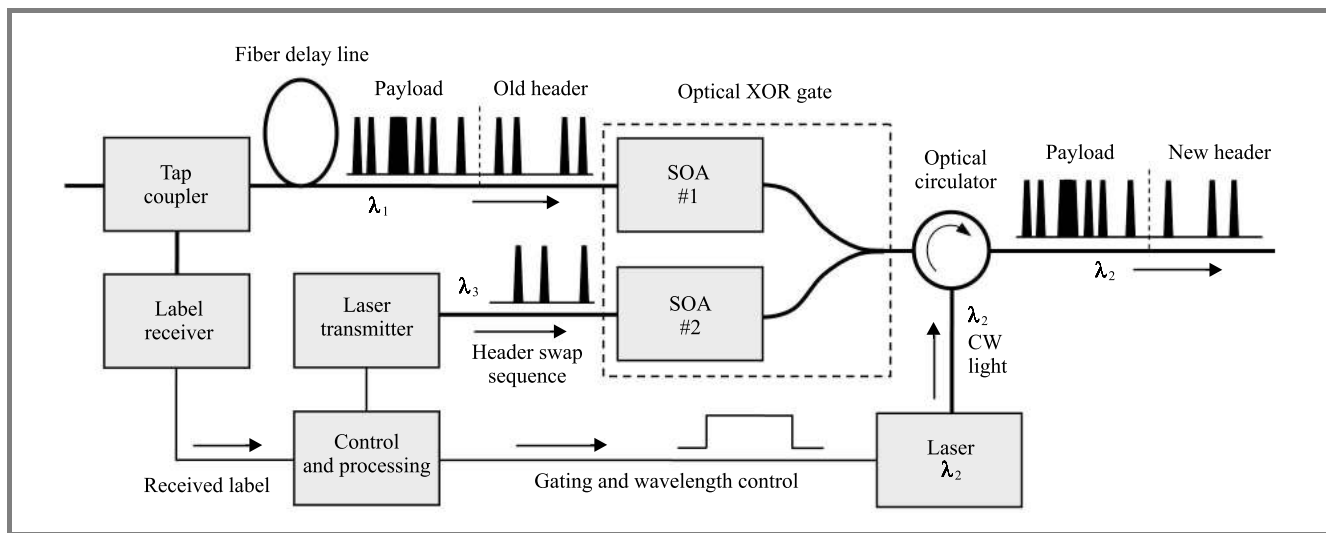

Fig. 14. Header processor with wavelength conversion.

Without wavelength match, transmission over longer distances results in relative shifting of label and payload due to fiber chromatic dispersion. More complex label processing schemes include transfer of both label and payload to new wavelength, using interferometric wavelength converter, also known as optical XOR gate (Fig. 14). Such a device has already been made as single monolithic circuit.

Tests with 10 Gbit/s packets and headers, both of them RZ-coded, converted from 1538 nm to 1543 nm revealed satisfactory performance: 0.4 dB power penalty due to wavelength conversion and 13 dB extinction ratio of the output signal [19].

4.2.2. WDM labeling of optical packets

The header can be sent on wavelength(s) separate from the payload. This technique has advantages:

- routing decisions can be generated by optical correlation of pulses, resulting in **purely optical** switching technology;
- reliable separation of label and payload, which can overlap in time; there are no limits to header size;
- use of techniques and components already developed for WDM networks.

Unfortunately, it is wasteful in DWDM networks, as header occupies at least one more wavelength. DWDM lasers and multiplexers are expensive, although adoption of CWDM technology will reduce costs. There are numerous research papers on this subject, most of them from Japan [23, 25, 26].

The primary reason for researching this complicated technology is its potential for purely optical and extremely fast core switches, with no electronics handling packet control

functions. In several experiments, a set of wavelengths served as “signaling channel”, with routing data encoded as combinations of present and absent pulses. Complete header is then read using optical correlators based on set of fiber or waveguide delay lines and couplers.

Very fast routing in core network (between limited number of nodes) is accomplished by use of lookup tables, containing predefined new headers and sets of switching and wavelength conversion instructions. A purely optical technology to implement this function is not yet available.

4.2.3. SCM labeling of optical packets

High frequency SCM labeling is often proposed for optical packet networks. Carrier frequencies are usually higher than clock rate of payload bit stream (≥ 3 GHz) and efficient transmission of label often requires restricted extinction ratio of the host signal. The most common method of label carrier modulation is DPSK.

Label bit rates are in order of 100 Mbit/s and higher, therefore even a short packet carries adequate amount of overhead. For example, a 155 Mbit/s label imposed on 256-byte long 2.5 Gbit/s packet consists of 16 bytes, although considerable part of it must be sacrificed to allow for burst synchronization of receiver at the beginning of packet.

The method is robust, effective and can be implemented with existing components. Semiconductor amplifiers may perform amplitude modulation in transit nodes, working in non-saturated regime, with label signal added to bias current. Amplitude-modulated label may be erased by the same SOA working in saturated regime. Unfortunately, dispersion fading problems discussed in Section 4.1.3.1 may constitute a serious limit on transmission distance or fiber type used and impose more strict dispersion compensation requirements.

5. Conclusions

There are several options for labeling and attaching extra information to signals transmitted in transparent optical networks. Few technologies developed for this purpose have found other applications, like monitoring of path dispersion and detecting network intrusions.

Unfortunately, international standards have not emerged despite extensive, but extremely divergent research activity. Interest in building high performance all-optical core networks is currently missing due to worldwide downturn in telecom sector, so most optical labeling technologies have to wait for future applications.

Exceptions include use of simple pilot tones and subcarrier modulation techniques in transoceanic systems and for protection of high security networks. Both applications are distanced from mainstream activities of most networks operators in Central Europe.

References

- [1] “Interfaces for the optical transport network (OTN)”, ITU-T Rec. G.709/Y.1331 (12-2003).
- [2] “Network node interface for the synchronous digital hierarchy (SDH)”, ITU-T Rec. G.707/Y.1322 (12-2003).
- [3] “Optical interfaces for multichannel systems with optical amplifiers”, ITU-T Rec. G.692 (06-2002).
- [4] “Optical interfaces for equipments and systems relating to the synchronous digital hierarchy”, ITU-T Rec. G.957 (12-2003).
- [5] H. C. Ji, K. J. Park, J. K. Kim, and Y. C. Chung, “Optical path and crosstalk monitoring technique using pilot tones in all-optical WDM transport network”, in *Proc. SPIE, APOC 2001*, Beijing, China, 2001, vol. 4584.
- [6] K. U. Chu, C. H. Lee, and S. Y. Shin, “Optical path monitoring based on the identification of optical cross-connect input ports”, in *Opt. Fib. Commun. Conf. OFC’99*, San Diego, USA, 1999, Paper FJ5.
- [7] H. C. Ji, K. J. Park, J. K. Kim, S. K. Shin, M. J. Jang, and Y. C. Chung, “Demonstration of optical path monitoring technique using dual pilot tones in all-optical WDM transport network”, in *OptoElectron. Commun. Conf. OECC*, Chiba, Japan, 2000 (published in *Tech. Dig.*, 2000, Ser. 5).
- [8] K. J. Park, S. K. Shin, and Y. C. Chung, “A simple monitoring technique for WDM networks”, in *Conf. OFC’99*, San Diego, USA, 1999, Paper FJ3.
- [9] H. S. Chung, S. K. Shin, H. G. Woo, and Y. C. Chung, “Effects of stimulated Raman scattering on pilot-tone based WDM supervisory technique”, in *Conf. OFC’2000*, Baltimore, USA, 2000, Paper WK7-1.
- [10] Y. G. Wen, Y. Zhang, and L. K. Chen, “On architecture and limitation of optical multiprotocol label switching (MPLS) networks using optical-orthogonal-code (OOC)/wavelength label”, *Opt. Fib. Technol.*, vol. 8, no. 1, pp. 43–70, 2002.
- [11] R. Gaudino and D. J. Blumenthal, “WDM channel equalization based on subcarrier signal monitoring”, in *Conf. OFC’98*, San Jose, USA, 1998, Paper WJ6.
- [12] E. Kong, F. Tong, K. P. Ho, L. K. Chen, and C. K. Chan, “An optical path supervisory scheme for optical cross-connects using pilot tones”, in *CLEO Pacific Rim 1999*, Seoul, Korea, 1999, Paper FT4.
- [13] M. Murakami, T. Imai, and M. Aoyama, “A remote supervisory system based on subcarrier overmodulation for submarine optical amplifier systems”, *J. Lightw. Technol.*, vol. 14, no. 5, pp. 671–677, 1996.
- [14] N. Suzuki, K. Shimizu, T. Kogure, J. Nakagawa, and K. Motoshima, “Optical fiber amplifiers employing novel high-speed AGC and tone-signal ALC functions for WDM transmission systems”, in *Conf. ECOC 2000*, Munich, Germany, 2000, vol. 2, p. 179.
- [15] Y. Hamazumi and M. Koga, “Transmission capacity of optical path overhead transfer scheme using pilot tone for optical path network”, *J. Lightw. Technol.*, vol. 15, no. 12, pp. 2197–2205, 1997.
- [16] Y. Sun, A. A. M. Saleh, J. L. Zyskind, D. L. Wilson, A. K. Srivastava, and J. W. Sulhoff, “Time dependent perturbation theory and tones in cascaded erbium-doped fiber amplifier systems”, *J. Lightw. Technol.*, vol. 15, no. 7, pp. 1083–1087, 1997.
- [17] Y. C. Chung, “Wavelength control and monitoring in WDM networks”, in *All Opt. Netw. ComForum IEC*, Orlando, USA, 1999.
- [18] M. C. R. Medeiros, I. Darwazeh, L. Moura, A. L. Barradas, A. Teixeira, P. André, M. Lima, and J. da Rocha, “Dynamically allocated wavelength WDM network demonstrator”, in *Proc. ConfTele 2001*, Figueira da Foz, Portugal, 2001, pp. 169–173.
- [19] N. Chi, B. Carlsson, Z. Jianfeng, P. Holm-Nielsen, Ch. Peucheret, and P. Jeppesen, “Transmission properties for two-level optically labeled signals with amplitude-shift keying and differential phase-shift keying orthogonal modulation in IP-over-WDM networks”, *J. Opt. Netw.*, vol. 2, no. 2, pp. 46–54, 2003.
- [20] T. Koonen, S. Sulur, I. T. Monroy, J. Jennen, and H. de Waardt, “Optical labeling of packets in IP-over-WDM networks”, in *Proc. URSI Gen. Assem. 2002*, Maastricht, The Netherlands, 2002, Oral Paper no. 1526.

- [21] S. Sulur, T. Koonen, I. T. Monroy, H. de Waardt, and J. Jennen, "IP over DWDM networks supported by GMPLS-based LOBS deploying combined modulation format", in *Opticomm 2001*, Denver, USA, 2001.
- [22] T. Koonen, G. Morthier, J. Jennen, H. de Waardt, and P. Demeester, "Optical packet routing in IP-over-WDM networks deploying two-level optical labeling", in *Eur. Conf. Opt. Commun. ECOC-2001*, Amsterdam, The Netherlands, 2001, Paper ThL.2.1.
- [23] H. Harai and N. Wada, "Photonic packet forwarding in a multi-wavelength label switching node", in *IEEE ICC Works. Next Gen. Switch./Rout.: Opt. Role*, Helsinki, Finland, 2001.
- [24] T. Fjelde, "Novel scheme for efficient label-swapping using simple XOR gate", in *Conf. ECOC-2000*, Munich, Germany, 2000, Paper 10.4.2.
- [25] J. McGeehan, M. C. Hauer, A. B. Sahin, and A. E. Willner, "Reconfigurable multi-wavelength optical correlator for header-based switching and routing", in *Conf. OFC'2002*, Anaheim, USA, 2002, Paper WM4.
- [26] A. Okada, "All-optical packet routing in AWG-based wavelength routing network using out-of-band optical label", in *Conf. OFC'2002*, Anaheim, USA, 2002, Paper WG1.
- [27] V. J. Hernandez, Z. Pan, J. Cao, V. K. Tsui, Y. Bansai, S. K. H. Fong, Y. Zhang, M. Y. Jeon, and S. J. B. Yoo, "First field trial of optical label-based switching and packet drop on a 477 km NTON/sprint link", in *Conf. OFC'2002*, Anaheim, USA, 2002, Paper TuY4.
- [28] H. J. Lee, S. J. B. Yoo, V. Tsui, and S. K. H. Fong, "A simple all-optical label detection and swapping technique incorporating a fiber Bragg grating filter", *IEEE Photon. Technol. Lett.*, vol. 13, no. 6, pp. 635–637, 2001.
- [29] G. Bendelli, C. Cavazzoni, R. Girardi, and R. Lano, "Optical performance monitoring techniques", in *Conf. ECOC-2000*, Munich, Germany, 2000, vol. 4, p. 113.
- [30] K. Kitayama, N. Wada, and H. Sotobayashi, "Architectural considerations for photonic IP router based upon optical code correlation", *J. Lightw. Technol.*, vol. 18, no. 12, pp. 1834–1844, 2000.
- [31] G. Rossi, T. E. Dimmick, and D. J. Blumenthal, "Optical performance monitoring in reconfigurable WDM optical networks using subcarrier multiplexing", *IEEE J. Lightw. Technol.*, vol. 18, no. 12, pp. 1639–1648, 2000.
- [32] K. J. Park, C. J. Youn, J. H. Lee, and Y. C. Chung, "Performance comparisons of chromatic dispersion-monitoring techniques using pilot tones", *IEEE Photon. Technol. Lett.*, vol. 15, no. 6, pp. 873–875, 2003.
- [33] "National Communications System—Technical Information Bulletin 00-7: All-Optical Networks (AON)", Office of the Manager, National Communications System, Arlington, USA, 2000.
- [34] Y. Horiuchi and M. Suzuki, "Ultra-robust optical routing by digitally encoded SCM label", in *Conf. OFC'2002*, Anaheim, USA, 2002, Paper TuV3.
- [35] "IEEE Standard for Information Technology—Telecommunications and Information Exchange Between Systems—Local and Metropolitan Area Networks—Specific Requirements". Part 3: "Carrier Sense Multiple Access with Collision Detection (CSMA/CD) Access Method and Physical Layer Specifications", IEEE Std 802.3-2002.
- [36] "IEEE Standard for Information Technology—Telecommunications and Information Exchange Between Systems—Local and Metropolitan Area Networks—Specific Requirements". Part 3: "Carrier Sense Multiple Access with Collision Detection (CSMA/CD) Access Method and Physical Layer Specifications". Amendment: "Media Access Control (MAC) Parameters, Physical Layers, and Management Parameters for 10 Gb/s Operation", IEEE Std 802.3ae-2002.
- [37] D. Blumenthal, J. Bowers, and L. Coldren, "Integrated photonic modules for all-optical label swapping in WDM/TDM networks", in *DARPA NGI PI Rev.*, Santa Barbara: University of California, 2000.



Krzysztof Borzycki was born in Warsaw, Poland, in 1959. He received the M.Sc. degree in electrical engineering from Warsaw University of Technology in 1982. He has been with National Institute of Telecommunications (NIT) since 1982, working on optical fiber fusion splicing, design of optical fiber transmission systems, measurement

methods and test equipment for optical networks, as well as standardization and conformance testing of optical fiber cables, SDH equipment and DWDM systems. Other activities included being a lecturer and instructor in fiber optics and technical advisor to Polish fiber cable industry. He has also been with Ericsson AB research laboratories in Stockholm, Sweden, working on development and testing of DWDM systems for long-distance and metropolitan networks between 2001 and 2002 while on leave from NIT. He is currently working toward Ph.D. degree, focusing on adding overhead information to optical signals for network management and switching purposes. Other important research activity is investigation of aging and temperature effects on polarization mode dispersion (PMD) in optical fibers and cables. He is an author or co-author of 1 book, 2 Polish patents and more than 30 scientific papers in the field of optical fiber communications, optical fibers and measurements in optical networks, as well as one of *Journal of Telecommunications and Information Technology* editors.

e-mail: k.borzycki@itl.waw.pl

National Institute of Telecommunications

Szachowa st 1

04-894 Warsaw, Poland