

Laboratory automatic measuring system for gamma specimens

Adrian Jakowiuk,
Paweł Filipiak,
Jakub Bartak,
Paweł Pieńkos,
Ewa Kowalska

Abstract. LG Gamma Counter is designed for low activity measurement of the radioactive isotope iodine ^{125}I in liquid or solid samples during radioimmunoassay (RIA) and immunoradiometric assay (IRMA) in small or medium size clinic laboratories. Apart from RIA and IRMA programmed procedures, a measurement of small activity gamma samples is possible. The well scintillator NaI(Tl) is used as radiation detector for the isotope ^{125}I in the measuring channel, the well dimensions Φ being 17×38 mm. Gamma Counter was adapted for measuring radioactivity of single samples. The counter is equipped with an automatic system allowing transportation of examined samples to a scintillator well. The gauge is based on an integrated computer which is working under the control of Windows CE and is equipped with special software allowing for setting measurement parameters and communication with an external computer. The measured sample is placed inside the scintillator well either by an automatic sample feeder or manually. The pulses from a photomultiplier tube after amplification and shaping in pulse amplifiers are counted in the window of a single channel analyser by a programmable pulse counter under the control of microprocessor system. The measured count rate is the measure of activity of the assayed sample. Expected count rate error due to unstable operation of amplification is lower than 1%.

Key words: gamma counter • radioimmunoassay (RIA) • immunoradiometric assay (IRMA)

Introduction

Radioimmunoassay (RIA) and immunoradiometric assay (IRMA) are widely used in clinic laboratories permitting the determination of hormone concentrations and other substances in body fluids [1]. The physician is able to confirm or to exclude a disease, to determine disease severity, to trace the health status of a patient after a medical treatment or to plan further treatments.

An important role in radioimmunoassay play measurements of samples containing radioactive isotope (most frequently iodine ^{125}I) and then, computation of concentration of the determined substance in investigated sample. Large size laboratories employ for this purpose multi-well gamma counters or gamma counters with automatic sample changing [2]. On the other hand, for medium and small size laboratories a single-well gamma counter seems sufficient. To satisfy the demand for RIA and IRMA measurements in small and medium size clinic laboratories a single channel LG Gamma Counter (Fig. 1), designed for low activity measurements of radioactive isotope iodine ^{125}I in liquid samples, was developed.

Apart from RIA and IRMA programmed procedures, a measurement of small activity gamma samples is possible. The counter can be optionally equipped with an automatic system allowing transportation of the examined samples into the scintillator well.

A. Jakowiuk✉, P. Filipiak, J. Bartak, P. Pieńkos,
E. Kowalska
Institute of Nuclear Chemistry and Technology,
16 Dorodna Str., 03-195 Warsaw, Poland,
Tel.: +48 22 504 1218, Fax: +48 22 811 1532,
E-mail: a.jakowiuk@ichtj.waw.pl

Received: 27 October 2011
Accepted: 31 January 2012

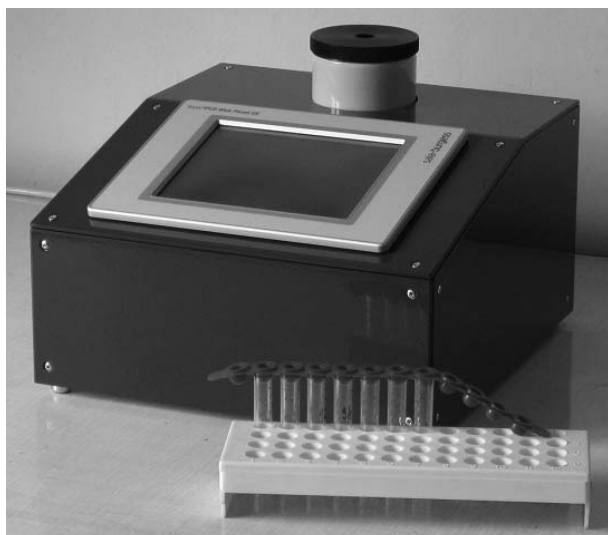

Fig. 1. LG Gamma Counter.

Principle of operation

Block diagram illustrating the principle of operation of Gamma Counter is shown in Fig. 2. The measured sample is placed inside the well of well scintillator SC, type NaI(Tl). Pulses from the photomultiplier tube output after amplification and shaping in pulse amplifiers A1 and A2 are counted in the window (W1) of a single channel analyser by a programmable pulse counter under the control of microprocessor system. The obtained count rate indicates (after multiplication by respective coefficient) the activity of the measured sample.

The light emitting diode LED placed in the optical fiber SW and a pulse generator GI are used to produce reference light pulse needed for automatic gain control of measuring channel. During the gain control process, the generator GI is activated. The pulses from the pulse generator supply the light emitting diode and the pulses are generated. Just after the gauge is switched on, the microprocessor system starts to increase high voltage of the photomultiplier's tube FP using the digit-to-analog converter (DAC). It controls simultaneously through the analog-to-digit converter (ADC) whether the amplitude of reference pulse exceeds reference

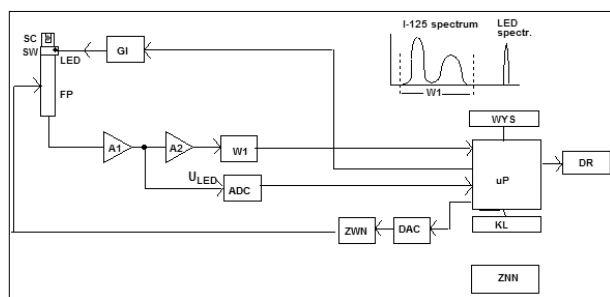

Fig. 2. Gamma Counter block diagram. SC – well scintillator NaI(Tl), well dimensions $\Phi 17 \times 38$ mm; SW – optical fiber; LED – light emitting diode; FP – photomultiplier; GI – pulse generator, approx. 1000 cps; A1 – pulse amplifier; A2 – pulse amplifier; W1 – single channel analyser; ADC – analog-to-digit converter; ZNN – low voltage power supply; ZWN – high voltage power supply; DAC – digit-to-analog converter; μ P – microprocessor's block; WYS – LCD display; KL – keyboard; DR – external printer.

voltage or not. When the nominal value U_{LED} is reached, increasing of the photomultiplier's voltage is stopped and the gain control process is finished. Automatic gain control is carried out as the first activity after the gauge is switched on. Additionally, the gain of measuring channel is checked whenever new measurements are carried out and correction is done when needed.

The block of microprocessor

The block of microprocessor consists of two parts:

- System of microprocessor is responsible for the control and proper work of internal circuits, it communicates through a special communication protocol with the integrated computer.
- Integrated computer is equipped with a special software, allowing setting the measurement parameters and communication with an external computer.

The block of microprocessor is equipped with a wireless data transmission (Bluetooth communication protocol) to the external computer.

Mechanical construction

Figure 3 shows the scintillation detector cover protecting from the gamma radiation background.

The scintillator gauge cover made of lead is an important construction element. It protects the scintillator well from the effect of the background of cosmic radiation and the radioactive elements found in the Earth's crust. Scintillation probe diameter equals 50 mm (photomultiplier diameter equals 38 mm). Dimensions of SDN.64 scintillator equal $\Phi 37 \times 48$ mm, well dimensions – $\Phi 17 \times 38$ mm. The measured samples can be placed inside the scintillator well either by an automatic sample feeder or manually.

Processing of measured signal

Taking into consideration dead time of the measuring channel, the real pulse count rate is given by the relation:

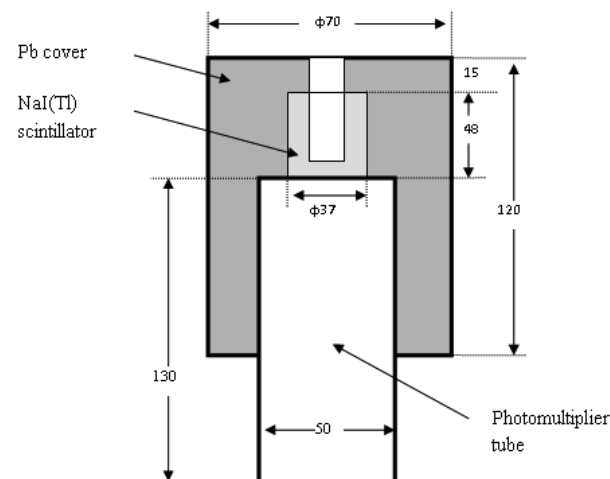

Fig. 3. NaI(Tl) scintillator cover made of lead.

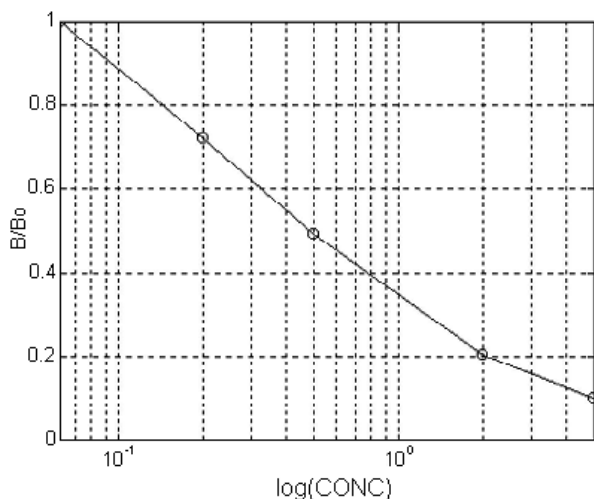

Fig. 4. Calibration curve for RIA assay.

$$(1) \quad r_r = \frac{r_m}{1 - r_m \tau} \text{ (cpm)}$$

where: r_r – real pulse count rate (cpm); r_m – measured pulse count rate (cpm); τ – dead time of measuring channel (min).

For dead time of the measuring channel, approx. 1 μ s, the real and the measured pulse count rate differ from each other not more than 0.4%. Such a difference, comparing to other measurement errors, can be neglected. Pulse count rate takes into account the background radiation and is computed from the relation:

$$(2) \quad r = r_r - r_b$$

where: r – pulse count rate from the measured sample (cpm); r_b – background count rate (cpm).

Digital signal processing of measured signal allows to determine concentration from the calibration curves of two types:

- RIA – decreasing pulse count rate as a function of increasing substance concentration – according to the equation: $\ln(B/B_0)$ vs. $\log(\text{CONC})$ (Fig. 4).
- IRMA – increasing pulse count rate in a function of increasing substance concentration – according to the equation: $\log(B/T)$ vs. $\log(\text{CONC})$ (Fig. 5) where: CONC – substance concentration of the measured sample, B_0 – pulse count rate for $\text{CONC} = 0$, B – pulse count rate for $\text{CONC} \neq 0$, T – pulse count rate for the sample with maximum activity.

Calibration curve B/B_0 vs. concentration can be prepared in the two ways:

- by combining data points with straight line segments;
- by determining regression curve using a spline interpolation method.

The concentration of unknown samples is determined from a calibration curve.

Pulse count rate error or concentration error from the repeated measurements can be computed from the relation:

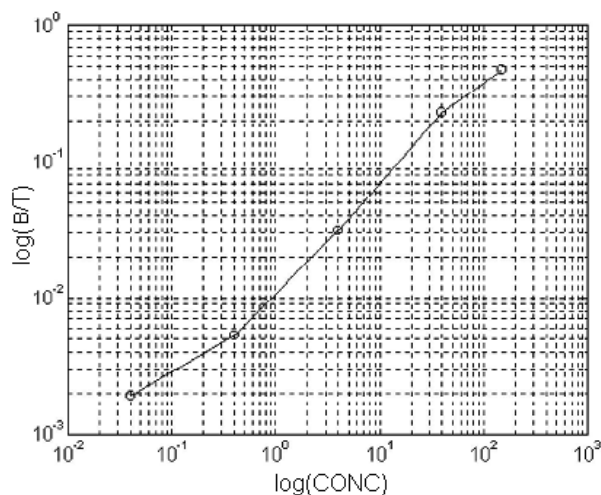

Fig. 5. Calibration curve for IRMA assay.

$$(3) \quad CV = \sqrt{\frac{\sum_i (x_i - \bar{x})^2}{n - 1}} / \bar{x}$$

where: CV – relative standard deviation; x_i – successive measurement; \bar{x} – mean value; n – number of measurements.

Conclusion

This low price and single channel gamma counter equipped with an integrated computer can fully satisfy the demand of small and medium size laboratories. Available functions (menu), displayed on the counter display and the functions make the operation of Gamma Counter friendly and easy for the user. By increasing the computing power, the gauge can use more complex calculation methods, like a spline interpolation method, so that the digital processing of measurement results ensures a high accuracy of the analysis. Simplicity of operation makes the Gamma Counter a very convenient instrument for measurements in medical laboratories.

Acknowledgment. This project is co-financed by the European Union from the European Regional Development Fund, ‘New generation of intelligent radiometric tools with wireless data transmission’ (UDA-POIG.01.03.01-14-065/08 from 20-02-2009).

References

1. Chard T (1995) An introduction to radioimmunoassay and related techniques, 5th ed. Elsevier, Amsterdam, New York
2. Packard cobra gamma counters. <http://www.gmi-inc.com/Packard-Cobra-Gamma-Counter.html>