

AD-A125 784

LAMINATE ANALYSES MICROMECHANICAL CREEP RESPONSE AND
FATIGUE BEHAVIOR OF. (U) WYOMING UNIV LARAMIE DEPT OF
MECHANICAL ENGINEERING D F ADAMS DEC 82

1/1

UNCLASSIFIED

UMME-DR-201-108-1 ARO-16370. 10-MS

F/G 11/4

NL

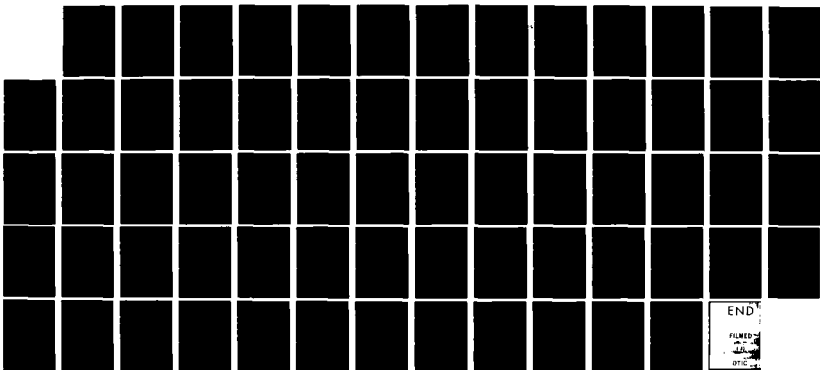

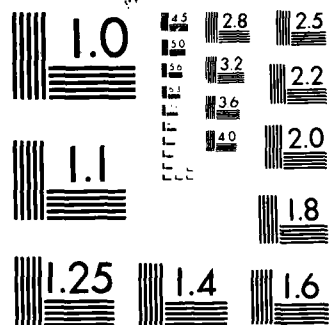

MICROCOPY RESOLUTION TEST CHART
NATIONAL BUREAU OF STANDARDS 1963-A

DEPARTMENT REPORT UWME-DR-201-108-1
ARO 16370.10-MS

**LAMINATE ANALYSES,
MICROMECHANICAL CREEP RESPONSE,
AND FATIGUE BEHAVIOR
of POLYMER MATRIX
COMPOSITE MATERIALS**

(12)

Donald F. Adams

December 1982

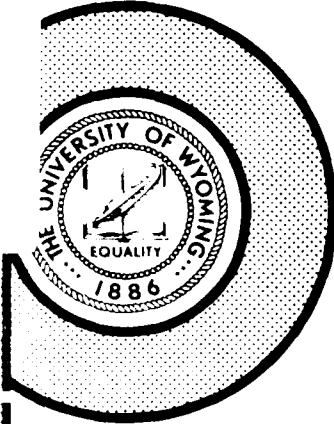

FINAL REPORT
U.S. Army Research Office
Grant No. DAAG 29-79-C-0189

DTIC FILE COPY

Approved for Public Release; Distribution Unlimited

03 17 004

COMPOSITE MATERIALS RESEARCH GROUP
DEPARTMENT of MECHANICAL ENGINEERING
University of Wyoming Laramie, Wyoming 82071

THE VIEWS, OPINIONS, AND/OR FINDINGS CONTAINED IN THIS REPORT ARE THOSE OF THE AUTHORS AND SHOULD NOT BE CONSTRUED AS AN OFFICIAL DEPARTMENT OF THE ARMY POSITION, POLICY, OR DECISION, UNLESS SO DESIGNATED BY OTHER DOCUMENTATION.

DEPARTMENT REPORT
UWME-DR-201-108-1

LAMINATE ANALYSES, MICROMECHANICAL CREEP RESPONSE,
AND FATIGUE BEHAVIOR OF POLYMER MATRIX COMPOSITE MATERIALS

DONALD F. ADAMS

DECEMBER 1982

FINAL REPORT

U.S. ARMY RESEARCH OFFICE
GRANT NO. DAAG 29-79-C-0189

COMPOSITE MATERIALS RESEARCH GROUP
MECHANICAL ENGINEERING DEPARTMENT
UNIVERSITY OF WYOMING
LARAMIE, WYOMING 82071

APPROVED FOR PUBLIC RELEASE; DISTRIBUTION UNLIMITED

Unclassified

SECURITY CLASSIFICATION OF THIS PAGE (When Data Entered)

REPORT DOCUMENTATION PAGE		READ INSTRUCTIONS BEFORE COMPLETING FORM
1. REPORT NUMBER	2. GOVT ACCESSION NO. AD-A12-5784	3. RECIPIENT'S CATALOG NUMBER
4. TITLE (and Subtitle) Laminate Analyses, Micromechanical Creep Response, and Fatigue Behavior of Polymer Matrix Composite Materials		5. TYPE OF REPORT & PERIOD COVERED Final Report 16 Sept. 1979 - 30 Nov. 1982
		6. PERFORMING ORG. REPORT NUMBER UWME-DR-201-108-1
7. AUTHOR(s) Donald F. Adams		8. CONTRACT OR GRANT NUMBER(s) DAAG 29-79-C-0189
9. PERFORMING ORGANIZATION NAME AND ADDRESS Composite Materials Research Group University of Wyoming Laramie, Wyoming 82071		10. PROGRAM ELEMENT, PROJECT, TASK AREA & WORK UNIT NUMBERS
11. CONTROLLING OFFICE NAME AND ADDRESS U. S. Army Research Office Post Office Box 12211 Research Triangle Park, NC 27709		12. REPORT DATE December 1982
		13. NUMBER OF PAGES 59
14. MONITORING AGENCY NAME & ADDRESS (if different from Controlling Office)		15. SECURITY CLASS. (of this report) Unclassified
		15a. DECLASSIFICATION/DOWNGRADING SCHEDULE N/A
16. DISTRIBUTION STATEMENT (of this Report) Approved for public release; distribution unlimited.		
17. DISTRIBUTION STATEMENT (of the abstract entered in Block 20, if different from Report) N/A		
18. SUPPLEMENTARY NOTES The view, opinions, and/or findings contained in this report are those of the author(s) and should not be construed as an official Department of the Army position, policy, or decision, unless so designated by other documentation.		
19. KEY WORDS (Continue on reverse side if necessary and identify by block number) Composite Materials Graphite/Epoxy Mechanical Properties Thermal Effects Finite Element Analysis Moisture Effects Micromechanical Analysis S glass/Epoxy		
20. ABSTRACT (Continue on reverse side if necessary and identify by block number) Three major topics were pursued. The two-dimensional finite element micro-mechanics analysis was extended to include nonlinear viscoelastic material response. Analytical predictions of the time-dependent behavior of both glass/epoxy and graphite/epoxy unidirectional composites subjected to transverse compression were then correlated with experimental data also generated as part of this study. The viscoelastic properties of the epoxy matrix were also determined, as required input to the analysis. A new three-dimensional finite element analysis was developed,		

Unclassified

SECURITY CLASSIFICATION OF THIS PAGE (When Data Entered)

incorporating inelastic orthotropic material response, temperature- and moisture-dependent material properties, and improved numerical solution techniques. This analysis is permitting the study of both micromechanical and laminate problems.

Finally, an extensive experimental study of the transverse thermal expansion and moisture expansion properties of unidirectional glass/epoxy and graphite/epoxy composites was completed, along with a corresponding investigation of the neat (unreinforced) epoxy matrix. The finite element micromechanics analysis was then utilized to perform a sensitivity study of the various experimental parameters involved.

Unclassified

SECURITY CLASSIFICATION OF THIS PAGE (When Data Entered)

FORWARD

This Final Report summarizes research conducted during a three-year study performed under sponsorship of the U.S. Army Research Office, Durham, North Carolina, which was initiated in September 1979. The ARO Program Monitor during the first two and one-half years was Dr. John C. Hurt, Associate Director, Metallurgy and Materials Science Division. During the final six months, Dr. George Mayer, Director, Metallurgy and Materials Science Division, served as the Program Monitor.

Program Manager and Principal Investigator at the University of Wyoming was Dr. Donald F. Adams, Professor of Mechanical Engineering. Co-Principal Investigator was Mr. David E. Walrath, Staff Engineer, Composite Materials Research Group.

Graduate students making significant contributions included Mohammed M. Monib, Jayant M. Mahishi, Brent G. Schaffer, Douglas S. Cairns, Mark N. Irion, and Raja Mohan. Undergraduate students included Mark C. Siegfried, Lonnie A. Brown, Ronald W. Simon, Daniel S. Adams and John S. Huenefeld.



A

CONTENTS

<u>Section</u>	<u>Page</u>
1. SCOPE OF WORK	1
2. SUMMARY OF RESULTS	5
3. NONLINEAR VISCOELASTIC BEHAVIOR	6
4. THREE-DIMENSIONAL ELASTOPLASTIC FINITE ELEMENT ANALYSIS . . .	18
5. MOISTURE AND THERMAL EXPANSION OF COMPOSITE MATERIALS . . .	33
6. ABSTRACTS OF PUBLICATIONS OF RESULTS	47
6.1 Reports	47
6.2 Journal Publications	49
6.3 Published Conference Proceedings	50
6.4 Seminars and Presentations	52
7. PARTICIPATING SCIENTIFIC PERSONNEL	54
REFERENCES	56

SECTION 1

SCOPE OF WORK

The work performed as part of the current grant study was a logical extension of that initiated during the prior ARO grant [1]. It has long been recognized that there is a serious need for improved analysis methods for composite materials, and correlations of experimental and analytical results. In the prior study, emphasis was on the development of a basic micromechanics analysis [2-5]. A micromechanics analysis is defined in composite materials terminology as the study of local stress states in individual fibers and the surrounding matrix, and the prediction of unidirectional composite stiffness properties, thermal and moisture response properties, and the stress-strain response of the unidirectional composite subjected to mechanical loadings. Since relatively few polymer matrix material properties data were available, required as input to the micromechanics analysis, attempts were also made to experimentally determine these properties. A micromechanics analysis was successfully developed as part of this prior study, and subsequently utilized in a number of applications.

The present study extended this prior effort into several new areas. In particular, the basic micromechanics analysis was modified to include nonlinear viscoelastic response [6,7]. This analytical work was then correlated with some experimental creep test data generated as part of the current ARO grant also [8]. Concurrently, the basic micromechanics analysis was also extended to include longitudinal shear loading, funded by the Army Materials and Mechanics Research Center [9], and crack initiation and propagation, funded by NASA-Lewis Research

Center [10-14].

Having developed these micromechanics analysis capabilities, they were then utilized to study a number of aspects of composite material behavior of current interest [15-19]. In addition, the analytical/experimental correlations previously referred to were initiated [9,20-23]. Of course, much more remains to be done in this area, and additional work is currently in progress at Wyoming.

The micromechanics analyses have been used in analyzing a number of actual composite materials applications during the past several years, References [24-26] indicating just two of them. The various computer programs have been supplied, in tape format with complete user documentation, to several other universities, government groups such as the Army Materials and Mechanics Research Center and NASA-Lewis, and industry groups such as General Motors, Hercules, Hughes Aircraft, Vought Corporation, General Dynamics, Sperry, AMF-Head, North American Rockwell, and others. With this type of distribution, and the increasing awareness of micromechanics as a useful materials design tool, it is expected that the ARO-sponsored work at Wyoming will become a major contribution to composite materials technology during the next few years.

Based on the considerable success of the two-dimensional micromechanics analyses developed under ARO sponsorship, the decision was made to extend this work to a fully three-dimensional analysis. This major undertaking under the present ARO grant was first reported in late 1980 [27]. Work is continuing to refine the analysis and to increase its capabilities. In particular, the addition of improved input and output plot routines, a crack initiation and propagation capability, and fracture mechanics criteria are currently being

implemented. This three-dimensional analysis is useful both for micromechanics studies and laminate analysis, as well as the evaluation of simple structural components. An example of the latter application is our recent study of the thermal deformation of skis [28,29]. Sections of actual production skis were fabricated in our laboratory, tested, and the experimental results compared with the predictions of the 3-D analysis. The correlations were excellent. The analysis was also used in the study of ply drop-off effects in a recent Navy-sponsored program [30].

The experimental activities of the current ARO grant included the generation of unreinforced (neat) polymer matrix mechanical properties for use as input to the micromechanics analysis, as previously described, these data being presented in References [6,7,9,21] and elsewhere. In addition, a detailed study was conducted of the thermal and moisture expansion coefficients of both the neat resin matrix and glass/epoxy and graphite/epoxy unidirectional composites [22]. This has provided an excellent data base for future work. In addition, the two-dimensional micromechanics analysis was used to predict the thermal and moisture expansion coefficients of the two unidirectional composites, using the neat resin data as input, and the predictions were correlated with the measured values. Good correlations were obtained, the analysis also permitting the study of parametric variations of the various input material properties.

It was originally intended to perform fatigue tests on both glass/epoxy and graphite/epoxy composites also. However, a contract was received from the Naval Air Development Center (NADC) at about the same time, to do fatigue testing of the Hercules 3501-6 neat epoxy matrix

system [31]. This is the same epoxy system used in the current ARO study. This original one-year NADC contract was subsequently followed by a two-year additional contract, to study the fatigue response of other matrix materials also [32]. This work is presently being completed and a final report being written. Also, a contract was received from NASA-Langley to conduct fatigue tests on graphite/epoxy laminates. This work is now complete [33], and a follow-on effort is presently being negotiated. Thus, the proposed ARO fatigue study as originally proposed, was adequately covered in these efforts, permitting more concentration in the other areas previously described.

SECTION 2

SUMMARY OF RESULTS

The present study was very successful in meeting the originally stated objectives. Because the prior ARO grant had led to the development of a working micromechanics analysis, avenues for additional funding developed during the course of the current ARO effort, which permitted more work to be actually accomplished than was initially anticipated. As a result, at the conclusion of the current ARO grant, the two-dimensional micromechanics analysis is very well developed, and the three-dimensional analysis is a working tool. Sufficient experimental data have been generated for the epoxy matrix material, and other matrix materials, to provide input data which can be used with confidence. The number of applications in which these analyses have already been used has demonstrated their utility.

Since all of the work performed as part of the ARO grant has been fully documented in ARO Interim Reports, and also made available to the general public via journal publications, conference proceedings, and seminars, it is not necessary to present detailed results here, in this administrative final report. Only brief summaries will be given, with full reference to these published works.

SECTION 3

NONLINEAR VISCOELASTIC BEHAVIOR

Considerable controversy exists at present as to whether various polymer materials, and composites incorporating these polymers, exhibit linear or nonlinear viscoelasticity. The assumption of linear viscoelasticity leads to considerable simplification, but may not model actual response. Nonlinear viscoelasticity theory is not as well developed, but has the advantage of including linear response as a special case. It was decided to attempt to incorporate nonlinear viscoelasticity into the micromechanics analysis developed during the prior ARO study. If successful, this would provide a powerful tool for studying time-dependent material efforts in general, including creep, relaxation, and recovery phenomena.

The viscoelastic behavior of a composite material can be of paramount importance when the composite is subjected to repeated loading cycles or substantial loads at moderately high temperatures for long periods of time. Environmental cycling or fluctuations of the ambient temperature and/or relative humidity can also have considerable influence on the performance of the composite. Under such conditions, the internal stress distributions and overall strain of the composite could ultimately change enough with time to cause failure of the component. Alternatively, the stress state could also change so as to relieve high stress states in certain areas of the composite, preventing failure of the component.

In order to experimentally characterize the time-dependent behavior of a composite material, a number of tests must be conducted. There are

many factors (e.g., temperature, moisture, loading rate, and stress level) that affect the viscoelastic properties of a composite. Thus an extensive amount of testing must be undertaken to determine how and to what extent each of these factors will affect the composite. While a particular composite material system might be adequately characterized by such a testing program, if a designer wishes to use a different fiber-matrix combination, he must re-evaluate all the properties determined in the previous testing program. This can be a problem since there are numerous fiber-matrix combinations available to a designer.

To overcome this difficulty, the micromechanics analysis has been modified to include time-dependent effects. Since only the individual constituent properties need to be determined experimentally, this analysis becomes extremely cost-effective considering the amount of time and experimental testing saved by not having to evaluate all fiber-matrix combinations. Also, most fibers do not exhibit time-dependence. Therefore, only the candidate matrix materials need be tested. By inputting the appropriate constituent viscoelastic properties, the designer can try any combination of fiber and matrix material, to determine if that composite will satisfy his needs.

To model the various fiber-matrix combinations, the analysis uses a finite element model capable of simulating a unidirectional composite subjected to any combination of longitudinal and transverse normal loadings, as well as hygrothermal loading. Time-independent nonlinear (elastoplastic) material behavior is included, as is a creep formulation which uses stresses as the independent state variable. The analysis also contains two failure criteria, viz., an octahedral shear stress criterion and a hydrostatic criterion.

In the finite element analysis, nodal point forces are generated due to the creep strains. The magnitudes of these induced nodal forces are a function of the geometry of an element and the time-dependent material properties of that element. These node point forces thus must be calculated. By assuming the element stresses to remain constant throughout the time interval, and multiplying through by the time increment Δt , a linear approximation of the incremental creep strain for that time increment is obtained. For this reason it is necessary to keep the time increments, which are input into the analysis, very small when the value of the creep compliance is changing rapidly.

Once these incremental values of strain are known, the analysis solves for the incremental node point displacements, which are later used to find the new values for element stresses. When this has been accomplished, the solution procedure returns for the next increment of time, temperature, moisture, or load. Since an incremental procedure is used, to permit the linearization of material response within each increment (tangent modulus method), this also facilitates the combination of nonlinear viscoelastic and elastoplastic response. The time increments are selected to be sufficiently small so that the stresses within a given finite element can be assumed to remain essentially constant over the time increment. Adjustments of these stress values to maintain equilibrium conditions can then be made between time increments, using the governing elastoplastic (Prandtl-Reuss) flow rule. While obviously an approximation, it is of the same order as the incremental analysis itself, and consistent with the approximate nature of the finite element analysis. That is, the approximation can be improved as required by using smaller elements, smaller load increments, and smaller time increments.

The material properties for Hercules 3501-6 epoxy resin and S2 glass and Hercules AS graphite fibers were used in generating all of the numerical results. The assumed properties of the fibers were based upon available experimental data. Since the transverse properties of the fibers (i.e., E_t , ν_{rt} , ν_{tt} , α_t) are not well-characterized, their values were estimated based upon the existing literature. In all of the examples, the fibers were assumed to behave time-independently, i.e., to show no viscoelastic behavior.

A number of comparisons between the predictions of the present analysis and experimental results for various transverse compressive loadings of both glass/epoxy and graphite/epoxy were made. Two such comparisons are shown in Figures 1 and 2. Additional results are included in Reference [6]. It should be noted that the strain scale has been expanded to show detail, thus exaggerating the deviations between theory and experiment. Two predictions were actually made, one including a cure simulation and one without a cure simulation. The predictions with a cure, presented by the solid circles, involved simulating a cooldown from the 177°C cure temperature to room temperature (21°C). This was done using six time-independent temperature increments to achieve 21°C, and was followed by a 140-hour relaxation period. The relaxation time was arbitrary and was included in order to simulate what would happen to the stresses in a composite after it had been cured and allowed to "stand" for several hours. It was demonstrated that longer relaxation times tend to produce lower and more uniform stress states.

After this relaxation period, the load was applied and the composite allowed to creep. In examining Figures 1 and 2 it will be

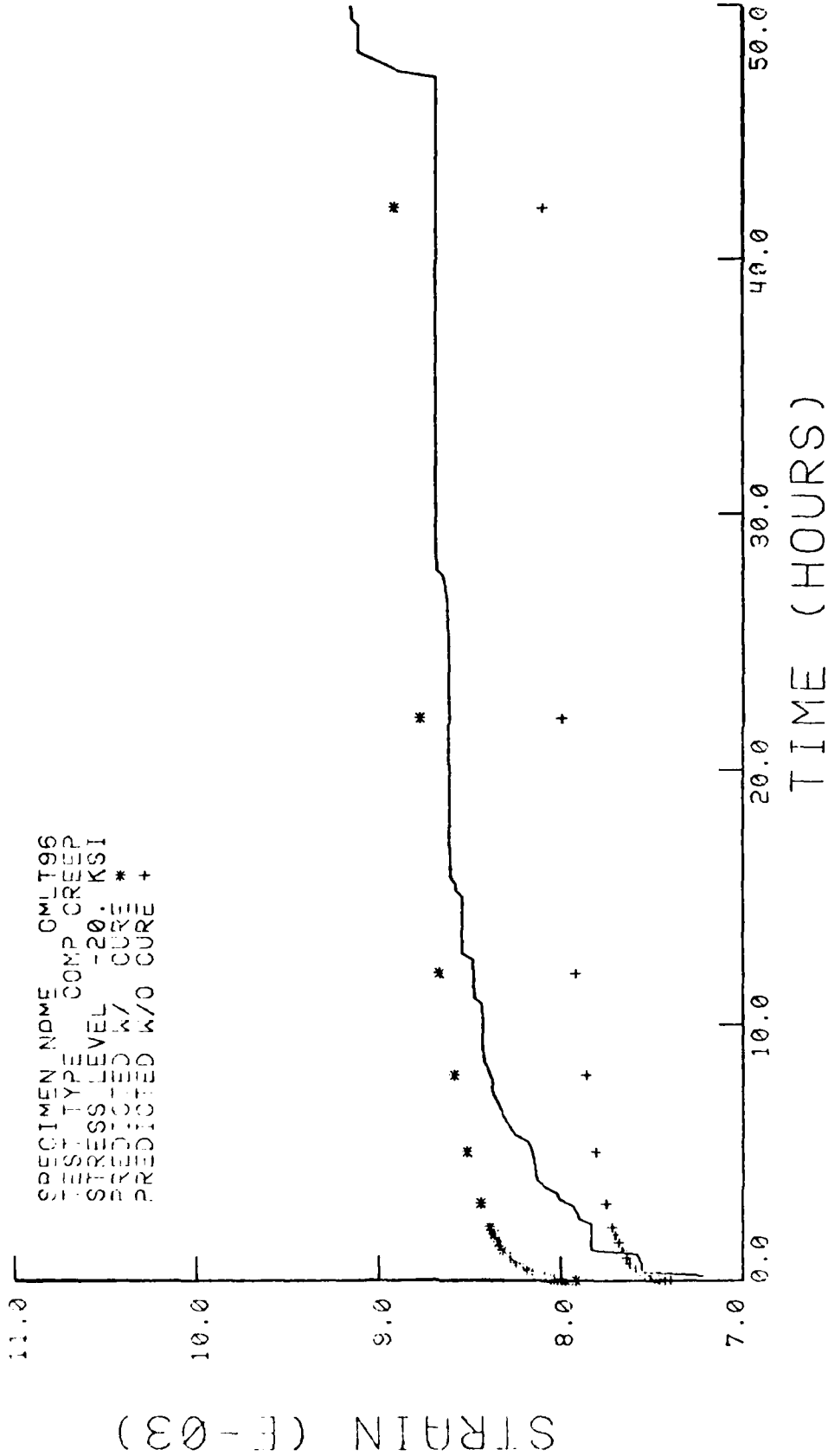

Figure 1. Plot of strain versus time for an S2 glass composite (using Hercules 3501-6 epoxy resin) subject to a 50 hour creep test. Predicted values are shown by the symbols while the solid line represents the experimental data [34].

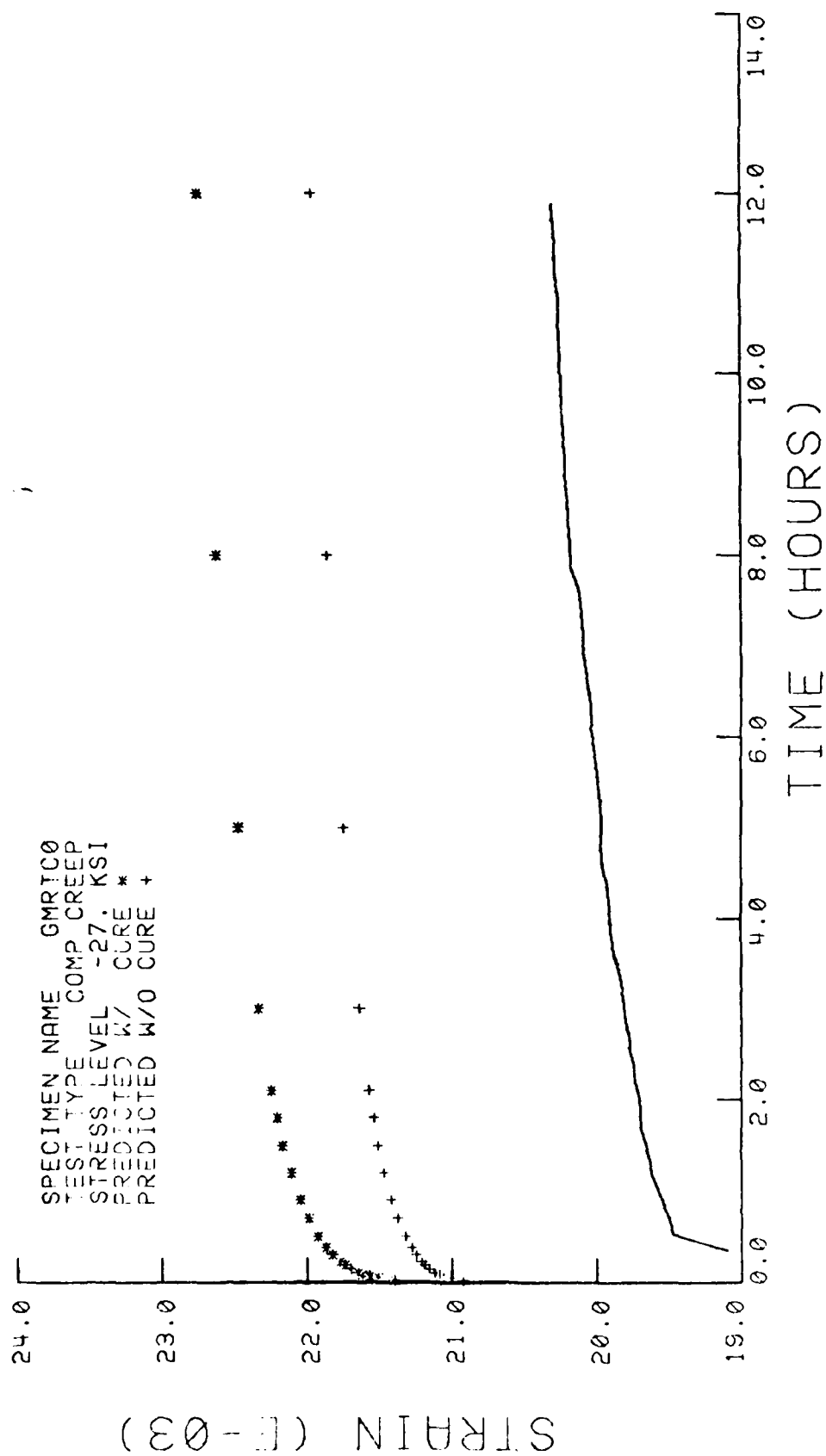

Figure 2. Plot of strain versus time for an AS graphite composite (using Hercules 3501-6 epoxy resin) subject to a 14 hour creep test. Predicted values are shown by the symbols while the solid line represents the experimental data [34].

noted that the creep strains for the simulation which involved a cure cycle are higher than those for the simulation which did not involve a cure cycle. The reason is that the initial internal stresses in an uncured composite are zero, while the internal stresses in the composite cooled from the cure temperature are very high. These initial stresses are caused primarily by the difference in the coefficients of thermal expansion between the fiber and the matrix.

Both "with" and "without cure" predictions were made in order to obtain a "range" in which the experimental data might lie. In other words, the subsequent response of a composite is a function of how long it has been since the specimen was fabricated. In theory, the internal stresses should be very small and uniform after a very long relaxation time. It is expected that the actual experimental data will lie somewhere within this range, and the predictions shown seem to confirm this. There is considerable scatter in the experimental data found in References [8,34]. The errors between the predictions and these experiments, as shown here in Figures 1 and 2, and in the additional comparisons in Reference [6], are of the same magnitude as the experimental scatter. Thus the agreement between the predictions and experiment is quite reasonable considering the limited amount of data available.

Stress contour plots for the composites are also of interest. Figures 3(a) and 3(b) show octahedral shear stress and strain contours immediately after cooldown of the glass/epoxy composite, while Figures 3(c) and 3(d) show the composite after 140 hours of relaxation. Figures 3(e) and 3(f) show octahedral shear stress and strain contours, respectively, for the composite just after application of a compressive

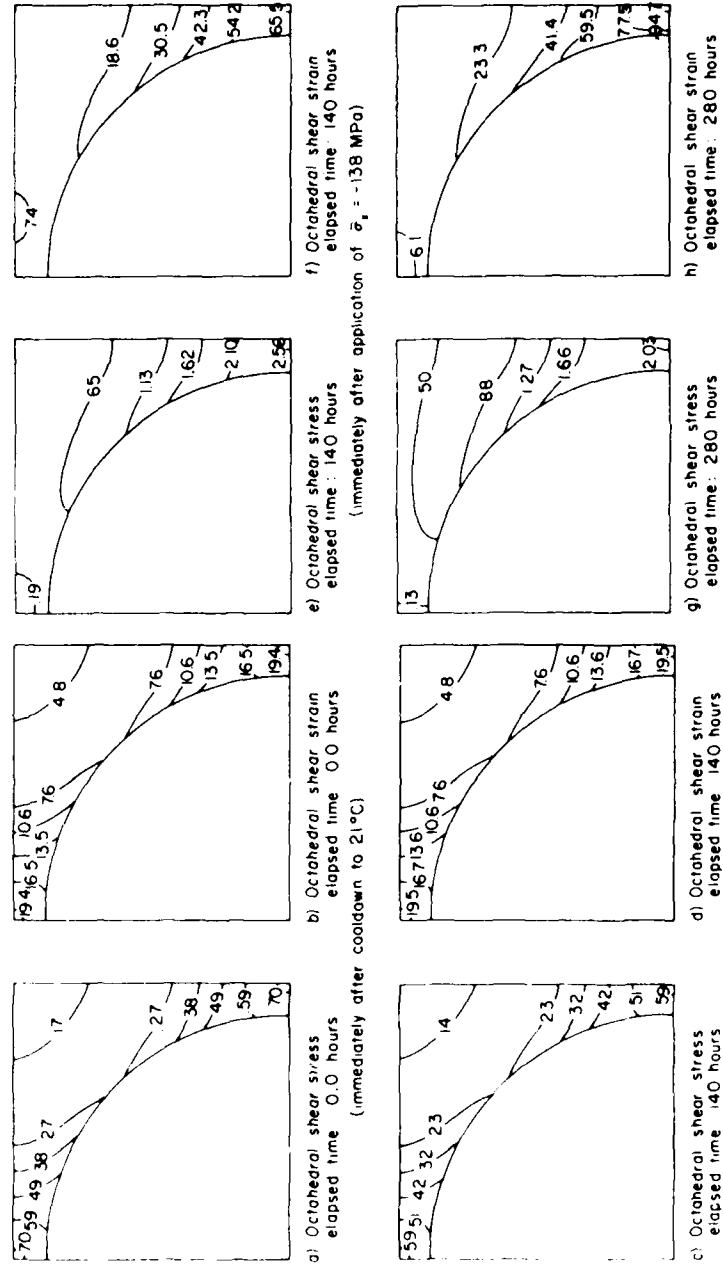

Figure 3. Octahedral shear stress (normalized) and octahedral shear strain plots for glass/epoxy subjected to a cooldown from the 177°C temperature to 21°C, followed by a 140 hr relaxation period, and then a -138 MPa (-20 ksi) stress for another 140 hr.

stress in the x-direction, and Figures 3(g) and 3(h) show these two plots for the composite after this stress has been applied for 140 hours. It will be noted that the octahedral shear stress plots for all of the following examples have been normalized by dividing by the yield value of the octahedral stress. Thus a contour value greater than one signifies that the region has yielded.

It is clear from Figures 3(a) and 3(c) that the internal stresses are relaxing from the cure cycle, as expected. It is also interesting to compare the contour values of the octahedral shear stresses in Figures 3(e) and 3(g). After 140 hours of elapsed time after application of the load, the high stress state in the lower right-hand corner has been relieved somewhat.

The octahedral shear strain plots, Figures 3(b) and 3(d), reveal only minute changes of the internal strain during relaxation, as exhibited by both the shapes and magnitudes of the contour lines. This is reasonable since a change in temperature creates a symmetric loading and the net force on the boundary due to this type of loading is zero. Figures 3(f) and 3(h) illustrate the change in octahedral shear strain immediately after the load has been applied, and 140 hours later. During this time the strain in the lower right-hand corner is seen to substantially increase, while only moderate increases in strain are observed for the upper portions of the model. These changes in strain are responsible for the redistribution of stresses during this time period.

In Figure 4, plots of the normal stress and tangential shear stress on the fiber-matrix interface are shown for the foregoing simulation, immediately after cure and immediately after application of the load.

Plots corresponding to 140 hours after cure and 140 hours after load application indicated significant reductions in both normal and shear stresses, as expected.

Figure 5 represents the glass/epoxy composite in which curing was not simulated. The first two plots are octahedral shear stress and octahedral shear strain contour plots for the instant immediately after application of the load, while the last two are for 140 hours after application of the load. Since the internal stresses are lower in this model than in the previous model (see Figures 3(e) and 3(g)), there is less redistribution of the stresses, as evidenced by Figures 5(a) and 5(c).

The octahedral shear strain (Figures 5(b) and 5(d)) is again seen to increase significantly in the lower right-hand corner (where the stress is high), with only moderate increases in the upper portion of the model. This is also caused by the lower initial stress state present in this composite than in the composite with the cure. Thus a higher stress state in a composite corresponds to a greater amount of creep strain, which in turn causes a greater redistribution of the stresses.

The single example just presented demonstrates only one of the many potential applications of the analysis. It is possible to simulate complicated loading histories, such as multiaxial cycling, thermal cycling, etc., to model many different situations. A number of additional examples, and comparisons with other experimental data, are included in Reference [6].

In summary, the analysis is capable of modeling any unidirectional composite subjected to longitudinal and/or transverse normal and/or

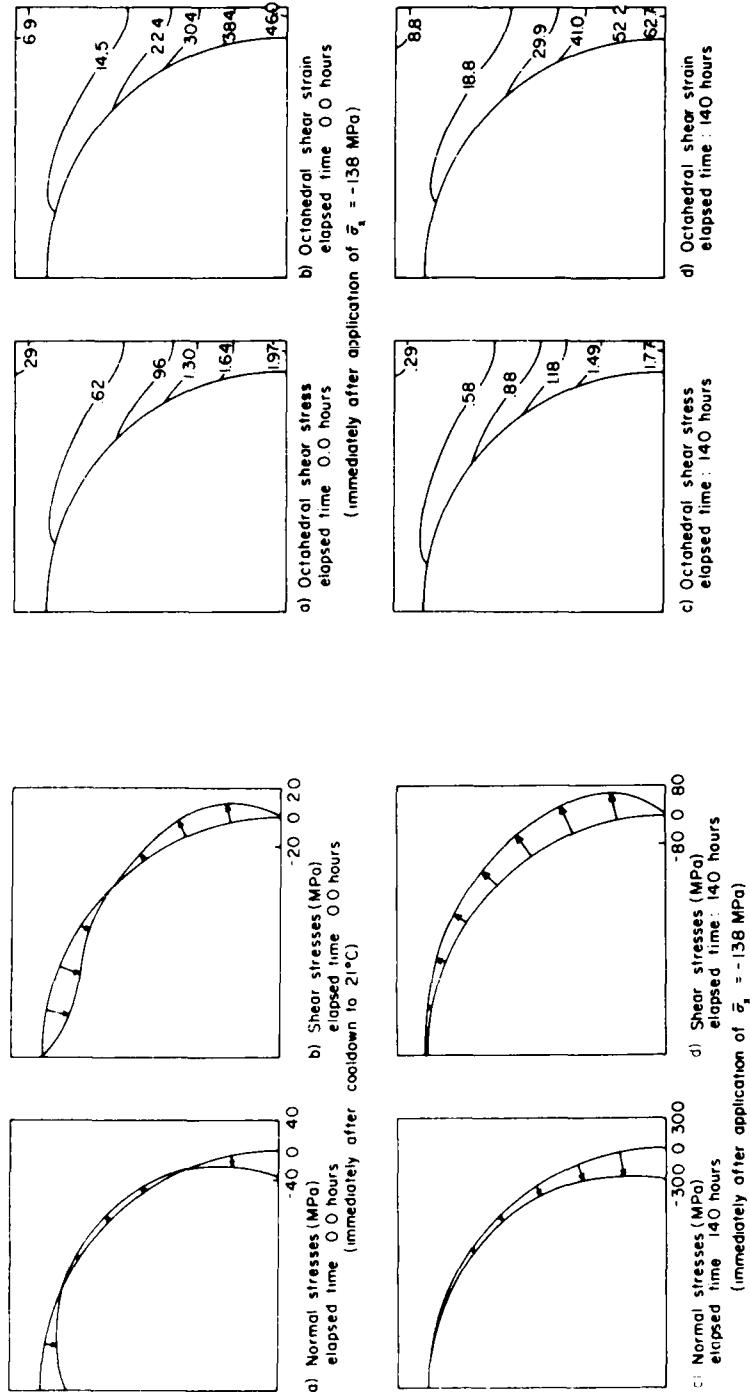

Figure 4. Interface stresses for glass/epoxy subjected to a cooldown from the 177°C cure temperature to 21°C followed by a 140 hr relaxation period, and then a -138 MPa (-20 ksi) stress.

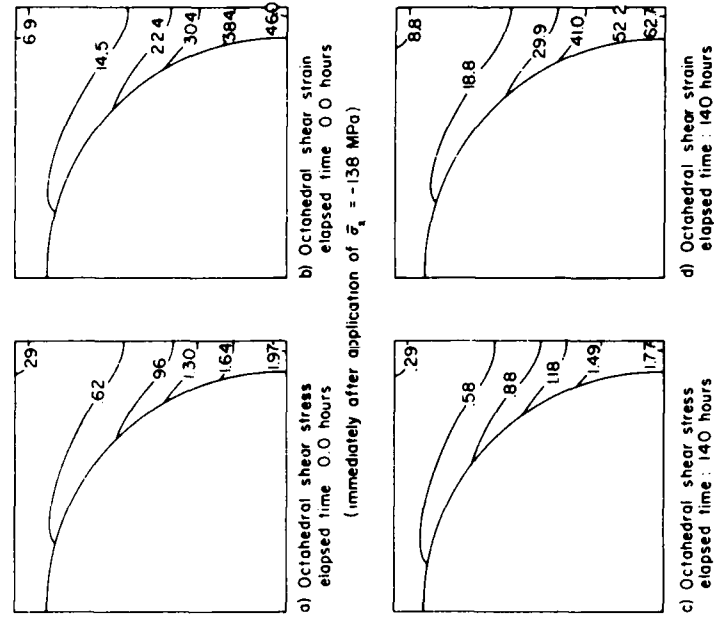

Figure 5. Octahedral shear stress (normalized) and octahedral shear strain plots for glass/epoxy subjected to a -138 MPa (-20 ksi) stress for 140 hr (no prior temperature history)

hygrothermal loadings. It solves problems which involve changes of stress, temperature, and moisture content with time as a series of step loadings. That is, no increments of load, temperature, or moisture are permitted during a time increment. However, increments of load, temperature, and/or moisture may be applied simultaneously using a time-independent increment.

The nonlinear viscoelastic parameters for the matrix material which are input to the analysis can be determined by means of a series of creep-recovery tests at different stress levels, as demonstrated in Reference [6]. To include the effects of temperature and moisture, a series of creep-recovery tests at various temperatures and moisture contents must be run. An important feature of the present analysis is that only constituent material properties need to be evaluated. This avoids the difficulty of having to evaluate the time-dependent parameters of all fiber-matrix combinations. Usually only matrix materials need to be tested for time-dependence since most fibers do not show (or show very little) viscoelastic behavior. Thus a designer can model the time-dependent behavior of many different types of composite systems with only a small amount of experimental data.

In general, the results obtained for uniaxial loading compare very well with the experimental data available. Comparisons with the data generated by Irion [8,34] proved the analysis to be within experimental error. While only a limited amount of data was available for comparison, it is felt that future comparisons will be equally accurate.

SECTION 4

THREE-DIMENSIONAL ELASTOPLASTIC FINITE ELEMENT ANALYSIS

Until very recently, almost all studies of the response of composite materials, whether at the micromechanical or the macromechanical level, have utilized two-dimensional analyses. In many cases, such as the prior micromechanical analysis outlined in the prior two sections, this has not been a major limitation, the physical problem being studied being essentially two-dimensional in nature. However, in the other cases, the restriction to a two-dimensional analysis has forced very severe assumptions to be made. One example is our own work reported in References [10,11].

Thus, one important goal of the present study was to extend the existing two-dimensional finite element analyses to three dimensions. The result was a completely new analysis and related computer program [27], in which several relatively new numerical analysis techniques were also incorporated. These included, in particular, reduced integration and a frontal solution technique.

While the principles of three-dimensional elastic stress analysis by the finite element method have been obvious from the early days of the development of the method, their practical implementation leads to some immediate obstacles. As the number of elements increases, so do the number of degrees of freedom, increasing the size of the stiffness matrix, which requires larger computer in-core storage. In early approaches to three-dimensional analyses, the simple tetrahedral element was the obvious choice [35,36]. However, it was soon realized that, although convergence to the exact solution is guaranteed as the number

of elements is increased, it was too slow for problems of even moderate size. While the tetrahedron has certain advantages in its formulation, it is nevertheless an inconvenient shape to deal with in grid generating, i.e., topologically, and usually several have to be combined to form easily managed hexahedral shapes. Various families of isoparametric elements were introduced by Zienkiewicz, et. al., in 1967 [37]. These elements are more efficient than tetrahedrons, and have been utilized in the present analysis, thus allowing a greater accuracy to be achieved for a given number of degrees of freedom and given computation time.

A modular approach was adopted in the present work, with the various main finite element operations being performed by separate subroutines. Figure 6 shows the organization of the program. The basic finite element steps are performed by primary subroutines, which rely on auxiliary subroutines to carry out secondary operations. The construction falls into three phases.

Phase 1. Data are input and checked for possible preparation errors, an important feature when considering the amount of data input required for three-dimensional problems.

Phase 2. Stiffness and stress matrices and the applied load vector are generated. The nature of laminated composite problems requires elements with large aspect ratios, i.e., the ratio between minimum and maximum characteristic dimensions of an element in the mesh. This is because the thickness of a lamina is typically very small compared to the off-diagonal terms, a situation that can lead to large solution errors. However, by using reduced integration techniques [38] the problem can be overcome.

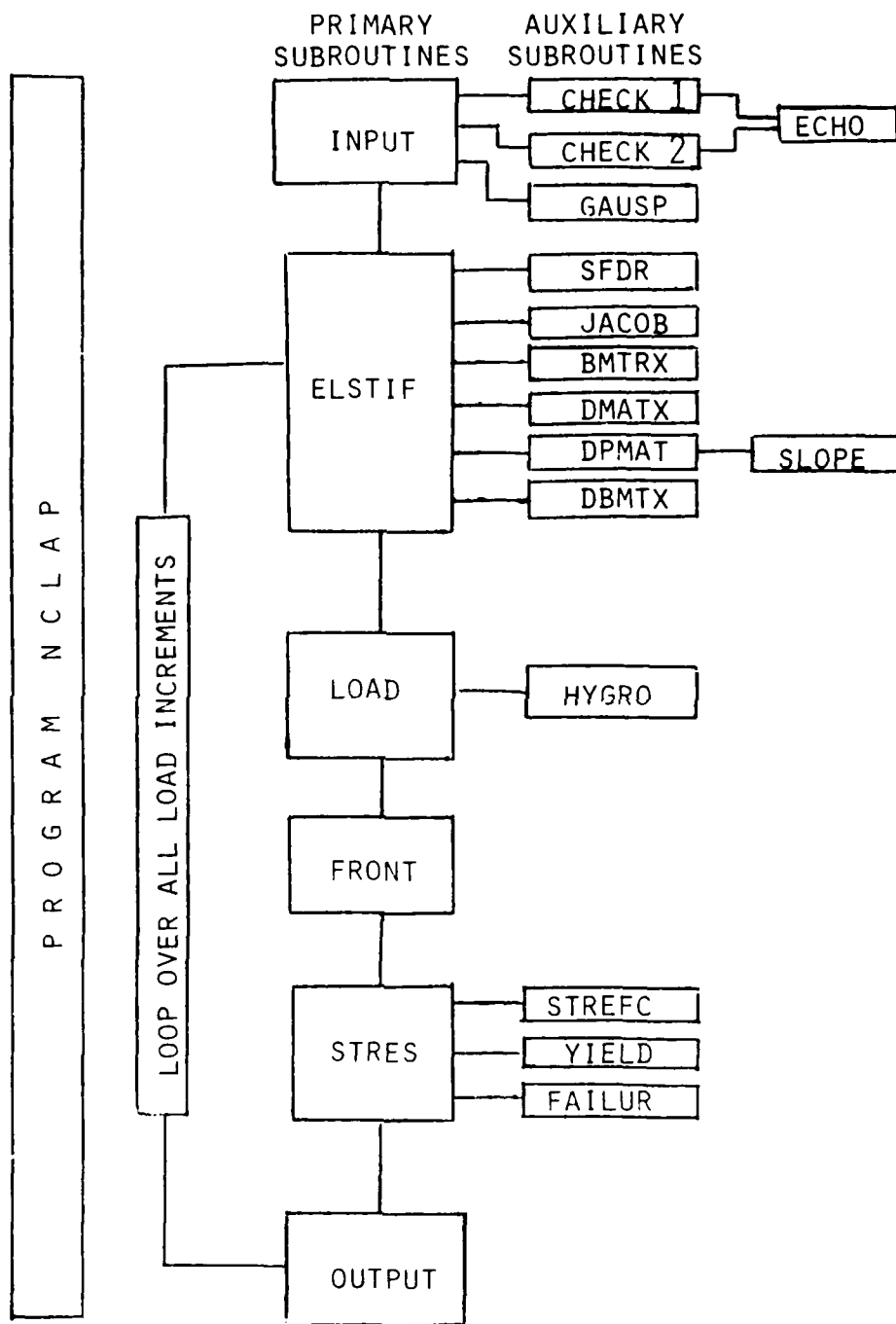

Figure 6. Organization Chart for the Three-Dimensional Finite Element Computer Program.

Phase 3. A 'frontal' solution technique [39,40] is used for the solution of the stiffness equations. The advantages of using this method rather than the well-known banded matrix method are:

- 1) In solving the stiffness equations using a banded matrix, the order in which the nodes are numbered is very important since it influences the bandwidth. Using the frontal solution technique, however, does not require any ordering of nodal numbers. Hence, if a mesh is to be modified at a later time, no renumbering is needed. This saves considerable time and effort in data preparation.
- 2) For higher order elements, less core storage is needed. Several examples which justify this statement can be found in Reference [41].
- 3) Since variables are eliminated in this method as soon as conceivably possible, operations on zero coefficients are minimized and the total number of arithmetic operations is less than with other methods. Thus, less storage and computer time is used.
- 4) Because any new equation occupies the first available space in the front, there is no need for a bodily shifting of the in-core equations as in many other large capacity equation solvers.

In any incremental analysis, the use of smaller load increments implies a larger number of increments to achieve the same total applied load. Hence, more time is spent in reconstructing stiffness equations. A main feature of the computer program developed in the present study is that it allows for the use of small load increments without increasing

the computing time significantly. The stiffness matrix is reconstructed only for those elements that become plastic, or when hygrothermal loading is considered.

The method of analysis presented in this work, together with the computer program developed for its implementation, can be applied to a very wide range of problems. Reference [27] illustrates a few of these possible applications. The solutions to four different problems are presented there, using the analysis and, whenever possible, including comparisons with results obtained using other methods. These four problems cover the areas of generally orthotropic laminated beams and plates in bending, free edge effects in laminated plates, and the problems associated with these edge effects around circular holes. Both mechanical and hygrothermal loadings are considered, as well as nonlinear material effects. Just one example will be included here.

The presence of interlaminar stresses near the free edges of laminated plates is demonstrated in Reference [27]. A more complicated and interesting type of problem is that of interlaminar stresses around cutouts, e.g., holes, in laminated composites. Such problems, involving curved rather than straight boundaries, are generally more difficult to analyze. However, since the present analysis is a three-dimensional finite element approach, it is capable of handling any type of boundary geometry with similar ease. The laminates included in this example will be analyzed first under a uniaxial strain ($\bar{\epsilon}_x = 0.01$ percent) in order to compare results with results using other methods. The multiaxial loading capability will then be demonstrated by applying biaxial loading to the laminates. Finally, inelastic response will be considered. Other methods in the literature cannot handle cases other than uniaxial

loading, since they are based on the uniaxial displacement field first introduced by Pipes and Pagano [42], and few earlier analyses considered nonlinear material behavior.

Four-ply laminates of the configurations $[0/90]_S$ and $[90/0]_S$, containing circular holes, are considered. The overall dimensions of the laminate, as given in Reference [43] are:

Length, $l = 203$ mm

Width, $w = 254$ mm

Ply thickness, $h = 7.6$ mm

Hole radius, $R = 6.25$ mm

The three-dimensional grid used is shown in Figure 7; only one quarter of the upper two layers need be considered, because of symmetry. In the first part of this example, for purposes of comparison, the material assumed is the unidirectional graphite/epoxy composite used in Reference [43], the mechanical properties of which are:

$$E_{11} = 206 \text{ GPa (30 Msi)}$$

$$E_{22} = E_{33} = 20.7 \text{ GPa (3 Msi)}$$

$$G_{23} = G_{31} = G_{12} = 6.9 \text{ GPa (1 Msi)}$$

$$\nu_{23} = \nu_{31} = \nu_{12} = 0.336$$

The distribution of the interlaminar normal stress σ_z is shown in Figure 8 for the two configurations, viz, $[0/90]_S$ and $[90/0]_S$, under a uniaxial strain $\bar{\epsilon}_x = 0.01$ percent, corresponding to an average applied stress $\bar{\sigma}_x = 7.1$ MPa. Both laminate configurations show a compressive

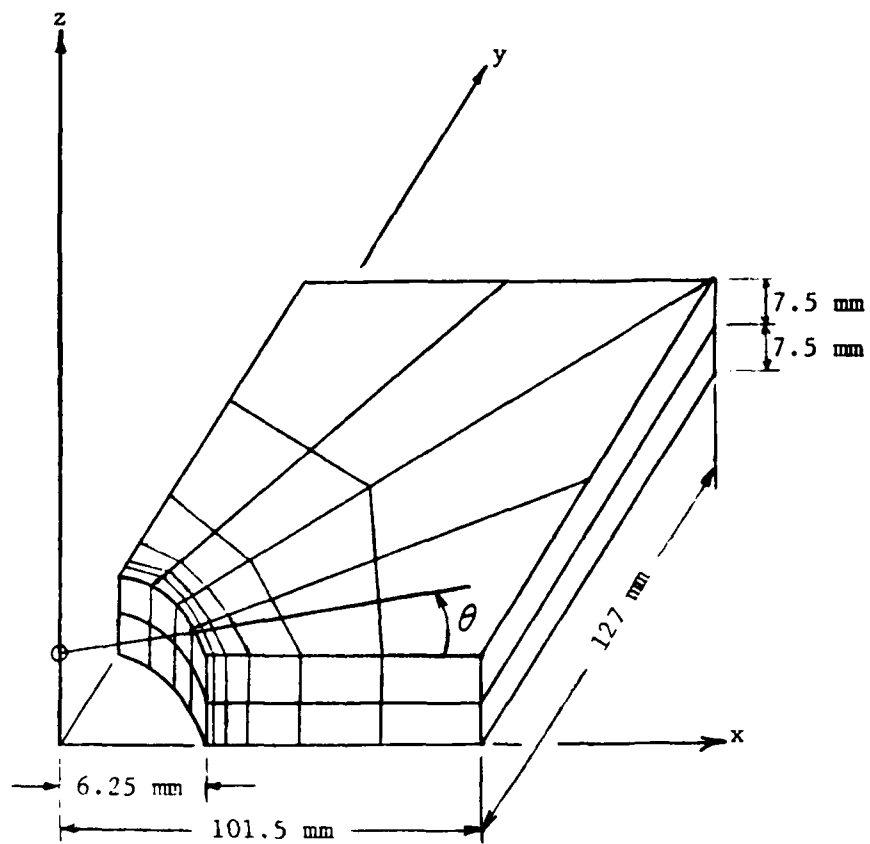

Figure 7. Finite Element Grid Used to Model a Circular Hole in a Four-Ply Laminate.

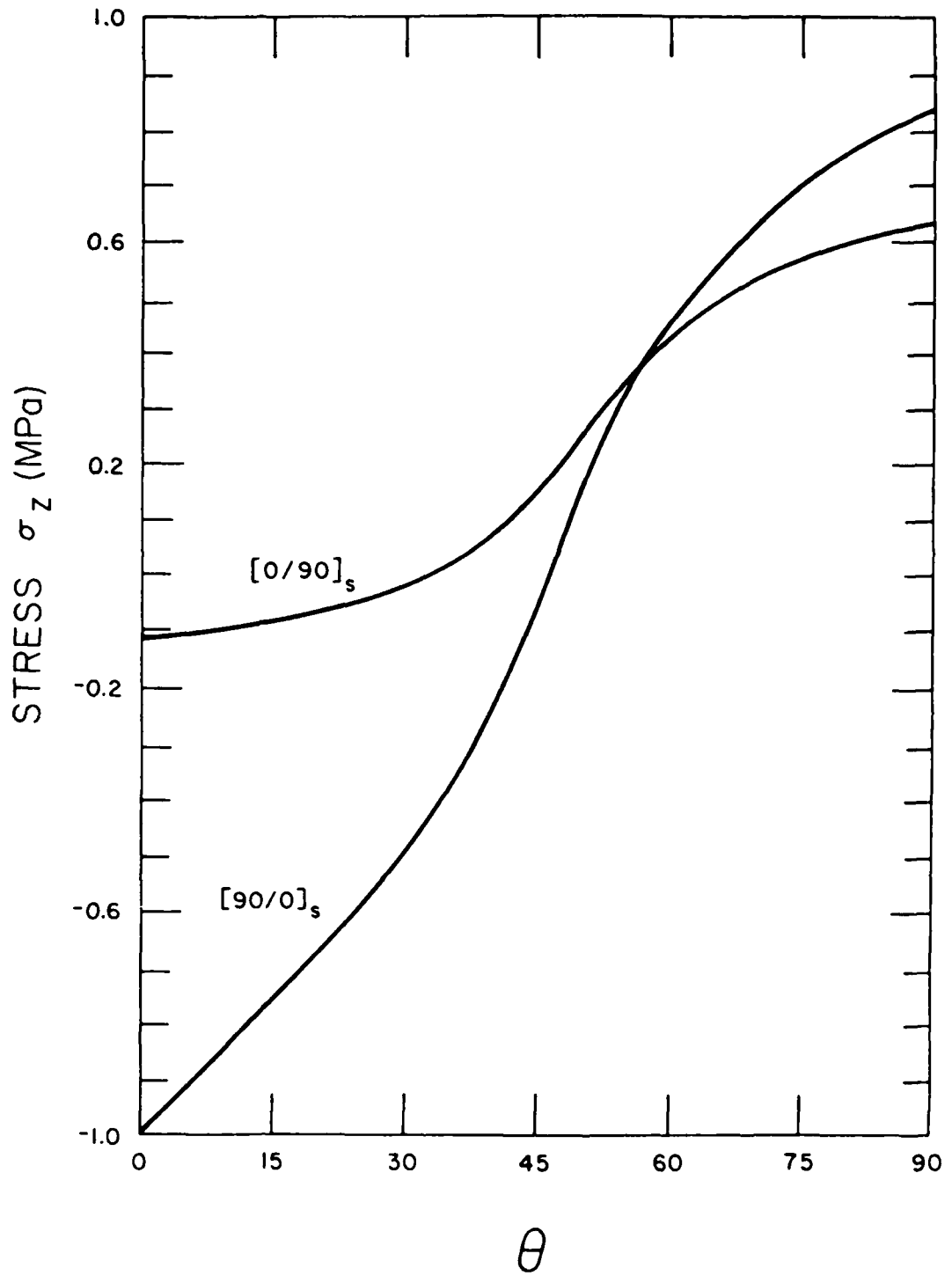

Figure 8. Interlaminar Normal Stress versus Position Around the Free Edge of a Hole in Two Cross-Ply Laminates.

value for σ_z at $\theta = 0^\circ$, and a tensile value at $\theta = 90^\circ$. Higher values at $\theta = 0^\circ$ and 90° are observed in the $[90/0]_S$ laminate. Thus, the change in stacking sequence does not produce mirror image distributions. Also, in contradiction with results reported in Reference [43], the interlaminar normal stress near the free edge of the hole does not change sign as the stacking sequence is changed.

The analyses of composite laminates under uniaxial loading are helpful in understanding the complex behavior of interlaminar stresses. In actual service, however, laminates are often subjected to multiaxial states of stress. The second part of this example illustrates the capability of the present analysis to handle multiaxial loading situations. Laminates with circular holes, previously analyzed under uniaxial loading, are considered next under varying biaxial loadings.

Table 1 shows the interlaminar normal stress at two different locations, viz, $\theta = 0^\circ$ and $\theta = 90^\circ$, under different biaxial loading conditions. This table has been generated by varying the ratio of $\bar{\epsilon}_x / \bar{\epsilon}_y$. For the $[90/0]_S$ laminate, σ_z is always positive at $\theta = 90^\circ$, with almost the same value. This value, shown in column four in Table 1, is reached rapidly from zero under $\bar{\epsilon}_x / \bar{\epsilon}_y = 0$, and then attains a constant value at about $\bar{\epsilon}_x / \bar{\epsilon}_y = 1$. Plate dimensions and Poisson's ratios appear to affect this behavior; further investigations are needed to fully understand this response. At $\theta = 0^\circ$, σ_z changes from tension to compression as $\bar{\epsilon}_x$ is increased relative to $\bar{\epsilon}_y$. For the $[0/90]_S$ configuration, the interlaminar normal stress is always positive at $\theta = 0^\circ$, but the value decreases as the ratio $\bar{\epsilon}_x / \bar{\epsilon}_y$ increases. At $\theta = 0^\circ$, σ_z increases from compression to tension as $\bar{\epsilon}_x / \bar{\epsilon}_y$ increases. Predictions such as those given in Table 1 should be very useful to the designer

since by estimating the value of $\bar{\epsilon}_x/\bar{\epsilon}_y$, a suitable layup can be chosen.

Table 1.

Interlaminar Normal Stresses at Two Midplane Locations Around
the Free Edge of a Circular Hole in Cross-Ply Laminates.

Ratio of Applied Strains $\bar{\epsilon}_x/\bar{\epsilon}_y$	Interlaminar Normal Stress σ_z (MPa)			
	[0/90] _s		[90/0] _s	
	$\theta = 0^\circ$	$\theta = 90^\circ$	$\theta = 0^\circ$	$\theta = 90^\circ$
0.125	4.0	-3.5	2.0	0.4
0.25	2.0	-2.0	0.7	0.4
0.3	1.7	-1.3	0.5	0.4
0.6	0.6	-0.5	0.03	0.4
1.25	0.4	-0.1	-0.2	0.4
1.5	0.3	-0.03	-0.3	0.4
3	0.15	0.12	-0.4	0.4
5	0.08	0.20	-0.4	0.4
6	0.06	0.20	-0.4	0.4

In spite of the fact that composite materials may exhibit large amounts of inelastic deformation, no analysis has considered the inelastic behavior of composite laminates. To show how the present analysis can handle inelastic material behavior, a different material system is used in the next part of this example. The material is Hercules AS/3501-6 graphite/epoxy, the extensive mechanical properties of which are given in Reference [27]. The method of analysis of Reference [43] did not consider inelastic behavior, and hence no post-elastic properties were presented.

The interlaminar stresses for the two cross-ply configurations are calculated under a biaxial loading ratio $\bar{\epsilon}_x/\bar{\epsilon}_y = 1.25$ (see Table 1). Figure 9 is a plot of the interlaminar stresses at the midplane, i.e., at $z = 0$, while the interlaminar stresses at the interface between the 90° and 0° plies, i.e., at $z = h$, are shown Figure 10. For both configurations, the interlaminar normal stress σ_z is dominant at $\theta = 90^\circ$, with a higher tensile value in the $[90/0]_s$ laminate. The variation of σ_z between $\theta = 0^\circ$ and $\theta = 90^\circ$ is much greater at the midplane than at $z = h$. The interlaminar shear stress τ_{yz} at $z = 0$ increases in absolute value to a maximum at $\theta = 90^\circ$ for both configurations. However, at $z = h$, a peak absolute value is attained at $\theta = 45^\circ$. The interlaminar shear stress τ_{zx} behaves in a similar manner at $z = h$, except for a change in sign, and also attains a peak value at $\theta = 45^\circ$. However, at $z = 0$, τ_{zx} decreases in absolute value towards a minimum at $\theta = 90^\circ$.

To study the inelastic behavior of cross-ply laminates, the biaxial loading was increased, keeping the ratio constant. In the case of the $[0/90]_s$ laminate, yielding occurred first at the free edge of the hole in the inner 90° ply at an angle slightly less than 45° , and in the outer 0° ply at an angle slightly greater than 45° , as indicated in Figure 11. As the load increased, the yield zone moved across the 45° line in both plies, always beginning in the inner ply, i.e., the 90° ply. Yielding in the $[90/0]_s$ laminate started at the same locations and at the same load level. The progressive growth of the yield zone in each lamina for both configurations is shown in Figure 11. The pattern in which the plastic zone propagated in each ply did not change as the stacking sequence changed. First failure was found to occur at the 45° position. For both configurations, this first failure was at the free edge of the hole, at the midplane. The state of stress around the free

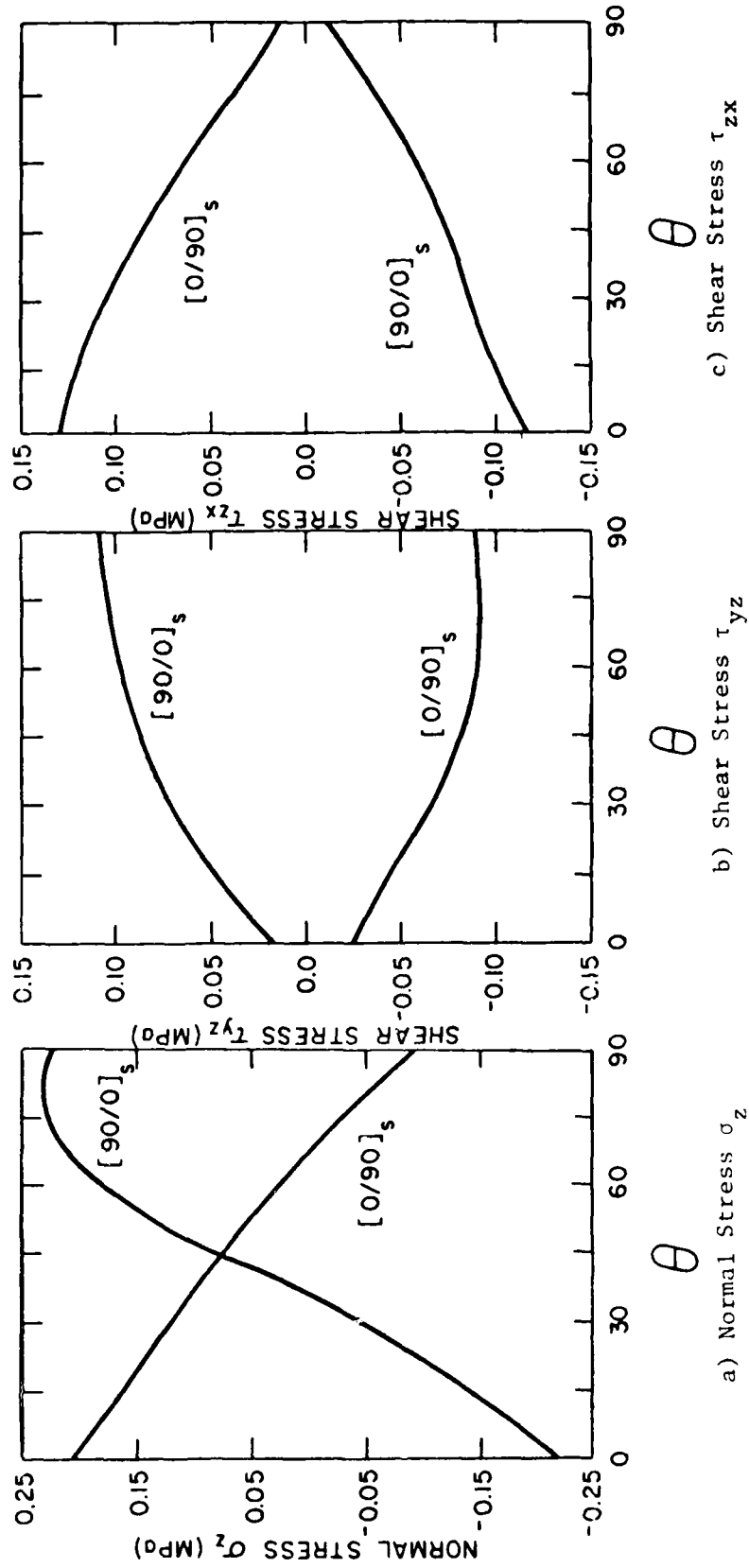

Figure 9. Interlaminar Stresses Around a Circular Hole at the Midplane, $z = 0$, in $[0/90]_s$ and $[90/0]_s$ Laminates Subjected to the Biaxial Loading $\bar{\epsilon}_x/\bar{\epsilon}_y = 1.25$.

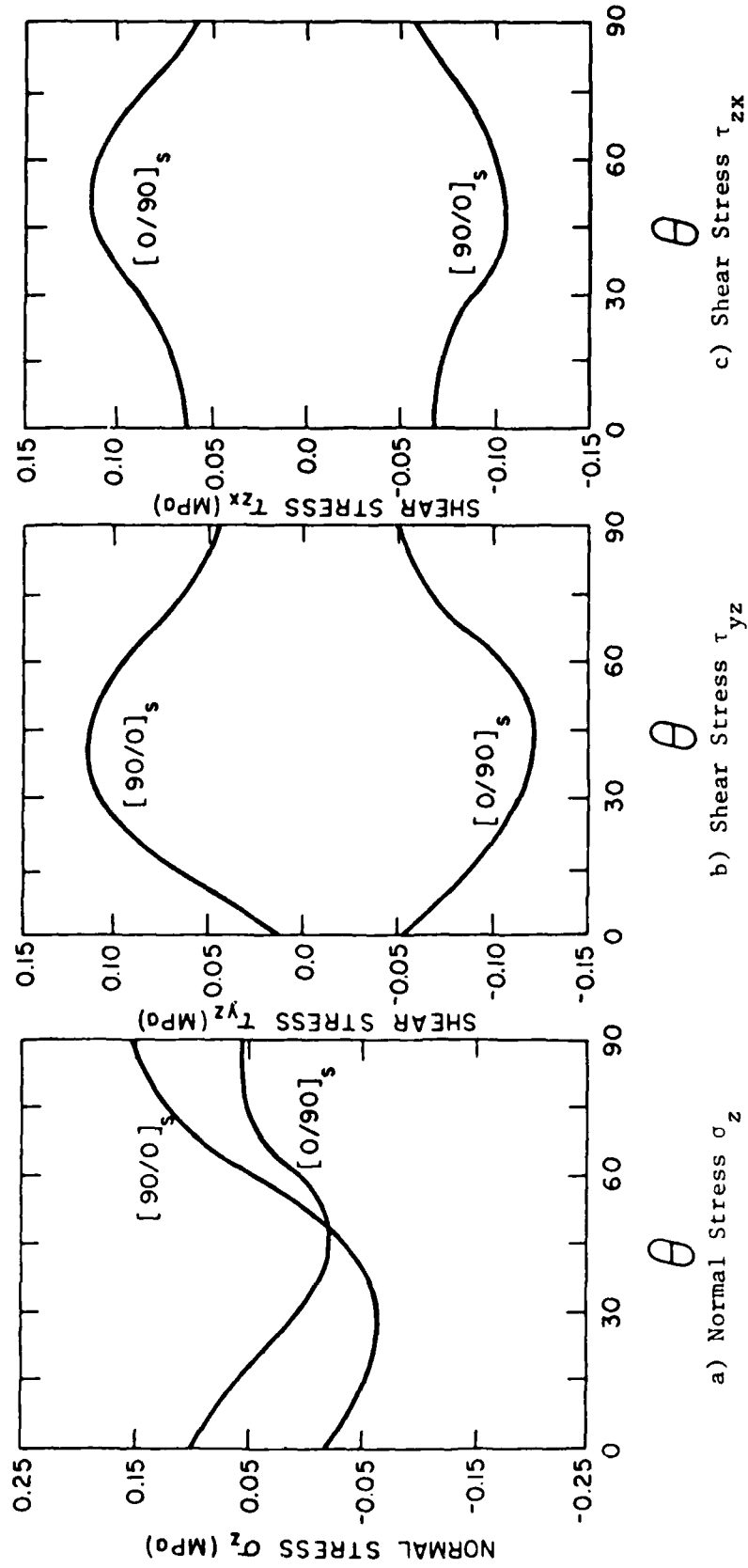
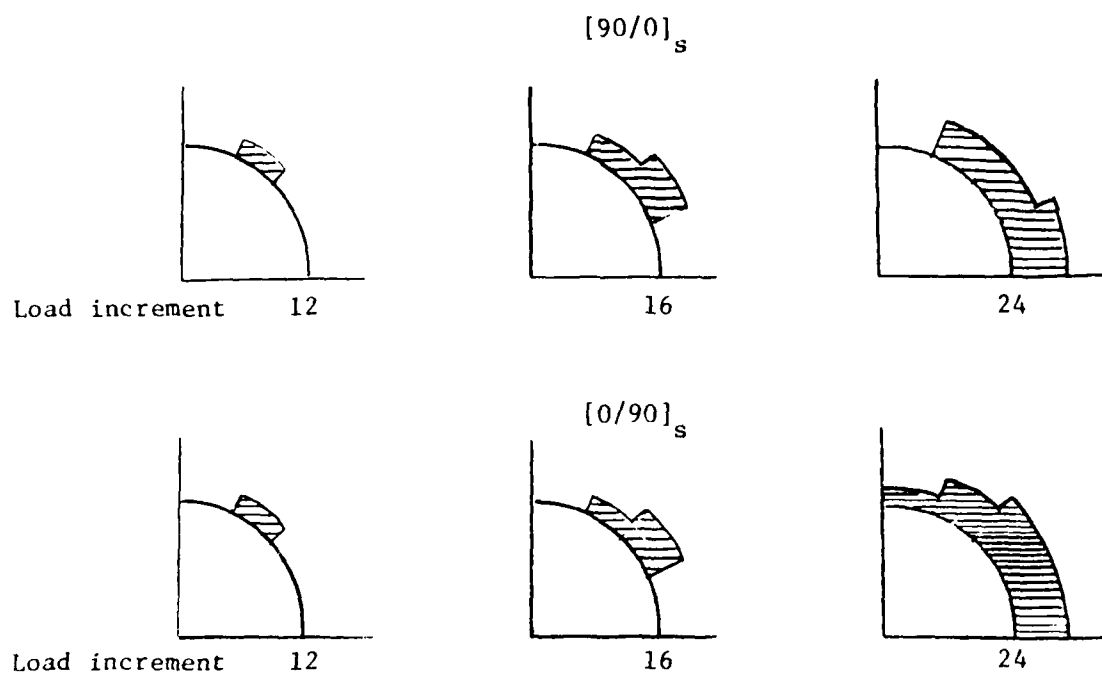
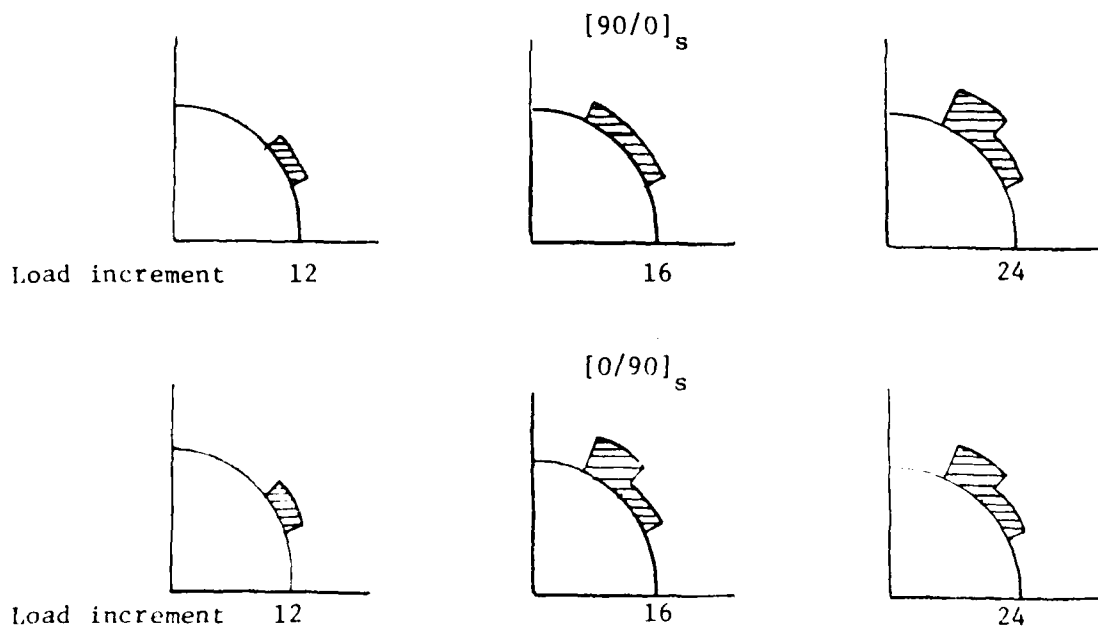

Figure 10. Interlaminar Stresses Around a Circular Hole at $z = h$, in $[0/90]_s$ and $[90/0]_s$ Laminates Subjected to the Biaxial Loading $\epsilon_x/\epsilon_y = 1.25$.



a) Propagation of yield zone in 0° ply



b) Propagation of yield zone in 90° ply

Figure 11. Propagation of Yield Zone under the Biaxial Loading
 $\bar{\epsilon}_x / \bar{\epsilon}_y = 1.25$.

edge of cutouts is indeed very complicated. A method of analysis such as the one presented here is mandatory when designing laminates that will not delaminate at free edges, whether at a straight free edge or around a cutout. The ability of this method to handle hygrothermal loadings makes it of special value in dealing with polymeric composites, which are specially susceptible to changes in temperature and moisture levels. Such changes in environmental conditions often lead to triaxial states of stress, which can only be handled by a full three-dimensional analysis.

SECTION 5

MOISTURE AND THERMAL EXPANSION OF COMPOSITE MATERIALS

Composite materials have been developed extensively for use in structural components. A composite material typically consists of a load-carrying material phase, such as fibers, held together by a binder or matrix material, often a polymer. However, matrix materials typically exhibit drastically different coefficients of thermal expansion than fibers, and high performance composites typically are cured at elevated temperatures. At the cure temperature, the matrix and fiber can usually be considered to be at a zero stress state. When the composite is cooled to room temperature, the mismatch of thermal expansion coefficients induces stresses. The matrix material may actually be forced into the plastic region, causing permanent deformation of the composite.

The coefficient of thermal expansion is usually higher in the transverse direction than the longitudinal direction of a unidirectional lamina. This is due to the fact that the fibers do not restrict matrix expansion in the transverse direction as much as in the longitudinal direction. Stresses are hence generated in the laminate. A composite can actually fail due to these thermally-induced stresses, even though no mechanical loads have been applied. Thus, these thermal stresses must be considered in design and analysis. Another design consideration is dimensional stability. For example, graphite fibers actually have a slightly negative coefficient of thermal expansion in their longitudinal direction, while polymer matrix materials have a positive coefficient of thermal expansion. By combining these materials in the proper ratio, a

composite may be obtained which has virtually a zero coefficient of thermal expansion.

A similar problem of dimensional stability is posed by the absorption of moisture into the matrix material. Polymers currently used as matrices in composites absorb moisture, while fibers such as glass and graphite absorb little or none. As moisture diffuses into the matrix, expansion occurs. This expansion again causes internal stresses along with dimensional changes. The moisture-induced dimensional change in the transverse direction of a unidirectional lamina is greater than the dimensional change in the longitudinal direction, since the stiff fibers restrict this change. The same laminate design problems mentioned for thermal expansion exist due to moisture expansion also.

In light of the above, it is necessary to determine the nature of moisture and thermal expansion of a unidirectional lamina prior to any design. The matrix material as well as the resulting laminae need to be characterized, so that not only may reliable data for individual laminae be obtained, but predictions based on material constituent properties be formulated also.

Since little has been done to date to determine the moisture expansion coefficients of unidirectional composite materials, the main thrust of the present study was to characterize a typical matrix material, and two composites with very different fiber materials, but with this same matrix. Since the Hercules AS/3501-6 graphite/epoxy composite system is widely used and was readily available, as was the Hercules 3501-6 epoxy resin system, these materials were chosen for the study. Owens-Corning S2 glass fiber in the same Hercules 3501-6 epoxy matrix was chosen as the third material system.

These three materials were also used for the thermal expansion tests since analysis of both the moisture dilatation and thermal dilatation is similar. One goal of the present study was, knowing the mechanical and physical property characteristics of both the matrix material and fiber, to be able to predict the properties of a lamina. Using these unidirectional ply properties, a composite laminate may be analyzed, using existing laminate analyses.

Producing thin neat resin plates free of all voids, foreign matter, and surface imperfections is difficult, especially for the high volatile content, viscous, hot melt resin systems such as the Hercules 3501-6 epoxy. However, special techniques have been developed at the University of Wyoming as part of the present ARO study for casting the high temperature cure matrix systems used in advanced composites. These techniques include open mold casting, and casting in elastomer molds having a coefficient of thermal expansion compatible with the resin system being cast.

The graphite/epoxy specimens were fabricated from commercially available, 305 mm (12 in) wide Hercules AS/3501-6 prepreg tape. No prepreg of the S2 glass fiber and 3501-6 epoxy resin was available; this had to be fabricated.

Three Blue M Stabiltherm Model OV-U60A Gravity Ovens were used to provide heat for the accelerated moisture conditioning. Each oven contains a semi-vaporproof insert made of Plexiglas to provide a chamber for the moisture conditioning. The chambers are not totally vaporproof since holes for instrumentation allow some water vapor to escape. Housed inside the chambers are the quartz glass dilatation measuring assemblies and the specimens used for determining weight gain

and diffusivity constants. The ovens may be used with distilled water to obtain 98 percent relative humidity, or saturated salt baths to provide a controlled moisture environment at lower relative humidities.

On the outside of the ovens are Daytronic Model DS200 LVDTs (Linear Variable Differential Transformers), with calibration assemblies, used to monitor the dilatation of the specimens via a quartz glass pushrod. The external mounting is desirable since the LVDTs are not particularly well-suited for the high temperature, high humidity environment present inside the chambers. The LVDTs are repeatable to ± 0.00015 mm (± 0.000006 in) according to specifications. A Daytronic Model 9130 LVDT conditioner provides a linear $\pm 5V$ DC output to a microcomputer analog-to-digital (A/D) converter. The extension measuring system is accurate to ± 0.00254 mm (± 0.0001 in) with 0.1 percent error. This accuracy is adequate for measuring the transverse dilatation of any unidirectional composite, and may be suitable for longitudinal measurements on some unidirectional composites also, such as the S2 glass/epoxy of the present work. The above statement assumes that the matrix material exhibits moisture dilatation while the fibers do not.

A Mettler Model HL 32 analytical balance was used for the constant monitoring of the specimen weights. It has the advantage that it can be tared externally by a voltage input, and has an "unstable output" signal allowing the computer to select stable periods to read the balance. The output is in Binary Coded Decimal (BCD) form. This has the advantage that the information can be read directly into the microprocessor without having to be converted to digital data. This reduces errors in weight data acquisition. In addition to recording time, displacement, and weight, a temperature and humidity transmitter was used to monitor

temperature and humidity during some of the testing.

The data acquisition system for the moisture experiments is unique, and totally developed by the Composite Materials Research Group at the University of Wyoming. It is based on a Zilog Z-80 microprocessor which, after starting a test, requires no additional operator assistance. Specimen names are input to a mini-floppy disk. Weight, dilatation, and time are recorded. The system provides several advantages over other moisture dilatation systems. For example, it constantly monitors times, displacements, and weights. It records power failures and is capable of retaring the balance after a power failure. This is particularly useful since minimal specific history of a test needs to be known.

The thermal dilatation data acquisition was much less automated than the moisture system. Prior to the present work, the thermal dilatometer was not capable of temperature excursions below room temperature. Therefore, a new test station had to be designed to obtain data over a wide temperature range. The criteria for design were as follows:

- 1) The temperature chamber must be capable of large temperature ranges; -73°C to 177°C (-100°F to 350°F),
- 2) The fixture must interface to existing equipment,
- 3) The fixture must be of a sufficiently large thermal mass so as to obtain uniform and steady temperature changes.

In the final design, developed as part of the present study, liquid nitrogen (LN_2) is pumped into the chamber to provide cooling, and a heater element is integral with the system. All of the above criteria were met, with the additional feature that the chamber is actually capable of going above 316°C (600°F). This allows the fixture to be

used for testing materials capable of withstanding much higher temperatures. Power input is made through an AC rheostat controller. Currently, a microprocessor-controlled temperature programmer is under development for use with the above test facility.

All final data reduction was accomplished using an HP 21MX-E mini-computer and a Versatec Model D1200A Matrix plotter. This system allows the operator to present the data in virtually any manner desired. The data reduction codes are included in Reference [22].

The following data indicate typical results of the experimental effort of the present study. Figures 12, 13 and 14 represent strain vs. moisture plots for the specimens. The remaining plots may be found in Reference [22]. A few comments will be noted here, as discussed in detail in Reference [22]. The starred data points are points recorded by a strip chart recorder and the smooth solid lines are best-fit curves generated and plotted by the data reduction computer routines. It was necessary during initial tests to take data by hand since the microprocessor data acquisition system was not yet fully operational. Only the data of Figure 12 shown here were totally obtained using the microprocessor system, although the system is now fully operational. The S2 glass/3501-6 composite tests show the most data scatter from one specimen to another. Also, the highly nonlinear moisture expansion curves for the S2 glass/3501-6 specimens will be noted. The 3501-6 epoxy resin curves appear to be the most linear. The AS/3501-6 and S2 glass/3501-6 composite specimen data were fit to cubic equations. The epoxy resin showed only slight nonlinearity so a linear moisture expansion behavior was assumed.

From experiment to experiment, the thermal dilatation experiments

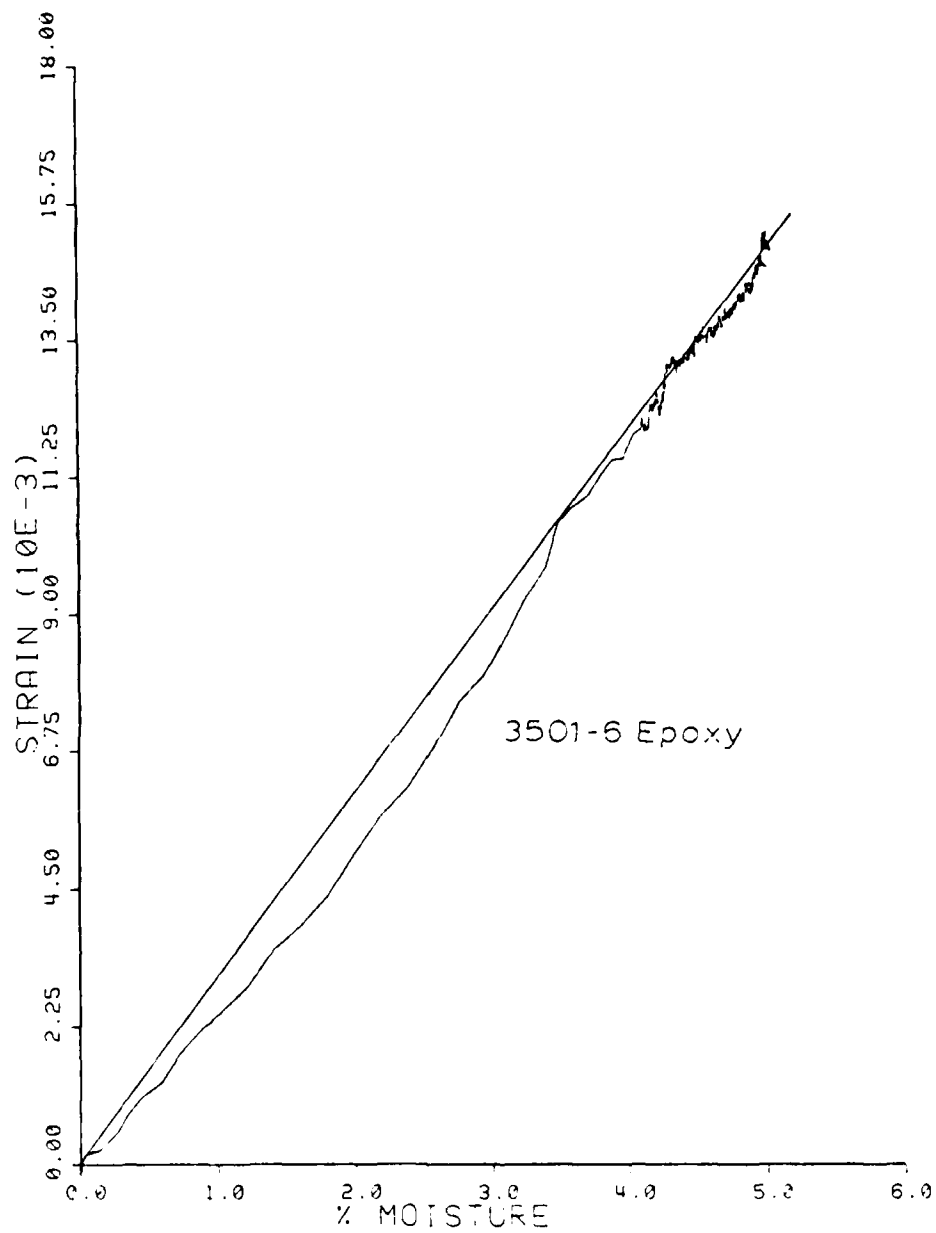

Figure 12. Results of Test 5, Station 2, 30 days @ 98% RH, 65.5°C (150°F).

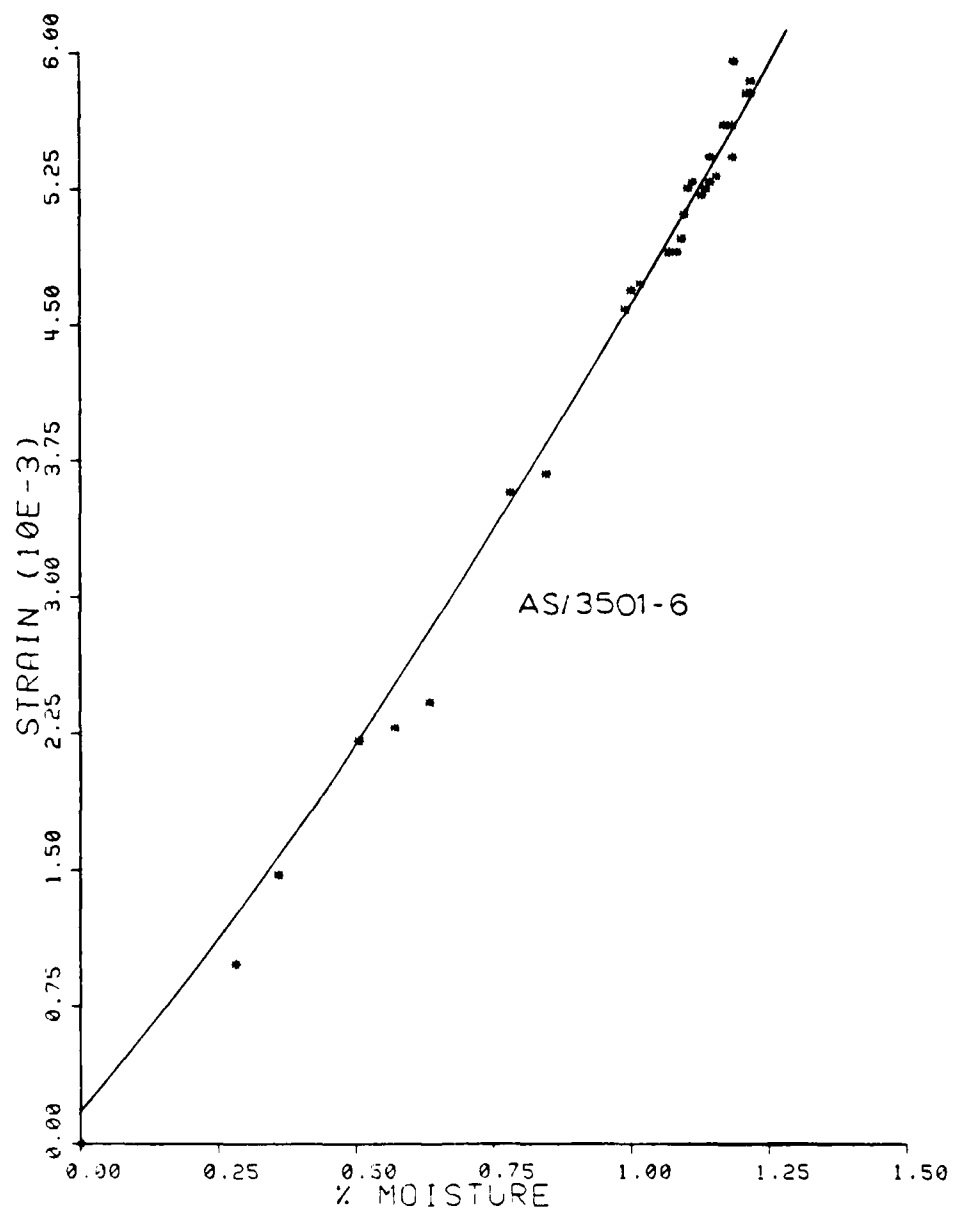

Figure 13. Results of Test 4, Station 3, 30 days @ 98% RH, 65.5°C (150°F).

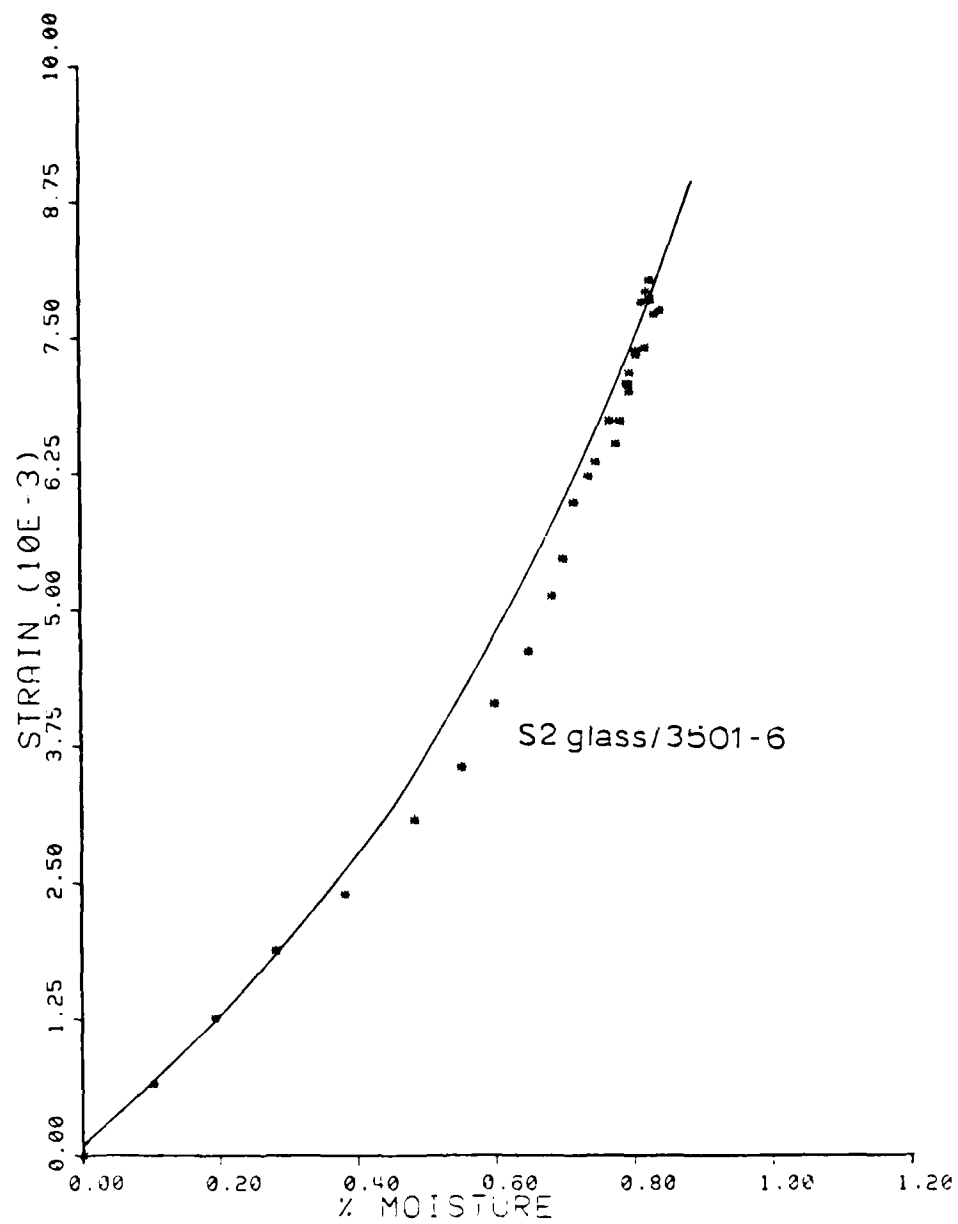

Figure 14. Results of Test 6, Station 3, 30 Days @ 98% RH, 65.5°C (150°F).

showed far less scatter than the moisture dilatation experiments. Representative examples are shown in Figures 15-17; the remainder of the data may be found in Reference [22]. The circles, triangles and squares represent individual data points, while the solid lines represent numerically-generated best-fit curves. Each type of symbol represents an individual test.

It will be noted that the 3501-6 resin shows the highest thermal expansion, followed by the AS/3501-6 and S2 glass/3501-6, respectively. This is as expected since the transverse modulus of a graphite fiber is lower, and transverse thermal expansion is higher, than for an S2 glass fiber. The fiber volume of the S2 glass/3501-6 composite specimens was also higher than that of the AS/3501-6 composite, further reducing the thermal expansion of these composites.

It should be noted that the thermal expansion is not linear over the present test temperature range. Also, since moisture serves as a plasticizer to the matrix material, higher nonlinearity is seen in moisture-conditioned composite specimens than dry composite specimens, due to a loss of modulus in the matrix. This loss of modulus affects the composite behavior on the micro level, which affects the resulting thermal expansion.

The microprocessor-controlled test station may also be used to calculate the moisture diffusivities of the various materials. The specimen geometry, i.e., 73 mm x 73 mm x 1.27 mm (2.88 in x 2.88 in x 0.050 in), was chosen so that essentially one-dimensional behavior is valid for calculating diffusivities. Less than 2 percent of the total surface area is represented by the edges. By contrast, a specimen that is 50.8 mm x 12.7 mm x 1.27 mm (2.0 in x 0.5 in x 0.050 in) has over

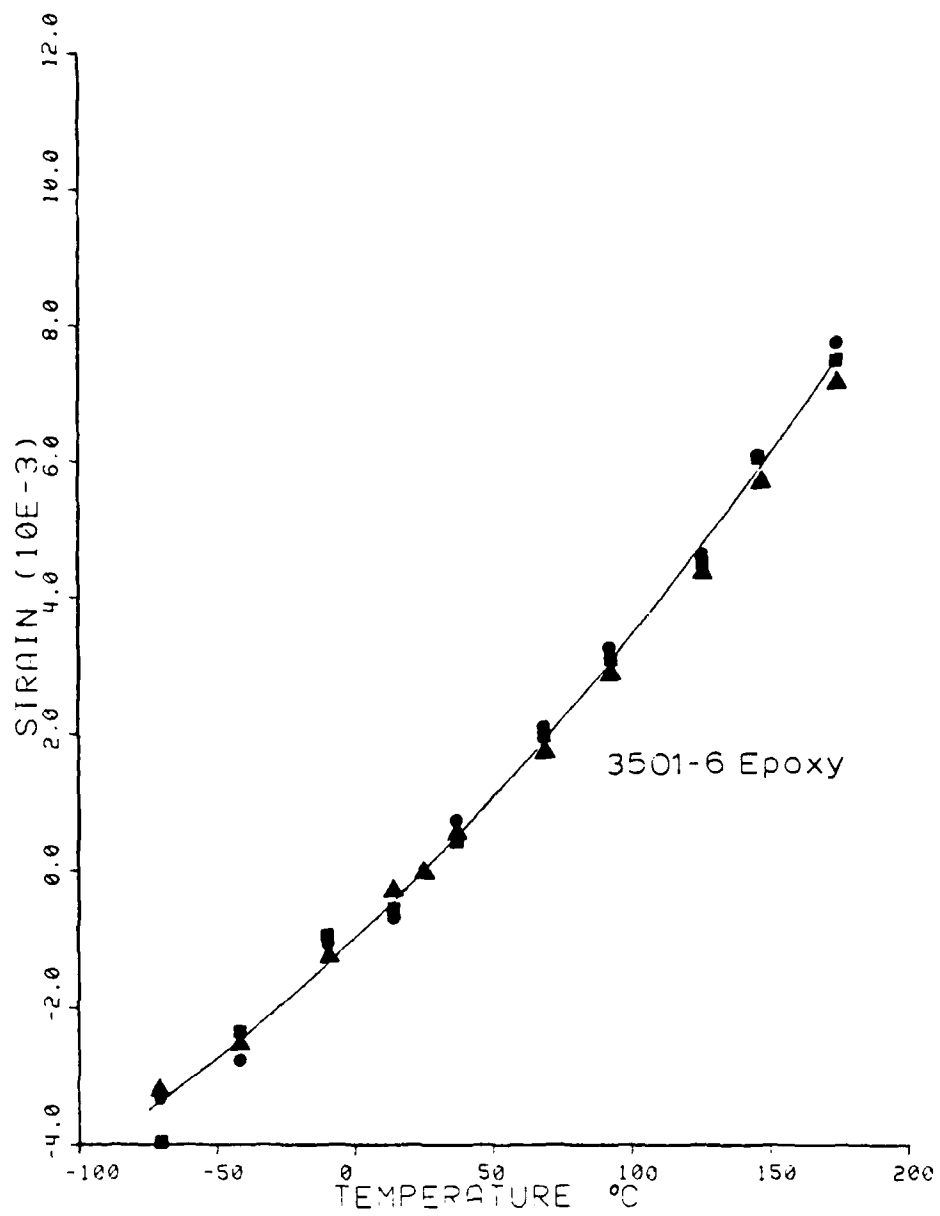

Figure 15. Thermal Expansion Data for Unconditioned Hercules 3501-6 Epoxy Resin.

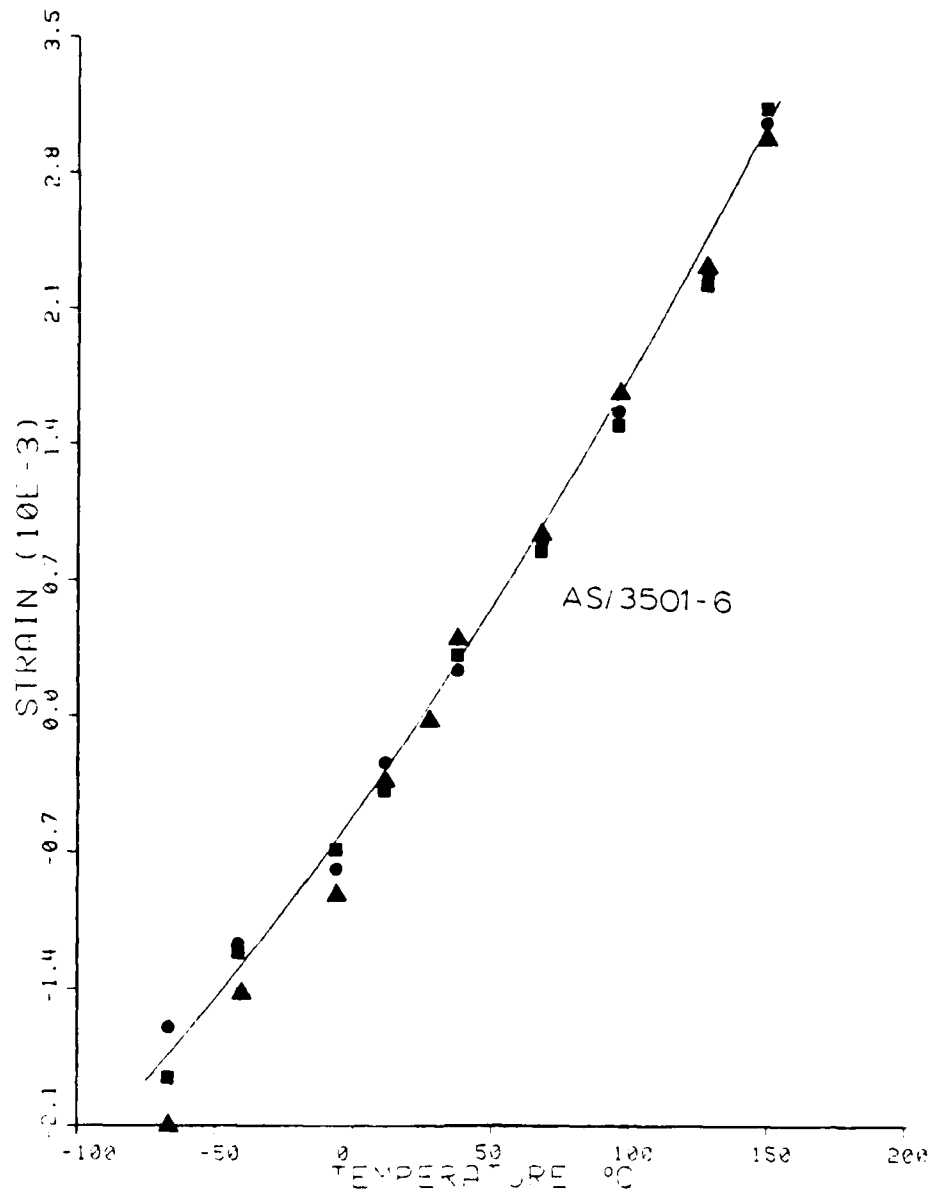

Figure 16. Transverse Thermal Expansion Data for Unconditioned Hercules AS/3501-6 Graphite/Epoxy Unidirectional Composite.

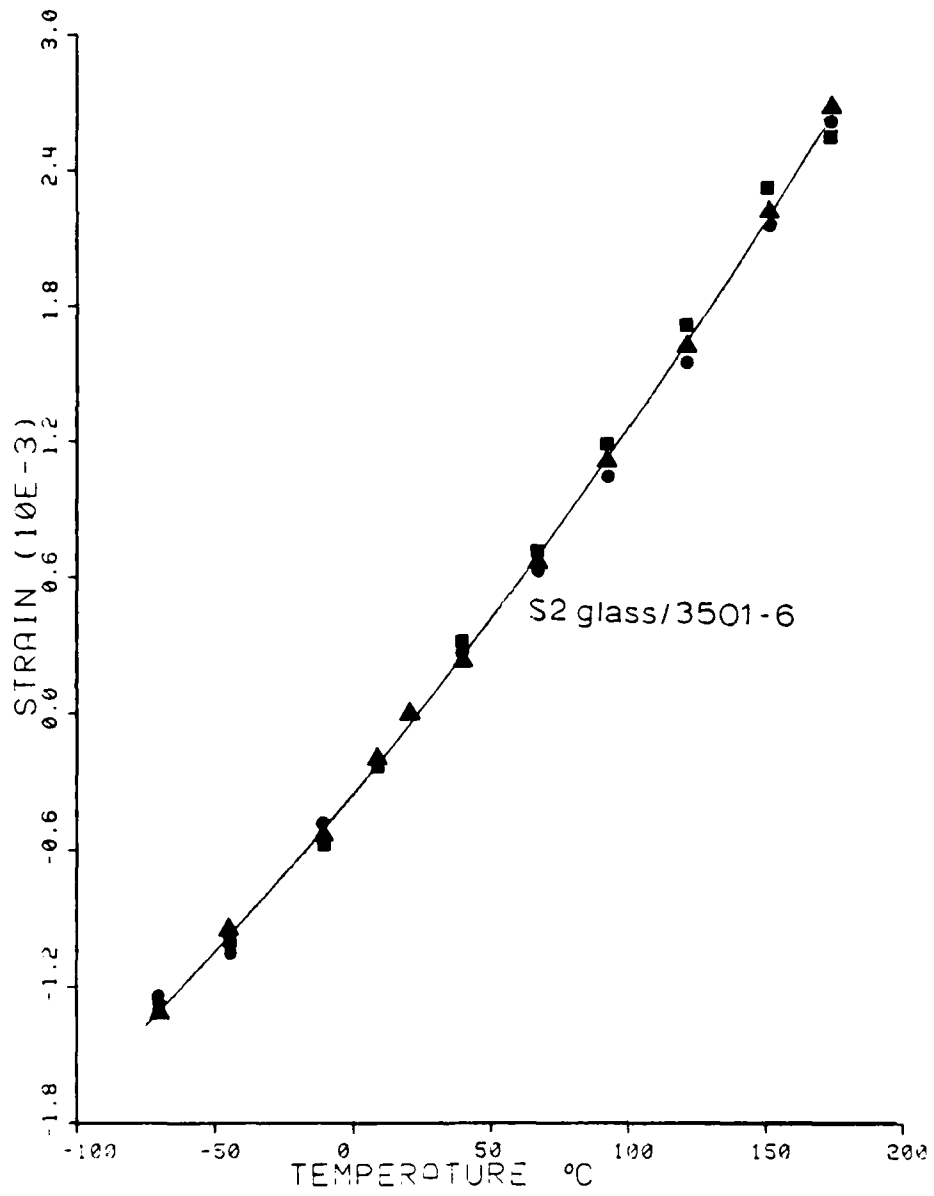

Figure 17. Transverse Thermal Expansion Data for Unconditioned S2 Glass/3501-6 Glass/Epoxy Unidirectional Composite.

11 percent of its total surface area taken up by edges, so the one-dimensional edge correction equation is less valid.

Moisture diffusion coefficients measured as part of the present study are presented and discussed in detail in Reference [22].

Using the measured thermal and moisture expansion coefficients of the neat epoxy matrix material as input, the micromechanics analysis was used to predict the unidirectional composite thermal and moisture expansion properties. These predictions were then correlated with the measured data. A complete presentation and discussion of results is given in Reference [22].

In summary, by using carefully controlled testing methods, reliable thermal and moisture expansion data have been determined. The technique developed here represents state-of-the-art data acquisition, with a flexibility to accommodate new and more accurate equipment as it becomes available. The data should serve as a base from which designers may account for thermal- and moisture-induced stresses and strains in composites.

SECTION 6

ABSTRACTS OF PUBLICATIONS OF RESULTS

6.1 Reports

B.G. Schaffer and D.F. Adams, "Nonlinear Viscoelastic Behavior of a Composite Material Using a Finite Element Micromechanical Analysis," Report UWME-DR-001-101-1, University of Wyoming, Department of Mechanical Engineering, June 1980 (141 pages).

The analysis uses an elastoplastic finite element micromechanics computer program to model a unidirectional composite subjected to any combination of longitudinal, transverse, and hygrothermal loadings. Time-dependent effects are included by means of nonlinear viscoelastic constitutive equations. The method of solution is based upon the conditions for generalized plane strain which permits a pseudo-three-dimensional analysis. It also contains two failure criteria, viz., an octahedral shear stress criterion and a hydrostatic criterion. Application of load or changes in temperature or moisture are input through time-independent increments. A plotting package is also included which allows the user to obtain a total of eight different plots; octahedral shear stress and strain, maximum and minimum principal stresses, in-plane shear stress, out-of-plane longitudinal stress, and normal and tangential shear stress on the fiber-matrix interface. The study demonstrates that the associated program is able to model essentially any type of stress input or hygrothermal history.

M.M. Monib and D.F. Adams, "Three-Dimensional Elastoplastic Finite Element Analysis of Laminated Composites," Report UWME-DR-001-102-1, University of Wyoming, Department of Mechanical Engineering, November 1980 (111 pages).

A three-dimensional elastoplastic analysis of generally orthotropic composite laminates is developed, together with a finite element

computer code for its implementation. The analysis is capable of handling any laminated composite subjected to triaxial mechanical and/or hygrothermal loading conditions. The laminates can consist of any number of orthotropic material plies, of any orientations. Elastoplastic material behavior is included by means of the tangent modulus method. The onset of plastic deformation is determined by a failure surface in three-dimensional space, and is likewise dependent on temperature and moisture.

The three-dimensional finite element analysis is based on a displacement formulation employing linear isoparametric elements. Large aspect ratios, typical of laminae finite element representations, are handled by the use of reduced integration techniques. Material properties are input to the analysis as coefficients of second order polynomials describing the elastoplastic response, and the dependence on temperature and moisture content. Incremental mechanical loadings can be applied as nodal forces and/or prescribed displacements. Hygrothermal loadings are applied as constant overall changes, or as spatial distributions, of temperature and moisture content. The computer program has been developed in modular form, which will permit it to be easily modified to accommodate future extensions of the analysis.

D.S. Cairns and D.F. Adams, "Moisture and Thermal Expansion of Composite Materials," Report UWME-DR-101-104-1, University of Wyoming, Department of Mechanical Engineering, November 1981 (204 pages).

An experimental technique is presented for determining the moisture and thermal expansion coefficients of polymers, and polymer-matrix composite materials. Materials tested included Hercules 3501-6 neat epoxy resin, Hercules AS/3501-6 graphite/epoxy composite and Owens-Corning S2 glass fibers in the same Hercules 3501-6 epoxy matrix.

Correlations of the experimentally determined moisture and thermal expansion properties with a nonlinear finite element micromechanics analysis are presented. Thermal expansion results for all three materials, both dry and moisture-conditioned, were obtained. Diffusivity constants were also experimentally determined. It is demonstrated that the moisture and thermal expansion of composite materials can be determined experimentally, and predicted numerically, with generally good results.

6.2 Journal Publications

M.N. Irion and D.F. Adams, "Compression Creep Testing of Unidirectional Composite Materials," Composites, Vol. 12, No. 2, April 1981, pp. 117-123.

Two new compression creep fixtures are described and evaluated. One loads a specimen along the sides, whereas the other provides side support to a specimen and allows end loading. Both fixtures were used to test unidirectional composites, in static compression and in compression creep. The two unidirectional materials used were glass/epoxy and graphite/epoxy, tested longitudinally and transversely.

B.G. Schaffer and D.F. Adams, "Nonlinear Viscoelastic Analysis of a Unidirectional Composite Material," Journal of Applied Mechanics, Vol. 48, No. 4, December 1981, pp. 859-865.

The single-integral nonlinear viscoelastic constitutive equations developed by Schapery from thermodynamic theory have been adapted to analyze the time-dependent response of a unidirectional composite material. This viscoelastic analysis has been combined with an existing time-independent elastoplastic micromechanics analysis, to permit the study of nonlinear time-dependent response of materials loaded beyond their elastic limit. Literature values as well as a brief series of

creep-recovery tests on a typical epoxy resin were used to characterize the nonlinear viscoelastic response of the matrix constituent of a composite material. Composite response under transverse loading at various stress levels was then predicted, and the results compared with actual composite creep data.

6.3 Published Conference Proceedings

D.F. Adams, "Micromechanical Failure Predictions for Polymer-Matrix Composites," Proceedings of the Fifth International Conference on Deformation, Yield and Fracture of Polymers, Cambridge University, Cambridge, England, March 1982.

A micromechanics analysis and associate finite element computer program have been developed, and used here to predict the inelastic stress state and crack propagation in a model composite. The model includes a single broken fiber surrounded by a sheath of matrix, this composite being subjected to an axial tensile stress. Both glass/epoxy and graphite/epoxy composites, for various fiber volume ratios, are modeled. Curing residual stresses, and hygrothermal effects induced at elevated temperatures in humid environments, are included. Results demonstrate the ability to propagate a stable crack, and will be useful in correlating with experiments to study the role of the matrix in the failure process.

D.F. Adams, "Influence of the Polymer Matrix on the Mechanical Response of a Unidirectional Composite," Proceedings of the Fourth International Conference on Composite Materials, Tokyo, Japan, October 1982.

A finite element micromechanics analysis is used to predict the influence of the matrix on the unidirectional lamina properties of a composite laminate. Experimentally determined epoxy matrix properties are used as a basis for comparison for the many new polymer matrix

systems currently being developed. The influence of increased strain to failure of the matrix on bulk properties such as coefficients of thermal and moisture expansion are presented. In addition, local stress distributions in the matrix around individual fibers are shown.

D.F. Adams and B.G. Schaffer, "Analytical/Experimental Correlations of Stiffness Properties of Unidirectional Composites," Composites Technology Review, Vol. 4, No. 2, Summer 1982, pp. 45-48.

A finite element micromechanics analysis is used to predict the longitudinal and transverse moduli of both graphite/epoxy and glass/epoxy unidirectional composites, as a function of temperature, for various moisture preconditionings. These predictions are then correlated with corresponding experimental data. The micromechanics analysis includes temperature- and moisture-dependent matrix material properties, inelastic matrix stress-strain response, and anisotropic fibers. Thermal residual stresses due to cooldown from the cure temperature, and moisture-induced swelling stresses, are included in the analysis. Good correlation is obtained between theory and experiment.

J.M. Mahishi and D.F. Adams, "Fracture Behavior of a Single-Fiber Graphite/Epoxy Model Composite Containing a Broken Fiber or Cracked Matrix," Journal of Materials Science, accepted for publication.

A micromechanical analysis of crack initiation and propagation from a broken fiber end, or in the region of a matrix crack, in a graphite/epoxy composite model is considered. The model consists of a single fiber embedded in an annular sheath of matrix material subjected to axial tension. An elastoplastic, axisymmetric finite element analysis has been used. Curing residual stresses, and hygrothermal effects induced due to changes in service temperature and humidity, are included. The influence of the interface between the fiber and matrix

material on the behavior of propagating cracks is also studied. The concept of crack growth resistance curves (K_R -curves) has been used to determine the point of crack instability. Results demonstrate the usefulness of the analytical model in understanding the role of the matrix material in the failure process of composites.

6.4 Seminars and Presentations

Speaker - "Contribution of the Polymer Matrix to the Hygrothermal and Mechanical Response of a Composite Material," Golden Jubilee Meeting, The Society of Rheology, Boston, Massachusetts, October 1979.

Seminar - "Analysis and Testing of High Performance Composite Materials," National Aeronautical Laboratory, Bangalore, India, January 1980.

Seminar - "Hygrothermal Effects in Polymer-Matrix Composite Materials," Vikram Sarabhai Space Centre, Trivandrum, India, January 1980.

Seminar - "Static and Fatigue Properties of Graphite/Epoxy Composites," Texas A & M University, College Station, Texas, February 1980.

Seminar - "Composite Materials Testing and Characterization," DFVLR-Braunschweig, Braunschweig, West Germany, July 1980.

Seminar - "Composite Materials Testing and Characterization," SIGRI Electrographit GmbH, Meitingen, West Germany, July 1980.

Seminar - "Temperature- and Moisture-Induced Stresses in Composite Materials," Messerschmidt-Bolknow-Blohm, GmbH (MBB), Munich, West Germany July 1980.

Seminar - "Static Compression and Compression Fatigue Properties of Graphite/Epoxy Composites," DFVLR-German Aerospace Research Establishment, Stuttgart, West Germany, July 1980.

Session Chairman - Fatigue and Fracture, Third International Conference on Composite Materials, Paris, France, August 1980.

Speaker - "Micromechanical Creep, Longitudinal Shear, and 3-D Laminate Analyses," Third Annual Army Composite Materials Research Review, Williamstown, Massachusetts, October 1980.

Seminar - "Recent Advances in Composite Materials, Los Alamos Scientific Laboratory, Los Alamos, New Mexico, November 1980.

Seminar - "Hygrothermal Stability of Laminated Composites," Bendix Corporation, Southfield, Michigan, February 1981.

Seminar - "Composite Materials Research at the University of Wyoming," Colorado State University, Fort Collins, Colorado, April 1981.

Seminar - "Analysis Methods for Composite Materials," International Harvester Co. Chicago, Illinois, June 1981.

Seminar - "Analysis Methods for Composite Bearing Materials," Smith Tool Co., Irvine, California, June 1981.

Seminar - "Fracture of Composites," Sandia Laboratories, Albuquerque, New Mexico, June 1981.

Seminar - "Design with Carbon Fiber Composites," Ministry of the Chemical Industry, Peking, China, July 1981.

Seminar - "Test Methods for Composite Materials," Centro Tecnico Aeroespacial, Sao Jose dos Compos, Brazil, October 1981.

Speaker - "Unidirectional Ply Properties," Conference on Advanced Composites: New Directions in Performance and Reliability, Society of Plastics Engineers, Louisville, Kentucky, November 1981.

Session Chairman - Fracture, Fifth International Conference on Deformation, Yield and Fracture of Polymers, Cambridge University, Cambridge, England, March 1982.

Seminar - "Test Methods for Composite Materials," Ciba-Geigy Corporation, Duxford, England, April 1982.

Seminar - "Iosipescu Shear Testing of Materials," Imperial Chemical Industries, Welwyn Garden City, England, April 1982.

Seminar - "Micromechanical Analyses of Composite Materials," University of Liverpool, Liverpool, England, April 1982.

Seminar - "Compression and Creep Testing of Graphite/Epoxy Composites," Queen Mary College, University of London, London, England, April 1982.

Seminar - "Thermal Response Characteristics of Composite Laminates," Cranfield Institute of Technology, Cranfield, Bedford, England, April 1982.

SECTION 7

PARTICIPATING SCIENTIFIC PERSONNEL

The Composite Materials Research Group makes extensive use of undergraduate students in its research programs, these students working closely with both the full-time professional staff, and graduate students. The organization of the Composites Group in the Spring of 1982 is shown in Figure 12. A number of graduate students were involved during the course of the present grant study; those working specifically on the ARO grant were as follows:

Mohamed M. Monib	Ph.D.	1980
Brent G. Schaffer	M.S.	1980
Mark N. Irion	M.S.	1980
Steven V. Hayes	M.S.	1980
David A. Crane	M.S.	1981
Douglas S. Cairns	M.S.	1981
Jayant M. Mahishi	Ph.D.	1983
Raja Mohan	M.S.	1983

COMPOSITE MATERIALS RESEARCH GROUP
 MECHANICAL ENGINEERING DEPARTMENT
 UNIVERSITY OF WYOMING
 SPRING 1982

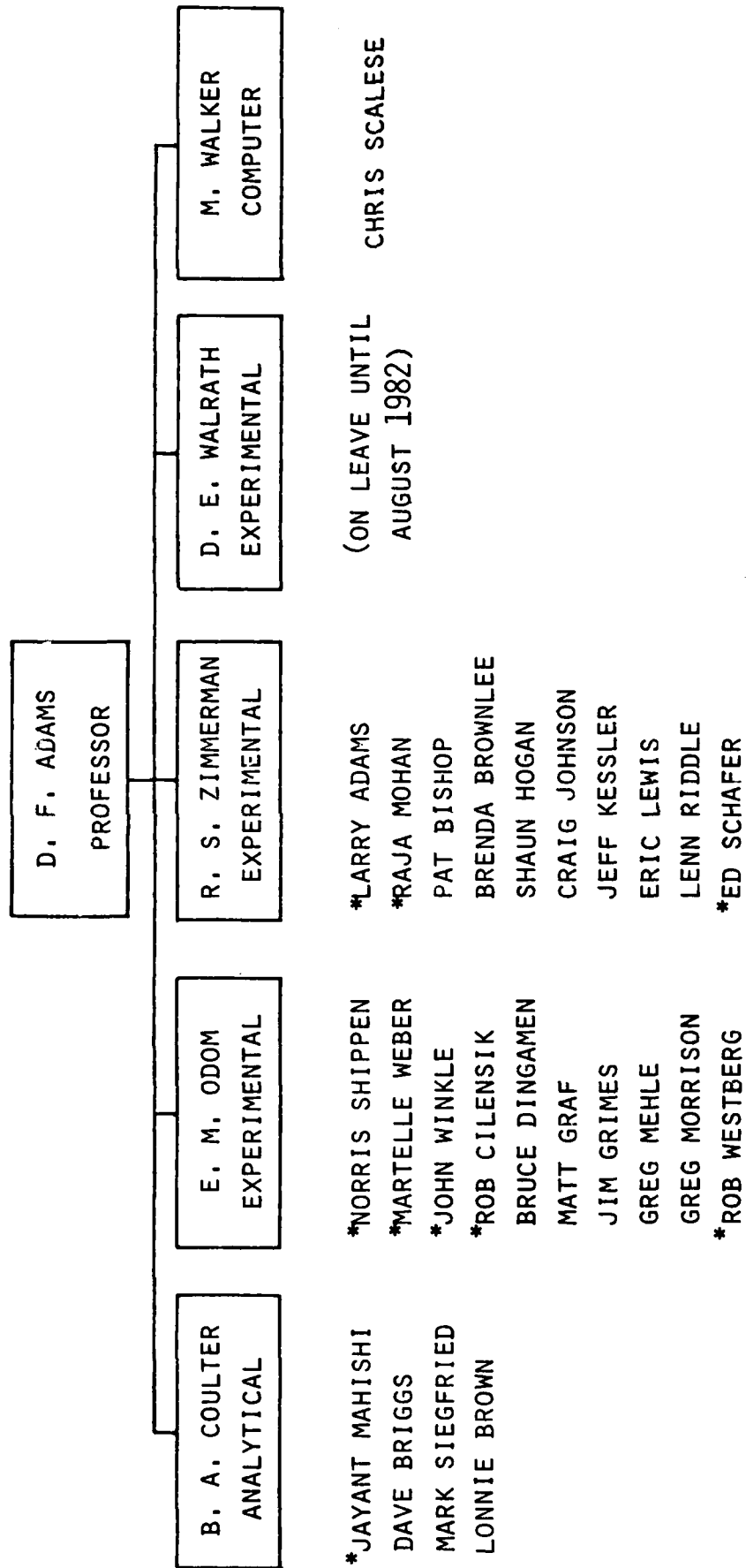

* CURRENT GRADUATE STUDENTS

Figure 12. Composite Materials Research Group Organization.

REFERENCES

1. D.F. Adams and D.E. Walrath, "Hygrothermal Response of Polymer-Matrix Composite Materials," U.S. Army Research Office Grant Nos. DAAG 29-76-G-0163 and DAAG 29-78-G-0053, February 1967 - February 1979.
2. A.K. Miller and D.F. Adams, "Micromechanical Aspects of the Environmental Behavior of Composite Materials," Report UWME-DR-701-1111, University of Wyoming, Department of Mechanical Engineering, January 1977.
3. D.F. Adams and D.E. Walrath, "Hygrothermal Response of Polymer Matrix Composite Materials," Report UWME-DR-901-102-1, University of Wyoming, Department of Mechanical Engineering, September 1979.
4. D.F. Adams and A.K. Miller, "Hygrothermal Microstresses in a Unidirectional Composite Exhibiting Inelastic Material Behavior," Journal of Composite Materials, Vol. 11, No. 3, July 1977, pp. 285-299.
5. A.K. Miller and D.F. Adams, "Inelastic Finite Element Analysis of a Heterogeneous Medium Exhibiting Temperature and Moisture Dependent Material Properties," Fibre Science and Technology, Vol. 13, No. 2, March-April 1980, pp. 135-153.
6. B.G. Schaffer and D.F. Adams, "Nonlinear Viscoelastic Behavior of a Composite Material Using a Finite Element Micromechanical Analysis," Report UWME-DR-001-101-1, University of Wyoming, Department of Mechanical Engineering, June 1980.
7. B.G. Schaffer and D.F. Adams, "Nonlinear Viscoelastic Analysis of a Unidirectional Composite Material," Journal of Applied Mechanics, Vol. 48, No. 4, December 1981, pp. 859-865.
8. M.N. Irion and D.F. Adams, "Compression Creep Testing of Unidirectional Composite Materials," Composites, Vol. 12, No. 2, April 1981, pp. 117-123.
9. D.A. Crane and D.F. Adams, "Finite Element Micromechanical Analysis of a Unidirectional Composite Including Longitudinal Shear Loading," Report UWME-DR-101-101-1, University of Wyoming, Department of Mechanical Engineering, February 1981.
10. D.P. Murphy and D.F. Adams, "Energy Absorption Mechanisms During Crack Propagation in Metal Matrix Composites," Report UWME-DR-901-103-1, University of Wyoming, Department of Mechanical Engineering, October 1979.
11. D.F. Adams and D.P. Murphy, "Analysis of Crack Propagation as an Energy Absorption Mechanism in Metal Matrix Composites," Report UWME-DR-101-102-1, University of Wyoming, Department of Mechanical Engineering, February 1981.

12. D.F. Adams, and J.M. Mahishi, "Micromechanical Predictions of Crack Propagation and Fracture Energy in a Single-Fiber Boron/Aluminum Model Composite," Report UWME-DR-201-101-1, University of Wyoming, Department of Mechanical Engineering, February 1982.
13. J.M. Mahishi and D.F. Adams, "Micromechanical Predictions of Crack Initiation, Propagation and Crack Growth Resistance in Boron/Aluminum Model Composites," Journal of Composite Materials, Vol. 16, 1982.
14. J.M. Mahishi and D.F. Adams, "Fracture Behavior of a Single-Fiber Graphite/Epoxy Model Composite Containing a Broken Fiber or Cracked Matrix," Journal of Materials Science, Vol. 17, 1982.
15. D.F. Adams, and A.K. Miller, "The Influence of Material Variability on the Predicted Environmental Behavior of Composite Materials," Journal of Engineering Materials and Technology, Vol. 100, No. 1, January 1978, pp. 77-83.
16. D.F. Adams, "Analysis of the Compression Fatigue Properties of a Graphite/Epoxy Composite," Proceedings of the Third International Conference on Composite Materials, Paris, France, August 1980.
17. D.F. Adams, "Influence of Moisture on Compression Fatigue of Graphite/Epoxy Composites," Proceedings of the International TTCP Critical Review: Techniques for the Characterization of Composite Materials, Massachusetts, Institute of Technology, Cambridge, Massachusetts, June 1981.
18. "Micromechanical Failure Predictions for Polymer-Matrix Composites, Proceedings of the Fifth International Conference on Deformation, Yield and Fracture of Polymers, Cambridge University, Cambridge, England, March 1982.
19. D.F. Adams, "Influence of the Polymer Matrix on the Mechanical Response of a Unidirectional Composite," Proceedings of the Fourth International Conference on Composite Materials, Tokyo, Japan, October 1982.
20. G.C. Grimes and D.F. Adams, "Investigation of Compression Fatigue Properties of Advanced Composites," Northrop Technical Report NOR 79-17, Naval Air Systems Command Contract N00019-77-C-0519, October 1979.
21. G.C. Grimes, D.F. Adams, and E.G. Dusablon, "The Effects of Discontinuities on Compression Fatigue Properties of Advanced Composites," Northrop Technical Report NOR 80-158, Naval Air Systems Command Contract N00019-79-C-0276, October 1980.
22. D.S. Cairns and D.F. Adams, "Moisture and Thermal Expansion of Composite Materials," Report UWME-DR-101-104-1, University of Wyoming, Department of Mechanical Engineering, November 1981.

23. D.F. Adams and B.G. Schaffer, "Analytical/Experimental Correlations of Stiffness Properties of Unidirectional Composites," Composites Technology Review, Vol. 4, No. 2, Summer 1982, pp. 45-48.
24. D.E. Walrath and D.F. Adams, "Moisture Absorption Analysis of the Thematic Mapper Graphite/Epoxy Composite Structure," in bound volume entitled Modern Developments in Composite Materials and Structures, ASME Winter Annual Meeting, New York, New York, December 1979.
25. E.M. Odom and D.F. Adams, "Design and Fabrication of a Motorcycle Swingarm Utilizing Composite Materials," Report UWME-DR-201-102-0, University of Wyoming, Department of Mechanical Engineering, May 1982.
26. E.M. Odom and D.F. Adams, "Design and Fabrication of a Motorcycle Swingarm Utilizing Composite Materials," Proceedings of the 1982 SAE West Coast International Meeting, San Francisco, California, August 1982.
27. M.M. Monib and D.F. Adams, "Three-Dimensional Elastoplastic Finite Element Analysis of Laminated Composites," Report UWME-DR-001-102-1, University of Wyoming, Department of Mechanical Engineering, November 1980.
28. S.J. Davis and D.F. Adams, "Thermal Deformation of Various Composite Material Ski Constructions," Report UWME-DR-101-103-1, University of Wyoming, Department of Mechanical Engineering, May 1981.
29. S.J. Davis and D.F. Adams, "Thermal Deformation of Various Composite Material Ski Constructions," SAMPE Journal, Vol. 18, No. 3, May/June 1982, pp. 8-16.
30. R.L. Ramkumar, G.C. Grimes, D.F. Adams, and E.G. Dusablon, "Effects of Materials and Processed Defects on the Compression Properties of Advanced Composites," Northrop Technical Report NOR 82-103, Naval Air Systems Command Contract N00019-80-C-0484, May 1982.
31. D.E. Walrath and D.F. Adams, "Fatigue Behavior of Hercules 3501-6 Epoxy Resin," Report No. NADC-78139-60, Naval Air Development Center Contract No. N62269-78-C-0340, January 1980.
32. "A Study of Polymer Matrix Fatigue Properties," Contract N62269-80-C-0278, Naval Air Development Center, Warminster, Pennsylvania, September 1980 - February 1983.
33. E.M. Odom and D.F. Adams, "Stiffness Reductions During Tensile Fatigue Testing of Graphite/Epoxy Angle-Ply Laminates," NASA Contractor Report 166019 (University of Wyoming Report UWME-DR-201-105-1), NASA-Langley Research Center, Hampton, Virginia, November 1982.

34. M.N. Irion, "Compression Creep Testing of Composite Materials," M.S. Thesis, Department of Mechanical Engineering, University of Wyoming, Laramie, Wyoming, May 1980.
35. R.M. Gallagher, J. Padlog, and P.P. Bijloard, "Stress Analysis of Heated Complex Shapes," J. Aero-Space Sci., 1962, pp. 700-707.
36. R.J. Melosh, "Structural Analysis of Solids," Proc. ASCE, ST-4, August 1963, pp. 205-223.
37. O.C. Zienkiewicz, The Finite Element Method, McGraw-Hill Book Co., London, England, 1967.
38. O.C. Zienkiewicz, R.T. Taylor, and J.M. Too, "Reduced Integration Technique in General Analysis of Plates and Shells," Int. J. Num. Meth. Engng., Vol. 3, April 1971, pp. 275-290.
39. B.M. Irons, "A Frontal Solution Technique for Finite Element Analysis," Int. J. Num. Meth. Engng., Vol. 2, January 1970, pp. 5-32.
40. A. Alizadeh and G.T. Will, "A Substructured Frontal Solver and its Application to Localized Material Nonlinearity," Computers & Structures, Vol. 10, September 1979, pp. 225-231.
41. D.K.Y. Kan, "A Simple Front Solution Technique for Finite Element Method," Report CNME-CR-51, Dept. of Civil Engineering, University College of Swansea, Swansea, U.K., 1971.
42. R.B. Pipes and N.J. Pagano, "Interlaminar Stresses in Composite Laminates Under Uniform Axial Extension," Journal of Composite Materials, Vol. 4, October 1970, pp. 538-548.
43. E.F. Rybicki and D.W. Schmueser, "Effect of Stacking Sequence and Lay-up Angle on Free Edge Stresses Around a Hole in a Laminated Plate Under Tension," Journal of Composite Materials, Vol. 12, July 1978, pp. 300-313.

4-83

DTIC