



US007954757B2

(12) **United States Patent**
Moe et al.

(10) **Patent No.:** **US 7,954,757 B2**

(45) **Date of Patent:** **Jun. 7, 2011**

(54) **LANDING GEAR NOISE ATTENUATION**

(56)

References Cited

(75) Inventors: **Jeffrey W. Moe**, Chula Vista, CA (US);
Julia Whitmire, Chula Vista, CA (US);
Hwa-Wan Kwan, Chula Vista, CA (US);
Amal Abeysinghe, Bonita, CA (US)

U.S. PATENT DOCUMENTS

202,634 A	4/1878	Connor
1,446,531 A	2/1923	Williams, Jr.
2,129,824 A	9/1938	De Seversky
2,176,461 A	10/1939	Larsen
2,180,462 A	11/1939	De Seversky
2,363,126 A	11/1944	Gibson

(Continued)

(73) Assignee: **Goodrich Corporation**, Charlotte, NC (US)

(*) Notice: Subject to any disclaimer, the term of this patent is extended or adjusted under 35 U.S.C. 154(b) by 955 days.

FOREIGN PATENT DOCUMENTS

CA 2223543 6/1998

(Continued)

(21) Appl. No.: **10/599,495**

(22) PCT Filed: **Mar. 25, 2005**

(86) PCT No.: **PCT/US2005/010082**

§ 371 (c)(1),
(2), (4) Date: **Aug. 20, 2007**

OTHER PUBLICATIONS

Ahuja K.K., Martin, J., Miller B., & Gu X., "On Automobile Antenne and Roof Rack Noise Control," AIAA 93-4398, 15th AIAA Aeroacoustics Conference, Long Beach, CA, Oct. 25-27, 1993.

(Continued)

(87) PCT Pub. No.: **WO2005/096721**

PCT Pub. Date: **Oct. 20, 2005**

Primary Examiner — J. Woodrow Eldred

(74) *Attorney, Agent, or Firm* — Womble Carlyle Sandridge & Rice, PLLC

(65) **Prior Publication Data**

US 2008/0142634 A1 Jun. 19, 2008

Related U.S. Application Data

(60) Provisional application No. 60/557,236, filed on Mar. 29, 2004, provisional application No. 60/641,246, filed on Jan. 4, 2005.

(51) **Int. Cl.**
B64C 25/00 (2006.01)

(52) **U.S. Cl.** **244/100 A**; 244/100 R; 244/102 R;
244/102 A

(58) **Field of Classification Search** 244/100 A,
244/100 R, 102 R

See application file for complete search history.

(57) **ABSTRACT**

A landing gear noise attenuator mitigates noise generated by airframe deployable landing gear. The noise attenuator can have a first position when the landing gear is in its deployed or down position, and a second position when the landing gear is in its up or stowed position. The noise attenuator may be an inflatable fairing that does not compromise limited space constraints associated with landing gear retraction and stowage. A truck fairing mounted under a truck beam can have a compliant edge to allow for non-destructive impingement of a deflected fire during certain conditions.

32 Claims, 33 Drawing Sheets

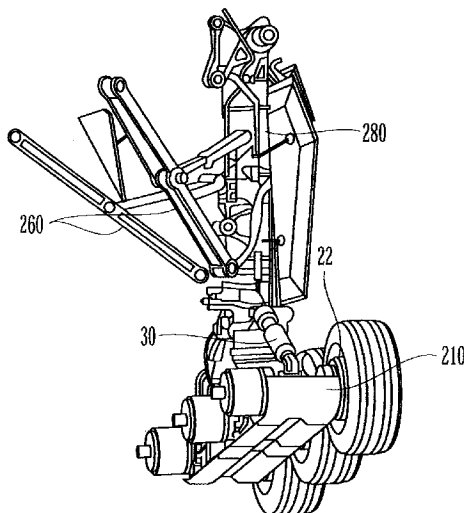

U.S. PATENT DOCUMENTS

2,406,710	A	8/1946	Riggles, Jr.
2,652,214	A	9/1953	Cussons
2,719,016	A	9/1955	Wicks
2,747,817	A	5/1956	Saulnier
4,027,836	A	6/1977	Seibel
5,058,827	A	10/1991	Dansereau et al.
5,104,063	A	4/1992	Harley
5,156,353	A	10/1992	Gliebe et al.
5,209,434	A	5/1993	Lo Presti et al.
5,269,481	A	12/1993	Derrien
5,478,030	A	12/1995	Derrien et al.
5,749,546	A	5/1998	Blackner et al.
6,032,090	A	2/2000	von Bose
6,048,477	A	4/2000	Thorpe et al.
6,173,920	B1	1/2001	Meneghetti
6,454,219	B1	9/2002	Moe
6,457,680	B1	10/2002	Dobrzynski et al.
6,619,587	B1	9/2003	Chow et al.
6,786,451	B2*	9/2004	Courtois et al. 244/102 R
2003/0102406	A1	6/2003	Chow et al.
2003/0152145	A1	8/2003	Kawakita
2003/0164423	A1	9/2003	Courois et al.
2003/0225492	A1	12/2003	Cope et al.
2004/0040797	A1	3/2004	Plude et al.
2004/0104301	A1	6/2004	Wickerhoff et al.

FOREIGN PATENT DOCUMENTS

DE	69715787	2/2003
EP	846540	6/1998
EP	1067045	10/2001
EP	1192077	8/2004
EP	1340676	6/2005
ES	2179282	6/1998
FR	2836667	7/2004
GB	494542	10/1938
GB	534522	3/1941
GB	745965	3/1956
GB	9915977	9/1999
GB	2319981	8/2001
JP	2003/504267	2/2003
WO	WO01/04003	1/2001

OTHER PUBLICATIONS

Carter, Guillot, Ng & Copenhaver, "Aerodynamic Performance of a High-Turning Compressor Stator with Flow Control," AIAA 37th Joint Propulsion Conf., 2001, Salt Lake City, Utah.

Davy, R. & Remy, H., "Airframe Noise Characteristics of a 1/11 Scale Airbus Model", 4th AIAA/CEAS Aeroacoustics Conf., Jun. 2-4, 1998, Toulouse, France.

Dobrzynski W. & Buchholz H., Full-Scale Noise Testing on Airbus Landing Gears in the German Dutch Wind Tunnel, 3rd AIAA/CEAS Aeroacoustics Conf, Paper 97-1597, May 12-14, 1997.

Dobrzynski W., Chow L.C., Guion P., & Shiells D., A European Study on Landing Gear Airframe Noise Sources, 5th AIAA/CEAS Aeroacoustics Conference & Exh., Jun. 12-14, 2000.

Fink M.R., Airframe Noise Prediction Methods, FAAA-RD-77-29, 1977.

Fink, Martin R. & Bailey, D.A., Model Test of Airframe Noise Reduction Concepts, AIAA 6th Aeroacoustics Conf, Jun. 4-6, 1980, Hartford, CT.

Hardin, Jay C., Toward a Comprehensive Analysis of Landing Approach Noise Sources, AIAA-97-1593-CP, 1997.

Hayes, Julie A.; Horne, W. Clifton; Soderman, Paul T. & Bent, Paul H., Airframe noise characteristics of a 4.7% scale DC-10 model, AIAA-97-1594-CP.

Heidelberg, L.J., Hall, D.G., Bridges, J.E., & Nallasamy, M., A Unique Ducted Fan Test Bed for Active Noise Control and Aeroacoustics Research, CEAS/AIAA-96-1740, May 1996.

Heller, Hanno H. & Dobrzynski, Werner M., Sound Radiation From Aircraft Wheel-Well/Landing-Gear Configurations, Journal of Aircraft, vol. 14, No. 8, 1977.

Heller, Hanno H. & Dobrzynski, W.M., Unsteady Pressure Characteristics on Aircraft Components and Far-field Radiated Airframe Noise, Journal of Aircraft, vol. 15, #12, Dec. 1978.

Jaeger, S.M., 777 Landing Gear Acoustics: Even More Preliminary Acoustic Results, NASA AST-QAT 4th Airframe Noise.

Konstadinopoulos, P., Mook, D.T., & Nayfeh, A.H. (1981), A Numerical Method for General Unsteady Aerodynamics, AIAA Atmospheric Flight Mechanics Conf, 1981.

Konstadinopoulos, P., Thrasher, D.F., D.T. Mook, Nayfeh, A.H., & Watson, L.(1985), A Vortex-Lattice Method for General, Unsteady Aerodynamics, Journal of Aircraft, 22(1),43-49.

Larsen J.V. & Devenport W.J., Acoustic Properties of the Virginia Tech Stability Wind Tunnel, Dept of Aerospace & Ocean Eng, VA Tech, Rpt VPI-AOE 263,1999.

Macaraeg M.G., Fundamental Investigation of Airframe Noise, NASA Langley Research Center Report, 1998.

Miller, Wendell R.; Meecham, William C. & Ahtye, Warren F., Large Scale Model Measurements of Airframe Noise Using Cross-Correlation Techniques, J.Acoust. Soc. Am. 71(3), Mar. 1982.

Munson A.G., A Modeling Approach to Nonpropulsive Noise, AIAA 76-525, 1976.

Piet, Jean-Francois & Elias Georges, Airframe Noise Source Localization Using a Microphone Array, AIAA-97-1643-CP.

Preidikman, S. Numerical Simulations of Interactions Among Aerodynamics, Structural Dynamics, and Control Systems, PhD thesis, VA Polytechnic Inst. & State Univ., 1998.

Rao, W.M., Feng, J., Burdisso, R.A., Wg, W.F., Experimental Demonstration of Active Flow Control to Reduce Unsteady Stator-Rotor Invention, AIAA J., vol. 39, #3, Mar. 2001, pp. 458-464.

Stoker, R.W. & Sen, R., An Experimental Investigation of Airframe Noise Using a Model-Scale Boeing 777, AIAA-2001-0987, 39th AIAA Aerospace Sciences Mtg & Exh., Jan. 8, 2001, Reno, NV.

Stoker, R.W., Recent Airframe Noise Testing Done by Boeing, Presented at the NASA AST-QAT 4th Airframe Noise Workshop, Dec. 2000.

Stoker, R.W., Underbrink, J.R. & Neubert, F.R., Investigations of Airframe Noise in Pressurized Wind Tunnel, AIAA-2001-2107, 7th AIAA/CEAS Aeroacoustics Conf, May 28, 2001, NL.

Willshire, W.L., Jr. & Garber, D.P., Advanced Subsonic Transport Approach Noise—The Relative Contribution of Airframe Noise, NASA Tech Memo 104112, Jun. 1992.

International Preliminary Search Report on Patentability, Int. Application No. PCT/US2005/010082 dated Oct. 4, 2006.

* cited by examiner

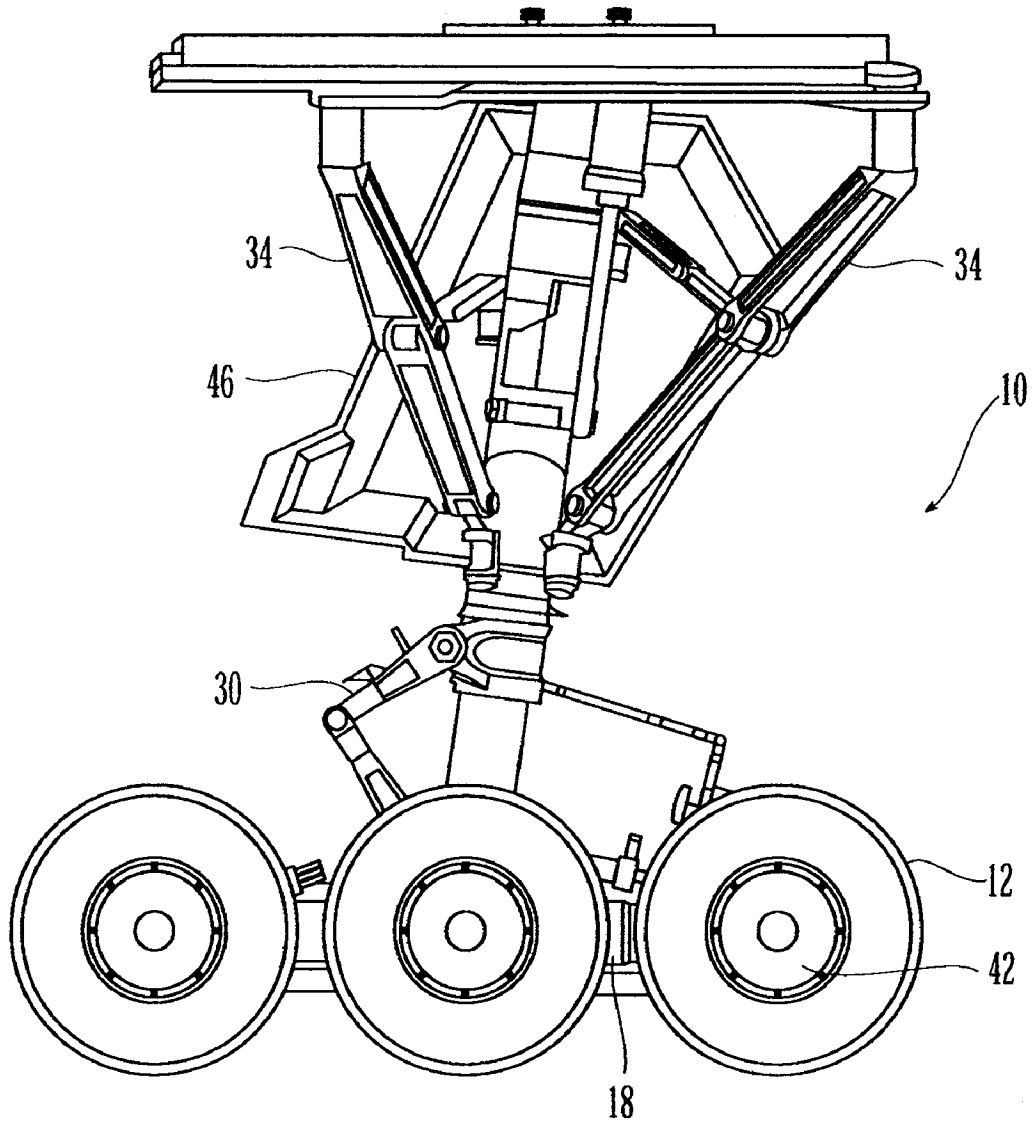

Fig. 1
(Prior Art)

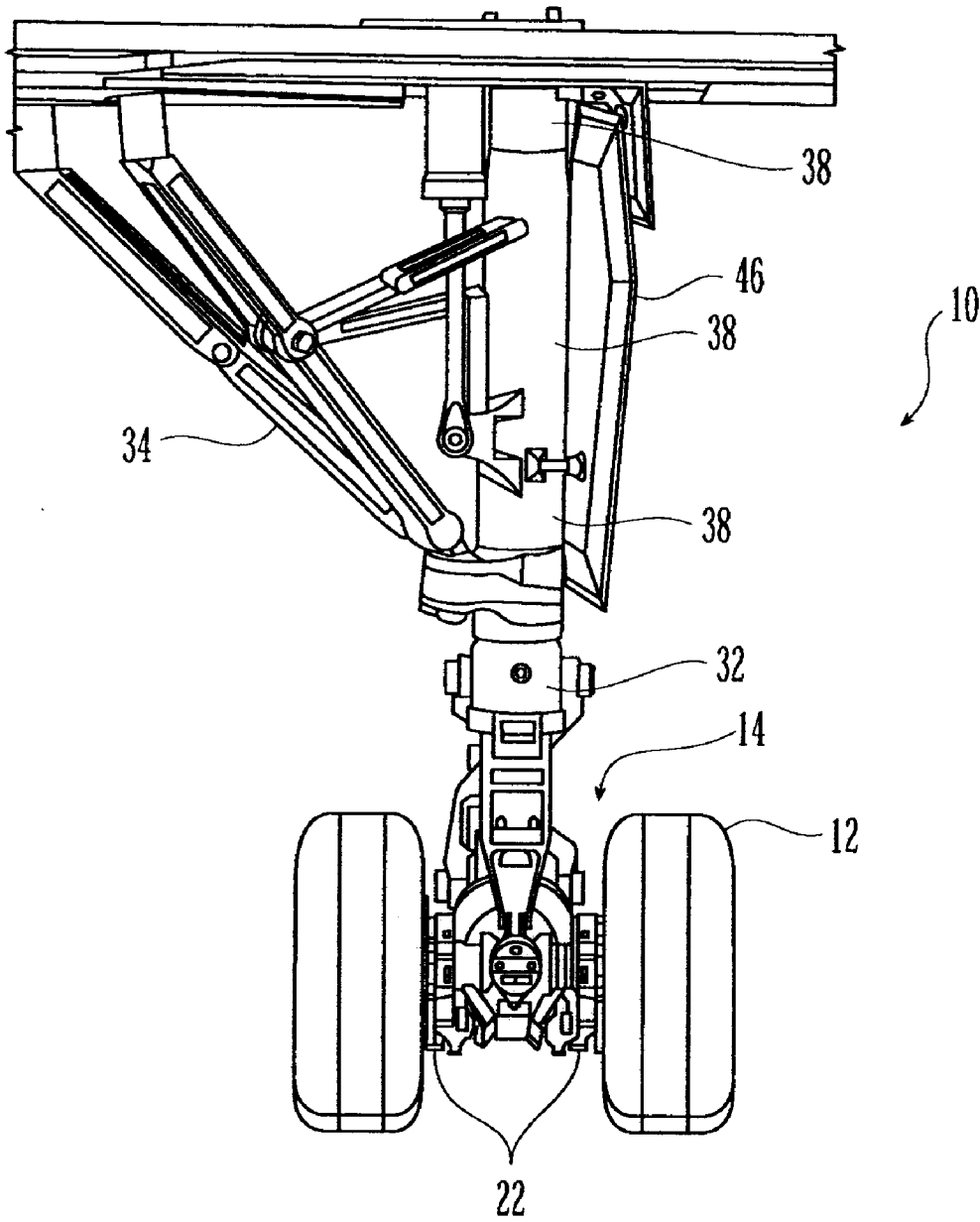

Fig. 2
(Prior Art)

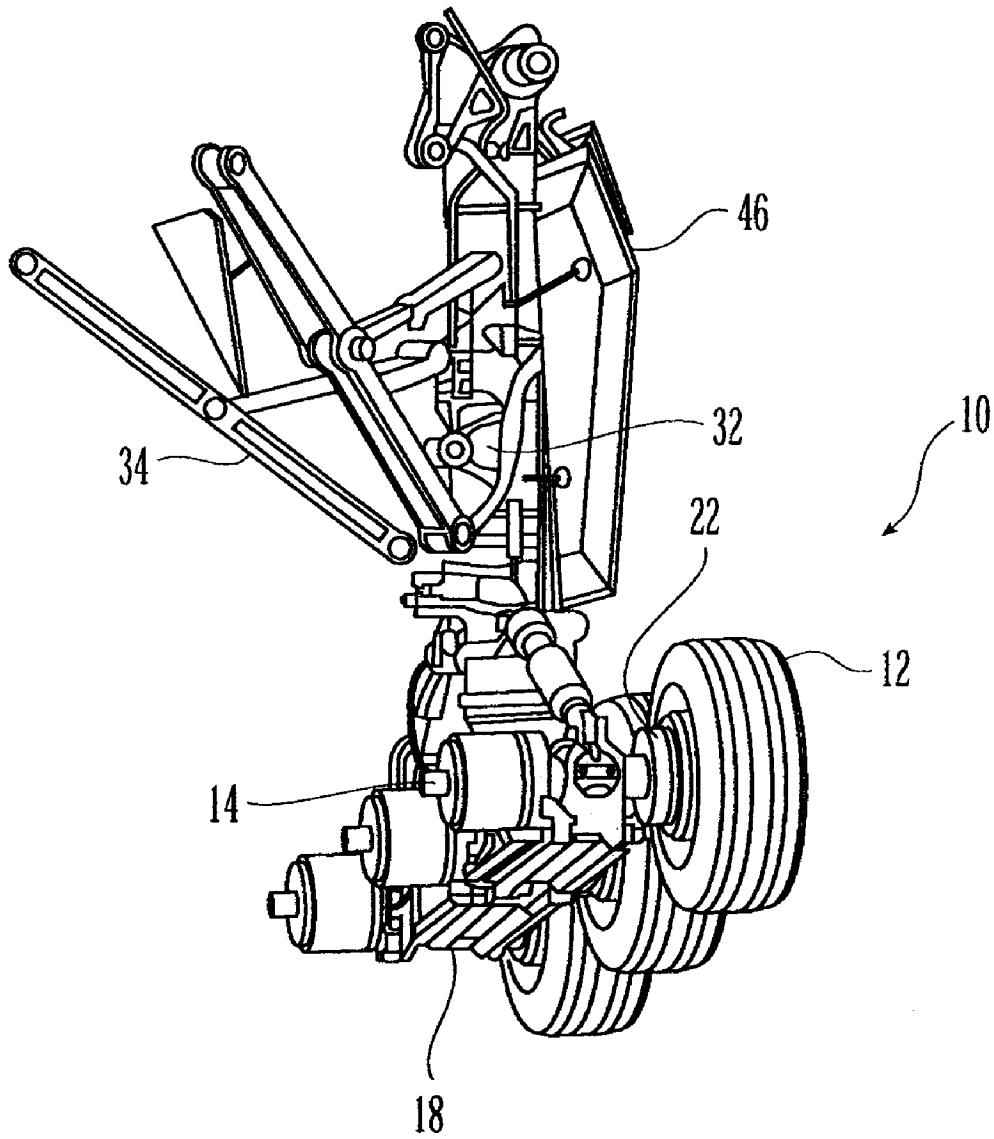

Fig. 3
(Prior Art)

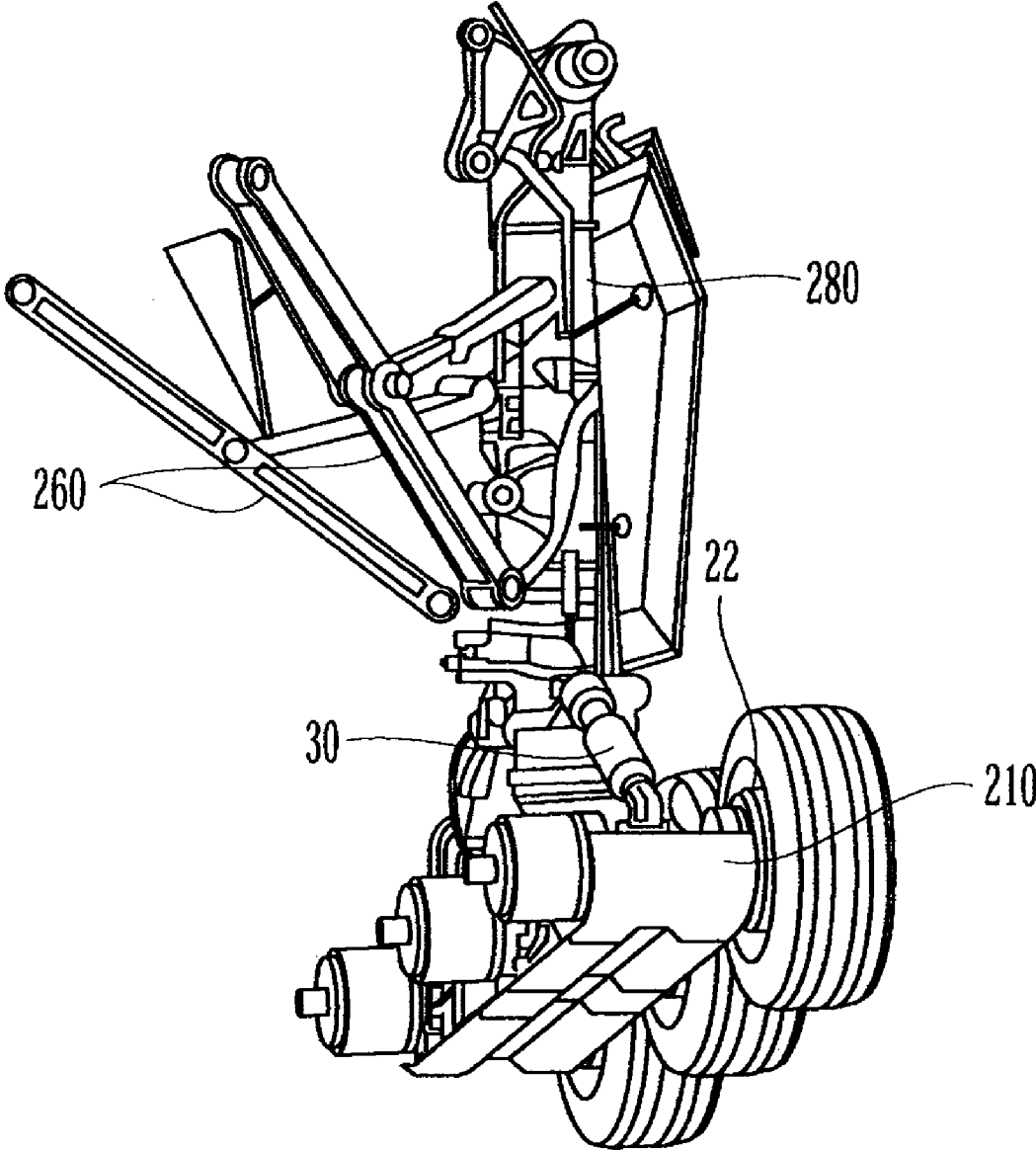

Fig. 4

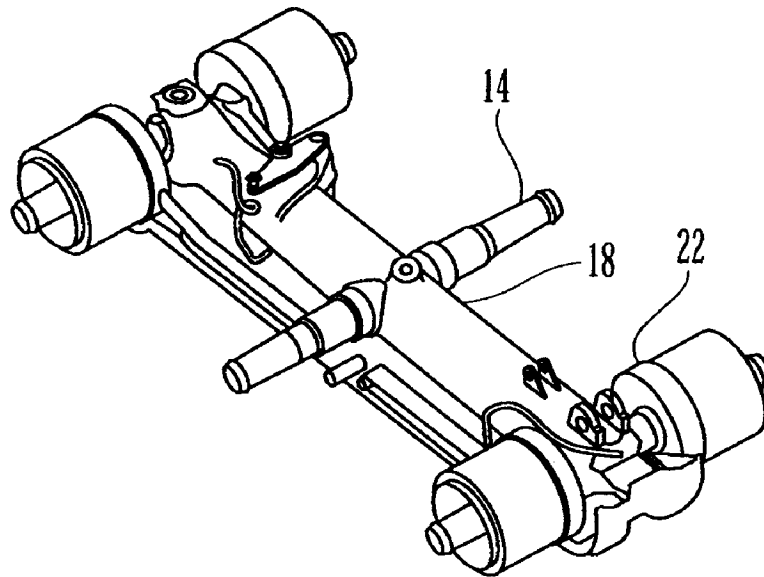

Fig. 5A

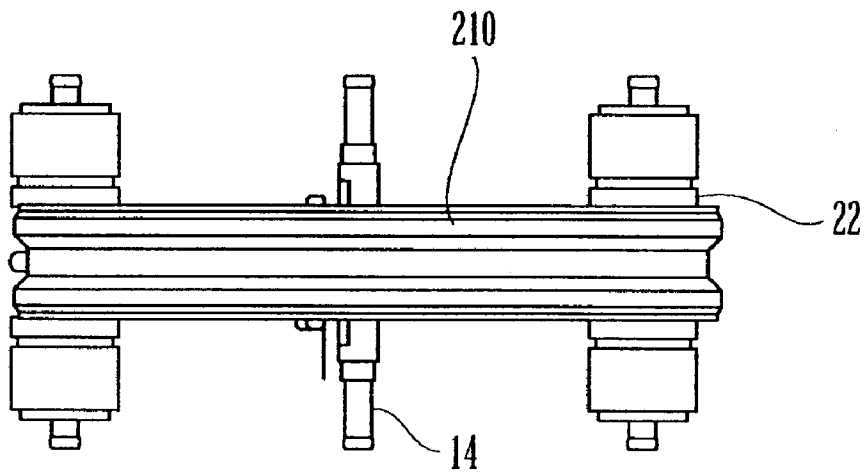

Fig. 5B

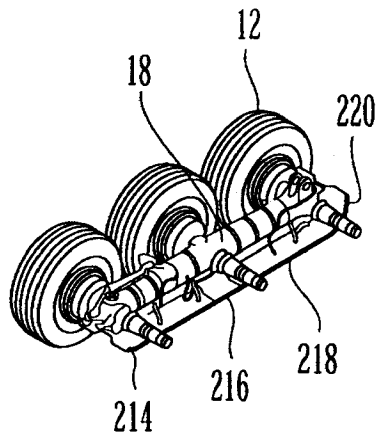

Fig. 6A

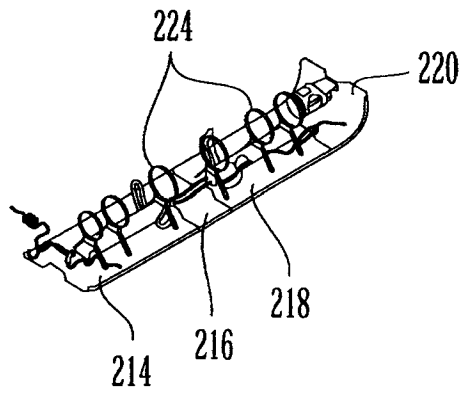

Fig. 6B

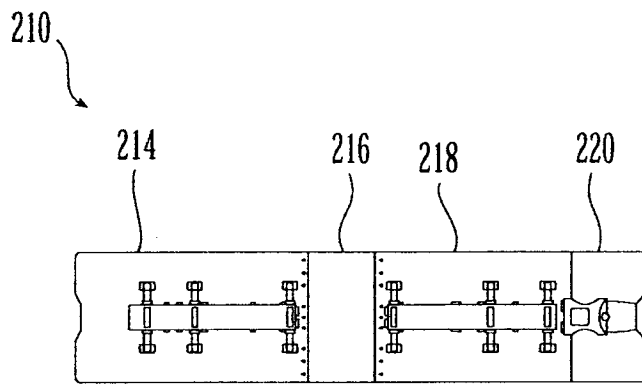

Fig. 6C

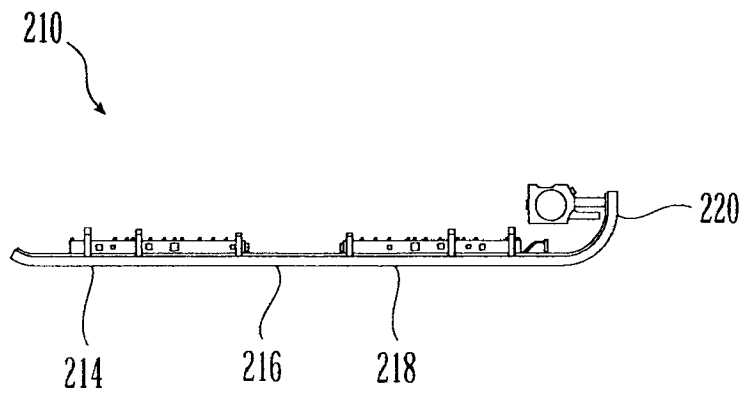

Fig. 6D

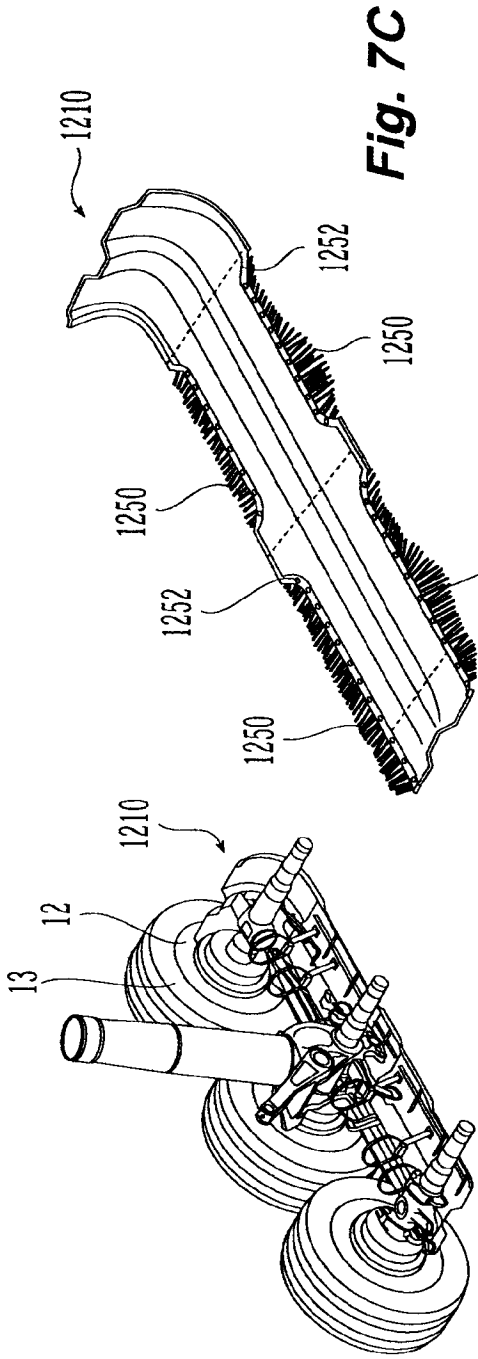

Fig. 7A

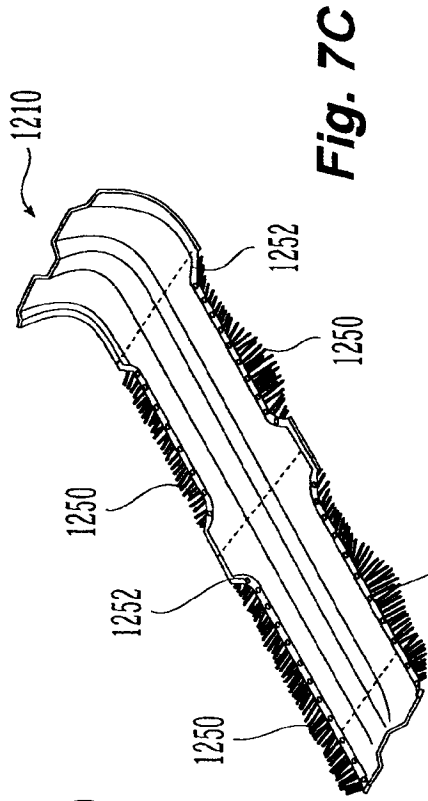

Fig. 7C

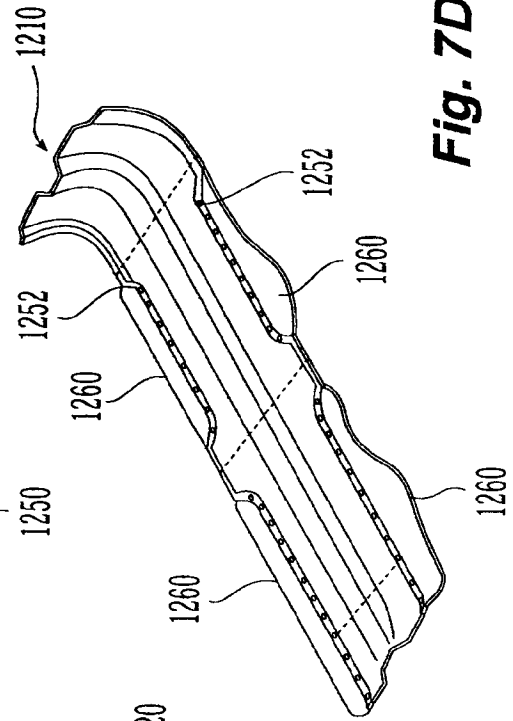

Fig. 7D

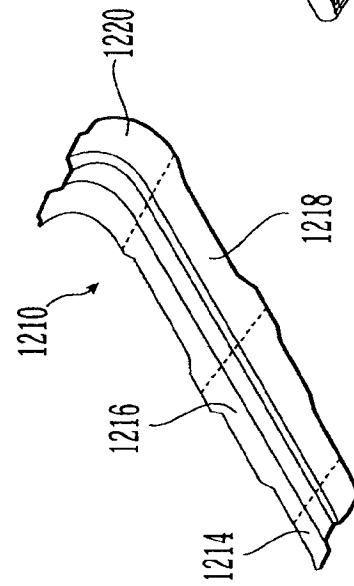

Fig. 7B

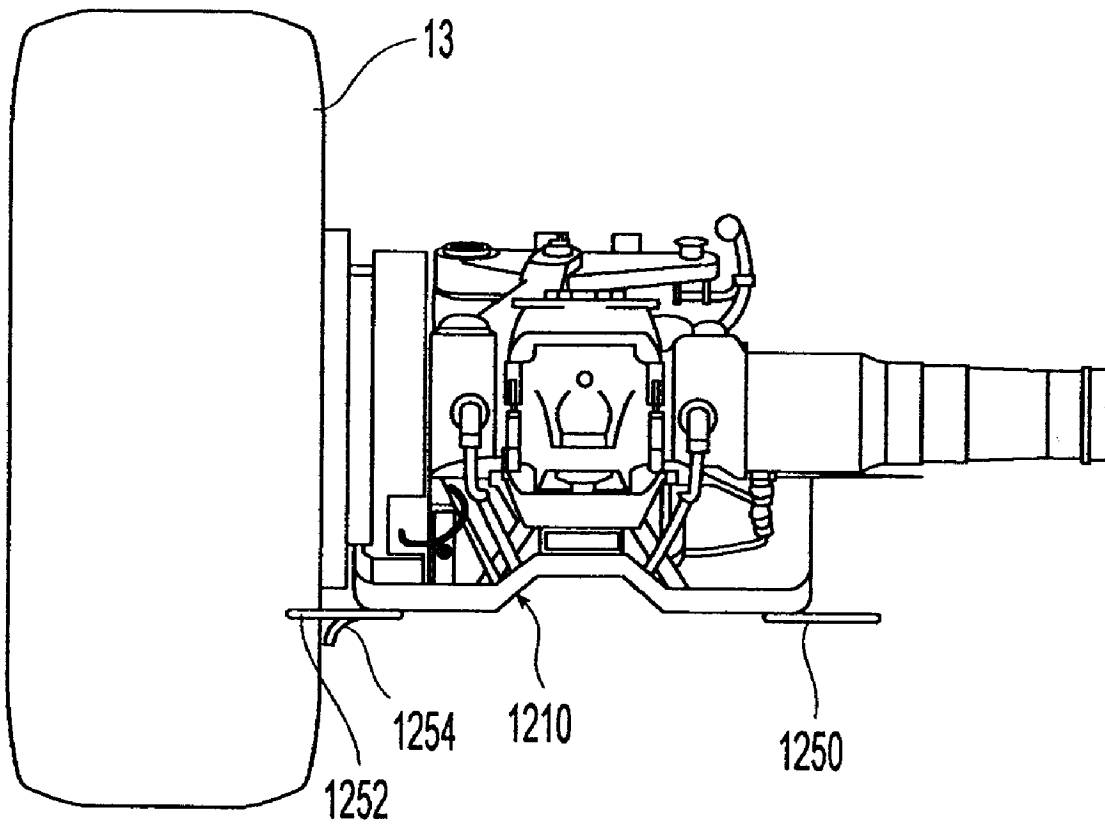

Fig. 7E

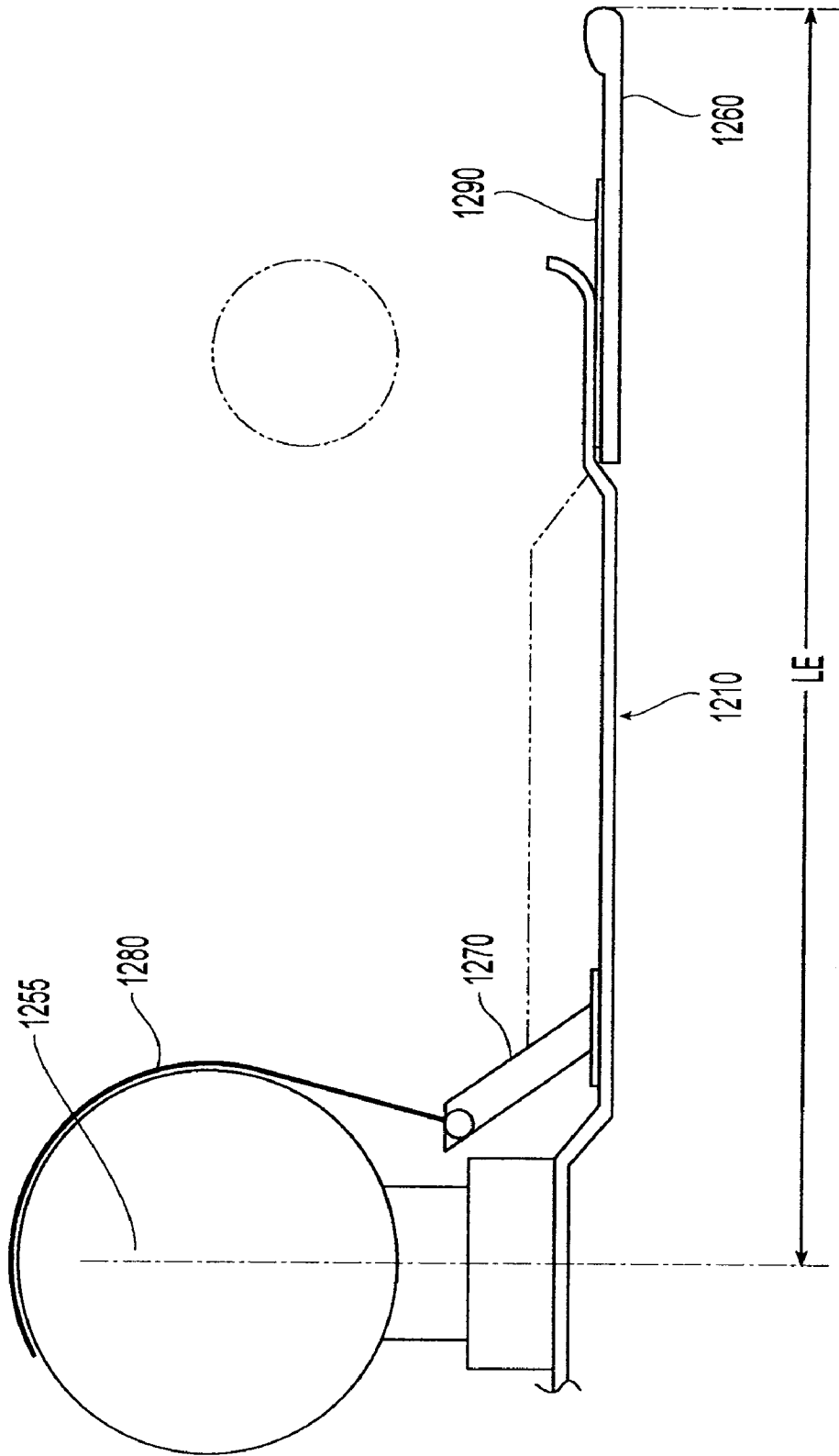

Fig. 8

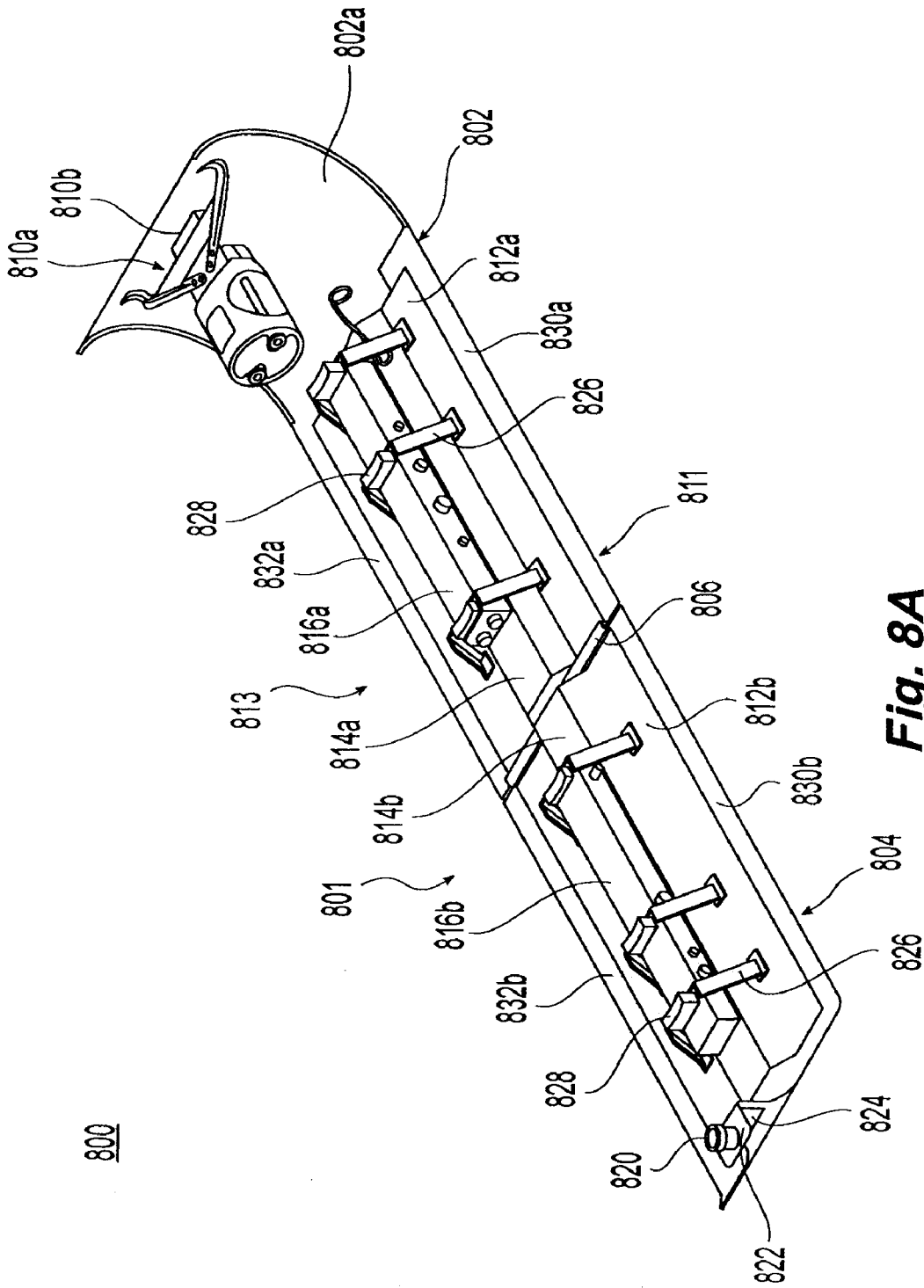

Fig. 8A

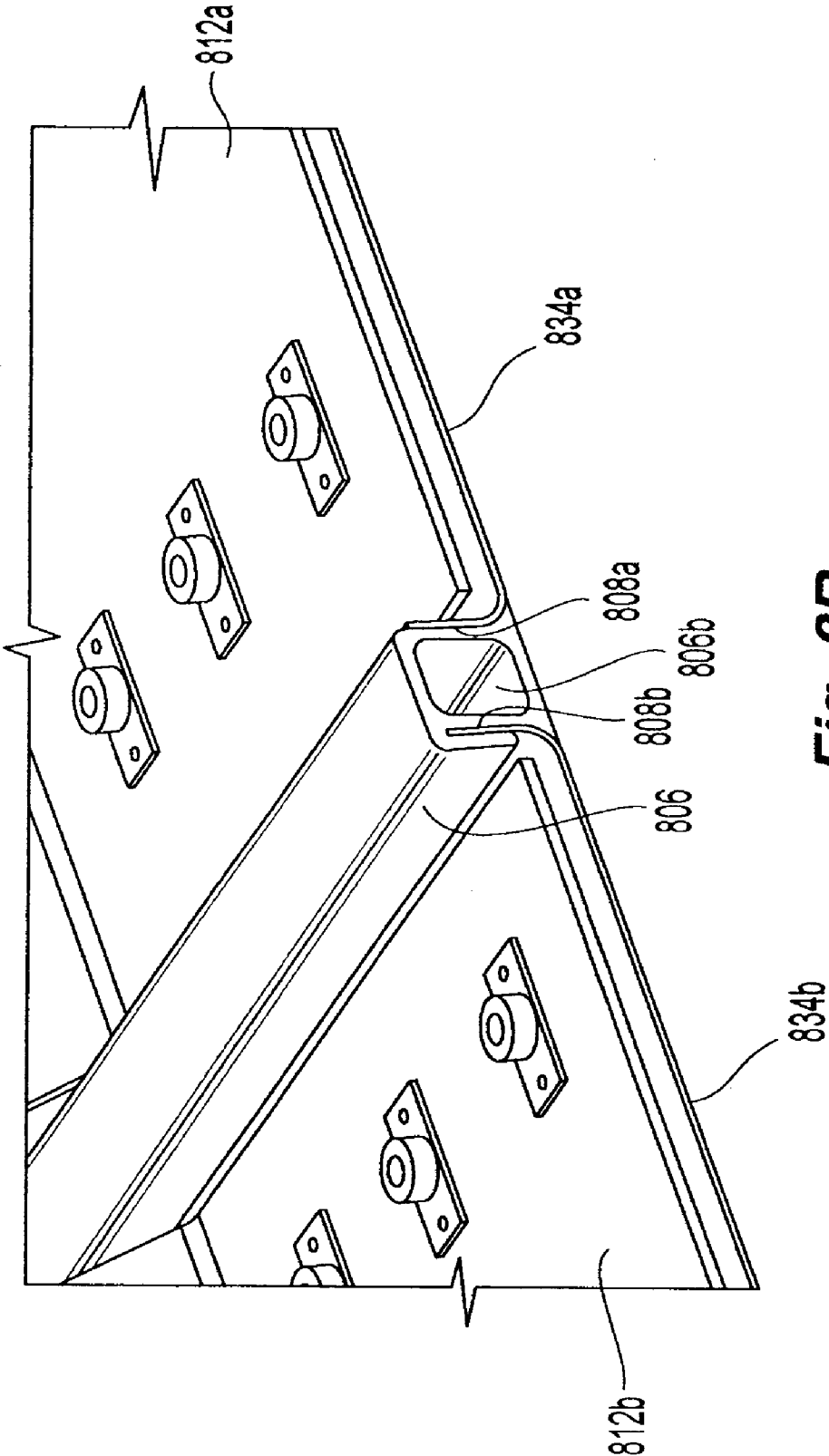

Fig. 8B

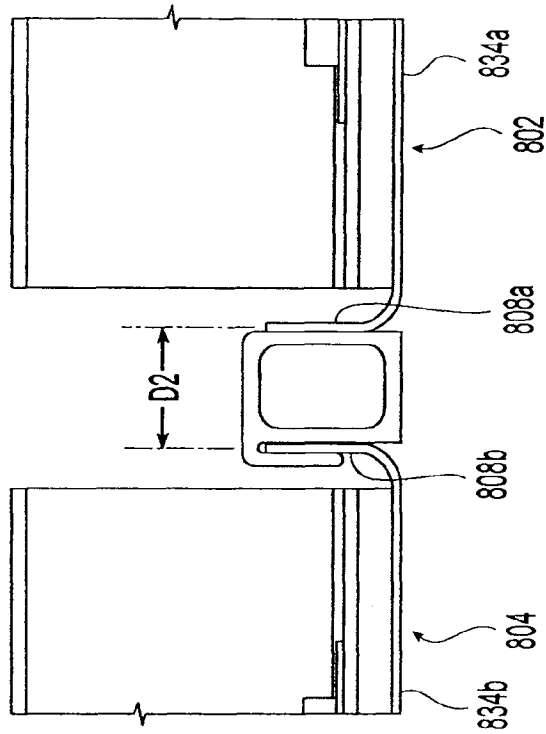

Fig. 8D

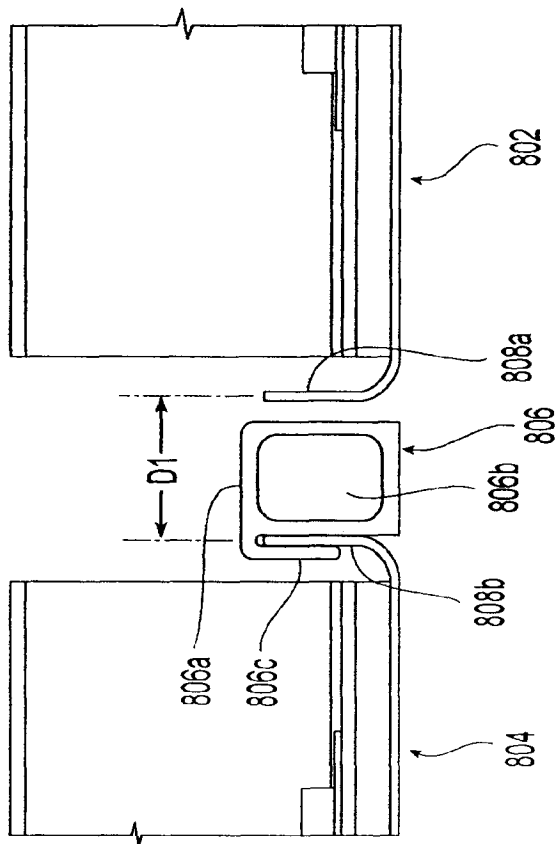

Fig. 8C

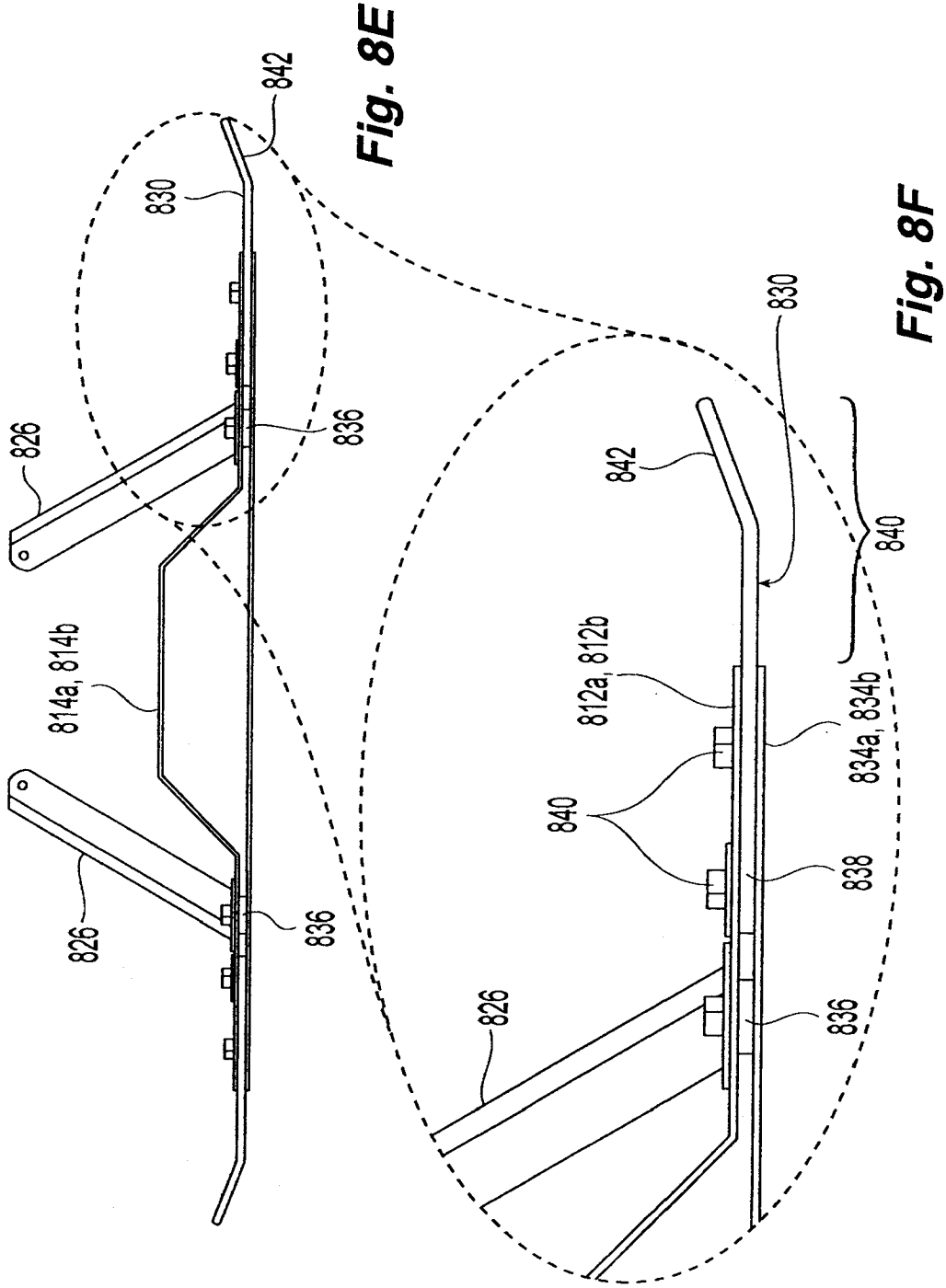

Fig. 8E

Fig. 8F

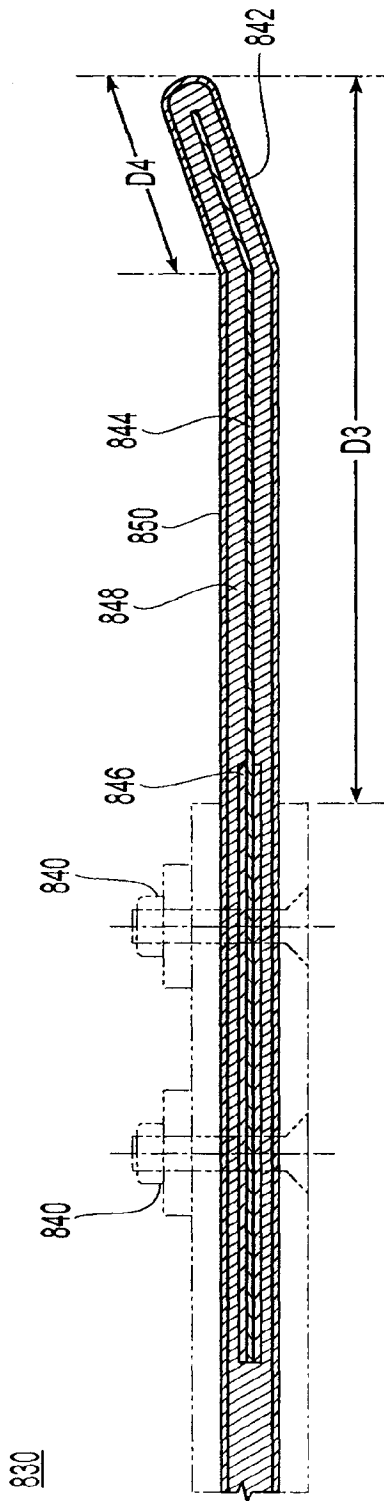

Fig. 8G

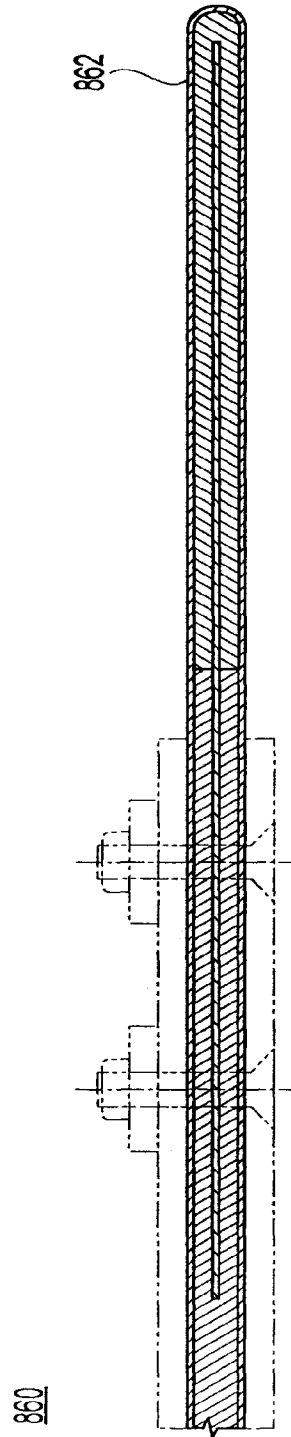

Fig. 8H

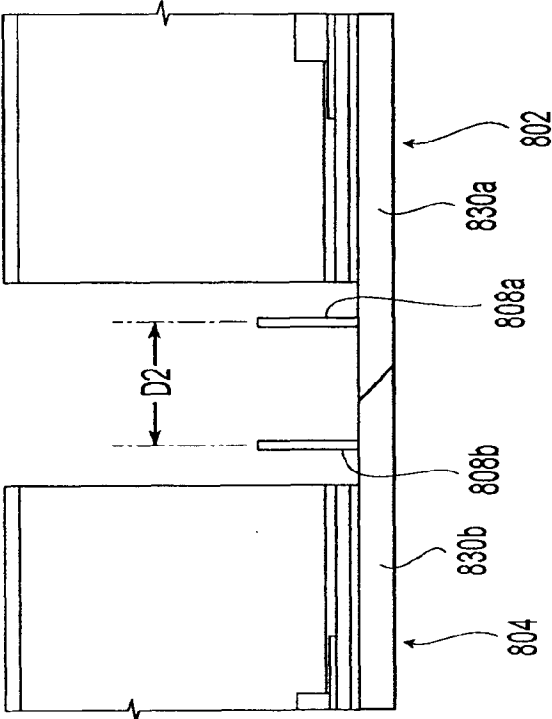

Fig. 8I

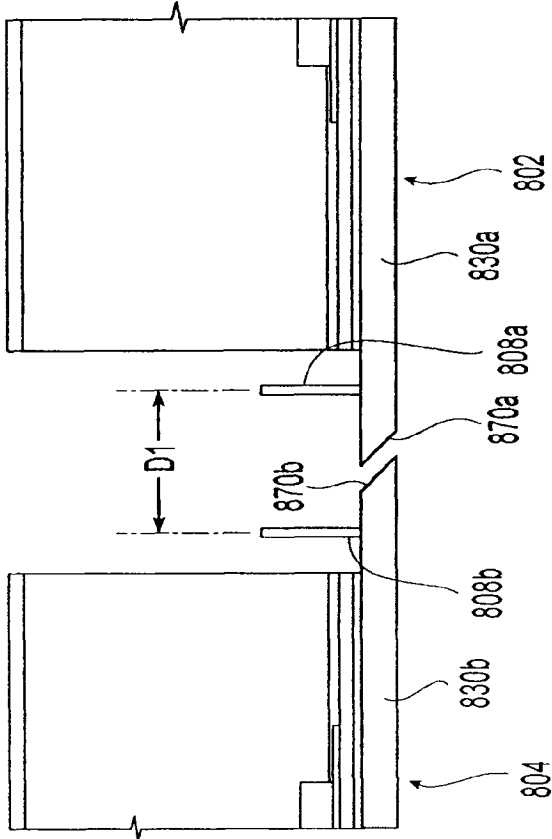

Fig. 8J

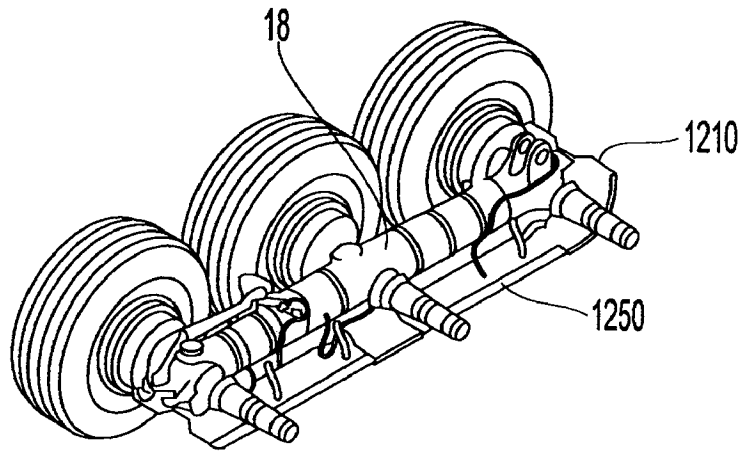

Fig. 9A

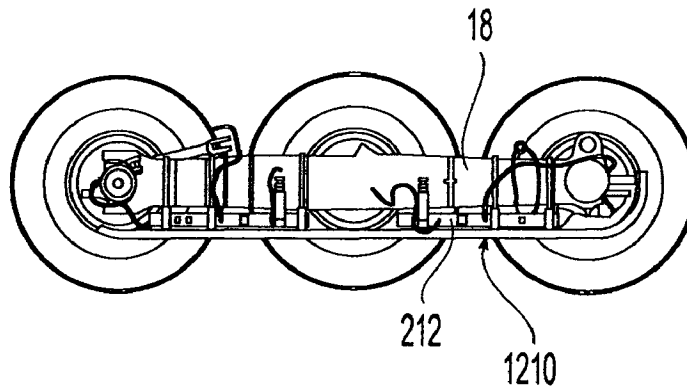

Fig. 9B

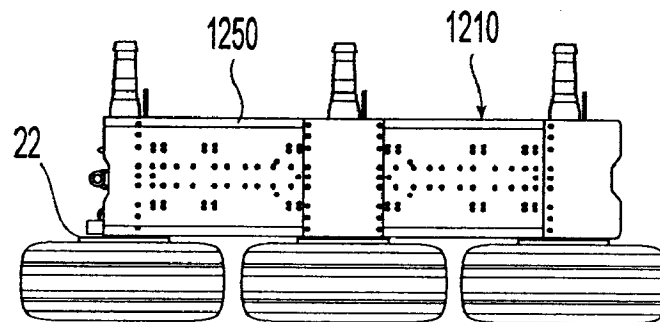

Fig. 9C

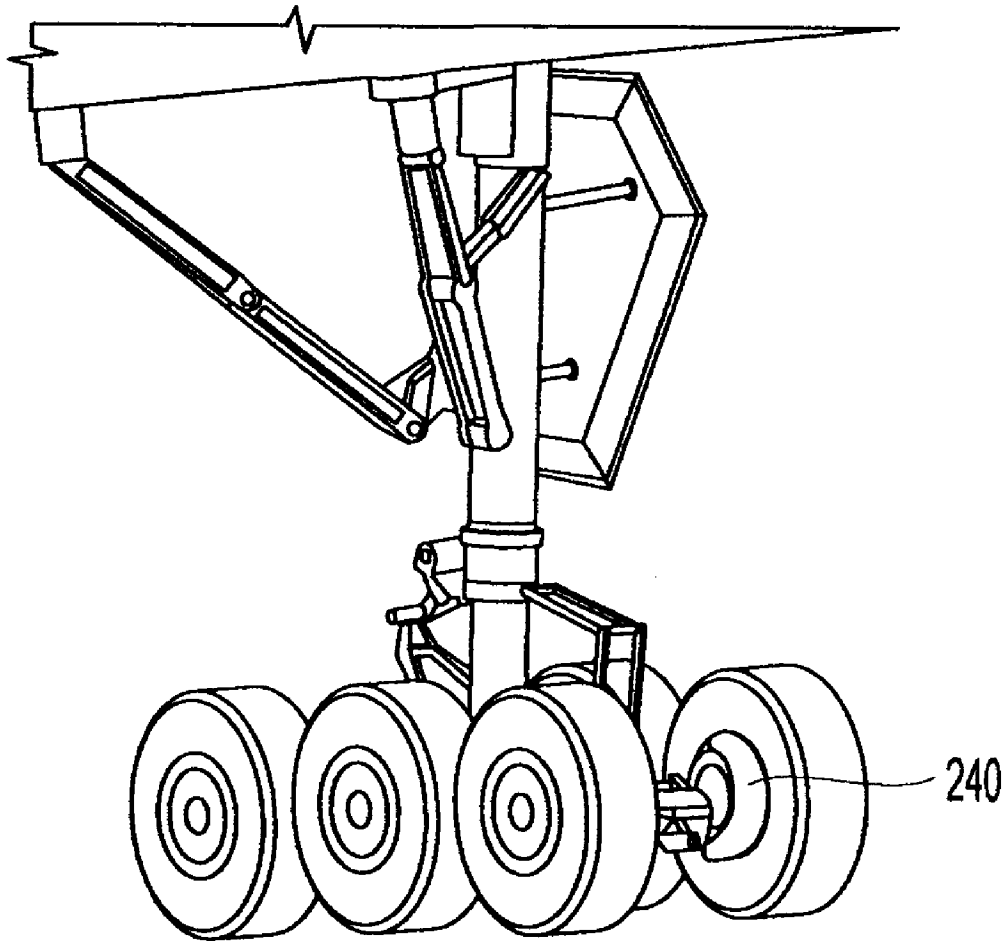

Fig. 10

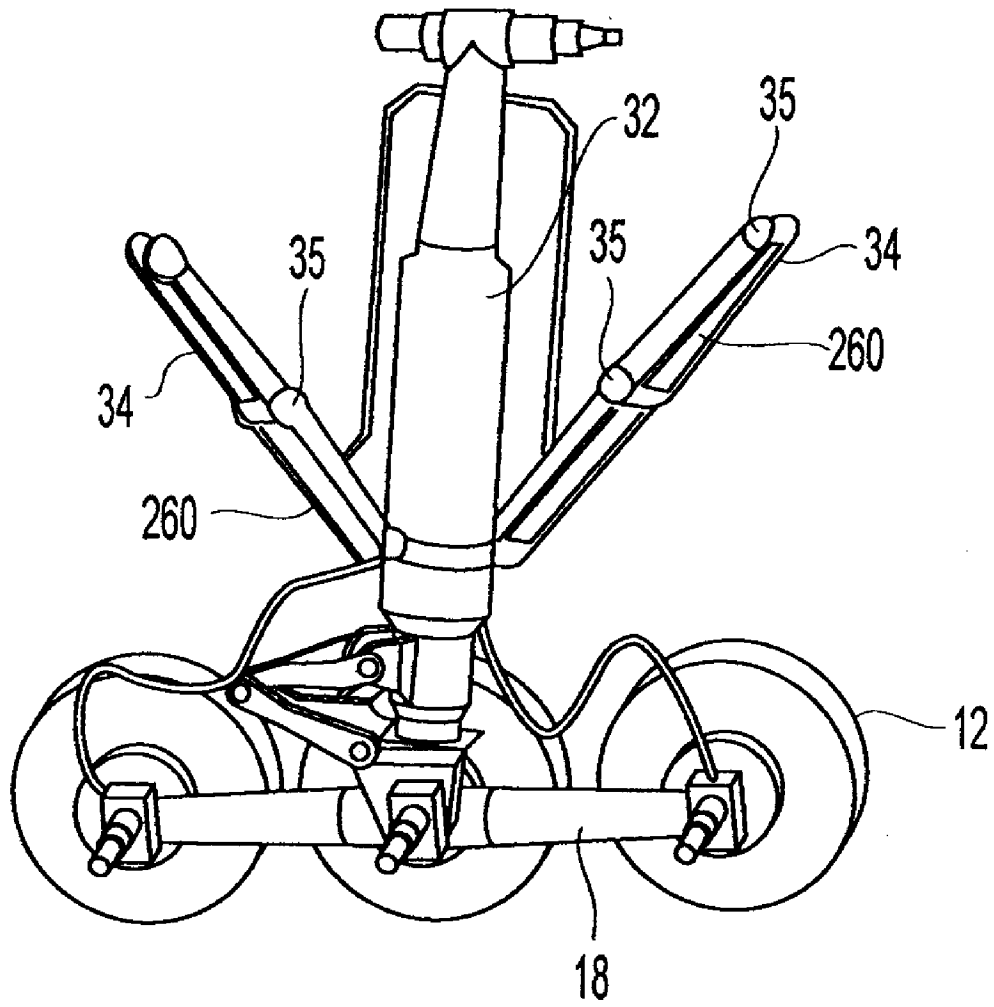

Fig. 11

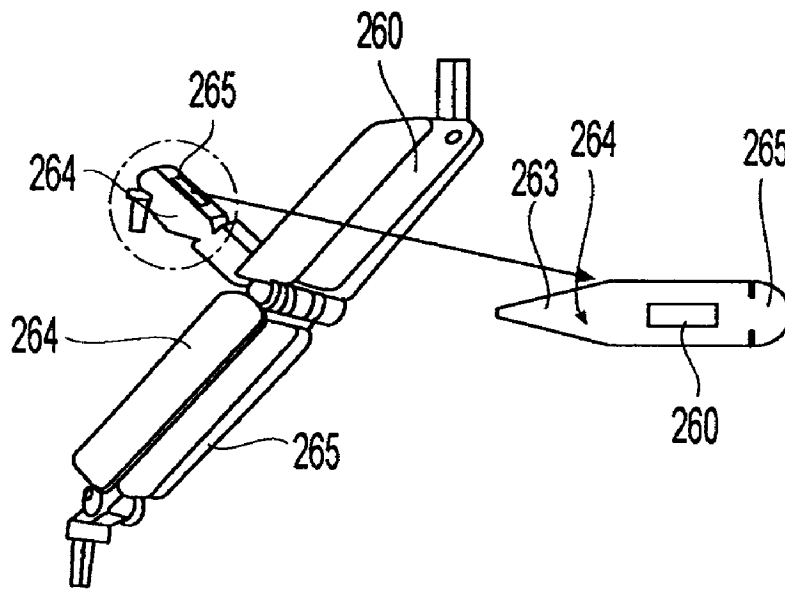

Fig. 12A

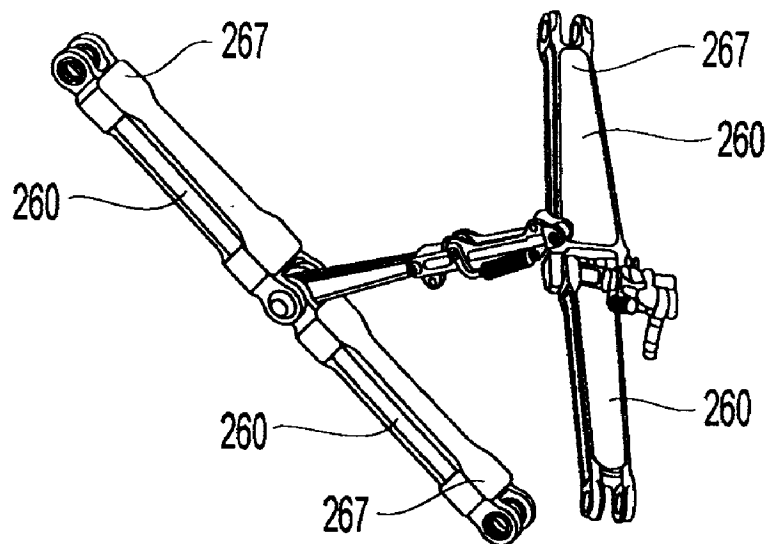

Fig. 12B

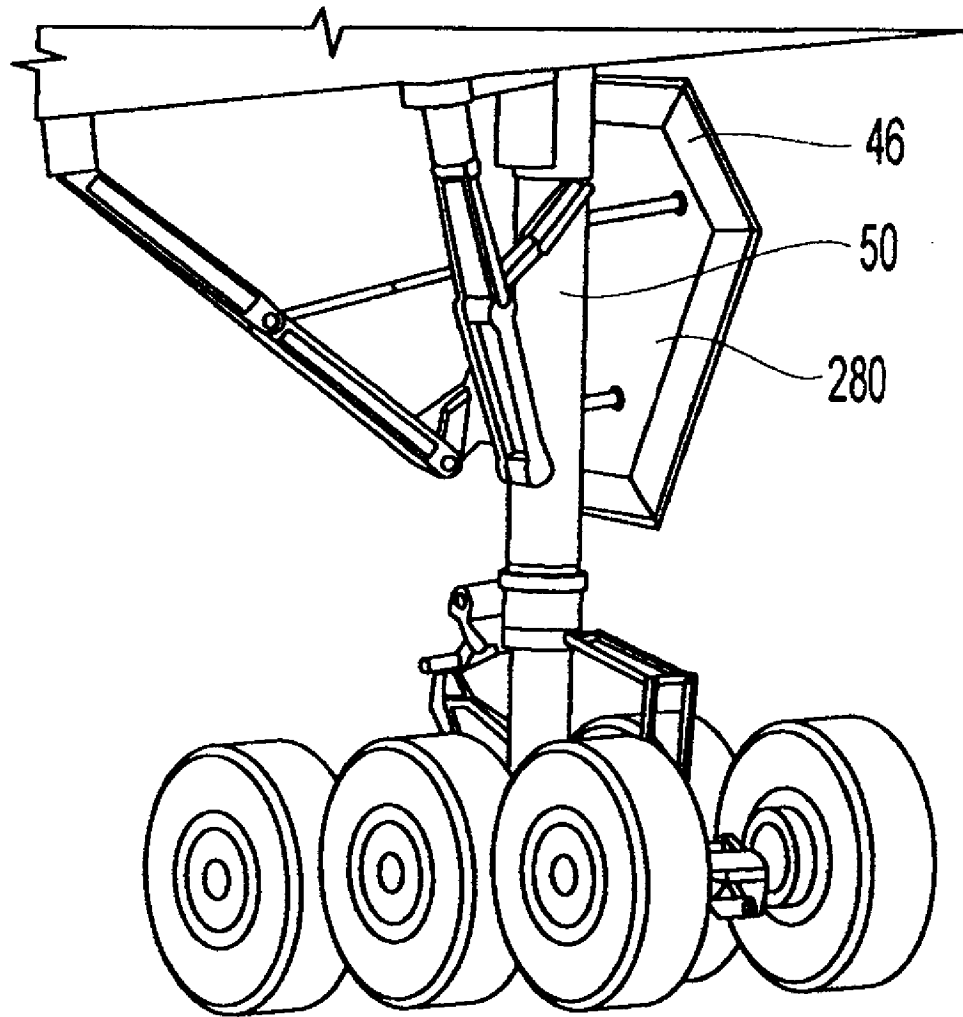

Fig. 13A

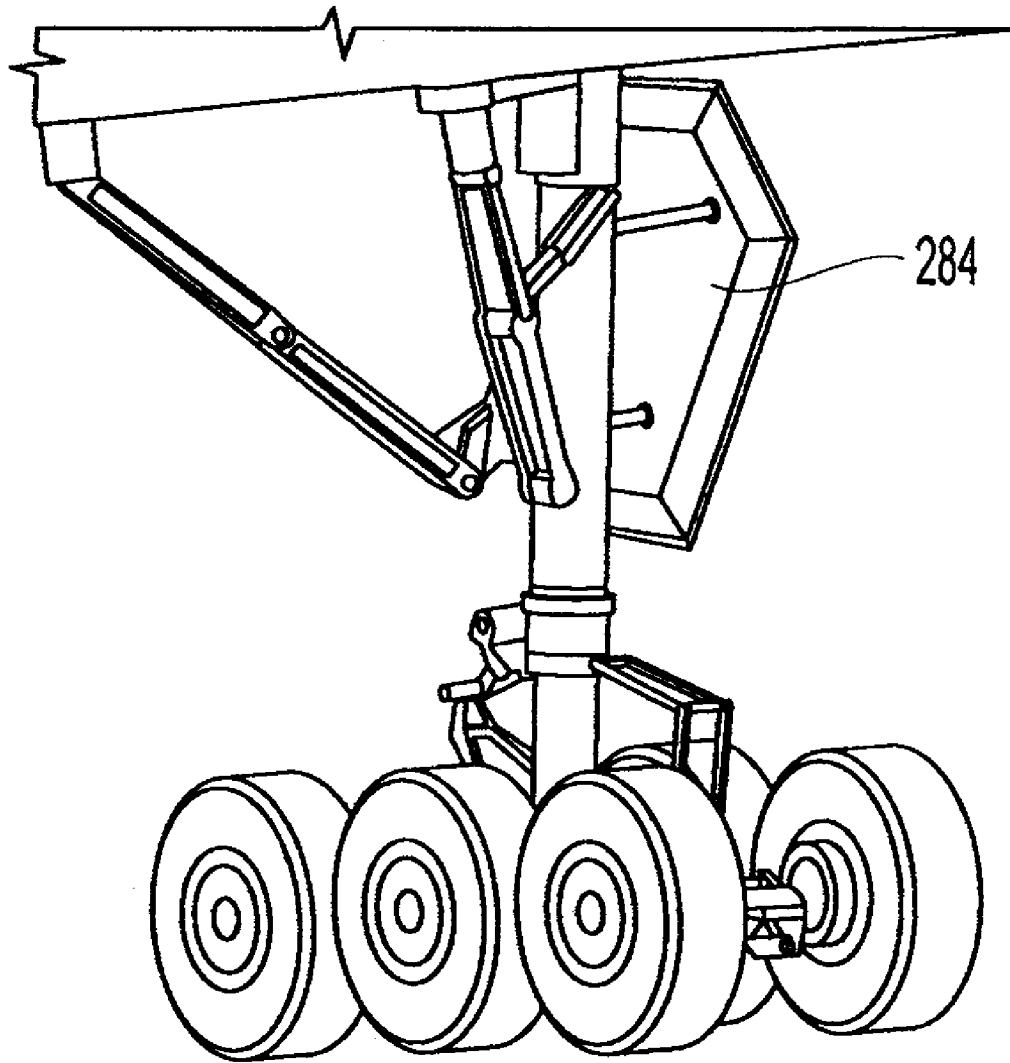

Fig. 13B

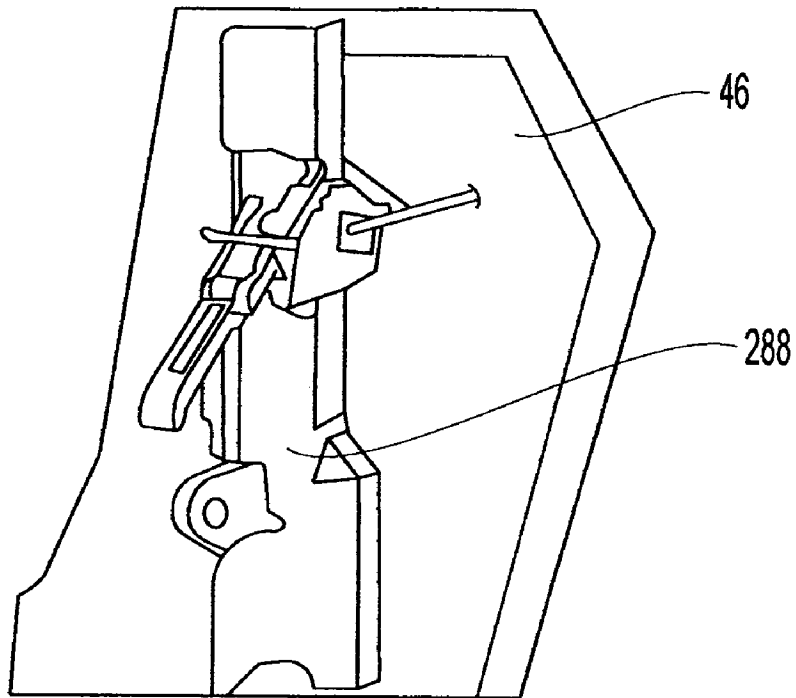

Fig. 14A

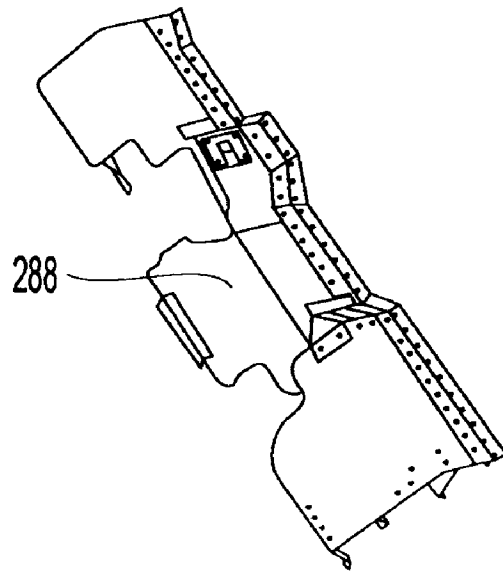

Fig. 14B

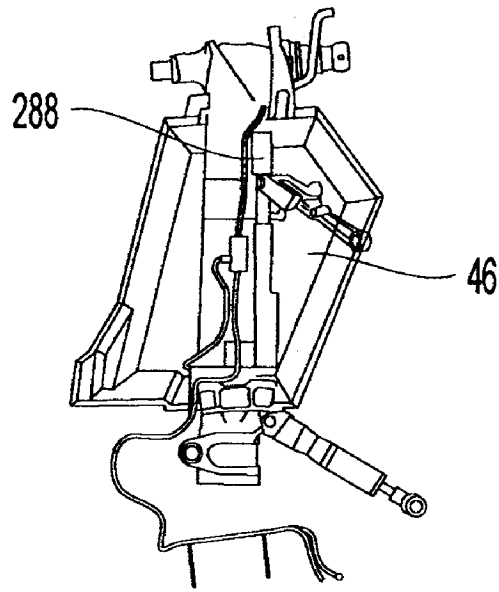

Fig. 14C

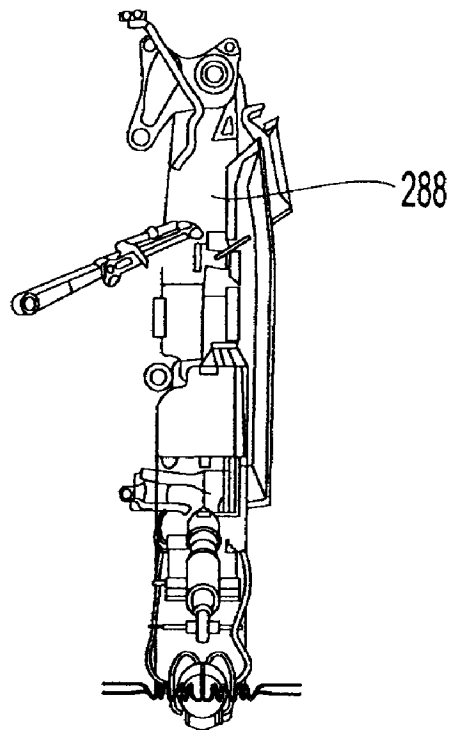

Fig. 14D

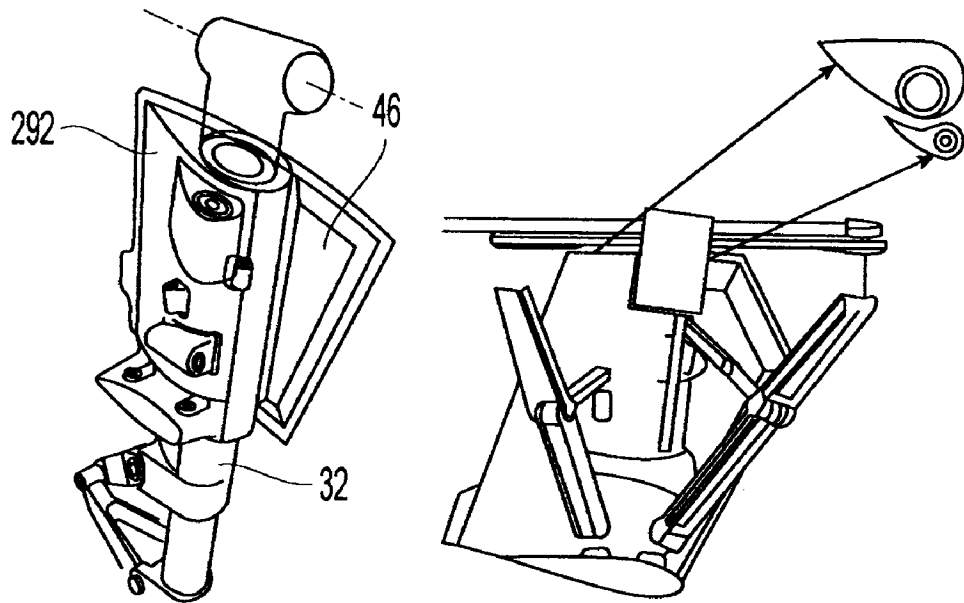

Fig. 15

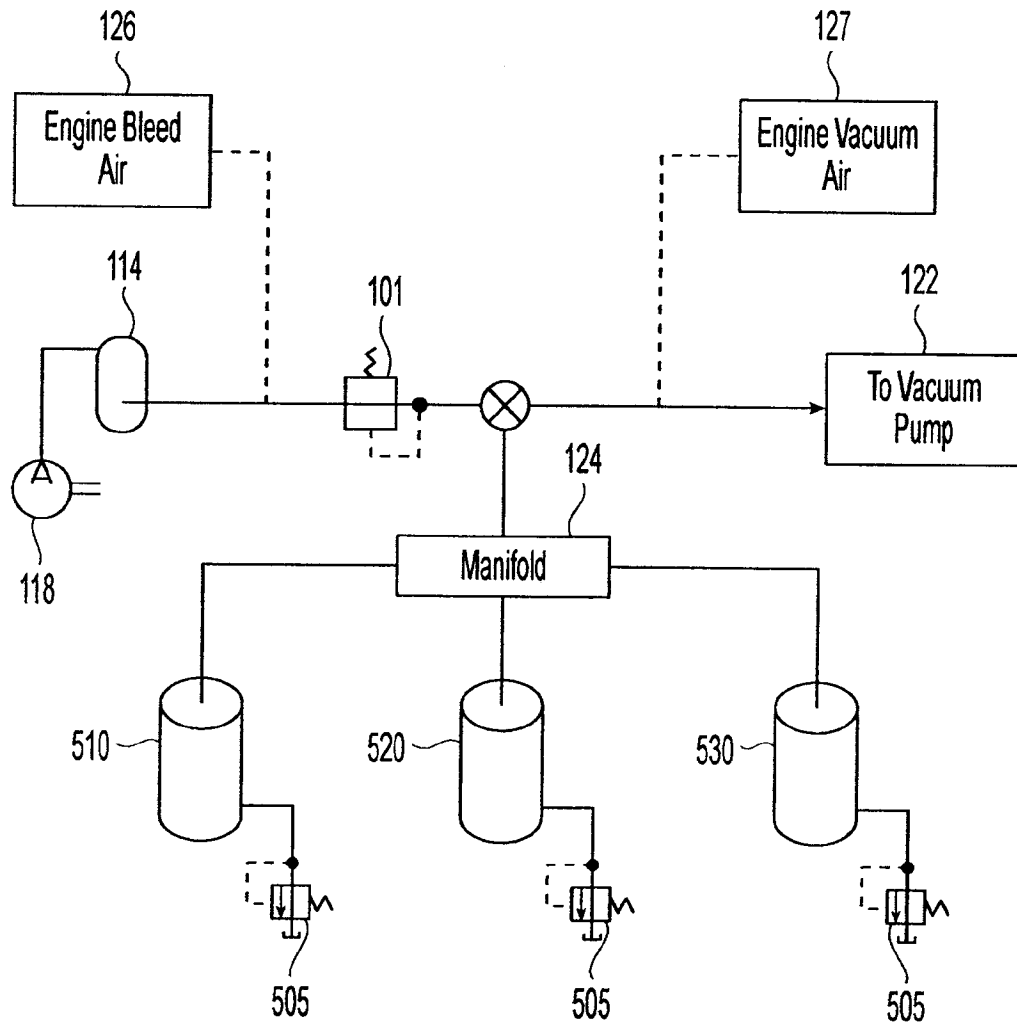

Fig. 16A

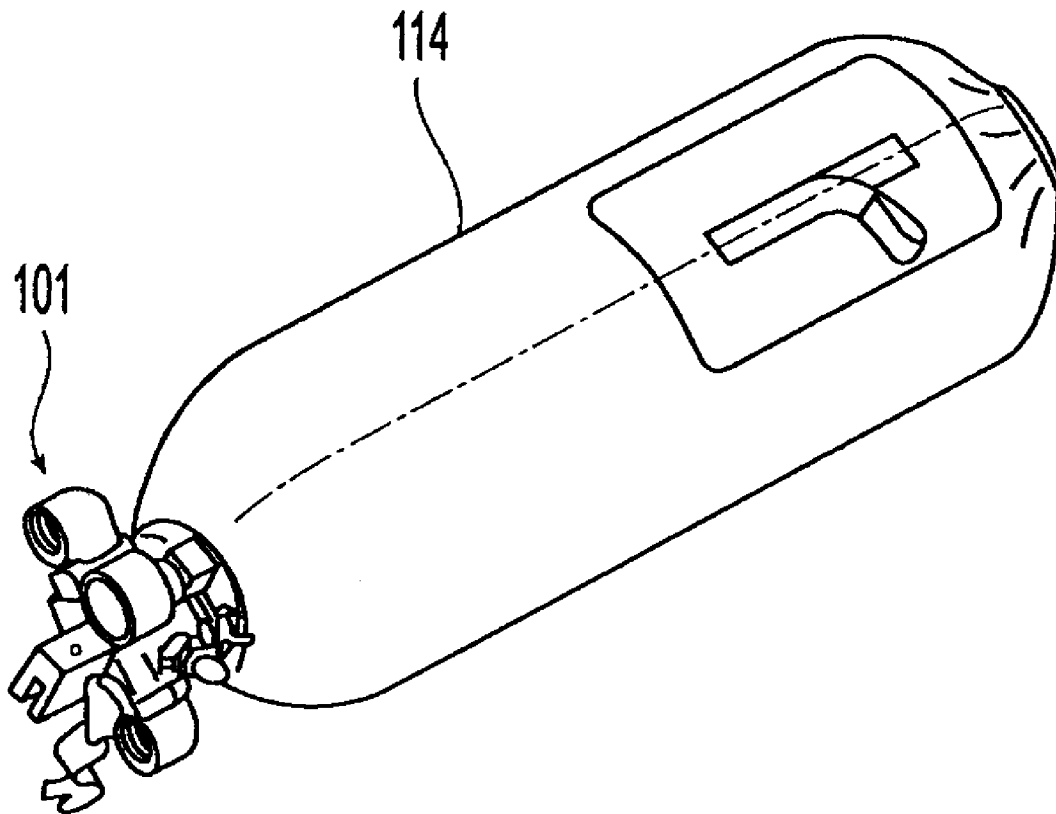

Fig. 16B

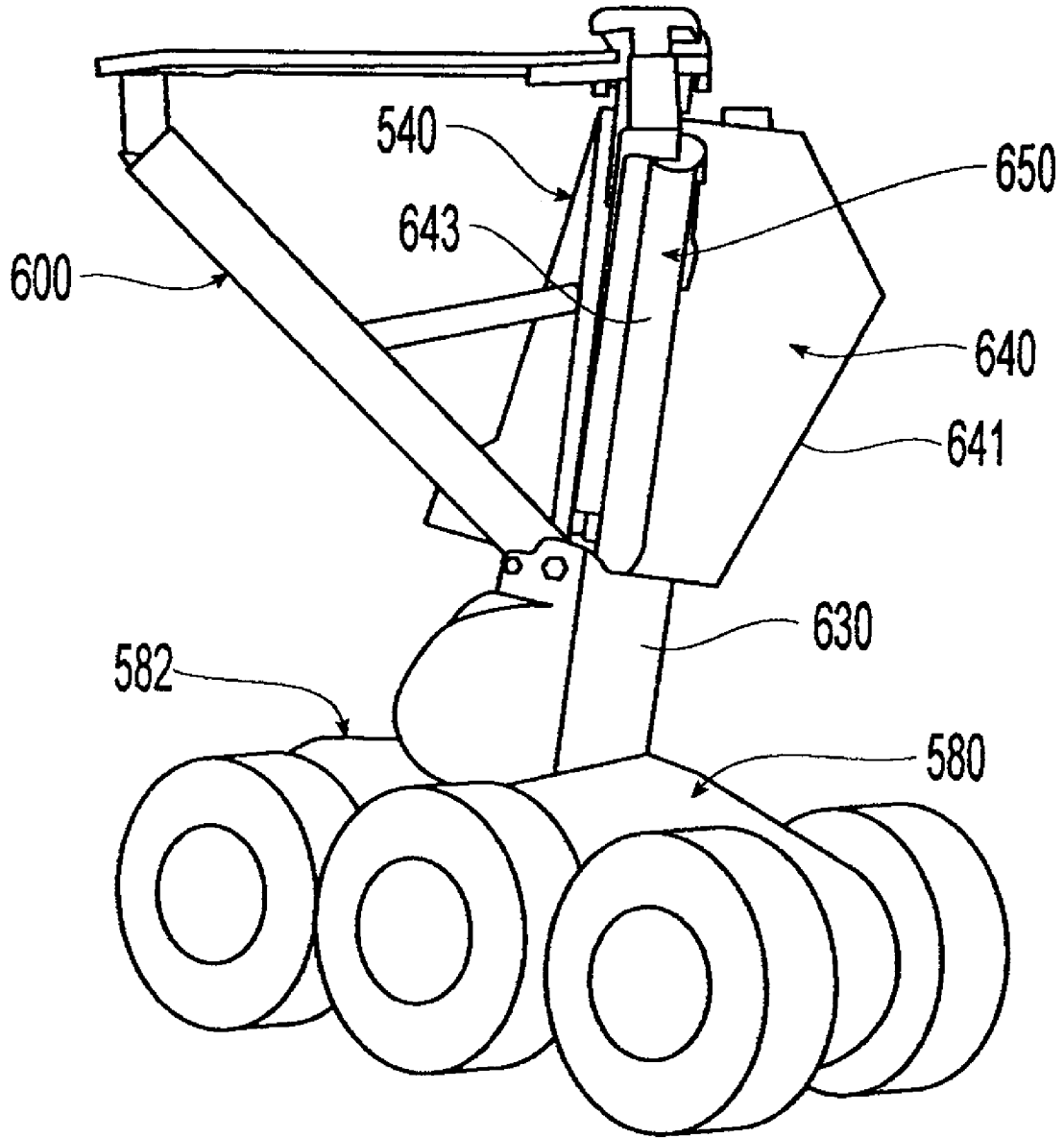

Fig. 17

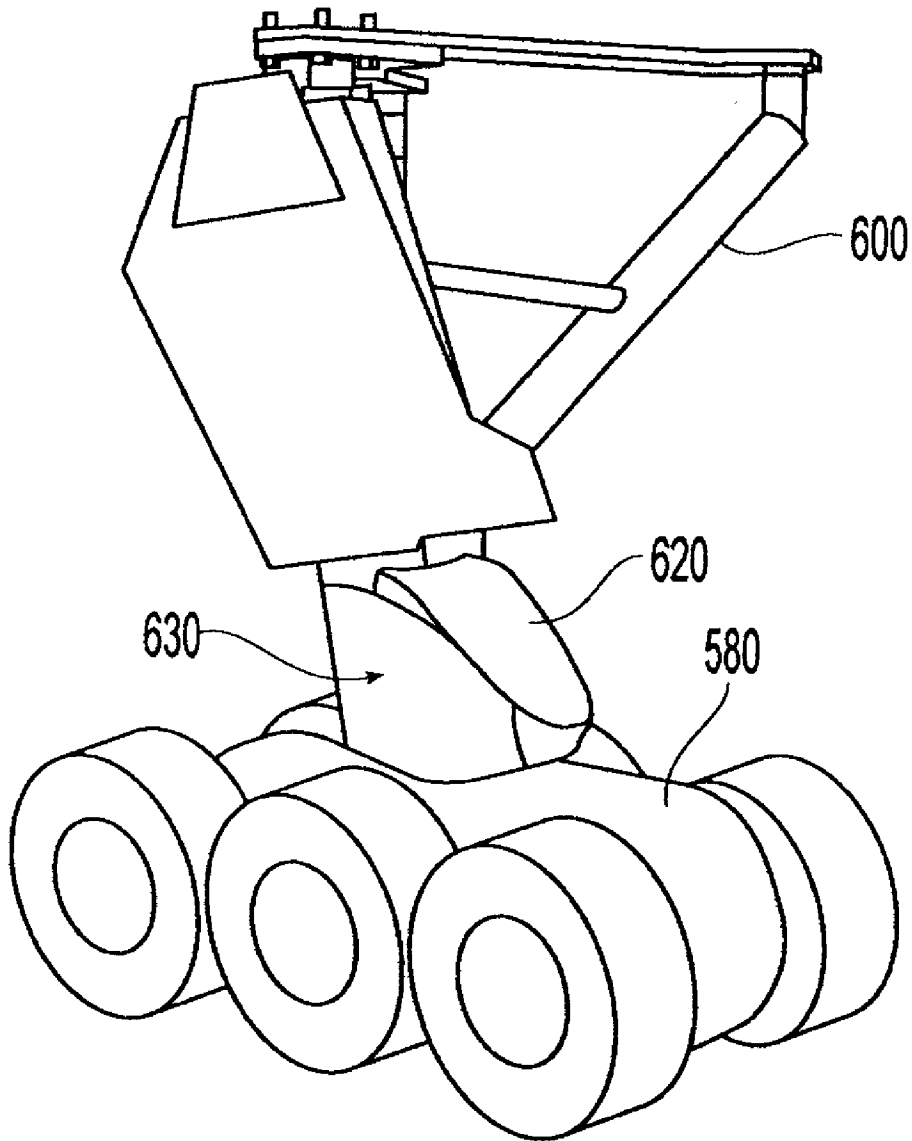

Fig. 18

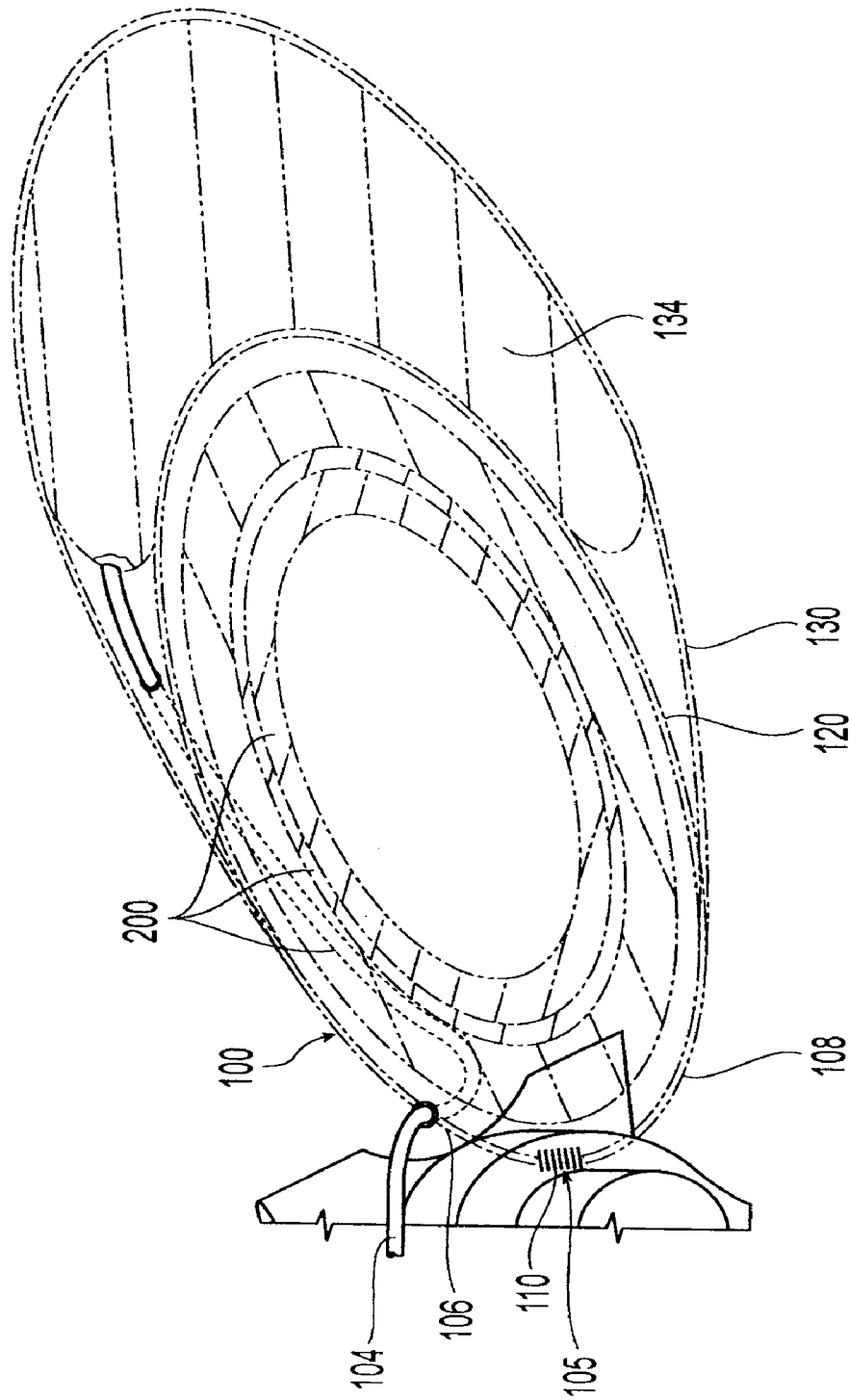

Fig. 19

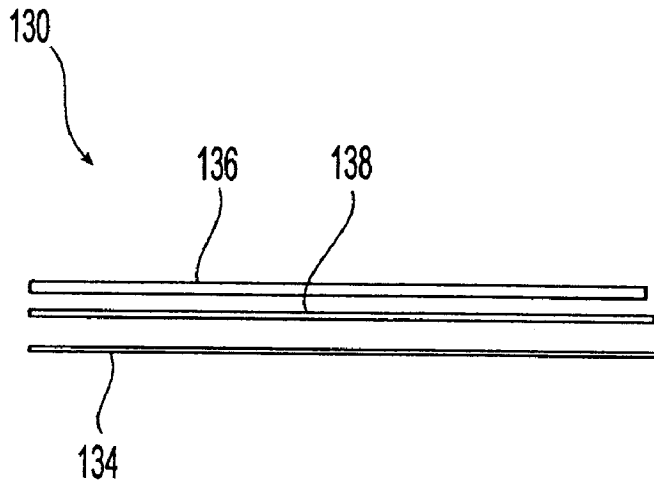

Fig. 20

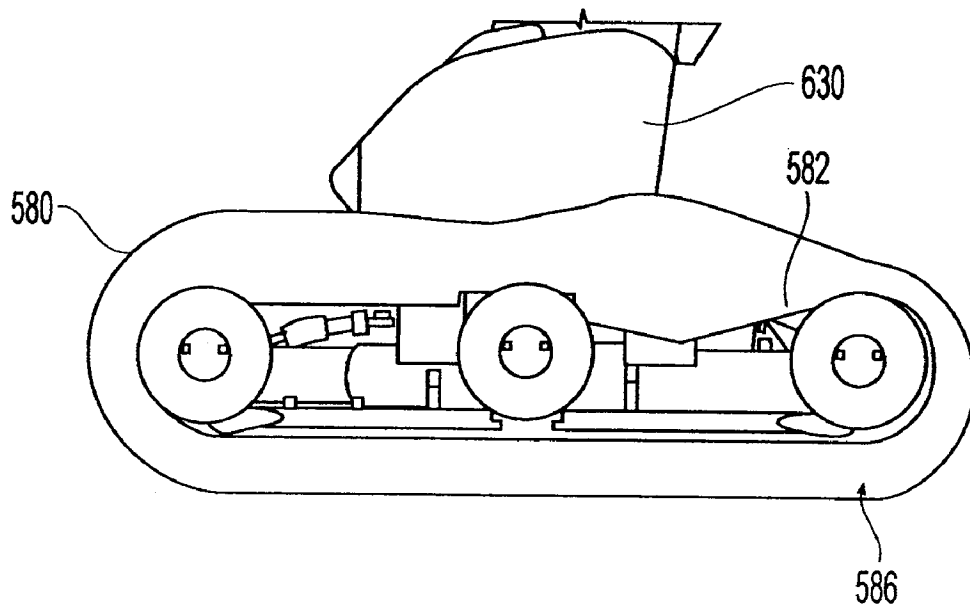

Fig. 21

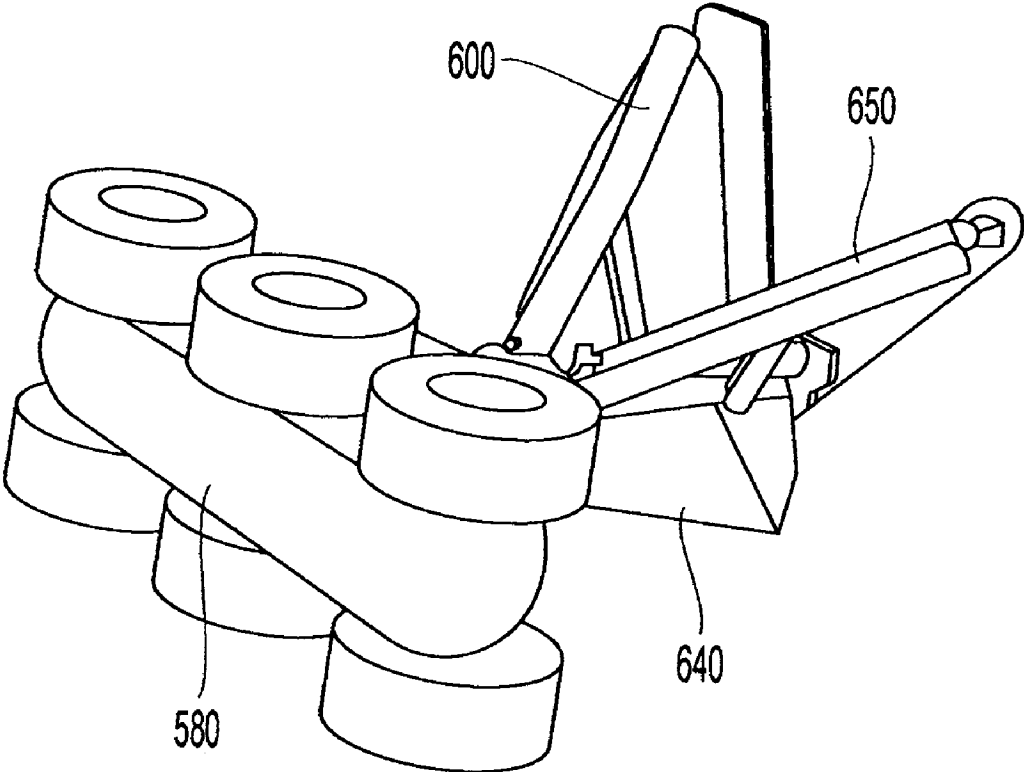

Fig. 22

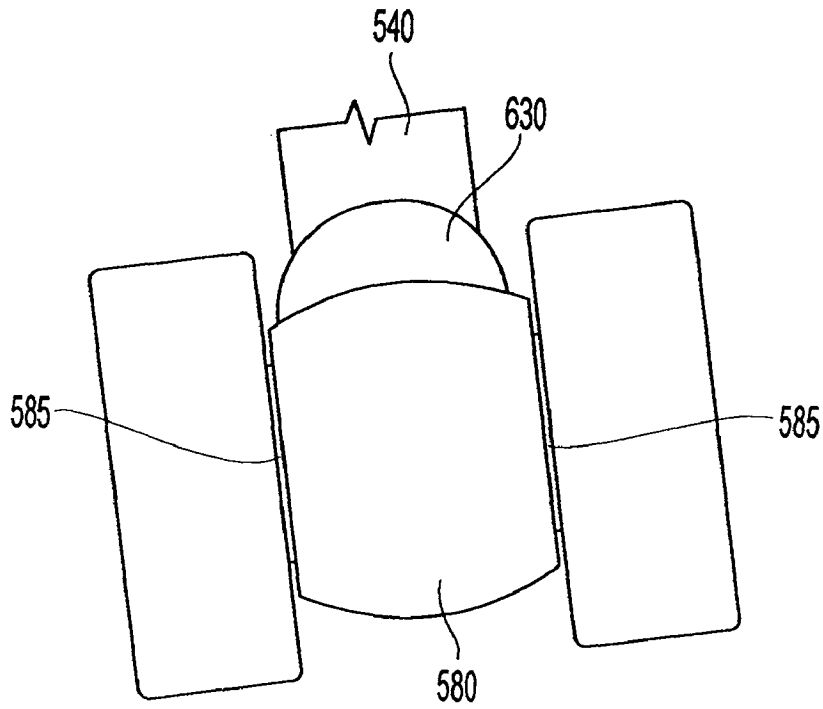

Fig. 23

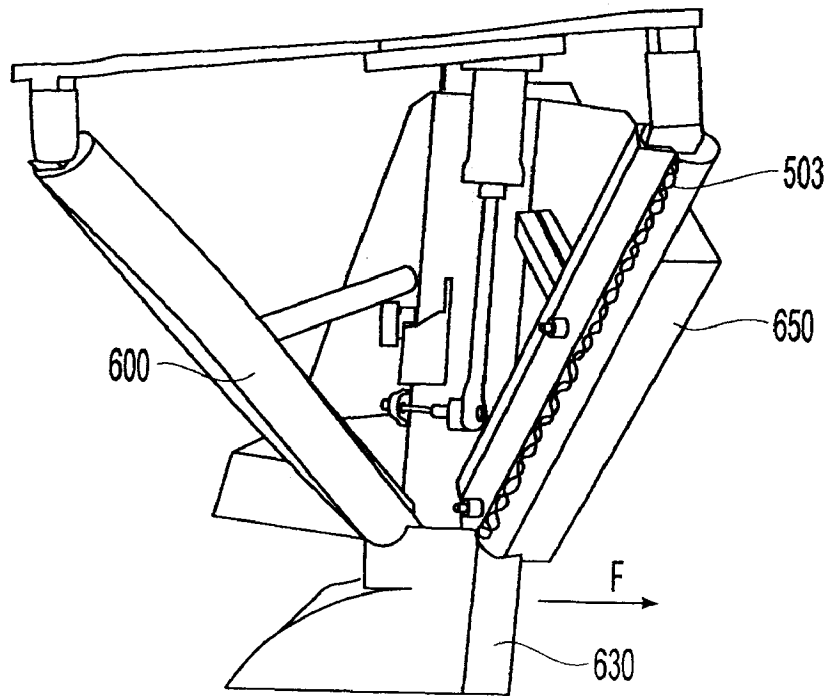

Fig. 24

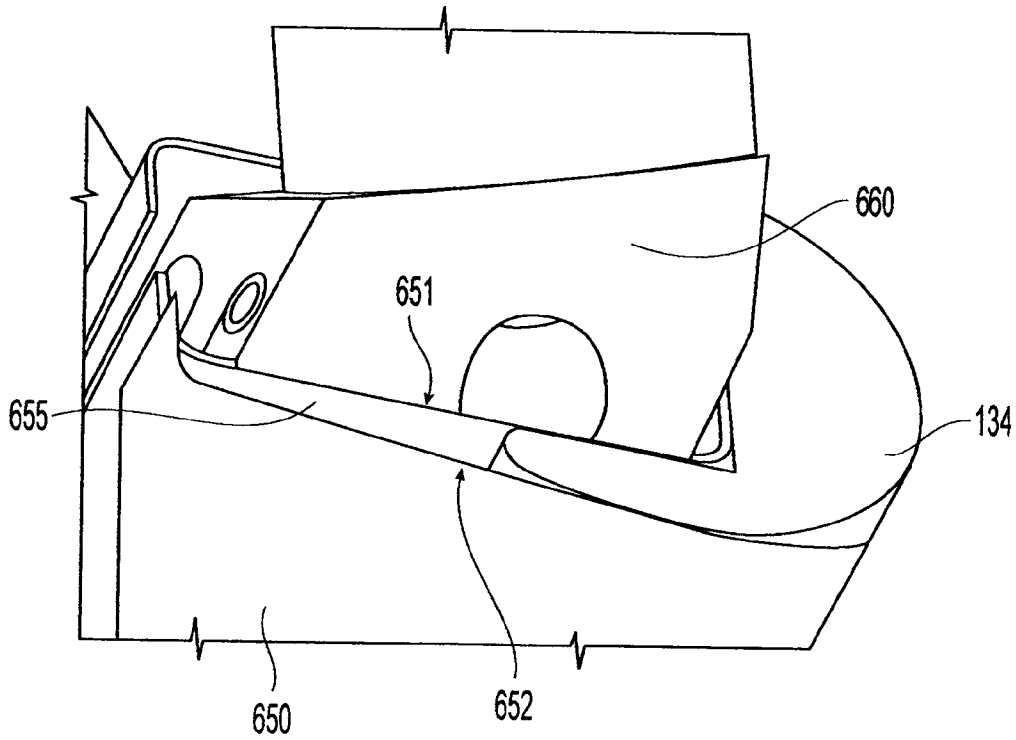

Fig. 25

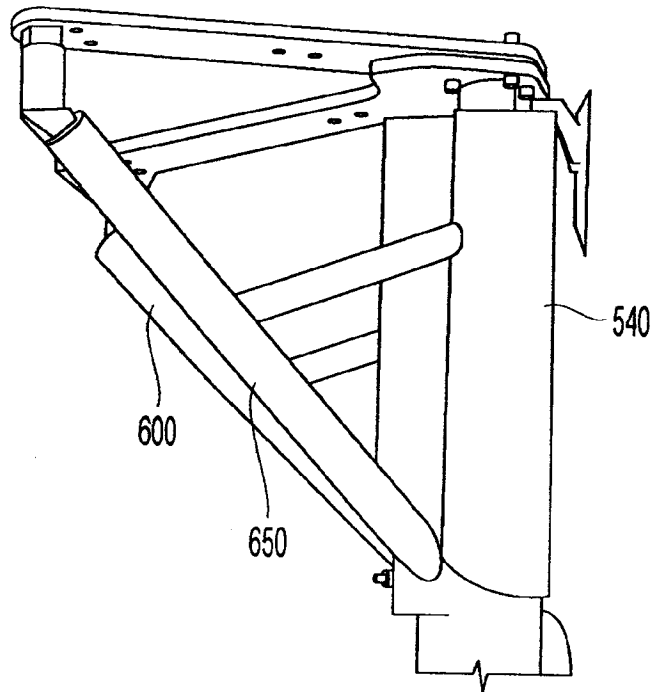

Fig. 26

LANDING GEAR NOISE ATTENUATION

RELATED APPLICATIONS

The present application claims priority to U.S. Provisional Patent Application No. 60/557,236, filed Mar. 29, 2004 and U.S. Provisional Patent Application No. 60/641,246, filed Jan. 4, 2005. The contents of these two provisional applications are incorporated by reference in their entirety.

STATEMENT REGARDING FEDERALLY SPONSORED RESEARCH

Some aspects of the inventions described in this patent application were made in the performance of work under NASA Contract No. NAS1-03008 and may be subject to the provisions of Section 305 of the National Aeronautics and Space Act of 1958 (42 U.S.C. 2457).

FIELD OF THE INVENTION

This invention relates to landing gear noise attenuation and more specifically to apparatus intended to mitigate airframe landing gear noise.

BACKGROUND

The interaction of airflow with an airframe's protrusions and cavities creates airframe noise. While engine noise dominates aircraft noise at takeoff, the airframe noise created by landing gear is a substantial contributor to approach noise for many aircraft. During approach, an aircraft engine is operating at less power than that during takeoff. Hence, the noise from the airframe is comparable to that of the engine noise.

The landing gear of commercial aircraft represent a complex system of wheels, axles, trucks or bogie beams, brakes, cable harnesses, torque links, braces, structure interfaces and wheel hubs. Skilled landing gear designers traditionally have emphasized the operational parameters attendant to proper deployment, operation and retraction of landing gear, and have not previously been directed to address noise attenuation as a design priority. While various noise reduction designs are known for fixed landing gear noise attenuators for deployable landing gears are less developed.

There is a need for retractable landing gear attenuation structures that successfully reduce noise emanating from the landing gear acoustic signature. The complexity of non-acoustical constraints on the design of landing gears have not permitted effective and practical noise minimization designs.

SUMMARY OF THE INVENTION

The present invention is directed to devices and systems for noise attenuation of deployable landing gear.

In one aspect, the invention is directed to deployable landing gear truck fairing which comprises: an elongated body connected to a rising front portion, the elongated body having first and second lateral edges; and first and second compliant edges affixed to corresponding first and second lateral edges.

The elongated body comprises a forward assembly and an aft assembly; the first lateral edge comprises adjacent first and second lateral edge portions on a first side of the fairing, the first lateral edge portion being associated with the forward assembly and the second lateral edge portion being associated with the aft assembly; and the second lateral edge comprises adjacent third and fourth lateral edge portions on a second side of the fairing, the third lateral edge portion being asso-

ciated with the forward assembly and the fourth lateral edge portion being associated with the aft assembly.

A first compliant edge portion may be affixed to the first lateral edge portion; a second compliant edge portion may be affixed to the second lateral edge portion; a third compliant edge portion may be affixed to the third lateral edge portion; and a fourth compliant edge portion may be affixed to the fourth lateral edge portion, such that the first and second compliant edge portions are adjacent to one another and the third and fourth compliant edge portions are adjacent to one another.

When the truck fairing is mounted on deployable landing gear of an aircraft, adjacent compliant edge portions are spaced apart from one another by a first distance when the aircraft is on the ground; and move closer to one another when the aircraft is not on the ground.

In another aspect, the invention is directed to a deployable landing gear truck fairing, comprising: a pair of adjacent fairing sections defining a forward assembly and an aft assembly suitable for mounting on a truck, each assembly having a first side and a second side; a center seal affixed to at least one of the forward and aft assemblies and positioned between the two assemblies; adjacent first and second compliant edge portions affixed to the first side of the forward and aft assemblies; and adjacent third and fourth compliant edge portions affixed to the second side of the forward and aft assemblies.

When the truck fairing is mounted on deployable landing gear of an aircraft, adjacent compliant edge portions are spaced apart from one another by a first distance when the aircraft is on the ground; and move closer to one another when the aircraft is not on the ground.

Opposing surfaces of adjacent compliant edge portions may abut one another when the aircraft is not on the ground. These opposing surfaces may be are angled.

In yet another aspect, the present invention is directed to a landing gear noise attenuator for deployable landing gear having a truck beam and tires. The attenuator comprises a tray positioned under the truck beam; a rigid portion on the tray; and at least one compliant edge on the tray, the compliant edge being proximate to the tires and capable of yielding elastically when a force is applied to the edge.

In yet another aspect, the present invention is directed to an inflatable, deployable landing gear noise attenuator adjustable between a first, deflated position when the deployable landing gear is retracted, and a second, inflated position when the deployable landing gear is deployed. The inflatable noise attenuator may take on one of several forms. For example, the noise attenuator may be an inflatable door panel fairing suitable for attaching to a portion of a door panel. The noise attenuator may be an inflatable main strut fairing suitable for mounting on a main strut of a landing gear assembly. The inflatable door panel may be attached to the inflatable main strut fairing. The noise attenuator may be an inflatable truck fairing suitable for mounting on a truck of a landing gear assembly. The noise attenuator may be an inflatable drag strut fairing suitable for mounting on a drag strut of a landing gear assembly. The noise attenuator may be an inflatable torque link fairing suitable for surrounding a torque link of a landing gear assembly. A torque link panel may be associated with the torque link panel. The inflatable torque link may be attached to the inflatable truck fairing.

In yet another aspect, the present invention is directed to a system for inflating and deflating inflatable deployable landing gear noise attenuators. Such a system comprises a reservoir configured to store pressurized air of sufficient pressure to inflate one or more of said noise attenuators, said reservoir

being connected to a pressure regulator; vacuum means configured to remove air from said noise attenuators; and a manifold configured to selectively connect said reservoir and said vacuum means to said noise attenuators.

A compressor or engine air bleed may be used to charge the reservoir. The vacuum means may be a dedicated vacuum pump or an engine vacuum device.

In yet another aspect, the present invention is directed to apparatus for passive noise reduction of landing gear. An exemplary apparatus is a brake cover fairing partially covering a piston and piston housing of a front brake of a landing gear assembly and having a less than full circumferential design. Another exemplary apparatus is a fairing insert suitable for inserting into a pocket of a brace belonging to a landing gear assembly, the fairing insert having a bulbous front section and a tapered rear section to help minimize noise generation. Yet another exemplary apparatus is a pocket filler fairing secured in a pocket of a brace belonging to a landing gear assembly by means of a non-removable fastener. Yet another exemplary apparatus is a door/shock strut interface noise reduction fairing comprising a multi-piece fairing that attaches to a shock strut via an existing hydraulic and/or electrical bracket along a length of said shock strut. Yet another exemplary apparatus is a tear-drop shaped shock strut fairing extending from an interface gap around a front of the shock and covering electrical and hydraulic lines that extend along the front of the shock, the tear-drop shaped fairing being configured to allow the shock strut to function both in a deployed pre-touchdown position, and also in compressed position after touchdown.

These and other aspects of the present invention will become apparent to those skilled in the art after a reading of the following description of the preferred embodiments, when considered in conjunction with the drawings. It should be understood that both the foregoing general description and the following detailed description are exemplary and explanatory only and are not restrictive of the invention as claimed.

BRIEF DESCRIPTION OF THE DRAWINGS

FIGS. 1 through 3 are views of a conventional prior art landing gear assembly.

FIG. 4 is a landing gear containing fairings in accordance with an embodiment of the present invention.

FIG. 5A is a partial isometric view of landing gear containing fairings in accordance with an embodiment of the present invention.

FIG. 5B is a partial underside view of a landing gear containing fairings in accordance with an embodiment of the present invention.

FIGS. 6A through 6D are views of a truck and fairing in accordance with an embodiment of the present invention.

FIGS. 7A through 7E are views of a truck fairings of the present invention.

FIG. 8 is an exploded view of a compliant edge of a truck fairing of the present invention.

FIG. 8A is a view of another embodiment of a truck fairing with a compliant edge in accordance with the present invention.

FIG. 8B is a view of a close-up of a center seal of truck fairing of FIG. 8A.

FIG. 8C shows the separation between the forward and aft assemblies when the aircraft is on the ground, for the truck fairing of FIG. 8A.

FIG. 8D shows the forward and aft assemblies in abutment via the center seal, when the aircraft is in air, for the truck fairing of FIG. 8A.

FIG. 8E shows a cross-section of either the forward or aft assembly of the truck fairing of FIG. 8A.

FIG. 8F shows a close-up of one side of FIG. 8E.

FIG. 8G shows a cross-section of a compliant edge in accordance with one embodiment of the present invention.

FIG. 8H shows a cross-section of a compliant edge in accordance with another embodiment of the present invention.

FIG. 8I shows a side view of the separation of a compliant edge when an aircraft is on the ground.

FIG. 8J shows a side view of a compliant edge when an aircraft is in the air.

FIGS. 9A through 9C are views of a truck fairing of the present invention.

FIG. 10 is a brake fairing of the present invention.

FIG. 11 shows structural fairings of the present invention.

FIGS. 12A and 12B show structural fairings of the present invention.

FIGS. 13A and 13B are door/shock strut interface fairings of the present invention.

FIGS. 14A-14D are door/shock strut interface fairings of the present invention.

FIG. 15 is a shock strut fairing of the present invention.

FIG. 16A is a system diagram of the components for inflatable fairings of the present invention.

FIG. 16B is a pressure reservoir and regulator of the sort used in conjunction with FIG. 16A.

FIG. 17 is a front left view showing landing gear fairings of the present invention.

FIG. 18 is an aft view showing landing gear fairings of the present invention.

FIG. 19 is a section view of an inflatable fairing and girt of the present invention.

FIG. 20 is a sectional view of an outer girt construction of the present invention.

FIG. 21 is an inflatable truck fairing of the present invention, with wheels removed for clarity.

FIG. 22 is an underside view of a truck fairing of the present invention.

FIG. 23 is an aft view of a truck fairing of the present invention.

FIG. 24 are drag strut fairings of the present invention.

FIG. 25 is a sectional view of a drag strut fairing of the present invention.

FIG. 26 is a view of fairings of the present invention.

DETAILED DESCRIPTION

Landing gear fairings are an effective approach to reduce noise. Fairings improve the aerodynamic characteristics of the landing gear system, such that the unsteadiness of the airflow is minimized. While fixed fairings have been used traditionally for non-retractable landing gear, the employment of fairings in conjunction with retractable landing gear is limited due to the confined space of the fuselage nose section and of the relatively thin wing sections.

Due to size constraints, a full enveloping fixed fairing for a landing gear is not feasible. Alternatively, significant noise attenuation is achievable by partially fairing critical components of landing gear.

FIGS. 1, 2 and 3 illustrate a conventional main landing gear 10. For ease of illustration, certain cable harnesses and hydraulic lines are not shown. Landing gear 10, shown in a deployed position, includes wheels 12, axles 14, trucks or bogie beams 18, brakes 22, cable harnesses (not shown), torque links 30, struts 32, braces 34, structure interfaces 38, wheel hubs 42 and door 46. Unless otherwise stated, the terms

“down or deployed position” mean when the landing gear is deployed, but prior to contact with a runway or other landing surface.

Selected landing gear components are suitable for adaptation, modification or redesign featuring aerodynamic components. FIG. 4 illustrates several types of fixed fairings covering or shielding selected landing gear components.

As shown in FIGS. 4, 5A and 5B, a truck fairing 210 can cover the forward end, underside, and aft end of the truck beam, respectively. The truck fairing 210 also can extend to cover the brakes 22, and certain wire harness (not shown). In another embodiment, the truck fairing 210 may extend to cover the torque links 30. FIG. 5A shows an isometric view of the fairing 210 covering the truck beam 18, axles 14, and brakes (partially) 22 on a landing gear. FIG. 5B shows a view from the underside of the landing gear.

The truck fairing 210 may be a rigid structure, or may consist of a rigid lower fairing and a smart, or retractable, upper fairing. To accomplish a smart or retractable upper truck fairing, a localized torque link fairing along with bundled, shielded or rerouted cable harnesses may be employed. Alternatively, a truck fairing, or combination of fairings, that retract or rotate after landing to allow air flow for brake cooling, access to the tow fitting, and access to the jacking pad can be employed. The movement of the smart upper fairing can be accomplished by adding a powered hydraulic or electrical system to drive the fairing.

An alternative approach would be to use the stroking of the gear to static position and kinematics of braces or links to drive the fairing. In other words, as the landing gear goes through its deployment stage on approach, the hydraulic and/or electrical systems that are used to deploy the gear to its final, fully extend position can also be used to operate/deploy a smart upper truck fairing that addresses the torque link, forward and rear cable harness noise sources. Implementation of such methods and techniques are known to those of skill in the art.

The design of truck fairing 210 can reflect several design considerations. The fairing accommodates access to the jacking pads, tow fitting, and brakes 22. The lower portion of the fairing 210 blocks a substantial portion of the underside of the truck 18, but retains room for tire clearance. The truck fairing 210 can present a location for the collection of debris, and ease of inspection (and removal of such debris) is required. The truck fairing 210 also must be shaped and configured to allow for retraction and stowing of the gear in selected aircraft associated with the landing gear 10.

FIGS. 6A, 6B, 6C and 6D illustrate layouts of the truck fairing 210. For certain types of landing gear, installation of the fairing 210 will require modification of the existing gravel shields, which can be mounted to the two junction boxes on the underside of trucks. To assemble fairing 210, the design can comprise one or more separate fairing sections. Four fairing sections 214, 216, 218, 220 are shown in FIGS. 6A, 6B, 6C and 6D. Three of these fairings 214, 216, 218 can cover the underside of the truck 18, brake rods and brakes, with a fourth section 220 secured onto the tow fitting to cover the forward truck, tow fitting, jacking pad, and front brakes. The fairing 210 can be made of any aerospace-grade metal alloy, or of a suitable composite material, sheet metal or plastic.

The truck fairing 210 can be secured to the landing gear 10 in various manners. For example, standard fasteners already used on the landing gear truck 18 could be lengthened and used to restrain the fairings to existing brackets. Alternatively, band clamps 224 or other suitable forms of securing could be used to secure the fairing 210 to the truck 18.

The truck fairing 210 can reflect several design attributes. This fairing provides foreign object and debris protection to the truck 18. The fairings, suitably designed to withstand such impacts, will decrease the overall number of maintenance and repair requirements generated from foreign objects impacting the gear. The fairing 210 can be designed for ease of maintainability. Preferably, the design minimizes the removal and maintenance of the fairing 210, or, alternatively, if removal is needed, the removal and installation procedures are simple enough to not significantly increase the task time required for routine maintenance. In another embodiment, drain holes are incorporated in the fairing to allow removal of any hydraulic fluid or other liquids that may gather in the normal course of landing gear operation and servicing. Routine inspections can be performed to ensure that any foreign objects or debris, including rocks, safety wire, etc., has not collected in the fairing. If an actively driven smart fairing is installed on the truck 18, a routine inspection of the hydraulic or electrical system used to drive the smart fairing will be necessary.

FIGS. 7A-7E, 8, 8A-8H, and 9A-9C show a compliant edge and truck fairing. As used herein, “compliant” means willing to yield, extend or displace elastically in response to a force, but capable of substantially resuming its original shape thereafter. The compliant edge in this embodiment is proximate to the tires and capable of yielding elastically when a force is applied to the edge. The compliant edge is capable of substantially recovering size and shape after deformation. The truck fairing can comprise a tray positioned under the truck beam, a rigid portion on the tray and at least one compliant edge on the tray.

More specifically, FIGS. 7A through 7E show views of a truck beam, with a fairing 1210 disposed under the truck beam. The fairing 1210 can be comprised of fairing sections 1214, 1216, 1218 that cover the underside of the truck, brake rods and brakes, with a fourth section 1220 secured proximate to the tow fitting to cover the forward truck, tow fitting, jacking pad, and front brakes.

A compliant edge 1250 can comprise nylon or other suitable type of bristles, proximate to the tires 13, brakes 22, wheel hub 42 and wheels 12. The bristles can be attached through riveting strips 1252 or other suitable connectors. Alternatively, the compliant edge 1260 can comprise soft rubber or other elastomeric polymer. The compliant edge further can be made of a material that is inert, chemically resistant and/or heat resistant.

In one embodiment, the edge is constructed of a molded plastic or thermoplastic polyolefin such as DEXFLEX® 880 made by D & S Plastics International Partnership of Grand Prairie, Tex.

FIG. 7E shows the fairing 1210 with a compliant edge 1250 in a view looking aft. In this view, some of the compliant bristles 1252 are in front of the tire, and not deflected, while other bristles 1254 are shown as being deflected as a result of the tire contacting the bristles 1254 of the compliant edge 1250.

FIG. 8 shows an exploded view looking aft of the fairing and landing gear where the fairing 1210 has a compliant edge 1260. The rigid portions (such as sections 1220, 1218, 1216 and 1214 shown in FIG. 7B) of the fairing 1210 can be made of rigid metallic or composite materials, and are mounted about the truck bogie beam 18 with a support arm 1270, and arch 1280, as shown in FIG. 8. A bias member 1290, which can be in the form of spring steel or other suitable materials, can be provided and is mounted to a rigid portion of the fairing 1210, as shown in FIG. 8. A compliant edge 1260 can then be connected to the bias member 1290 and fairing 1210. The compliant edge 1260 can be made of rubber, such as Dex-

flex® 880. In one embodiment, the compliant edge can be located a distance LE from the gear centerline **1255**. In an embodiment suited for the Boeing 777 aircraft, for example, the distance LE can be from about 12 to 17 inches, and preferably about 15 inches, and most preferably about 14.9 inches. The rigid portion can have a width of about 24 inches, or preferably about 23.8 inches.

FIG. **8A** shows another embodiment of a toboggan-type truck fairing **800**. Fairing **800** includes an elongated body **801** connected to a rising forward portion **802A** that preferably is curved. The elongated body **801** has lateral side edges **811**, **813** to which are affixed compliant edges, discussed further below.

The fairing **800** includes a rigid forward panel assembly **802** that is adjacent to the curved forward portion **802A**. The fairing **800** also includes a rigid aft panel assembly **804** which preferably has the same width as the forward assembly **802**. Thus, fairing **800** can comprise a plurality of fairing sections. The forward and aft assemblies **802**, **804** can be formed of metallic or composite materials. In the case of metallic materials, they may be formed of aluminum. In the case of metallic materials, they may be formed of aluminum. In one embodiment, the forward assembly **802** and the aft assembly **804** are unconnected to one another. They are mounted to respective forward and aft portions of a truck or bogie beam **18** and/or other parts of the landing gear, and are separated by a center seal **806**, described below. The underside of the fairing **800** preferably is flat, in contrast to truck fairing **210**.

The front assembly **802** further comprises a forward panel support assembly **810A** including a mounting bracket **810B** for mounting to the inside surface of the curved forward portion **802A**. In addition, the front assembly **802** includes a forward upper shield plate **812A** having a raised medial surface **814A**, and an aft junction box **816A** atop a portion of the raised medial surface **814A**.

The aft assembly **804** includes an aft upper shield plate **812B** having a raised medial surface **814B**, and an aft junction box **816B** atop a portion of the raised medial surface **814B**. The far aft end of the aft assembly **804** is provided with a pin **820** atop a rearwardly projecting fin **822** belonging to an upstanding support **824**.

Also, at spaced intervals along the length of the forward and aft junction boxes **816A**, **816B**, respectively, are shield supports **826** and braces **828**.

As seen in FIG. **8A**, a center seal **806** extends in a direction transverse to the elongated body **801** and along at least a portion of the width of the fairing **800** separates the forward assembly **802** from the aft assembly **804**. As seen in FIG. **8B** where the compliant edges **830a**, **830b**, **832a**, **832b** have been removed, the center seal **806** preferably is formed from a flexible, compressible elastomeric material. As shown in FIG. **8c**, the center seal **806** can comprise a generally rectangular body portion **806a** having a longitudinally extending hollow aperture **806b**, and a downwardly extending tongue portion **806c** connected to the top region of the body portion **806a** and extending in a direction parallel to a proximate sidewall of the body portion **806a**.

As seen in FIGS. **8c** and **8d**, the rear end of forward assembly **802** and the front end of the aft assembly **804** can be provided with upturned flanges **808a**, **808b**, respectively. In one embodiment, the flange **808b** is secured to the center seal **806** at the tongue portion **806c**. This is done by adhesive or by riveting, although other techniques may also be employed.

When the aircraft is on the ground (the "loaded" condition), the flanges **808A**, **808B** of the aft assembly **802** and forward assembly **804**, respectively, are separated by a first distance **D1**, which is approximately 1.2-1.6 inches. In this condition,

the center seal **806** is spaced apart from the flange **808a** so that there is no contact therebetween. On the other hand, when the aircraft is in the air, the flanges **808a**, **808b** of the aft assembly **802** and forward assembly **804**, respectively, are separated by a lesser, second distance **D2**, which is approximately 0.8-1.0 inches. In this condition, the center seal **806** abuts the flange **808B** of the forward assembly and the center seal **806** is slightly compressed. It can therefore be seen that there is a difference in separation between the forward and aft assemblies, depending on whether the aircraft is in flight, or on the ground. It is further understood while in the embodiment described above, the center seal **806** is secured to the flange **808a** of the aft assembly **804**, one may instead secure the center seal **806** to flange **808b** of the forward assembly **802**.

As also shown in FIG. **8a**, the fairing **800** is provided with four compliant edge portions **830**. A first pair of these, **830a**, **830b**, are provided on the first lateral edge **811** of the elongated body **801**, while a second pair **832a**, **832b** are provided on the second lateral edge **813**. Thus, each lateral edge **811**, **813** comprises adjacent portions the forward assembly **802** and the aft assembly **804** on one side of the elongated body portion **801**. Furthermore, each lateral edge **811**, **813** is provided with a compound compliant edge that comprises a pair of separate compliant edge portions adjacent to one another.

FIGS. **8i** and **8j** show the compliant edge in the foreground and omit the central seal, but otherwise are similar to FIGS. **8c** and **8d**. As seen in FIG. **8i**, when the aircraft is on the ground, the adjacent forward and aft compliant edges **830a**, **830b**, respectively, on the same side of the fairing **800** are spaced apart from one another, due to the increased separation experienced by the forward and aft assemblies **802**, **804**, discussed above with respect to FIG. **8c**. Preferably, the opposing ends of adjacent forward and aft compliant edges are angled at complementary angles, such as about 45 degrees, so as to form angled abutments **870a**, **870b** when in the unloaded condition.

And as seen in FIG. **8j**, when the aircraft **800** is in the air, the forward and aft assemblies **802**, **804** are closer to one another and the adjacent forward and aft compliant edges **830a**, **830a** on the same side of the fairing **800** to abut one another at abutments **870a**, **870b**. The angled cut at the abutment interface helps prevent excessive deformations at the end due to misalignment when the adjacent compliant edges meet.

As seen in the cross-sectional view of FIGS. **8e** and **8f** of either the front or aft assembly, **802**, **804**, the fairing **800** comprises lower shield plates **834a**, **834b** opposing corresponding upper shield plates **812a**, **812b**. Preferably, the upper shield plates are formed from aluminum having a thickness of about 0.1 inches, while the lower shield plates are formed from aluminum having slightly less thickness, on the order of about 0.063 inches thick. It is understood that other thicknesses of aluminum, and even other materials, may be used.

As seen in FIG. **8f**, the elongated gripping portion **838** of the compliant edge **830** is inserted between the upper shield plates **812a**, **812b** and the lower shield plates **834a**, **834b** and secured to these by fasteners **840**. A weight bearing spacer **836** is positioned inward of the gripping portion **838**, between the upper shield plates **812a**, **812b** and the lower shield plates **834a**, **834b**. The spacer **836** is located below the support **826** and thus serves as a weight-bearing element, thereby preventing the elongated gripping portion **838** of the compliant edge **830** from being crushed between the upper shield plates **812a**, **812b** and the lower shield plates **834a**, **834b**. Preferably, the spacer **836** has a thickness between about 0.2 to about 0.3 inches, and more preferably is 0.25 inches.

As seen in FIG. 8g, the projecting portion **840** of the compliant edge has a length D3, which preferably is between about 2 to about 4 inches and more preferably is about 3 inches. The compliant edge's tip portion **842** is angled slightly upwardly, relative to the remainder of the compliant edge. The length D4 of the tip portion **842** is preferably between about 0.75 and about 1.25 inches in length, and more preferably is about 1 inch. Furthermore, the tip portion **842** preferably is angled upwards between about 10° to about 30°, although amounts outside this range may also be effective.

In one embodiment, as shown in FIG. 8g, the compliant edge **830** has a two-ply polyester/fiberglass reinforced core **844** in areas away from the gripping portion **838** and a four-ply polyester/fiberglass reinforced core **846** in the gripping portion **838**, especially in those areas proximate to the fasteners **840**. Surrounding the cores **844**, **846** is an elastomeric material **848** which gives the compliant edge **830** its shape. The elastomeric material **848**, in turn, is covered with a knit cover **850** to provide a smooth surface finish. In one embodiment, the knit cover **850** is formed of Dacron®.

Preferably the core **846** comprises a polyester/fiberglass reinforced cloth. The stiffness of the compliant edge in a widthwise direction may be varied by changing the number of layers of the polyester/fiberglass reinforced cloth. To prevent excessive wear and/or damage, a 2-ply construction is preferred in areas of the compliant edge that are proximate to the tires while a 4-ply construction is preferred in areas away from the tires to provide enhanced greater stiffness.

FIG. 8h shows an alternative embodiment of a compliant edge **860** in which the tip portion **862** is not angled, the compliant edge **860** being similar in construction to compliant edge **830** seen in FIG. 8g.

Under normal operating conditions, whether on the ground or in the air, the compliant edges **830**, **850** are not intended to be deflected by brushing against the tires and/or wheels, as are bristles **1254**, discussed above with respect to FIG. 7E. Thus, no tire/wheel rub is expected with compliant edges **830**, **850**.

FIG. 9A through 9C show further views of a fairing **1210**, with the compliant edge **1250** installed. In an embodiment suited for the Boeing 777 aircraft, the fairing **1210** can be attached to the main truck beam **18** with fittings common to an electrical box **212**, which can house various cabling and wires used in the landing gear. The fairing **1210** replaces a gravel shield (not shown) on the current Boeing 777 design used to protect the electrical box. In the embodiment shown, the clearance between the fairing and the brake disks **22** is about 0.4 inches.

A truck fairing **1210** with a compliant edge **1260** in accordance with this invention allows the fairing **1210** to fit in close proximity to the landing gear tire **13**. Noise tests have demonstrated that noise reduction is a function of the distance between the fairing and edge of the tire, with fairings that minimize the gap between the fairing edge and the tire performing well. This relationship was demonstrated during wind tunnel testing of a landing gear with no fairing, a landing gear with a narrow width truck fairing, and a landing gear with a maximum width fairing. Under wind tunnel test conditions equivalent to an aircraft landing approach velocity, a flyover angle of incidence and a truck angle of 13 degrees toe up, the noise levels consistently decreased at numerous frequencies as the fairing width increased.

While test have demonstrated that a wide truck fairing is beneficial, the integrity of a fairing structure may be at risk if the fairing is too close to the tires. Aircraft tires can deflect under landing loads and ground maneuvering. Hence, even if a clearance between the tires and fairing exists when the aircraft is at rest, this clearance can be reduced to zero when

the aircraft is maneuvering. The most extreme deflections occur when an aircraft has a maximum load, such as when an aircraft is fully loaded with fuel, passengers and cargo for take-off. Under such loads, the aircraft may have to pivot about its main gear, leading to tire deflection. These deflections are increased if the main gear steering is not used. The specific design parameters for the truck fairing and compliant edge will be dependent upon the landing gear and amount of tire deflection anticipated and/or measured. The width of the fairing and associated compliant edge can be maximized, but preferably not so wide as to contact the tire or wheels during normal taxiing, take off, landing or normal ground maneuvering while the tire may be turning at high speeds. Preferably the compliant edge does not contact the tire under such conditions in order to avoid tire wear. The extreme maneuvering conditions where contact occurs with the tire and compliant edge should occur seldom and should not contribute to excessive tire wear because of the low incidence of occurrence and the low rotational speeds of the tires under such extreme conditions.

A truck fairing with a compliant edge allows the fairing to block or limit air flowing through or around the edge while at the same time being flexible enough to deflect during extreme ground maneuvering or even tire rupture. The compliant edge can be comprised of rubber or fabric stripping, fiber reinforced rubber, nylon brush, spring steel or an inflatable bladder, and other equivalent structures. Such compliant edges allow for proper functioning of a noise attenuator, while minimizing any adverse effects of tire rub. Although in the embodiments shown, the compliant edge is provided only in proximity to the tires, the compliant edge can extend the entire edge of the fairing proximate to the tires. Such an embodiment would allow for forward-aft adjustments, and possibly provide a universal fit for multiple landing gear configurations.

FIG. 10 illustrates a fixed brake cover fairing **240**. Fairing **240** streamlines the airflow over the brakes by partially covering the piston and piston housing of the front brakes. The less than full circumferential design of the fairing **240** promotes cooling to minimize the effect of the fairing on brake performance and to promote brake cooling while the aircraft is parked at the gate.

Alternatively, the fairing **240** may also incorporate smart fairing components that retract out of the way while the aircraft is on the ground to facilitate brake cooling. The design of fairing **240** may also incorporate brake cooling ducts to help decrease the time required for brake cooling.

In addition, or in the alternative, to a separate brake cover fairing **240**, a brake fairing concept can be incorporated into the lower truck fairing design **210**. As shown in FIGS. 6A and 6B, the truck fairing **210** partially covers the front brakes on the landing gear. The fourth piece **220** of the truck fairing can be secured to the tow fitting and cover the front brakes on landing approach.

FIGS. 11 through 12 illustrate fairings used to minimize noise emanating from cavities and pockets in structural members. These fairings **260**, **264** provide aerodynamic shapes to the braces **34** of the landing gear to reduce wakes generated by the braces, as well as filling in open ended pins. "Pocket filler" fairing inserts **260** can comprise low weight foam material, plastic, composite and/or metal alloy insert. The use of plastic and/or metal (such as aluminum) as opposed to a foam insert increases weight, but may be easier to attach to the structure and decreases the concern for possible foreign object and debris damage.

Fairings **260** can also comprise acetal resin inserts, such as Dupont's Delrin® resin, that fit inside the pockets of the side

and drag braces. These inserts can be restrained to the braces using existing attachment slots in the pockets. The shallow pockets on the sides of the braces do not necessarily require inserts, only the deeper pockets on the top and bottom of the braces. End caps also can be installed in hollow pins **35** about the gear. Known manufacturing practices can be utilized to manufacture the filled braces.

As shown in FIG. **12A**, fairing **264** can be designed to have a bulbous front section **265**, and a tapered rear section **263**, to help minimize noise generation.

The “pocket filler” fairings **260** can be designed to allow for ease of installation and removal. As shown by the filled brace pockets of FIG. **12B**, installation can be by traditional removable or non-removable fasteners **267**. Alternatively, in new construction, the braces can be fabricated without any pockets or cavities. When removable fasteners **267** are used, the fasteners **267** allow ease of removal of the fairings for inspections for potential cracking and corrosion of the structural members underlying the fairings, as well as inspections for moisture that may collect between the fillers and structural members.

FIGS. **13** and **14** illustrate door/shock strut interface fairings. These fairings reduce noise by eliminating the gap between the door **46** and strut **50**. In the case of fairing **280**, the gap is eliminated by making modifications to the edges of the door shape, and inserting a fairing **280** in the gap between door and the strut. As shown in FIG. **13B**, a fairing **284** can be attached to the door or shock strut.

In another embodiment, as shown in FIGS. **14A-14D**, a door/shock strut interface noise reduction fairing **288** comprises a multi-piece fairing that attaches to the shock strut via the existing hydraulic and electrical brackets along its length. The fairing extends from the door around the front of the shock strut and around the side of the gear, incorporating the shock strut concept. The door to shock strut and systems fairing can be made of aerospace grade aluminum alloys; alternatively, other materials including composite structures may be used.

FIG. **15** shows a tear drop shock strut fairing **292** that extends from the interface gap around the front of the shock, covering the electrical and hydraulic lines that run along the front of the shock strut. Such a fairing can be added as a retrofit to an existing strut, or incorporated into a design of a new landing gear strut. During operation, the shock strut fairing **292** is designed to allow the shock strut to function both in the deployed but pre-touchdown position, and also in the post-runway, compressed position. This function is permitted by the fairing internal construction allowing for sufficient clearance for compression of the shock strut when the landing gear contacts the runway or ground surface during landing. The attachment points of the fairing **292** also avoid interference with such shock strut compression.

The fairings as described herein can be installed and removed, ideally, by a single individual. Sharp edges on the fairing should be avoided in order to avoid creating safety hazards. Benefits for these fairings may include a reduction in the size and weight of the dressings that these fairing would protect. In addition to aiding noise reduction, the fairings of this invention may also act as a foreign object and debris deflector, reducing the need to increase the material size of the dressings that the fairings protect.

In another embodiment, a deployable fairing can operate to deploy upon extension of the landing gear, and then retract when the landing gear is stowed within the nose section and wing sections. A landing gear fairing, for example, can inflate when the landing gear is deployed, and deflate when the fairing is not required or desired.

As shown in FIG. **16A**, the deployment and retraction of the inflatable fairings preferably is achieved through air pressure actuation and retraction. When the landing gear is deployed, a pressure regulator **101** can be triggered to inflate the fairings **510**, **520**, **530** via a manifold **124**, as the landing gear comes into the air stream. A 400 cubic inch reservoir **114** can be charged to approximately 2,000 psig with air to inflate the fairings. A compressor **118** can charge the reservoir **114** to approximately 2,000 psig pressure. A vacuum pump **122** can deflate the fairings once the airplane is on the ground. The fairings can stay deflated during airplane takeoff. The vacuum applied to the fairings can keep the fairings from excessive movement or flapping in the air during takeoff. Alternatively, bleed air **126** from the engine can be used to charge the reservoir and an engine vacuum device **127** can apply a vacuum pressure thereby eliminating the need for a compressor and vacuum pump.

The pressure regulator **101** and reservoir **114** are shown in FIG. **16b**. In one form of operation, reservoir **114** can inflate the fairings quickly, preferably within 2 to 5 seconds from the time inflation is initiated. The reservoir **114** can be any suitable size depending upon the volume of the inflatable fairings and charged to approximately 2,000 psig pressure. In one embodiment, the reservoir can have a volume of 400 cubic inches. An air compressor **118** on board the airplane can be used to charge the reservoir **114**. The pressure regulator **101** controls the pressure of air flowing into the inflatable fairings **510**, **520**, **530**. The pressure regulator **101** actuation can be triggered by the landing gear door opening mechanism. The pressure regulator **101** can be set at a predetermined setting as appropriate for the tubing and dynamics of each installation.

A compressor **118** can charge the reservoir to approximately 2,000 psig pressure so that the pressurized air can be used to inflate the noise reduction fairings at the time of landing. To keep the weight as low as possible, the compressor preferably is a low displacement type, high pressure device that is capable of charging a reservoir to 2,000 psig while the airplane is airborne. If bleed air from the engine can be used to charge the reservoir, the need for the air compressor will be eliminated.

A vacuum pump **122** can be used to remove air out of the inflated fairings once the airplane has landed. In most cases, the fairings can stay deflated during airplane takeoff. The vacuum applied to the fairings will keep them from moving or flapping in the air during takeoff. Maintaining the fairings in their deflated condition during takeoff also will better facilitate the articulation and movement of the landing gear struts during the gear stowage operation. If a bleed air ejector valve can be used to provide vacuum, the need for a vacuum pump can be eliminated. To assure that the fairings do not exceed the maximum designed pressure, a pressure relief valve **505** can be used for each fairing. Alternatively, if the pressure can be adequately controlled by the regulator **101**, the requirement for the pressure relief valves may be eliminated. High pressure hoses **104** as depicted in FIGS. **19** and **25** can be used to direct high pressure air to the inflatable fairings, as well as to deflate the fairings when desired.

FIGS. **17** and **18** illustrate several additional embodiments for noise reduction attenuation. The deployed fairings **540**, **580**, **600**, **620**, **630**, **640**, **650** form an aerodynamic shape around various components of the landing gear when the fairings **540**, **580**, **600**, **620**, **650** are inflated in an embodiment to approximately 2.5 psig pressure. In the embodiments shown, a torque link fairing panel **630** and door panel fairing **640** are non-inflatable fabric panels that are deployed on, around, or between components of the landing gear and the inflatable fairings **540**, **580**, **600**, **620**, **650**, which serve as

deployable landing gear noise attenuators. As will be apparent to persons of ordinary skill in the art, other combinations of inflatable and non-inflatable fairings also may be used. For example, door panel fairing **640** may include an inflatable portion that at least partially fills a space between the main strut and door panel on a landing gear, and blocks or deflects noise-producing air flows that would otherwise pass between the main strut and door panel. The shape of the inflatable fairings can vary, depending upon aerodynamic or space configuration requirements.

Each inflatable fairing **540**, **580**, **600**, **620**, **650** can contain one or more inflatable chambers there within. Each inflatable chamber may require one pressure relief valve **505**. The materials forming the inflatable fairings can comprise any material that is flexible and suitable for pressurization. The exterior of the fairings should be tear-resistant and capable of withstanding the environment encountered by aircraft during takeoff and landings. To minimize damage from debris impact, at least portions of some outer surfaces of the fairings can be made from Kevlar® fibers or other suitable durable fibers and material. To minimize weight, the use of high strength fibers such as Kevlar® fibers can be limited to debris impact areas only. The fairings can be secured to the structure using a girt arrangement as discussed below.

As shown in FIGS. **17** and **18**, an embodiment of an inflatable fairing system may include a main strut fairing **540**, a forward drag strut fairing **650**, an aft drag strut fairing **600**, a torque link fairing **620**, a torque link fairing panel **630**, a door panel fairing **640**, and a truck fairing **580**.

As shown in FIGS. **17** and **26**, an inflated and deployed main strut fairing **540** surrounds a large portion of the main strut of the landing gear.

As shown in FIGS. **17**, **18**, **22**, and **24**, an inflated and deployed aft strut fairing **600** envelopes all or most of the aft drag strut of the landing gear.

FIGS. **17**, **22**, **24**, and **25**, show an inflated and deployed forward drag strut fairing **650** positioned around the forward drag strut of the landing gear. The inflatable fairings **540**, **600**, **650** provide the main, aft, and forward struts with enhanced aerodynamic profiles.

FIG. **19** shows a cross-section of one embodiment of an inflatable fairing **100** according to the invention. In this embodiment, the fairing **100** includes an inner girt **120** and an outer girt **130**. The inner and outer girts **120**, **130** are joined together on either side **106**, **108** of a separation **105** such as by stitching and/or adhesives. The separation **105** in the girts **120**, **130** permits the fairing **100** to be wrapped around a structural member of a landing gear such as a strut. Laces **110** may be used to connect edges **106**, **108** and to tighten and securely retain the inner girt **120** on the enveloped structural member **200**. The laces **110** may be a nylon cord, for example. Grommets may be provided along adjacent edges **106**, **108** for receiving the laces **110**. Other tightening and retaining means also may be used such as straps, buckles, or the like. An inflation tube **134** is disposed between the inner girt **120** and outer girt **130** on at least one side of the structural member **200**. Preferably the inflation tube is positioned opposite the laces **110**. One or more hoses **104** is used to supply and extract air from the inflation tube **134**. When the inflation tube **134** is inflated between the inner girt **120** and outer girt **130**, the outer girt **130** takes on an enhanced aerodynamic profile like that shown in FIG. **19**. More than one inflation tube **134** can be used between the inner and outer girts **120**, **130** to provide the fairing **100** with a desired shape when inflated. The inner girt **120** secures the inflatable fairing to the structure **200**, while the outer girt **130** is used to provide the shape of the fairing.

Inner girt **120** can be made from various pliable materials including, for example, a woven nylon fabric coated with polyurethane. Such materials presently are used to construct inflatable evacuation slides for commercial aircraft, for example. Outer girt **130** may be made from a combination of typical girt material and a highly durable material, such as Kevlar® fiber, to protect the inflatable fairing from debris during landing. FIG. **20** shows the construction of one embodiment of the outer girt **130**, comprising an outer debris-resistant layer **136**, a girt material layer **138**, and the inflation tube **134**. Preferably, the outer debris-resistant layer **136** and girt material layer **138** are stitched and/or bonded to one another. The girt material **138** and inflation tube **134** may be bonded to one another such as by a suitable adhesive.

Returning to FIG. **17**, an inflatable main strut fairing **540** is shown in its deployed position. The main strut fairing substantially envelopes the main strut of the landing gear, providing an aerodynamic profile to attenuate noise during landing. The main strut fairing **540** covers an outer cylinder (not shown) of a conventional landing gear. During touchdown, as the inner cylinder (not shown) of the landing gear moves within the outer cylinder, the main strut fairing **540** can move relative to other components on the landing gear.

During operation, the main strut inflatable fairing **540** is designed to allow the shock strut to function both in the deployed but pre-touchdown position, and also in the post-runway, compressed position. This function is permitted by the inflatable fairing internal being configured, dimensioned and mounted so as to allow sufficient clearance for compression of the shock strut when the landing gear contacts the runway or ground surface during landing. The attachment points of the fairing **540** also avoid interference with such shock strut compression.

An inflatable truck fairing **580** also is shown in FIG. **17**, as well as in FIGS. **21**, **22** and **23**. The inflatable truck fairing **580** can wrap substantially around a conventional truck structure like that depicted in FIGS. **5A** & **5B**. The top portion **582** of the truck fairing **580** can be secured by wrapping inner and outer girts around the truck. The bottom portion **586** of the truck fairing **580** can be secured by wrapping the inner and outer girts around an existing rock guard (not shown) under the truck. To keep the truck fairing **580** within the confines of the wheels of the landing gear, the inflatable fairing near the wheels can have specially shaped inner panels **585** like those depicted in FIG. **23**. As described above, an inner girt is used primarily to secure the inflatable fairing to the truck and an outer girt primarily provides its shape. As shown in FIG. **23**, the truck fairing **580**, when inflated, is configured and dimensioned to essentially stay within the boundaries of the wheels without touching them.

FIGS. **24**, **25** and **26** illustrate the forward and aft drag strut fairings **600**, **650**. The fairings are secured to the forward and aft drag struts of the landing gear in the manner described above. As can be seen in FIG. **25**, an inner girt **651** can be used to secure the inflatable fairing **650** to the strut **660** and an outer girt **652** can be used to provide the shape to the fairing. The construction of the outer girt **652** preferably is the same as that of the outer girt **130** shown in FIGS. **19** and **20**. The inner girt **651** can be secured to the strut **660** using conventional methods such as a cord to lace together the separation **655** in the inner and outer girts **651**, **652**.

As shown in FIGS. **17**, **22** and **24**, a door panel fairing **640** extends between a forward edge **641** of the landing gear door panel and a side or edge **643** of the main strut fairing **540**. The door panel fairing **640** can be attached to the door panel edge **641** and the main strut fairing **540** by any suitable connector or adhesive. For example, the door panel fairing **640** can be

15

attached to the door edge **641** with mechanical fasteners such as rivets (not shown), and can be attached to the main strut fairing **540** by stitching, adhesives, hook and loop fasteners, or the like. Girt fabric panels **640** can be bonded on the leading and trailing edges **641** of the landing gear door to provide a smooth transition from the door edge to the main strut inflatable fairing. The down stream edge of the panel is attached to the main strut fairing **540** using conventional means, such as by bonding, Velcro® hook and loop fasteners, etc. When the main strut fairing **540** is inflated, the door panel(s) **640** will form an aerodynamic shape to reduce noise. In certain applications where the tension in the panel(s) **640** is not sufficient to take the air loads, the panel(s) **640** may be replaced with an inflatable door panel (not shown) that is constructed like the inflatable fairings described above, and is capable of withstanding the air loads.

FIG. **18** depicts an inflatable torque link fairing **620**. The inflatable torque link fairing **620** surrounds the torque link of a landing gear and provides this portion of the landing gear with a smooth, aerodynamic shape. The torque link fairing **620** may be attached to a top surface **582** of a truck fairing **580** that underlies the torque link fairing **620**. The torque link fairing **620** is designed to cover the torque link without impairing the normal movement of the torque link when the airplane lands. As shown in FIG. **17**, and as further shown in FIGS. **18**, **21**, **23** and **24**, a torque link fairing panel **630** is configured to wrap around a lower forward portion of the main strut of the landing gear and to extend afterward over each side of the inflated torque link fairing **620**. The torque link fairing panel **630** may be attached to the sides of the torque link fairing **620** by any suitable fastener or fasteners, such as hook and loop fasteners. The torque link fairing panel **630** is constructed of a suitable fabric that can be collapsed or compressed to permit relative vertical motion between the truck and strut of the landing gear.

While preferred embodiments of the present invention have been described above, it is to be understood that any and all equivalent realizations of the present invention are included within the scope and spirit thereof. Thus, the embodiments depicted are presented by way of example only and are not intended as limitations upon the present invention. While particular embodiments of the invention have been described and shown, it will be understood by those of ordinary skill in this art that the present invention is not limited thereto since many modifications can be made. Therefore, it is contemplated that any and all such embodiments are included in the present invention as may fall within the literal or equivalent scope of the appended claims.

We claim:

1. A deployable landing gear truck fairing for a deployable landing gear truck having aft, underside, and forward portions, comprising:

an elongated body connected to a rising front portion, the elongated body and rising front portion capable of partially covering at least the underside and forward portions of the deployable landing gear truck, the elongated body having first and second lateral edges; and first and second compliant edges affixed to the corresponding first and second lateral edges.

2. The deployable landing gear truck fairing according to claim **1**, wherein the elongated body comprises:

a forward assembly and an aft assembly; and
a center seal extending transverse to a direction of the elongated body and positioned between the forward and aft assemblies.

16

3. The deployable landing gear truck fairing according to claim **2**, wherein the rising front portion is part of the forward assembly.

4. The deployable landing gear truck fairing according to claim **2**, wherein forward and aft assemblies are separable from one another.

5. The deployable landing gear truck fairing according to claim **2**, wherein the center seal is affixed to only one of the forward and aft assemblies.

6. The deployable landing gear truck fairing according to claim **2**, wherein, when the truck fairing is mounted on deployable landing gear of an aircraft, the forward and aft assemblies move toward one another when the aircraft takes off, thereby compressing the center seal.

7. The deployable landing gear truck fairing according to claim **2**, wherein at least one of the forward assembly and the aft assembly comprises an upper shield plate spaced apart from a lower shield plate.

8. The deployable landing gear truck fairing according to claim **7**, further comprising a weight bearing spacer between the upper and lower shield plates.

9. The deployable landing gear truck fairing according to claim **8**, wherein the weight bearing spacer is positioned beneath a support mounted on an upper side of the fairing.

10. The deployable landing gear truck fairing according to claim **7**, wherein a first portion of the compliant edge occupies a region between the upper and lower shield plates, and a second portion of the compliant edge projects laterally outward from said region between the upper and lower shield plates.

11. The deployable landing gear truck fairing according to claim **8**, further comprising a weight bearing spacer between the upper and lower shield plates, wherein the first portion of the compliant edge is laterally outward of the weight bearing spacer.

12. The deployable landing gear truck fairing according to claim **1**, wherein the compliant edge comprises one from the group consisting of rubber or fabric stripping, fiber reinforced rubber, nylon brush, spring steel or an inflatable bladder.

13. The deployable landing gear truck fairing according to claim **1**, wherein the compliant edge comprises a soft rubber or an elastomeric material.

14. The deployable landing gear truck fairing according to claim **1**, wherein:

the elongated body comprises a forward assembly and an aft assembly;

the first lateral edge comprises adjacent first and second lateral edge portions on a first side of the fairing, the first lateral edge portion being associated with the forward assembly and the second lateral edge portion being associated with the aft assembly; and

the second lateral edge comprises adjacent third and fourth lateral edge portions on a second side of the fairing, the third lateral edge portion being associated with the forward assembly and the fourth lateral edge portion being associated with the aft assembly.

15. The deployable landing gear truck fairing according to claim **14**, further comprising:

a first compliant edge portion affixed to the first lateral edge portion;

a second compliant edge portion affixed to the second lateral edge portion;

a third compliant edge portion affixed to the third lateral edge portion; and

a fourth compliant edge portion affixed to the fourth lateral edge portion,

17

such that the first and second compliant edge portions are adjacent to one another and the third and fourth compliant edge portions are adjacent to one another.

16. The deployable landing gear truck fairing according to claim 15, wherein, when the truck fairing is mounted on deployable landing gear of an aircraft, adjacent compliant edge portions are:

spaced apart from one another by a first distance when the aircraft is on the ground; and
 move closer to one another when the aircraft is not on the ground.

17. The deployable landing gear truck fairing according to claim 16, wherein opposing surfaces of adjacent compliant edge portions abut one another when the aircraft is not on the ground.

18. The deployable landing gear truck fairing according to claim 16, wherein opposing surfaces of adjacent compliant edge portions are angled.

19. A deployable landing gear truck fairing, comprising:
 a pair of adjacent fairing sections defining a forward assembly and an aft assembly suitable for mounting on a truck, each assembly having a first side and a second side;

a center seal affixed to at least one of the forward and aft assemblies and positioned between the two assemblies; adjacent first and second compliant edge portions affixed to the first side of the forward and aft assemblies; and adjacent third and fourth compliant edge portions affixed to the second side of the forward and aft assemblies.

20. The deployable landing gear truck fairing according to claim 19, wherein, when the truck fairing is mounted on deployable landing gear of an aircraft, adjacent compliant edge portions are:

spaced apart from one another by a first distance when the aircraft is on the ground; and
 move closer to one another when the aircraft is not on the ground.

21. The deployable landing gear truck fairing according to claim 20, wherein opposing surfaces of adjacent compliant edge portions abut one another when the aircraft is not on the ground.

22. The deployable landing gear truck fairing according to claim 21, wherein opposing surfaces of adjacent compliant edge portions are angled.

23. The deployable landing gear truck fairing according to claim 19, further comprising a brake cover fairing.

24. A deployable landing gear truck fairing for a deployable landing gear of an aircraft, comprising:

an elongated body connected to a rising front portion, the elongated body having a forward assembly and an aft assembly, a center seal extending transverse to a direction of the elongated body and positioned between the forward and aft assemblies, and first and second lateral edges; and

first and second compliant edges affixed to corresponding fast and second lateral edges;

wherein, when the truck fairing is mounted on the deployable landing gear of an aircraft, the forward and aft

18

assemblies move toward one another when the aircraft takes off, thereby compressing the center seal.

25. The deployable landing gear truck fairing according to claim 24, wherein the rising front portion is part of the forward assembly.

26. The deployable landing gear truck fairing according to claim 24, wherein forward and aft assemblies are separable from one another.

27. The deployable landing gear truck fairing according to claim 24, wherein the center seal is affixed to only one of the forward and aft assemblies.

28. A deployable landing gear truck fairing for a deployable landing gear of an aircraft, comprising:

an elongated body connected to a rising front portion, the elongated body having a forward assembly, an aft assembly, and first and second lateral edges;

the first lateral edge comprises adjacent first and second lateral edge portions on a first side of the fairing, the first lateral edge portion being associated with the forward assembly and the second lateral edge portion being associated with the aft assembly; and

the second lateral edge comprises adjacent third and fourth lateral edge portions on a second side of the fairing, the third lateral edge portion being associated with the forward assembly and the fourth lateral edge portion being associated with the aft assembly; and

first and second compliant edges affixed corresponding first and second lateral edges.

29. The deployable landing gear truck fairing according to claim 28, further comprising:

a first compliant edge portion affixed to the first lateral edge portion;

a second compliant edge portion affixed to the second lateral edge portion;

a third compliant edge portion affixed to the third lateral edge portion; and

a fourth compliant edge portion affixed to the fourth lateral edge portion,

such that the first and second compliant edge portions are adjacent to one another and the third and fourth compliant edge portions are adjacent to one another.

30. The deployable landing gear truck fairing according to claim 29, wherein, when the truck fairing is mounted on the deployable landing gear of an aircraft, adjacent compliant edge portions are:

spaced apart from one another by a first distance when the aircraft is on the ground; and
 move closer to one another when the aircraft is not on the ground.

31. The deployable landing gear truck fairing according to claim 30, wherein opposing surfaces of adjacent compliant edge portions abut one another when the aircraft is not on the ground.

32. The deployable landing gear truck fairing according to claim 31, wherein opposing surfaces of adjacent compliant edge portions are angled.