

LANTHANUM: INHIBITION OF ACTH-STIMULATED CYCLIC AMP AND CORTICOSTERONE SYNTHESIS IN ISOLATED RAT ADRENOCORTICAL CELLS

AJAI HAKSAR,† DAVID V. MAUDSLEY, FERNAND G. PÉRON,
and E. BEDIGIAN

From the Worcester Foundation for Experimental Biology,
Shrewsbury, Massachusetts 01545

ABSTRACT

Lanthanum (La^{+++}) is a well-known Ca^{++} antagonist in a number of biological systems. It was used in the present study to examine the role of Ca^{++} in the regulation of adenylyl cyclase of the adrenal cortex by ACTH. In micromolar concentrations, La^{+++} inhibited both cyclic AMP and corticosterone response of isolated adrenal cortex cells to ACTH. However, a number of intracellular processes were not affected by La^{+++} . These include the stimulation of steroidogenesis by dibutyryl cyclic AMP, conversion of several steroid precursors into corticosterone, and stimulation of the latter by glucose. Thus, inhibition of steroidogenesis by La^{+++} appears to be solely due to an inhibition of ACTH-stimulated cyclic AMP formation. Electron microscope examination showed that La^{+++} was localized on plasma membrane of the cells and did not appear to penetrate beyond this region. Since La^{+++} is believed to replace Ca^{++} at superficial binding sites on the cell membrane, it is proposed that Ca^{++} at these sites plays an important role in the regulation of adenylyl cyclase by ACTH. Similarities in the role of Ca^{++} in "excitation-contraction" coupling and in the ACTH-adenylyl cyclase system raise the possibility that a contractile protein may be involved in the regulation of adenylyl cyclase by those hormones which are known to require Ca^{++} in the process.

Studies on the cellular pharmacology of lanthanum (La^{+++}) have shown that this ion is a specific antagonist of Ca^{++} in a number of biological systems. Almost all of the effects of La^{+++} on Ca^{++} -dependent movements or reactions in intact cells have been explained by postulating that La^{+++} can replace Ca^{++} at well-defined sites on the outer cell membrane (16, 23, 29, 58). Because of this specificity in the site of its action, La^{+++} appears to provide a precise approach for the elucidation of Ca^{++} -dependent processes. Besides

the well-documented effects on the Ca^{++} -dependent "excitation-contraction" coupling in the muscle, reviewed recently by Weiss (57), La^{+++} has also been reported to affect "stimulus-secretion" coupling in a number of systems that are believed to require Ca^{++} as the coupling agent. These include catecholamine release from the adrenal medulla (8), histamine release from mast cells (14), and oxytocin-induced milk ejection from the mammary gland (30).

The requirement of Ca^{++} for the steroidogenic effect of ACTH as well as that of cyclic AMP has been known for many years (5, 6, 41). More

† Deceased 8 August 1975.

recently it has become evident that the stimulation of cyclic AMP formation by ACTH in the adrenal cortex is also dependent on Ca^{++} (2, 19, 26, 28, 31, 49). Although the exact role of Ca^{++} in this process is not well understood, it has been suggested that this ion is required for some step between the binding of ACTH to the receptor and the activation of adenylyl cyclase (21, 28, 31, 32, 49). Thus, Ca^{++} appears to be required in the coupling of a "stimulus" with enzyme activation, ACTH-receptor interaction on the plasma membrane providing the stimulus and the membrane-bound adenylyl cyclase being the enzyme activated. Therefore, the role of Ca^{++} in this system may be similar to that in the "excitation-contraction" coupling in the muscle and the "stimulus-secretion" coupling in the several other systems. Because of this similarity and because of a lack of information on the precise location of Ca^{++} involved in ACTH stimulation of adenylyl cyclase, studies were undertaken to investigate the effects of La^{+++} on cyclic AMP and corticosterone formation in isolated adrenal cortex cells. In addition, ultrastructural localization of La^{+++} in adrenal cells was examined by electron microscopy.

MATERIALS AND METHODS

Materials

Trypsin (TRSF-IGA 150 U/mg) and lima bean trypsin inhibitor were obtained from Worthington Biochemical Corp., Freehold, N. J., collagenase (Serva, 387 Mandl U/mg) and lanthanum chloride (LaCl_3) from Gallard-Schlesinger Chemical Mfg. Corp., Carle Place, N. Y., Pentex bovine serum albumin (fraction V, fatty acid poor) from Miles Laboratories, Inc., Elkhart, Ind., cyclic AMP and dibutyryl cyclic AMP from Sigma Chemical Co., St. Louis, Mo., *N*-2-hydroxyethylpiperazine-*N'*-2-ethanesulfonic acid (HEPES) from Calbiochem, San Diego, Calif., and cyclic [^3H]AMP (sp act 27.1 Ci/mmol) from New England Nuclear, Boston, Mass. Purified αS -ACTH was obtained from Dr. C. H. Li, University of California, San Francisco, Calif. All other chemicals used were of reagent grade.

Methods

CELL SUSPENSIONS: Suspensions of isolated rat adrenal cells were prepared by collagenase-trypsin treatment of adrenal sections in Krebs-Ringer bicarbonate buffer, pH 7.4, by the method described previously (17, 20).

INCUBATION MEDIUM: The buffer medium for cell incubations (HEPES buffer) contained 136 mM NaCl, 13 mM KCl, 1.18 mM MgCl_2 , 1.0 mM CaCl_2 , 11 mM glucose, and 3.0 mM HEPES. The pH of the medium

was adjusted to 6.9–7.0 with dilute NaOH. It should be noted that bicarbonate, phosphate, and sulfate ions must be avoided in the medium because their lanthanum salts are extremely insoluble.

CELL INCUBATIONS: The cells were suspended in the HEPES buffer containing 0.5% BSA and 0.1% trypsin inhibitor and incubated for 30 min at 37°C. After centrifugation at 100 *g* for 20 min at 4°C and removal of the supernate, cell pellets were suspended for final incubation in an appropriate volume of HEPES buffer to give a concentration of $1.0\text{--}2.0 \times 10^6$ cells/ml. Incubations were carried out in duplicate or triplicate in a Dubnoff metabolic shaker at 37°C. Each incubation vessel contained 1 ml of the cell suspension, test substances dissolved in HEPES buffer (pH adjusted to 6.9–7.0), and an appropriate volume of buffer to make the final volume 1.5 ml.

MEASUREMENT OF CYCLIC AMP: Extraction and quantitative measurement of cyclic AMP were carried out according to previously published methods (1, 10, 18). Cyclic AMP experiments were performed in triplicate and three measurements were made on each replicate. Each value reported in this paper thus represents the mean of nine observations. Standard deviations were always less than 10% of the respective means.

MEASUREMENT OF CORTICOSTERONE: Corticosterone was measured in the dichloromethane extract of the cell suspensions by the sulfuric acid fluorescence method (52). Corticosterone experiments were carried out in duplicate and the average values are reported. The duplicate determinations were consistently within $\pm 5\%$ of the respective means.

In general, cyclic AMP and corticosterone experiments were done separately because of the well-known differences in the ACTH dose response curves for the two parameters (3, 34). Cyclic AMP and corticosterone values in zero time or unincubated controls in different experiments were < 2 pmol and < 0.2 nmol/ 10^6 cells, respectively. Cells incubated in the absence of stimulating agents (ACTH, cyclic AMP, or dibutyryl cyclic AMP) or steroid precursors showed negligible corticosterone synthesis, always less than 0.05 nmol/ 10^6 cells/2 h. Similarly, the basal cyclic AMP production was also negligible, i.e., the values were not significantly different from the unincubated controls. All values reported in this paper are net values obtained after subtraction of the respective zero-time controls.

PREPARATION OF TISSUE FOR ELECTRON MICROSCOPY: Cells were incubated in HEPES buffer for 30 min at 37°C with or without 1 mM La^{+++} and then centrifuged at 4°C for 20 min at 2,000 rpm. The pellets thus obtained were immediately fixed in a 2% solution of glutaraldehyde in HEPES buffer, pH 7.0, for 90 min at 0°C. After four successive washes in HEPES buffer, the pellets were postfixed in 1% OsO_4 in 0.1 M phosphate buffer, pH 7.2, for 60 min at 0°C. The samples were then washed four times with water and dehydrated through a graded series of aqueous ethanol solutions. Finally, they

were embedded in Spurr's low viscosity embedding medium obtained from Ladd Research Industries, Burlington, Vt. Ultrathin sections were cut on a Sorvall MT2-B ultramicrotome (Du Pont Instruments, Sorvall Operations, Newtown, Conn.) and viewed unstained in a Zeiss EM95-2 electron microscope.

RESULTS

Fig. 1 shows the ACTH log dose response curves for corticosterone production at different concentrations of La^{+++} . As little as $3.3 \mu\text{M}$ La^{+++} caused an inhibition of corticosterone production in response to ACTH and there was a substantial increase in the concentration of ACTH required to produce a half-maximum amount of corticosterone. With increasing concentrations of La^{+++} , there was also a progressive decline in the maximum response to ACTH. In the presence of $100 \mu\text{M}$ La^{+++} , even 40 nM ACTH did not initiate the corticosterone response and 160 nM ACTH produced only about 20% of the maximum response

observed in the absence of La^{+++} . When La^{+++} is not added to the incubation medium, a significant response is observed with $0.1\text{--}0.3 \text{ nM}$ ACTH and maximum response with $5\text{--}10 \text{ nM}$.

Fig. 2 shows the effect of different La^{+++} concentrations on the ACTH log dose response curves for cyclic AMP formation. It is evident that La^{+++} inhibited cyclic AMP formation in response to all concentrations of ACTH tested. As in the case of corticosterone, there was a progressive decline in the maximum amount of cyclic AMP formed with increasing concentrations of La^{+++} .

Fig. 3 shows the effect of adding $100 \mu\text{M}$ La^{+++} during the incubation on the cyclic AMP response of ACTH. The effect of La^{+++} appears to be very rapid and cyclic AMP formation ceases almost immediately after the addition of La^{+++} .

Fig. 4 shows the effect of different La^{+++} concentrations on corticosterone formation in the presence of maximally as well as submaximally stimulating amounts of ACTH. It is clear that

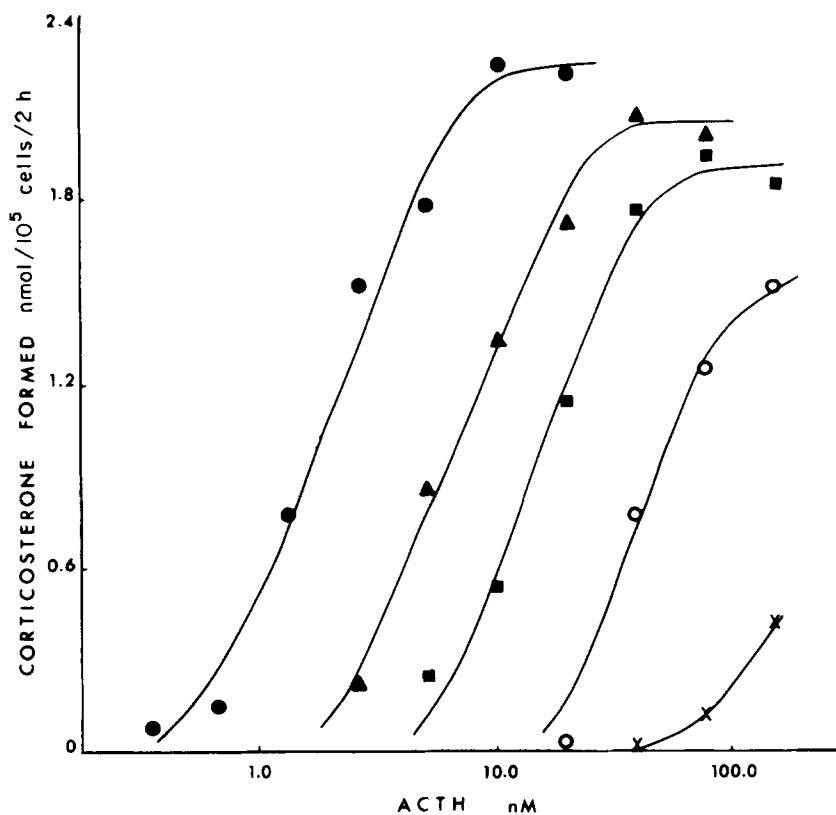

FIGURE 1 Log-dose response curves of ACTH for corticosterone formation in the presence of different concentrations of La^{+++} . Control (no La^{+++}), ●; $3.3 \mu\text{M}$ La^{+++} , ▲; $10 \mu\text{M}$ La^{+++} , ■; $33 \mu\text{M}$ La^{+++} , ○; $100 \mu\text{M}$ La^{+++} , ×.

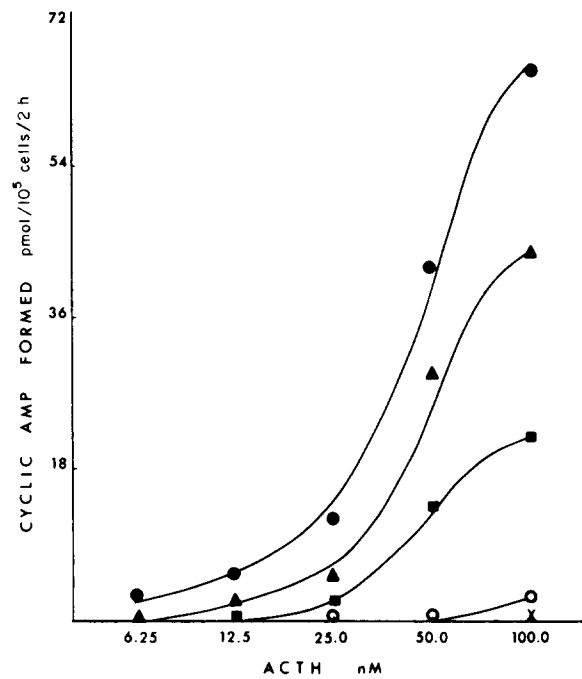

FIGURE 2 Log-dose response curves of ACTH for cyclic AMP formation in the presence of different concentrations of La^{+++} . Control (no La^{+++}), ●, 1 μM La^{+++} , ▲, 3 μM La^{+++} , ■, 10 μM La^{+++} , ○, 30 μM La^{+++} , ×.

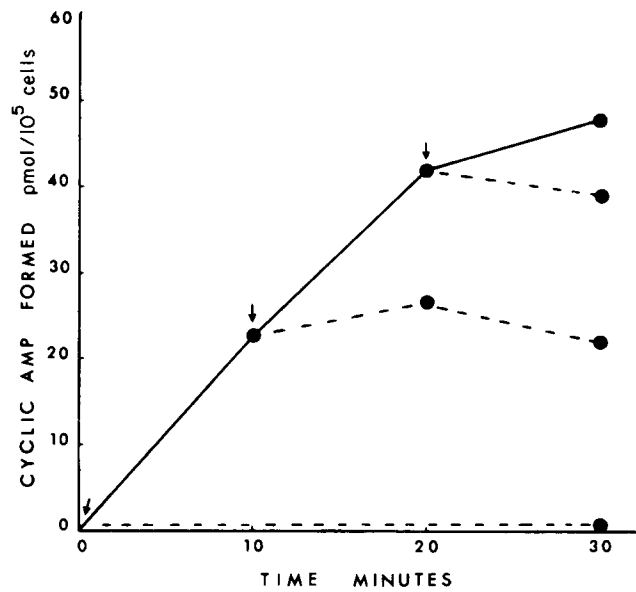

FIGURE 3 Effect of La^{+++} on cyclic AMP formation. Incubations were started with 50 nM ACTH, and 100 μM La^{+++} was added to some beakers at the times indicated by arrows. Solid line represents the progress curve for cyclic AMP formation in response to ACTH. Broken lines represent the progress curves after the addition of La^{+++} .

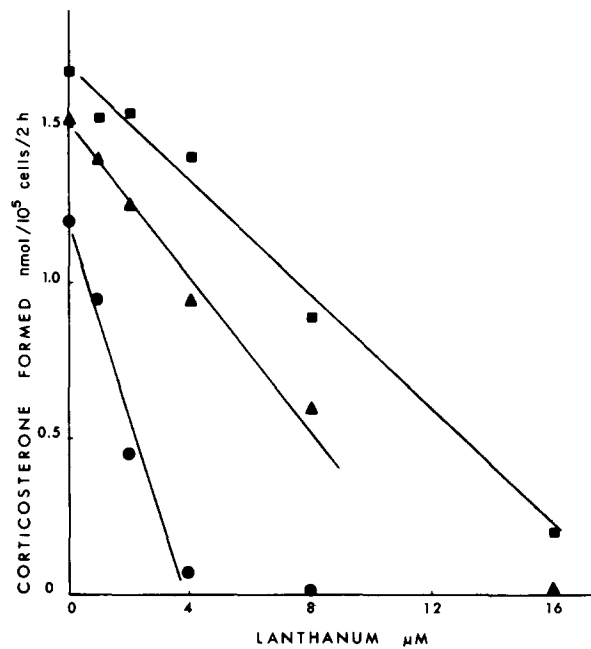

FIGURE 4 Effect of different concentrations of La^{+++} on the ACTH-stimulated corticosterone formation. Concentrations of ACTH were 1 (●), 4 (▲), and 8 (■) nM.

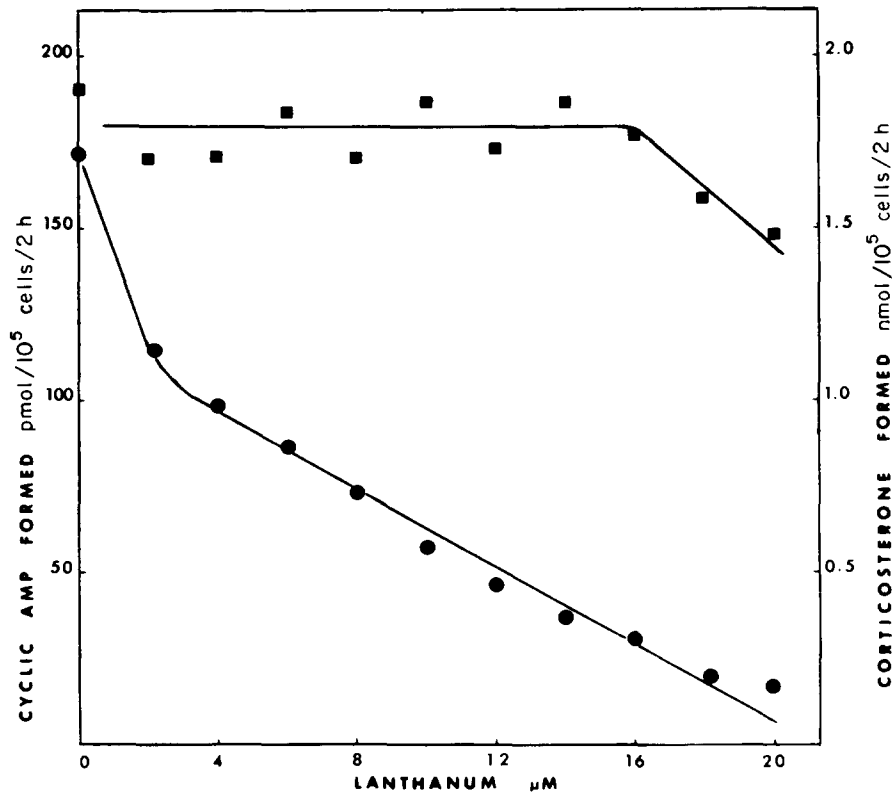

FIGURE 5 Effect of different concentrations of La^{+++} on the stimulation of cyclic AMP (●) and corticosterone (■) formation by ACTH. Concentration of the hormone was 100 nM.

TABLE I
Lack of Effect of La^{+++} on the Conversion of Steroid Substrates into Corticosterone

Additions	Corticosterone formed (nmol/10 ⁶ cells/2 h)	
	No La^{+++}	100 μM La^{+++}
None	<0.05	<0.05
11-Deoxycorticosterone	4.9	5.0
11-Deoxycorticosterone + glucose	12.8	13.4
11 β -Hydroxyprogesterone	1.6	1.6
11 β -Hydroxyprogesterone + glucose	6.3	6.2
Pregnenolone	2.4	2.1
Pregnenolone + glucose	6.9	6.2
Glucose	<0.05	<0.05

The cells were suspended in HEPES buffer without glucose. Incubations were then carried out in the absence or presence of 10 mM glucose.

The concentrations of steroid substrates were: 11-deoxycorticosterone, 60 μM ; 11 β -hydroxyprogesterone, 30 μM ; and pregnenolone, 40 μM . These are optimum concentrations as determined in the previous studies (33).¹

La^{+++} is more effective at lower ACTH concentrations. Thus, in the presence of 1, 4, and 8 nM ACTH, 50% inhibition of corticosterone synthesis was obtained with approximately 2, 6, and 9 μM La^{+++} . In other experiments carried out with supramaximally stimulating amounts of ACTH, there was further increase in the concentration of La^{+++} required to produce 50% inhibition. Similar results were obtained when the formation of cyclic AMP, instead of corticosterone, was measured in response to ACTH. Fig. 5 shows an experiment carried out with 100 nM ACTH. At this concentration of ACTH, 50% inhibition of cyclic AMP formation is obtained with about 6 μM La^{+++} .

The data reported above indicate that the inhibition of ACTH-stimulated corticosterone formation by La^{+++} is due to the effect of this ion on the stimulation of adenylyl cyclase by the hormone. Nevertheless, La^{+++} could also affect some other step(s) in the steroidogenic pathway in the cell. However, this possibility is ruled out by the present experiments. Table I shows that La^{+++} (100 μM) had no effect on the conversion of three steroid substrates into corticosterone. Glucose is known to stimulate the conversion of these substrates into corticosterone (33)¹, and again, La^{+++} had no

¹Haksar, A., M. T. Lin, and F. G. Péron. 1975. Submitted for publication.

effect on this stimulation. Further, the data in Table II show that La^{+++} in concentrations as high as 1 mM had little or no effect on the stimulation of corticosterone formation by different concentrations of dibutyryl cyclic AMP.

It has been shown previously that if incubations are carried out in the absence of Ca^{++} , there is a substantial decrease in the amount of corticosterone formed in response to dibutyryl cyclic AMP (21, 49). Table III shows that addition of La^{+++} partly prevents the decrease in corticosterone formation observed under conditions where Ca^{++} has been omitted from the incubation medium. In eight different observations with 100–500 μM dibutyryl cyclic AMP, the mean (\pm SE) corticosterone formation in Ca^{++} -free medium was 73.3%

TABLE II
Lack of Effect of La^{+++} on the Stimulation of Corticosterone Formation by Dibutyryl Cyclic AMP (DbcAMP)

DbcAMP	Corticosterone formed (nmol/10 ⁶ cells/2 h)		
	La^{+++} , 0 μM	La^{+++} , 100 μM	La^{+++} , 1,000 μM
μM			
0	<0.05	<0.05	<0.05
25	0.9	0.7	0.9
50	1.9	1.6	1.7
100	2.2	2.1	2.0
500	2.5	2.6	2.5

TABLE III
Effect of La^{+++} on Dibutyryl Cyclic AMP (DbcAMP) Stimulation of Corticosterone Synthesis in Ca^{+++} -Free Medium

DbcAMP	Corticosterone formed (nmol/10 ⁶ cells/2 h)			
	No Ca^{++}	100 μM La^{+++}	1 mM La^{+++}	1 mM Ca^{++}
μM				
0	<0.05	<0.05	<0.05	<0.05
25	0.3	0.6	0.7	0.9
50	0.7	1.1	1.2	1.5
100	1.2	1.8	1.7	1.9
250	1.4	1.9	1.9	2.2
500	1.5	2.1	1.9	2.2

Cells were suspended in HEPES buffer containing 0.5% BSA and 0.1% trypsin inhibitor but no Ca^{++} . The suspensions were preincubated for 30 min at 37°C, centrifuged at 100 g for 20 min, and the cell pellets resuspended in HEPES buffer without Ca^{++} . Incubations were then carried out after the addition of substances as indicated in the Table.

($\pm 2.5\%$) of that in the presence of 1 mM Ca^{++} . When 100 μM La^{+++} was added to the Ca^{++} -free medium in these experiments, the mean corticosterone value rose to 93.3% ($\pm 1.4\%$) of that obtained in the presence of Ca^{++} . Thus, the amounts of corticosterone produced in response to dibutyryl cyclic AMP are quite similar when either Ca^{++} or La^{+++} is added to the cells suspended in a Ca^{++} -free medium.

Ultrastructural Localization of La^{+++}

Cells were incubated in HEPES buffer with or without LaCl_3 and then examined in an electron microscope as described in Materials and Methods. Fig. 6 shows the typical ultrastructural localization of lanthanum. It is clear that lanthanum is present exclusively on the cell surface and does not penetrate into the cell. Fig. 7 shows the plasma membrane and closely packed mitochondria, with typical vesicular cristae (27) in a cell that was not exposed to lanthanum.

DISCUSSION

The requirement for Ca^{++} in the steroidogenic response of the adrenal cortex to ACTH was first

described many years ago (5, 41). Since then it has been shown that in the steroidogenic action of ACTH, Ca^{++} is required for the formation of the second messenger, cyclic AMP (2, 19, 26, 28, 31, 49), as well as for reactions after the formation of this cyclic nucleotide (6, 13, 21, 24, 47, 49). A number of investigators have studied the role of Ca^{++} in the ACTH-stimulation of cyclic AMP formation, in both intact and broken cell preparations. In intact cells Ca^{++} does not appear to have an appreciable effect either on the binding of ACTH (21, 28) or on basal cyclic AMP production (19, 28). In broken cell preparations, although the Ca^{++} dependence can be demonstrated for the ACTH-stimulation of cyclic AMP formation (2, 26, 31), the cation in concentrations greater than 2 mM appears to inhibit binding of the hormone to receptor (31). In such preparations, Ca^{++} does not have an appreciable effect on the basal or fluoride-stimulated adenylyl cyclase activity (31). Such results have led several investigators to suggest that Ca^{++} is required for some step between the binding of ACTH to the receptor on the cell membrane and the activation of adenylyl cyclase (21, 28, 31, 32, 49), a step we refer to here as "coupling" of a

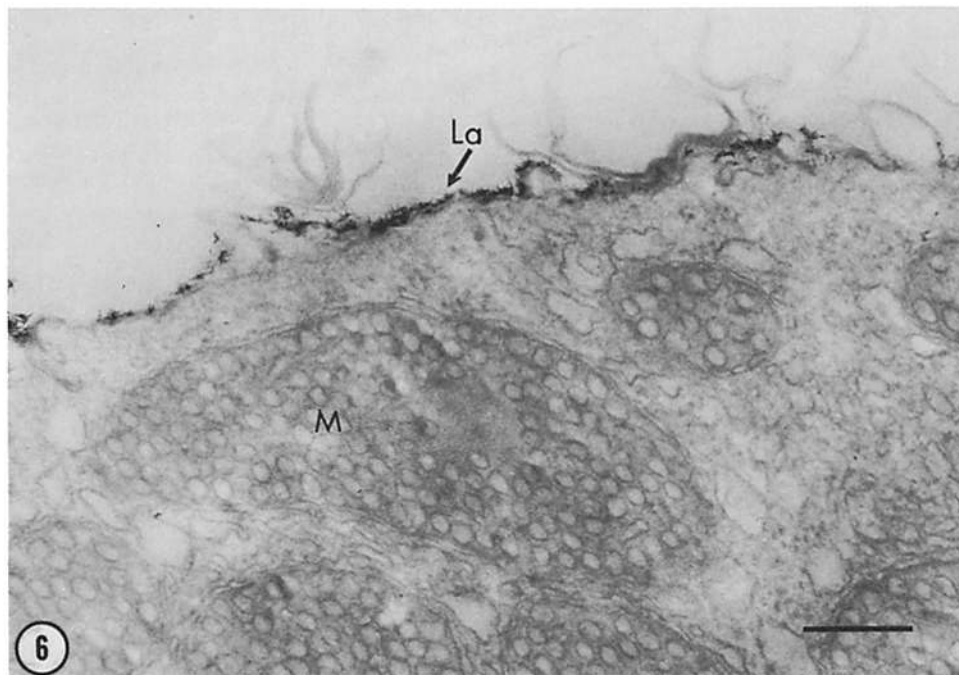

FIGURE 6 Portion of an adrenal cortex cell that was incubated for 30 min in HEPES buffer containing 1 mM LaCl_3 . Note that lanthanum (*La*) forms an electron-dense image at the cell surface but does not penetrate into the cell. This section was unstained. Mitochondria (*M*). Scale, 0.25 μm ; $\times 58,000$.

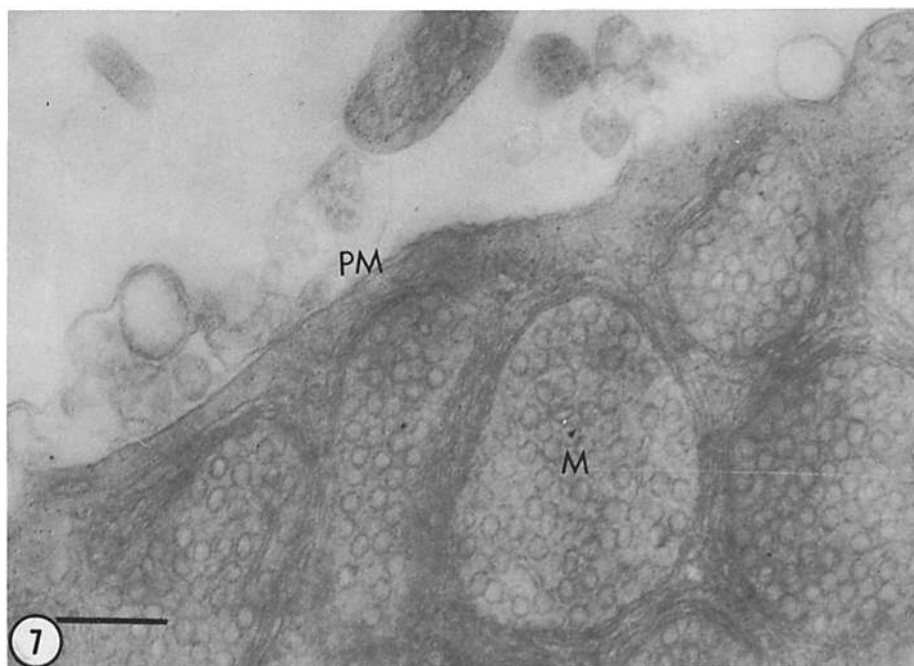

FIGURE 7 Portion of an adrenal cortex cell not exposed to lanthanum. Plasma membrane (PM), mitochondria (M). This section was unstained. Scale $0.25 \mu\text{m}$; $\times 58,000$.

stimulus with enzyme activation. The precise nature of this coupling is not yet known.

In the previous studies with intact cells, two means were utilized to study the role of Ca^{++} in the ACTH-stimulation of cyclic AMP formation: (a) omission of Ca^{++} from the incubation medium, and (b) addition of EGTA, a Ca^{++} chelator, to the incubation medium. Both approaches have the drawback that intracellular processes are also affected by manipulation of Ca^{++} concentrations outside the cell. For example, in Ca^{++} -free medium or in the presence of EGTA, the stimulation of steroidogenesis by cyclic AMP and its dibutyryl derivative is considerably reduced (21, 49). It is likely that when the cells are suspended in a Ca^{++} -free medium, there is a reduction in the intracellular levels of Ca^{++} due to efflux of the cation and that this results in the inhibition of Ca^{++} -dependent processes inside the cell. Indirect support for this contention is provided by our experiments carried out with La^{+++} in a Ca^{++} -free medium. Thus, addition of La^{+++} partly reversed the decrease in the steroidogenic effect of dibutyryl cyclic AMP normally observed in Ca^{++} -free media. In these experiments, La^{+++} presumably prevented the depletion of intracellular Ca^{++} by

blocking efflux of the cation from the cells. Indeed, La^{+++} is known to block both uptake and efflux of Ca^{++} in other intact cell systems (25, 29, 55-57).

Our experiments demonstrate the usefulness of La^{+++} in delineating the role of Ca^{++} in the hormonal regulation of membrane-associated processes. We have carried out experiments in the presence of physiological concentrations of Ca^{++} and under these conditions La^{+++} appears not to interfere with intracellular processes. Thus, La^{+++} in concentrations as high as 1 mM had no effect on stimulation of steroidogenesis by dibutyryl cyclic AMP. It was also without effect on the conversion of three steroid substrates into corticosterone. Since the stimulation of corticosterone formation from steroid substrates by glucose was also not affected, it is unlikely that La^{+++} exerted any notable effects on glucose metabolism and energy production in the cells. The lack of effect of La^{+++} on the intracellular processes measured in this study strongly suggests that La^{+++} does not penetrate the cells. Indeed, the electron microscope localization of La^{+++} exclusively on the cell membrane provides additional support for this view. Our electron microscope studies are in agreement with those of other workers who also

have found La^{+++} to be specifically localized on the plasma membranes of several types of cells (9, 15, 29, 35, 40, 43, 51, 59).

The present data show that La^{+++} inhibits the stimulation of cyclic AMP and corticosterone formation in adrenal cells in response to ACTH. The effects of La^{+++} on corticosterone formation are almost entirely due to the inhibition of cyclic AMP formation since the intracellular processes measured in this study were unaffected by La^{+++} . Also, synthesis of cyclic AMP is more sensitive to La^{+++} than is steroidogenesis. This can be seen clearly in the dose response curves, especially at relatively large concentrations of ACTH. Moreover, in the experiment reported in Fig. 5, $20 \mu\text{M}$ La^{+++} reduced the amount of cyclic AMP formed in response to 100 nM ACTH by almost 90%, whereas reduction in corticosterone was only 20%. These results reinforce the concept of "spare receptors" on the adrenal cell membrane (3, 50). Thus, all of the cyclic AMP produced in response to ACTH may not be necessary to obtain maximal rates of corticosterone formation. Similar suggestions have been made previously by other workers (36, 50).

La^{+++} has proved to be a useful tool in defining the source of Ca^{++} involved in the contractile response of various types of muscles to different stimuli, and the effects of Ca^{++} transport have been well correlated with the uncoupling action of La^{+++} (29, 48, 57). Further, it has been shown that La^{+++} has an affinity for extracellular sites (12, 43) and binds specifically to membrane areas contiguous with the extracellular space without penetrating beyond this region (29, 35, 43, 59). These studies indicate that contractile responses in most muscle systems are regulated by a superficially located and rapidly exchangeable Ca^{++} component. In the present study, inhibition of ACTH-stimulated cyclic AMP formation by La^{+++} and the localization of La^{+++} on the cell membrane strongly suggest that Ca^{++} at superficial membrane sites plays an important role in the regulation of adenylyl cyclase by ACTH. To our knowledge, this is the first time La^{+++} has been shown to have an effect on the hormonal stimulation of cyclic AMP formation.

The existing models for the hormonal regulation of adenylyl cyclase propose either two or three components in the system. In the original model proposed by Robison et al. (44), there are two components, hormone receptor and catalytic unit, with a specific directional orientation. In the more

recent model proposed by Cuatrecasas (11) and based on the premise that biological membranes are in a fluid state (53, 54), the two components are visualized to be relatively free to diffuse laterally along the plane of the membrane. In both models, interaction of hormone-receptor complex with the catalytic component leads to activation of adenylyl cyclase. In the three component models (7, 22, 45) an additional component, termed "transducer" by Birnbaumer et al. (7) and by Rodbell (45), is interposed between the receptor and catalytic component. According to Rodbell (46), the transducer is that element which couples events occurring at the discriminator (receptor) to the events taking place at the amplifier (catalytic unit). To date, the nature of the transducer has remained vague.

Similarities in the proposed roles of Ca^{++} in the "excitation-contraction" coupling and the coupling of ACTH-receptor interaction to the adenylyl cyclase raise the possibility that a contractile protein is involved in the regulation of adenylyl cyclase by those hormones which are known to require Ca^{++} . Thus, the interaction between the hormone-receptor complex and the adenylyl cyclase could be achieved via the intermediate role of a Ca^{++} -sensitive contractile protein component of the membrane (Fig. 8). A role for contractile

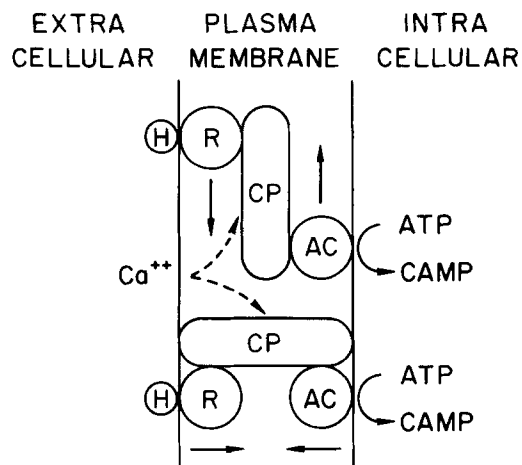

FIGURE 8 Model for the regulation of adenylyl cyclase by those hormones which require Ca^{++} . *H*, hormone; *R*, receptor; *AC*, adenylyl cyclase; *CP*, contractile protein component of the cell membrane. Solid arrows within the plasma membrane indicate that CP could aid lateral as well as transverse motion of HR complex and AC. Broken arrows indicate that Ca^{++} at superficial binding sites on the plasma membrane may be involved in the regulation of CP.

proteins has been proposed in transport processes (37) and the release of transmitter material at synaptic endings (4). It may also be mentioned here that contractile proteins, indeed, have been discovered in a number of nonmuscle cells (42) and the possibility that such proteins may be involved in lateral diffusion of membrane constituents has been recently discussed by others (38, 39).

The contractile protein component need not impose a directional restraint on the coupling of the hormone-receptor complex to the adenylyl cyclase, since it could aid lateral as well as transverse motion of the two moieties as indicated in the model depicted in Fig. 8. In the absence of Ca^{++} the proposed contractile protein would not be functional and, therefore, full activation of adenylyl cyclase will not be realized. On the basis of the experiments described in this paper, the source of Ca^{++} for regulation of the intermediate contractile protein appears to be a superficially located component.

We would like to thank William F. Robidoux, Jr., Sara Seekings, George Gagnon, and Ronald Goldstein for the excellent technical assistance.

This research was supported by grant AM-04899 from the National Institute of Arthritis, Metabolism and Digestive Diseases.

Received for publication 11 June 1975, and in revised form 8 August 1975.

REFERENCES

- ALBANO, J. D. M., G. D. BARNES, D. V. MAUDSLEY, B. L. BROWN, and R. P. EKINS. 1974. Factors affecting the saturation assay of cyclic AMP in biological systems. *Anal. Biochem.* **60**:130-141.
- BAR, H. P., and O. HECHTER. 1969. Adenylyl cyclase and hormone action. III. Calcium requirement for ACTH stimulation of adenylyl cyclase. *Biochem. Biophys. Res. Commun.* **35**:681-685.
- BEALL, R. J., and G. SAYERS. 1972. Isolated adrenal cells: steroidogenesis and cyclic AMP accumulation in response to ACTH. *Arch. Biochem. Biophys.* **148**:70-76.
- BERL, S., S. PUSZKIN, and W. J. NICKLAS. 1973. Actomyosin-like protein in brain. *Science (Wash. D. C.)*. **179**:441-446.
- BIRMINGHAM, M. K., F. H. ELLIOTT, and H. L. P. VALERO. 1953. The need for the presence of calcium for the stimulation *in vitro* of rat adrenal glands by adrenocorticotrophic hormone. *Endocrinology*. **53**:687-689.
- BIRMINGHAM, M. K., E. KURLENTS, R. LANE, B. MUHLSTOCK, and H. TRAIKOV. 1960. Effects of calcium on the potassium and sodium content of rat adrenal glands, on the stimulation of steroid production by adenosine 3',5'-monophosphate, and on the response of the adrenal to short contact with ACTH. *Can. J. Biochem.* **38**:1077-1085.
- BIRNBAUMER, L., S. L. POHL, M. L. KRANS, and M. RODBELL. 1970. The actions of hormones on the adenylyl cyclase system. *Adv. Biochem. Psychopharmacol.* **3**:185-208.
- BOROWICZ, J. L. 1972. Effect of lanthanum on catecholamine release from adrenal medulla. *Life Sci.* **11**:959-964.
- BRIGHTMAN, M. W., and R. S. REESE. 1969. Junctions between intimately apposed cell membranes in the vertebrate brain. *J. Cell Biol.* **40**:648-677.
- BROWN, B. L., R. P. EKINS, and J. D. M. ALBANO. 1972. Saturation assay for cyclic AMP using endogenous binding protein. *Adv. Cyclic Nucleotide Res.* **2**:25-40.
- CUATRECASAS, P. 1974. Membrane receptors. *Annu. Rev. Biochem.* **43**:169-214.
- DOGGENWEILER, C. F., and S. FRENK. 1965. Staining properties of lanthanum on cell membranes. *Proc. Natl. Acad. Sci. U. S. A.* **53**:425-430.
- FARESE, R. V. 1971. On the requirement for calcium during the steroidogenic effect of ACTH. *Endocrinology*. **89**:1057-1063.
- FORMAN, J. D., and J. L. MONGAR. 1972. Dual effect of lanthanum on histamine release from mast cells. *Nat. New Biol.* **240**:255-256.
- GARANT, P. R. 1972. The demonstration of complex gap junctions between the cells of the enamel organ with lanthanum nitrate. *J. Ultrastruct. Res.* **40**:333-348.
- HAGIWARA, S., M. P. HENKART, and Y. KIDOKORO. 1971. Excitation-contraction coupling in amphioxus muscle cells. *J. Physiol. (Lond.)*. **219**:233-251.
- HAKSAR, A., S. BANIUKIEWICZ, and F. G. PÉRON. 1973. Inhibition of ACTH-stimulated steroidogenesis in isolated rat adrenal cells treated with neuraminidase. *Biochem. Biophys. Res. Commun.* **52**:959-966.
- HAKSAR, A., D. V. MAUDSLEY, G. L. KIMMEL and F. G. PÉRON. 1974. ACTH-stimulation of cyclic AMP formation in isolated rat adrenal cells. The role of membrane sialic acid. *Biochim. Biophys. Acta.* **362**:356-365.
- HAKSAR, A., D. V. MAUDSLEY, and F. G. PÉRON. 1975. Stimulation of cyclic AMP and corticosterone formation in isolated rat adrenal cells by cholera enterotoxin. Comparison with the effects of ACTH. *Biochim. Biophys. Acta.* **381**:308-323.
- HAKSAR, A., and F. G. PÉRON. 1972. The possible function of pyruvate in the steroidogenic response of rat adrenal cell suspensions to ACTH, cyclic AMP and dibutyl cyclic AMP. *J. Steroid Biochem.* **3**:847-857.
- HAKSAR, A., and F. G. PÉRON. 1973. The role of

- calcium in the steroidogenic response of rat adrenal cells to ACTH. *Biochim. Biophys. Acta.* **313**:363-371.
22. HECHTER, O., and I. D. K. HALKERSTON. 1964. On the action of mammalian hormones. In *The Hormones*. G. Pincus, K. V. Thimann and E. B. Astwood, editors. Academic Press, Inc., New York. Vol. V. 697-816.
 23. HURWITZ, L., P. D. JOINER, and S. VON HAGEN. 1967. Mechanical responses of intestinal smooth muscle in a calcium-free medium. *Proc. Soc. Exp. Biol. Med.* **125**:518-522.
 24. JAANUS, S. D., R. A. CARCHMAN, and R. P. RUBIN. 1972. Further studies on the relationship between cyclic AMP levels and adrenocortical activity. *Endocrinology.* **91**:887-895.
 25. KALIX, P. 1971. Uptake and release of calcium in rabbit vagus nerve. *Pfluegers Arch. Eur. J. Physiol.* **326**:1-14.
 26. KELLEY, L. A., and S. B. KORITZ. 1971. Bovine adrenal cortical adenyl cyclase and its stimulation by adrenocorticotrophic hormone and NaF. *Biochim. Biophys. Acta.* **237**:141-155.
 27. KIMMEL, G. L., F. G. PÉRON, A. HAKSAR, E. BEDIGIAN, W. F. ROBIDOUX, JR., and M. T. LIN. 1974. Ultrastructure, steroidogenic potential, and energy metabolism of the Snell adrenocortical carcinoma 494. A comparison with normal adrenocortical tissue. *J. Cell Biol.* **62**:152-163.
 28. KOWAL, J., S. SRINIVASAN, and T. SAITO. 1974. Calcium modulation of ACTH and cholera toxin stimulated adrenal steroid and cyclic AMP synthesis. *Endocrine Res. Commun.* **1**:305-319.
 29. LANGER, G. A., and J. S. FRANK. 1972. Lanthanum in heart cell culture: effect on calcium exchange correlated with its localization. *J. Cell Biol.* **54**:441-455.
 30. LAWSON, D. M., and G. H. SCHMIDT. 1972. Effects of lanthanum on ⁴⁵Ca movements and oxytocin-induced milk ejection in mammary tissue. *Proc. Soc. Exp. Biol. Med.* **140**:481-484.
 31. LEFKOWITZ, R. J., J. ROTH, and I. PASTAN. 1970. Effects of calcium on ACTH stimulation of the adrenal: separation of hormone binding from adenyl cyclase activation. *Nature (Lond.)*. **228**:864-866.
 32. LEFKOWITZ, R. J., J. ROTH, and I. PASTAN. 1971. ACTH-receptor interaction in the adrenal: a model for the initial step in the action of hormones that stimulate adenyl cyclase. *Ann. N.Y. Acad. Sci.* **185**:195-209.
 33. LIN, M. T., A. HAKSAR, and F. G. PÉRON. 1974. The role of the Krebs cycle in the generation of intramitochondrial reducing equivalents for the 11 β -hydroxylation of deoxycorticosterone in isolated rat adrenal cells. *Arch. Biochem. Biophys.* **164**:429-439.
 34. MACKIE, C., M. C. RICHARDSON, and D. SCHULSTER. 1972. Kinetics and dose-response characteristics of adenosine 3',5'-monophosphate production by isolated rat adrenal cells stimulated with adrenocorticotrophic hormone. *FEBS Fed. Eur. Biochem. Soc. Lett.* **23**:345-348.
 35. MARTINEZ-PALOMO, A., D. BENITEZ, and J. ALANIS. 1973. Selective deposition of lanthanum in mammalian cardiac cell membranes: ultrastructural and electrophysiological evidence. *J. Cell Biol.* **58**:1-10.
 36. MOYLE, W. R., Y. C. KONG, and J. RAMACHANDRAN. 1973. Steroidogenesis and cyclic adenosine 3',5'-monophosphate accumulation in rat adrenal cells: divergent effects of adrenocorticotropin and its *O*-nitrophenyl sulfonyl derivative. *J. Biol. Chem.* **248**:2409-2417.
 37. OCHS, S. 1972. Fast transport of materials in mammalian nerve fibers. *Science (Wash. D. C.)*. **176**:252-260.
 38. OLSEN, R. W. 1975. Filamentous protein model for cyclic AMP-mediated cell regulating mechanisms. *J. Theor. Biol.* **49**:263-287.
 39. PAINTER, R. G., M. SHEETZ, and S. J. SINGER. 1975. Detection and ultrastructural localization of human smooth muscle myosin-like molecules in human non-muscle cells by specific antibodies. *Proc. Natl. Acad. Sci. U. S. A.* **72**:1359-1363.
 40. PAYTON, B. W., M. V. L. BENNETT, and G. D. PAPPAS. 1969. Permeability and structure of junctional membranes at an electrotonic synapse. *Science (Wash. D. C.)*. **166**:1641-1643.
 41. PÉRON, F. G., and S. B. KORITZ. 1958. On the exogenous requirements for the action of ACTH *in vitro* in rat adrenal glands. *J. Biol. Chem.* **233**:256-259.
 42. POLLARD, T. D., and R. R. WEIHING. 1974. Actin and myosin and cell movement. *CRC Crit. Rev. Biochem.* **2**:1-65.
 43. REVEL, J. P., and M. J. KARNOVSKY. 1967. Hexagonal array of subunits in intercellular junctions of the mouse heart and liver. *J. Cell Biol.* **33**:C7-C12.
 44. ROBISON, G. A., R. W. BUTCHER, and E. W. SUTHERLAND. 1967. Adenyl cyclase as an adrenergic receptor. *Ann. N. Y. Acad. Sci.* **139**:703-723.
 45. RODBELL, M. 1971. Hormones, receptors and adenyl cyclase activity in mammalian cells. In *Colloquium on the Role of Adenyl Cyclase and Cyclic AMP in Biological Systems*. P. Condliffe and M. Rodbell, editors. Fogerty International Center, Govt. Printing Office. 88-95.
 46. RODBELL, M. 1972. Cell surface receptor sites. In *Current Topics in Biochemistry*. C. B. Anfinsen, R. F. Goldberger and A. N. Schechter, editors. Academic Press, Inc., New York. 187-218.
 47. RUBIN, R. P., R. A. CARCHMAN, and S. D. JAANUS. 1972. Role of calcium and adenosine cyclic 3'-5' phosphate in the action of adrenocorticotrophin. *Nat. New Biol.* **240**:150-151.
 48. SANBORN, W. G., and G. A. LANGER. 1970. Specific uncoupling of excitation and contraction in mammalian cardiac tissue by lanthanum. *J. Gen. Physiol.* **56**:191-217.
 49. SAYERS, G., R. J. BEALL, and S. SEELIG. 1972.

- Isolated adrenal cells: adrenocorticotrophic hormone, calcium, steroidogenesis, and cyclic adenosine monophosphate. *Science (Wash. D. C.)*. **175**:1131-1133.
50. SEELIG, S., and G. SAYERS. 1973. Isolated adrenal cortex cells: ACTH agonists, partial agonists, antagonists; cyclic AMP and corticosterone production. *Arch. Biochem. Biophys.* **154**:230-239.
 51. SHEA, S. M. 1971. Lanthanum staining of the surface coat of cells: its enhancement by the use of fixatives containing alcian blue or cetylpyridinium chloride. *J. Cell Biol.* **51**:611-620.
 52. SILBER, R. H., R. D. BUSCH, and R. OSLAPAS. 1958. Practical procedure for estimation of corticosterone or hydrocortisone. *Clin. Chem.* **4**:278-285.
 53. SINGER, S. J. 1974. The molecular organization of membranes. *Annu. Rev. Biochem.* **43**:805-834.
 54. SINGER, S. J., and G. S. NICHOLSON. 1972. The fluid mosaic model of the structure of cell membranes. *Science (Wash. D. C.)*. **175**:720-731.
 55. VAN BREEMAN, C., and P. DE WEER. 1970. Lanthanum inhibition of ⁴⁵Ca efflux from the squid giant axon. *Nature (Lond.)*. **226**:760-761.
 56. WEISS, G. B. 1970. On the site of action of lanthanum in frog sartorius muscle. *J. Pharmacol. Exp. Ther.* **174**:517-526.
 57. WEISS, G. B. 1974. Cellular pharmacology of lanthanum. *Annu. Rev. Pharmacol.* **14**:343-354.
 58. WEISS, G. B., and F. R. GOODMAN. 1969. Effects of lanthanum on contraction, calcium distribution and Ca⁴⁵ movements in intestinal smooth muscle. *J. Pharmacol. Exp. Ther.* **169**:45-55.
 59. ZACKS, S. I. 1970. Direct connections between the T system and the subneural apparatus in mouse neuromuscular junctions demonstrated by lanthanum. *J. Histochem. Cytochem.* **18**:302-304.