

# LAST PLANNER AND CRITICAL CHAIN IN CONSTRUCTION MANAGEMENT: COMPARATIVE ANALYSIS

Lauri Koskela<sup>1</sup>, Roy Stratton<sup>2</sup> and Anssi Koskenvesa<sup>3</sup>

## ABSTRACT

This paper endeavours to compare the Last Planner System of production control and the Critical Chain production management method. This comparison is carried out in the context of construction management. The original prescription and the evolution of the practice are examined regarding both approaches, and the similarities and differences are noted. Based on these considerations, gaps in the two approaches are identified and the potential of a synthesis of them is explored.

## KEY WORDS

Production management, Last planner, Critical chain

## INTRODUCTION

The Last Planner<sup>4</sup> System (LPS) of production control (Ballard & Howell 1998, Ballard 2000) and the Critical Chain Project Management (CCPM) (Goldratt 1997) are two recent additions to the arsenal of production management methods in construction and similar fields. The former has experienced a surprisingly rapid diffusion regarding practical application<sup>5</sup>. The diffusion of the latter in construction has also clearly started.

This paper endeavours to compare the Last Planner System of production control and the Critical Chain project management method in the context of construction management. In contrast to earlier comparison of these methods (Shen and Chua 2008; Stratton et al. 2010), this paper focuses on a conceptual comparison, informed both by literature and the authors' own experience with the methods (Koskenvesa and Koskela 2005; Alsehaimi et al. 2009; Stratton 2009).

The paper is structured as follows. First, these two methods are presented, concentrating on Critical Chain, given that Last Planner has been addressed in numerous earlier papers in IGLC conferences. Then a systematic comparison is presented. The paper ends with conclusions on further work.

---

<sup>1</sup> The University of Salford, Salford, M5 4WT, UK, l.j.koskela@salford.ac.uk

<sup>2</sup> Nottingham Trent University, Nottingham, NG1 4BU, UK, roy.stratton@ntu.ac.uk

<sup>3</sup> Tampere University of Technology, Tampere, Finland, anssi.koskenvesa@mittaviiiva.fi

<sup>4</sup> Last Planner is a registered trademark of Lean Construction Institute

<sup>5</sup> It is indicative that "Last Planner System" has 101 000 occurrences in the Web according to Google (April 28, 2010), and "Critical Chain" correspondingly 90 700. However, not all entries on Critical Chain treat a construction application, whereas most entries on Last Planner do. These occurrences are high in comparison to the 144 000 occurrences of "Critical Path Method", a method that has existed since long.

## **LAST PLANNER SYSTEM**

The Last Planner is the person or group accountable for production unit control, that is, the completion of individual assignments at the operational level (Ballard 1994). The need for the Last Planner was influenced by the apparent loss of knowledge of short term and weekly planning for construction sites with the growth in project planning software packages (Harris and McCaffer 2006). According to Ballard (2000), the Last Planner system “is a philosophy, rules and procedures that can be implemented in practice”.

The concept of Last Planner System has five main integrated elements (Ballard 1997; Ballard 2000; Ballard and Howell 2003; Mossman 2009). When systematically implemented in practice, such components can bring many advantages and add major benefits to construction planning practice:

Master Plan – this is to obtain a general plan and identify all the work packages for the whole project showing the main activities, their duration and sequence.

Phase planning – it is about dividing the master plan into various phases aimed to developing more detailed work plans and provide goals that can be considered targets by the project team. Phase planning is a bridge between the master plan and look ahead planning.

Look ahead Planning – this is about focusing management attention on what is supposed to happen at some time in the future, and to encourage actions in the present that cause that desired future.

Weekly Work Plan – this is the collaborative agreement in respect of production tasks for the next day or week via weekly meetings. Weekly meeting help to plan the work that will be done in the next week bearing in mind the work that is being done now and in the knowledge of the work that is made-ready to be done. The WWP meeting covers the weekly plans, safety issue, quality issue, resources, construction methods, and any problems that occur in the field.

Percent Plan Completed & analysis of reasons for non-completed tasks – this is about improving the project planning by continual assessment and learning from failure. PPC is a measure of the proportion of promises made that are delivered on time. PPC can be calculated as the number of activities that are completed as planned divided by the total number of planned activities, and it is presented as a percentage.

## **CRITICAL CHAIN PROJECT MANAGEMENT**

A central driver for adopting Critical Chain (CC) project management is enabling more predictable and shorter project lead times through a more rational approach to managing uncertainty.

The main conceptual elements of CCPM are presented below in contrast to the Critical Path Method in the context of planning, execution and continuous improvement.

## PROJECT PLANNING

Firstly, CC takes account of resource as well as precedence dependencies in determining the project duration, hence the term critical chain. In Figure 1, the critical path representation (see Fig 1, left) would be denoted by activities 1-3-4, whereas in CC (see Fig 1 right) the critical chain is denoted by 1-3-2-4 due to common resource B. In such cases, the critical chain is shown to be longer than the critical path and all four activities need to be managed accordingly. This first distinction is not the most significant but explains the origin of the name Critical Chain.

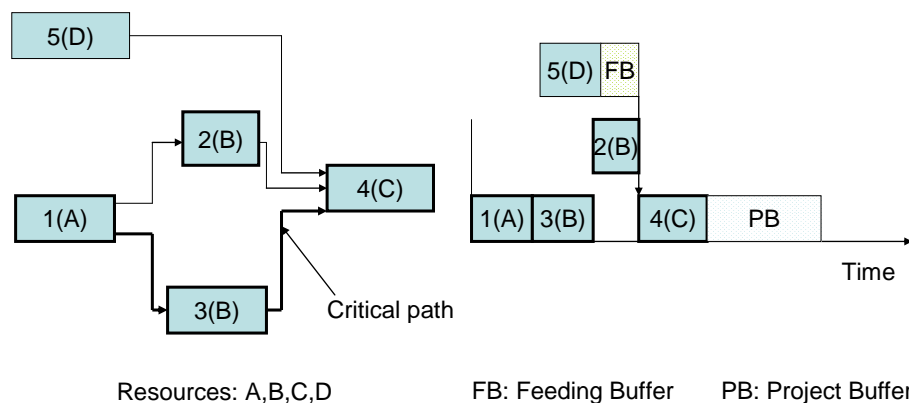

Figure 1: Network diagram and critical chain schedule showing buffers (Stratton, 2009)

Secondly, CC introduces the concept of project and feeder time buffers to support the effective management of time which tends to be inflated at the task level due to the requirement to commit to completing uncertain tasks within a predefined time. Then, having introduced additional time at each task level the time is not effectively managed. The CC approach exploits the fact that it is the project not the task that needs to finish on time. Therefore, by pooling the time buffer across several tasks the size of the protection required is considerably reduced. In CC the project buffer protects the critical chain and feeder buffers are used to ensure that not all activities become critical (see Fig.1). However, in order to address uncertainty in this way the assumption that it is valid to have set task start and finish dates is no longer sustainable.

In dimensioning these buffers, the established start point (Goldratt 2007) is to halve existing activity times, allocating half of the remaining time to the pooled buffers. Therefore, each buffer is equal to a third of the related activity and buffer combination (see Fig. 1 for illustration).

When planning in a multi-project environment, CC advocates staggering the release of projects around a designated resource that acts as a virtual drum. This is used to ensure flow and avoid too many open projects that result in excessive multi-tasking and missed due dates.

## **PROJECT EXECUTION AND CONTINUOUS IMPROVEMENT**

### **Time to complete reporting**

In contrast to the traditional reporting of progress in financial terms (commonly, only weekly or even monthly), CC focuses on reporting the latest projected time to complete each task. Due to this simple reporting requirement it is feasible to report daily.

### **Provide visibility of upcoming tasks**

As there are no intermediate task dates in the planning system the task-time-remaining data provides advanced notice of upcoming tasks (this has previously been referred to as a resource buffer).

### **Current and upcoming tasks are monitored in line with priorities to ensure tasks are effectively progressing.**

In the more complex multi-project environment, there are many in-progress tasks competing for a resource provider's time. In CC these are prioritised in terms of the ratio of critical chain completed to project buffer consumed. In this way current and upcoming tasks can be easily given a relative priority, commonly using green, yellow and red priority colour coding.

### **Buffer consumption is monitored daily by the project manager and recovery action taken where necessary.**

Consumption of the buffer indicates a task is exceeding the ambitious time and that the task manager may need assistance. Action at the project level may be needed to recover a situation.

### **Senior managers monitor the status of all projects and take action where necessary.**

At this level, the priority status of all projects is reviewed periodically to monitor and address higher level programme recovery.

### **Reasons for delay are monitored and provide focus for improvement.**

The relevant reasons for delay can be recorded and used to focus improvement activity. This function, although clearly embedded in earlier TOC manufacturing applications (Schrageheim and Detmer, 2001), has only recently been detailed (Goldratt, 2007) and embedded as a software capability in Concerto amongst others.

## **SUMMARY**

The CC approach can be usefully summarised by the following four functions:

Provide a priority mechanism. The priority of different tasks or projects is set by the simple ratio of project buffer remaining to critical chain remaining. This enables a resource provider to prioritise different tasks within and across projects.

Provide a mechanism for expediting tasks consuming the project buffer. It is important to reduce buffer consumption that can occur in any activity, however, there is effectively only one activity consuming the project

buffer at any time. The improved visibility of buffer consumption creates awareness and opportunity to support the resource concerned and minimise wastage of the buffer at the activity level.

Escalate action when buffer consumption threatens delivery. At the project and programme level the monitoring of the ratio of buffer consumption to completion of the critical chain is used to trigger escalation procedures which would look to review the planning or provide additional resource, possibly temporarily reallocated from a project ahead of schedule.

Target ongoing improvement activity by tracking causes of buffer consumption. As the project(s) progress the causes of delay are recorded, typically using a drop down menu. These are subsequently analysed in the light of the overall project progress so that common causes can be targeted for improvement.

### **CCPM IMPLEMENTATION EVIDENCE**

Case and survey research into the application of CCPM are still very limited. However, one measure of the level of interest in CCPM is the availability of CCPM-capable project management software. There is a growing range of software systems claiming to be CCPM-capable ranging upward in price from \$250. These include: Concerto, ProChain, Spherical Angle, Being Management, Scitor and Advanced Projects Inc.

The supplier of Concerto, Realization, is a leading CCPM provider that has published customers' case studies (Concerto Case Studies 2009). Realisation has also been closely involved in the development of Goldratt's (2007) S&T implementation guide, and the software is closely aligned with it. Using the Realisation Website (Concerto case studies 2010) data, typical benefits include: reduced lead time by 25%; delivery performance increased to 90+%; and increased throughput by 20% with the same resource. Of these few have been formally published with one prominent exception, Warner Robins Air Logistics Centre (Srinivasan et al. 2007), where they implemented CCPM to reduce repair turnaround time on C-5 Galaxy transport aircraft.

Srinivasan et al. (2007) record that, within 8 months of implementing CCPM using Concerto in 2005, the turnaround time was reduced from 240 to 160 days. What is more significant is that this was in addition to the benefits of lean initiatives started in 2000 that reduced the turnaround time from 360 to 240 days. The paper highlights the synergistic relationship between CCPM and lean, with Concerto being used to identify several high-leverage lean events.

A recent notable application of CCPM in the construction sector is through the Japanese government public works programme (Stratton 2009). In Japan CCPM has only recently been available. However, it has rapidly become known for its impact on government construction projects. The use of CCPM has become a prominent part of the win-win-win public works initiative that was introduced nationally in 2009 (Stratton 2009).

## **COMPARISON OF CRITICAL CHAIN AND LAST PLANNER**

Generally, the starting point of development has a dominating impact on the nature and scope of the two considered methods: Last Planner and Critical Chain. The Last Planner method was developed, in a design science research manner, to alleviate the practical problems of construction teams (Koskela and Ballard 2006), whereas Critical Chain originated from an attempt to rectify certain shortcomings of the Critical Path Method. Thus Critical Chain inherits many of the characteristics of the Critical Path Method, Last Planner being more based on a fresh start. In the following, the main similarities and differences of these two methods are analyzed.

### **CONCEPTUALIZATION**

The Critical Path Method is based on a transformation concept of production (Koskela 2000). In this concept, the basic units of analysis, tasks, are atemporal, and mutually independent except precedence relations. The CPM procedure then finds the best order and timing of these tasks. Both Critical Chain and Last Planner subscribe to flow conceptualization, which addresses how work actually flows, in time, through different stages of the project. However, these two methods pick up different foci in flows: Critical Chain mainly operates through aggregated buffers, whereas Last Planner endeavours to reduce the cause of buffers: variability.

CC is a development of the TOC application to manufacturing which, as with lean thinking, is centred on flow. Whereas CPM is cost and resource consumption focused, CC challenges the theoretical basis to CPM and particularly the means by which the CPM deals with variation, uncertainty and cost. In CPM, there is no acknowledgement of the need to manage variation in task times to ensure synchronisation but the focus is on reporting cost based on work completed that is infrequently reported due to the complexity. As with Deming and lean thinking, CC centres on reducing and managing variation by simply reporting the projected time to complete a task. This can be done easily and, therefore, frequently and so it enables synchronisation with other activities and the active involvement of others in expediting progress where necessary.

In turn, Last Planner is using a variety of approaches for reducing flow and process-time variability (Koskenvesa and Koskela 2005; Koskela and Ballard 2006), the overall goal being the reduction of the waste of making-do.

### **PUSH VS. PULL**

Another difference between the methods is that Critical Chain mainly represents a centralized, push mode of management, whereas Last Planner operates more in a decentralized, pull mode. However, both approaches also contain mixed push-pull methods.

Critical Chain thus initially endeavours to push the Master Plan into execution, intermediated through sectoral plans (manpower, procurement, etc.) and lower level plans (extending into weekly and daily plans). CC, as CPM, is centred on a holistic plan regarding task dependency but, unlike CPM, not on task timings. CC acknowledges that there is a need to respond dynamically to uncertain durations, which is not the case with CPM. The focus on reporting projected time to complete frequently (daily recommended) enables priorities to be communicated and action

taken to synchronise dependent activities with appropriate expediting. In this way CC is also characterised by pull, which stresses the need to respond to the customer/system need rather than a predefined forecasted plan associated with push.

In the Last Planner method, the starting point is the situation on site; the site is the engine that is fed, by pulling, in terms of ready tasks, and for creating these different tasks, inputs are pulled. In the Last Planner method, the Master Plan is thus just a resource, rather than something to be executed as such. However, even in the case of Last Planner, the Master schedule and lower level schedules are often used for pushing materials etc. towards the site.

Thus, in CC, although it has inherited the overall orientation to push from the CPM, task execution is pulled, whereas in LP both task execution and task inputs are pulled.

#### **TARGETED SOURCE OF IMPROVEMENT**

In CC, the improvement is thought to come from the active management of buffers, which in the CPM are implicitly in task durations, thus inflating the total duration. By explicating the buffers and by situating them in a strategic manner, it is possible, according to the Critical Chain doctrine, to shorten the duration and also expedite the project.

In the Last Planner method, the main target is to reduce the variability (both flow and process-time variability) of tasks, which reduces the need for buffers, as shown in (Hopp and Spearman 2000). Thus, roughly, Critical Chain pursues an optimized buffer management, but largely accepts the existing variability, whilst Last Planner pursues the reduction of variability through different means embedded in production control, in the first place, although it also covers some buffer management techniques.

#### **TARGETED IMPROVEMENT**

Critical Chain achieves, primarily, a shortening of the duration of a project, and secondarily, other benefits that derive from the shortened schedule. Last Planner achieves increased productivity in tasks and – through reduced variability - increase in plan reliability, which then can be translated into shortened duration.

#### **TREATMENT OF PSYCHO-SOCIAL ISSUES**

Critical Chain addresses such psychological issues as the Student Syndrome, Parkinson's Law and multi-tasking. The means are structural (rather than psychological or social); the project is designed so that these phenomena get mitigated. However, in advanced practice, there is a high extent of visibility that may result in social impacts and psychological impacts. Thus, at any time CC software, such as Concerto, can be interrogated to see the latest projections regarding activity completions together with the projected impact on the buffer. This also indicates the last time an activity was updated, hence whether this is the latest update. This acknowledges that promises may change but also enables proactive involvement of others to support the expediting where necessary.

Last Planner aims to increase the commitment of the responsible persons to implement the planned task, through psychological and social means. These cover public promises, public checking of task completion, and statistics on reasons for non-completions.

## **COVERAGE**

Critical Chain can be used in a situation of several parallel projects (for example, in the case of a subcontractor working on several sites). This means that a subcontractor supporting more than one project or project leg can see the relative priorities through the ratio of CC completed to project buffer consumption and act accordingly.

Last Planner is focusing on one site.

## **LEARNING**

The Last Planner method contains the feature of continuous improvement, triggered by statistics on the nature of reasons for non-completion of weekly tasks.

CC similarly gathers data on reasons for buffer penetration so common causes can be statistically analysed and targeted. Although this is now part of the recent evolution (Stratton 2009), it was not prominent in the early developments.

## **EVOLUTIONARY NATURE OF THE METHOD IN PRACTICE**

Both methods have been further developed by practitioners who have implemented them. Interestingly, converging trends can be discerned, such as the drift to daily level planning and monitoring in Last Planner, the addition of learning to CC, and the increased emphasis on buffer management in the case of Last Planner.

## **SUMMARY**

In summary, this comparison reveals both the thrusts and gaps in the two considered methods, Critical Chain and Last Planner. Regarding thrusts:

Critical Chain primarily endeavours to shorten the project duration, with cost reductions and other benefits as secondary benefits.

Last Planner primarily endeavours to reduce variability in work flows, which is directly leading to increased productivity and thus cost reduction, along with quality and safety gains; furthermore, reduced variability can be used for schedule compression.

Regarding gaps:

Critical Chain is restricted to buffer management; it does not try to reduce the cause of buffers, variability (except through the recently introduced function of continuous improvement). Thus, it does not address the potential for productivity improvement associated to variability reduction through production control.

Last Planner does not contain an explicit link to the Master Plan (Junior et al. 1998); how the situation on site at each moment is reflected in terms of compliance to the Master Plan cannot easily be assessed. In addition, there is no focused method of schedule compression at the Master Plan level.

## **CONCLUSION**

It is evident that when Last Planner and Critical Chain address different aspects of the flow theory of production, they are complementary and invite for a synthesis.



However, instead of a grand synthesis, we discuss here how, respectively, each method could be augmented and extended using principles and methods from the other.

Regarding first Last Planner, we suggest that in time critical projects, explicit attention to the critical path and remaining buffers is added to the agenda of phase planning, look ahead planning and weekly planning. The precise methodology for realizing this remains a task for experimentation and action research.

Regarding Critical Chain, we suggest that for widening the cost decrease opportunities, the pull principles for ensuring that tasks are ready when being started and arrangements geared towards weekly and daily planning across all tasks, rather than just the critical, are implemented. Again, the precise methodology for realizing this remains a task for experimentation and action research although many Last Planner practices would seem to be applicable with little need for adjustment.

In addition to the proposed action research for augmentation of both Last Planner and Critical Chain, there are a number of research topics that arise from analyses made:

How time-consuming and realistic it is to keep track of the arguably constantly changing critical chain in construction projects involving many simultaneous activities with complex mutual dependencies?

Given that Last Planner, Critical Chain and location based techniques such as line of balance method (LBM) (Seppänen 2009) are currently seen as the most promising construction planning and management techniques, is it possible to define such characteristics of a construction project which would favour or disfavour the application of a particular method?

Here, it has been assumed that the field practice of Last Planner and Critical Chain are near to respective prescriptions; ethnographic research would be needed to reveal (inevitable) shortcuts, further developments and possible misunderstandings in practical implementation.

Lastly, it has to be noted that even a brief comparison to location based methods reveals that both Last Planner and Critical Chain continue the tradition of Critical Path Method in abstracting the task location away. Seppänen (2009) suggests that the Last Planner System and location-based management should be implemented together to realize the possible benefits. But even further, could all these methods, CCPM, LBM and LPS, be taken as ingredients for creating an integrated alternative for the Critical Path Method?

## REFERENCES

- Alsehaimi A., Tzortzopoulos P. and Koskela L. (2009). "Last Planner System: Experiences from Pilot implementation in the Middle East." *Proc., 17th IGLC conference*, Taipei, Taiwan.
- Ballard, G. (1994). "The Last Planner." *Spring Conference of the Northern California Construction Institute*, Monterey, CA.
- Ballard, G. and Howell, G. (1998). "Shielding Production: Essential Step in Production Control." *Journal of Construction Engineering and Management*, 124(1),11-17.

- Ballard, G. (1997). "Lookahead Planning, the missing link to production control." *Proceedings 5<sup>th</sup> IGLC Conference*, Griffith University, Gold Coast, Australia.
- Ballard, G. (2000). "The Last Planner System of production control", PhD thesis, University of Birmingham, Birmingham, UK.
- Ballard, G. and Howell, G. (2003). "An update on Last Planner", *Proc., 11th IGLC Conference*, Blacksburg, VA.
- Concerto Case Studies (2009). <<http://www.realization.com/>> (Mar. 24, 2010).
- Goldratt, E. (1997). "Critical Chain", North River Press, MA.
- Goldratt, E.M. (2007). Viewer Notebook: The Goldratt Webcast Program on Project Management.
- Hopp W. and Spearman, M. (2000). "Factory Physics", 2nd Edition, Singapore, McGraw Hill.
- Harris, F. and McCaffer, D. (2006). "Modern Construction Management", 6<sup>th</sup> Edition, Blackwell Science, London.
- Junior, A., Scola, A. and Conte, A. (1998). "Last Planner as a Site Operations Tool", *Proc., 6th IGLC Conference*, Guarujá, Sao Paulo, Brazil.
- Koskela, L. (2000). "An exploration towards a production theory and its application to construction." Espoo, VTT Building Technology, 296 p. VTT Publications 408.
- Koskela, L. and Ballard, G. (2006). "What is Lean Construction – 2006." *Proc., Construction in the XXI Century: local and global challenges*, ARTEC, Rome.
- Koskenvesa, A. and Koskela, L. (2005). "Introducing Last Planner: Finnish Experiences." *Proc., CIB Symposium*, Helsinki, Finland.
- Mossman A. (2009). "Last Planner<sup>TM</sup>: Collaborative conversations for reliable design and construction delivery." <[http://www.thechangebusiness.co.uk/TCB/collaborative\\_programming\\_and\\_programme\\_compression\\_files/LastPlanner2009-05-21.pdf](http://www.thechangebusiness.co.uk/TCB/collaborative_programming_and_programme_compression_files/LastPlanner2009-05-21.pdf)> (May 4, 2010)
- Schragenheim, E. and Detmer, W. (2001). "Manufacturing at warp speed." CRC Press.
- Seppänen, O. (2009). "Empirical Research on the success of Production Control in Building Construction Projects". Helsinki University of Technology, *Structural Engineering and Building Technology*. Helsinki, 187 p.
- Shen, Lijun and Chua, David K. (2008) "An Investigation of Critical Chain and Lean Project Scheduling." *Proc., 16th IGLC Conference*. Manchester, UK.
- Srinivasan, M., Best, W. and Chandrasekaran, S. (2007). "Warner Robins Air Logistics Centre Streamlines Aircraft Repair and Overhaul" *Interfaces*, 37(1), 7-21.
- Stratton, R. (2009). "Critical Chain Project Management – Theory and Practice". *Journal of Project Management and Systems Engineering*, TOC Special Issue, 4, 149-173.
- Stratton, R., Koskela, L., Alsehaimi, A. and Koskenvesa, A. (2010). "Applying manufacturing flow theory to construction management." *Proc., 17th International Annual EurOMA Conference*, Porto.