

*A final manuscript submitted to
IEEE Transactions on Wireless Communications as a letter*

Layered Space-Frequency Equalization in a Single-Carrier MIMO System for Frequency-Selective Channels¹

Xu Zhu, *Student Member, IEEE* and Ross D. Murch², *Senior Member, IEEE*

*Center for Wireless Information Technology
Department of Electrical & Electronic Engineering
The Hong Kong University of Science & Technology
Clear Water Bay, Kowloon, Hong Kong*

2003-02-13

Abstract

Frequency-domain equalization (FDE) has been shown to be an effective approach to combat frequency-selective wireless channels. In this letter we propose a layered space-frequency equalization (LSFE) architecture for a single-carrier (SC) multiple-input multiple-output (MIMO) system, where MIMO FDE is employed at each stage or (layer) of detection. At a particular stage, a group of the best data streams in the minimum mean square error (MMSE) sense are detected and are canceled from the received signals. Simulation results show that our proposed LSFE structures can outperform layered space-time equalization (LSTE) structures and uncoded orthogonal frequency division multiplex (OFDM), especially at a higher delay spread. Performance is enhanced further, by incorporating the FDE with time-domain decision feedback (referred to as FD-DFE) at each stage of LSFE. We also provide performance analysis for LSFE, in comparison with OFDM.

Keywords: frequency-domain equalization (FDE), decision feedback equalization (DFE), multiple-input multiple-output (MIMO), frequency selective.

¹Supported by Hong Kong Research Grants Council HKUST 6048/00E.

²Corresponding Author. Phone: (+852) 2358 7044. Fax: (+852) 2358 1485. Email: eermurch@ee.ust.hk.

I. INTRODUCTION

Frequency domain equalization (FDE) [1-4] for a single carrier (SC) system has been shown to be effective to combat frequency-selective channels, and has been proposed in IEEE 802.16 [5]. Compared to orthogonal frequency division multiplex (OFDM), FDE has similar structure but lower peak-to-average ratio (PAR) and less sensitivity to carrier synchronization [1], and this arises from the use of SC modulation. Compared to time-domain equalization [6-7], FDE requires less complexity to achieve the same performance, especially in highly dispersive channels.

In this letter we propose a layered space-frequency equalization (LSFE) structure for SC multiple-input multiple-output (MIMO) systems over frequency-selective channels, by employing both FDE and successive interference cancellation. At each stage or layer of LSFE, the MIMO FDE scheme is employed to detect a group of the best data streams in the minimum mean square error (MMSE) sense. The output data streams are then canceled from the received signals before they are passed to the next stage.

In previous work, the layered space-time architecture [8] was developed for MIMO systems. The original prototype Vertical Bell Laboratories Layered Space-Time (V-BLAST) [9] was for flat fading channels. It was extended to the environment of frequency-selective channels in [10], where at each stage of detection, a selected data stream is estimated by using the multiple-input single-output (MISO) DFE, and is canceled from the received signals. Further extension was made in [11] by employing MIMO DFE at each stage, and these structures are referred to as layered space-time equalization (LSTE) structures here. For the FDE approach, most work has focused on single-input single-output (SISO) [1-2] or single-input multiple-output (SIMO) [3] systems. In [12], FDE was employed in a MIMO system, where all the signals are detected simultaneously.

Our work is different in that we introduce FDE to the layered structure. Simulation results show that our proposed LSFE structures outperform uncoded OFDM and LSTE, especially at a higher delay spread. The impact of imperfect channel estimation on performance is also demonstrated. Besides, we incorporate FDE with time-domain decision feedback (referred to as FD-DFE), which further enhances the performance. This so-called FD-DFE scheme was originally proposed by [5], however, it was only for SISO systems and no in-depth investigations were made. We also provide performance analysis for LSFE, compared with OFDM.

II. SYSTEM MODEL

We consider an uncoded complex baseband-equivalent MIMO system with K transmit antennas and L receive antennas. Let $d_k[i]$ denote the i th data symbol within a block of M symbols transmitted by the k th ($k=1,\dots,K$) antenna, with unit average symbol energy and symbol period τ . The overall channel memory is assumed to be N , lumping the effects of transmit filter, receive filter and physical channel. Each data block is pre-pended with a cyclic prefix (CP), which is the repetition of the last N symbols of the block. The received signals are sampled at integer time instants, and the CP is discarded to eliminate the inter-block interference (IBI) and to make the channel response appear to be periodic in the frequency domain with period M .

Define $\mathbf{x}[m]$ as the received signal vector of L antenna elements, at the m th time sample as

$$\mathbf{x}[m] = \sum_k \sum_i \mathbf{h}_k[i] d_k[m-i] + \mathbf{n}[m] \quad (1)$$

where $\mathbf{h}_k[i] (i=0,\dots,N)$ is the overall channel impulse response (CIR) with respect to $d_k[m-i]$, and $\mathbf{n}[m]$ denotes the AWGN vector, whose elements have single-sided power spectral density N_0 . The received signals are transferred into the frequency domain, and the Discrete Fourier transform (DFT) of $\mathbf{x}[m]$ is given by

$$\mathbf{X}[m] = \sum_{k=1}^K \mathbf{H}_k[m] D_k[m] + N[m] \quad (2)$$

where $\mathbf{X}[m] = \sum_{i=0}^{M-1} \mathbf{x}[i] e^{-j2\pi im/M}$, $\mathbf{H}_k[m] = \sum_{i=0}^N \mathbf{h}_k[i] e^{-j2\pi im/M}$, $D_k[m] = \sum_{i=0}^{M-1} d_k[i] e^{-j2\pi im/M}$ and $N[m] = \sum_{i=0}^{M-1} \mathbf{n}[i] e^{-j2\pi im/M}$.

III. LAYERED SPACE-FREQUENCY EQUALIZATION

A. Algorithm Description

The system block diagram of the proposed LSFE structure is shown in fig.1, where at each stage the MIMO FD-DFE is employed (FDE is a special case of FD-DFE). We assume that there are J ($1 \leq J \leq K$) detection stages in total. At the j th stage, $m_o^{(j)}$ ($\sum_{j=1}^J m_o^{(j)} = K$) data streams are detected, and are canceled from the received signals. In general this allows tradeoffs between performance and complexity by choosing different $m_o^{(j)}$ for different stages, in a similar way to the LSTE structures described in [11].

Fig.2 illustrates the j th stage of LSFE, where the $m_o^{(j)}$ best data streams in the MMSE sense are detected by using MIMO FD-DFE. The FD-DFE is composed of block-wise FDE and symbol-wise DFE. After discarding the first N received signal vectors that correspond to the cyclic prefix, the M sampled signals at each antenna are first converted from serial to parallel (S/P), and then

transferred into the frequency domain by fast Fourier transform (FFT). A block-wise linear frequency-domain equalizer with LM inputs and $m_o^{(j)}M$ outputs performs channel equalization. The frequency-domain equalized signals are then transferred back to the time domain by inverse FFT (IFFT), and are converted back from parallel to serial (P/S). Before they are input into a decision device denoted by $Q(\cdot)$, a symbol-wise feedback filter (FBF) of memory B with $m_o^{(j)}$ inputs and $m_o^{(j)}$ outputs eliminates the inter-symbol interference (ISI) from the $m_o^{(j)}B$ recently detected symbols, to implement the time-domain symbol-wise DFE. Note that MIMO FD-DFE reduces to FDE when $B=0$, and to MISO when $m_o^{(j)}=1$, and therefore is very general.

In this letter, we focus on three LSFE structures with $J=1, K/2, K$ stages, respectively. This is achieved by setting $m_o^{(j)}=K, 2, 1$ for each stage, respectively. Note that when $m_o^{(1)}=K$ and $B=0$, LSFE reduces to the single-stage FDE in [8], where all the signals are detected simultaneously.

B. Equalizer Design

Our equalizer design and data selection are based on the MMSE criterion. Assuming perfect cancellation of the previously output signals, the modified input signal $X[m]$ at the j th stage is expressed as

$$X[m] = \sum_k \mathbf{H}_k[m] D_k[m] + N[m] \quad (3)$$

where k denotes the summation over the undetected data streams. It should be noted that in practice $X[m]$ may contain errors due to imperfect channel estimation and/or imperfect signal estimation. We assume that at the j th stage, $m_o^{(j)}=m_o$ data streams are selected for detection. Let $d_{k^{(n)}}[i]$ denote the signal transmitted by the $k^{(n)}$ th ($k^{(n)} \in \{1, \dots, K\}$) antenna, which corresponds to the n th ($n=1, \dots, m_o$) output branch of the FD-DFE block. Also let $\tilde{d}_{k^{(n)}}[i]$ and $\hat{d}_{k^{(n)}}[i]$ indicate the soft estimate and hard estimate of $d_{k^{(n)}}[i]$, respectively. Define $\mathbf{d}[i] = [d_{k^{(1)}}[i] \ \dots \ d_{k^{(m_o)}}[i]]^T$ as the detected signal vector, where $(\cdot)^T$ denotes the transpose operation. The soft and hard estimates of $\mathbf{d}[i]$ are denoted by $\tilde{\mathbf{d}}[i] = [\tilde{d}_{k^{(1)}}[i] \ \dots \ \tilde{d}_{k^{(m_o)}}[i]]^T$ and $\hat{\mathbf{d}}[i] = [\hat{d}_{k^{(1)}}[i] \ \dots \ \hat{d}_{k^{(m_o)}}[i]]^T$, respectively.

Let $\mathbf{W}[m]$ ($m=0, \dots, M-1$) denote the FDE weight matrix with respect to the m th frequency tone, which is of dimension $L \times m_o$, and $\mathbf{v}_{k^{(n)}}[m]$ ($m=1, \dots, B$) denote an FBF weight vector with respect to $\hat{d}_{k^{(n)}}[i-m]$. The soft estimate $\tilde{\mathbf{d}}[i]$ can be expressed as

$$\tilde{\mathbf{d}}[i] = \frac{1}{M} \sum_{m=0}^{M-1} \mathbf{W}^H[m] X[m] e^{j2\pi mi/M} - \sum_{n=1}^{m_o} \sum_{m=1}^B \mathbf{v}_{k^{(n)}}^H[m] \hat{d}_{k^{(n)}}[i-m] \quad (4)$$

where $(\cdot)^H$ denotes the complex-conjugate transpose (or Hermitian) of a matrix or a vector.

Both the equalizer coefficients and data selection are determined to minimize

$$\Lambda = E \left\| \tilde{\mathbf{d}}[i] - \mathbf{d}[i] \right\|^2 = \sum_{n=1}^{m_Q} E \left| \tilde{d}_{k^{(n)}}[i] - d_{k^{(n)}}[i] \right|^2 = \sum_{n=1}^{m_Q} MSE_{FD-FDE, k^{(n)}} \quad (5)$$

where $MSE_{FD-FDE, k^{(n)}} = E \left| \tilde{d}_{k^{(n)}}[i] - d_{k^{(n)}}[i] \right|^2$ is the MSE between $\tilde{d}_{k^{(n)}}[i]$ and $d_{k^{(n)}}[i]$.

Before the equalizer design, we define

$$\mathbf{f}_k[m] = \left[\hat{\mathbf{H}}_k^T[0] e^{j2\pi m 0/M} \quad \dots \quad \hat{\mathbf{H}}_k^T[M-1] e^{j2\pi m(M-1)/M} \right]^T \quad (6)$$

where $\hat{\mathbf{H}}_k[m]$ denotes the estimate of $\mathbf{H}_k[m]$. In particular, we have

$$\mathbf{f}_k[0] = \left[\hat{\mathbf{H}}_k^T[0] \quad \dots \quad \hat{\mathbf{H}}_k^T[M-1] \right]^T \quad (7)$$

When deriving the equalizer coefficients, we assume perfect decision feedback (i.e., $\hat{d}_k[i] = d_k[i]$) and perfect channel estimation (i.e., $\hat{\mathbf{H}}_k[m] = \mathbf{H}_k[m]$). As shown in fig.2, let \mathbf{U} denote the $LM \times m_o$ overall FDE weight matrix, which is given by

$$\mathbf{U} = \left[\mathbf{W}^T[0] \quad \dots \quad \mathbf{W}^T[M-1] \right]^T \quad (8)$$

It can be shown that the resulting optimum FDE weight matrix \mathbf{U} is given by

$$\mathbf{U} = \mathbf{\Gamma}^{-1} \mathbf{F}[0] \quad (9)$$

where

$$\mathbf{\Gamma} = \frac{1}{M} \left(\sum_k \sum_{m=0}^{M-1} \mathbf{f}_k[m] \mathbf{f}_k^H[m] - \sum_{n=1}^{m_Q} \sum_{m=1}^B \mathbf{f}_{k^{(n)}}[m] \mathbf{f}_{k^{(n)}}^H[m] \right) + N_0 \mathbf{I} \quad (10)$$

$\mathbf{\Gamma}$ is the autocorrelation matrix of the input signal vector, with perfect decision feedback of the previously detected signals. And

$$\mathbf{F}[0] = \left[\mathbf{f}_{k^{(1)}}[0] \quad \dots \quad \mathbf{f}_{k^{(m_o)}}[0] \right] = \begin{bmatrix} \hat{\mathbf{H}}_{k^{(1)}}[0] & \dots & \hat{\mathbf{H}}_{k^{(m_o)}}[0] \\ \vdots & \ddots & \vdots \\ \hat{\mathbf{H}}_{k^{(1)}}[M-1] & \dots & \hat{\mathbf{H}}_{k^{(m_o)}}[M-1] \end{bmatrix} \quad (11)$$

The optimum FBF weight vector $\mathbf{v}_{k^{(n)}}[m]$ is given by

$$\mathbf{v}_{k^{(n)}}[m] = \frac{1}{M} \mathbf{f}_{k^{(n)}}^H[m] \mathbf{\Gamma}^{-1} \mathbf{F}[0] \quad (12)$$

The resulting MSE with respect to $d_{k^{(n)}}[i]$ is

$$MSE_{FD-FDE, k^{(n)}} = 1 - \frac{1}{M} \mathbf{f}_{k^{(n)}}^H[0] \mathbf{\Gamma}^{-1} \mathbf{f}_{k^{(n)}}[0] \quad (13)$$

Note that when $B=0$, FD-DFE reduces to FDE, and $\mathbf{\Gamma}$ becomes a block diagonal matrix as

$$\mathbf{\Gamma} = \begin{bmatrix} \mathbf{R}[0] & \dots & 0 \\ \vdots & \ddots & \vdots \\ 0 & \dots & \mathbf{R}[M-1] \end{bmatrix} \quad (14)$$

where

$$\mathbf{R}[m] = \sum_k \hat{\mathbf{H}}_k[m] \hat{\mathbf{H}}_k^H[m] + N_0 \mathbf{I} \quad (15)$$

$\mathbf{W}[m]$ can be simply expressed as

$$\mathbf{W}[m] = \mathbf{R}^{-1}[m] \begin{bmatrix} \hat{\mathbf{H}}_{k(1)}[m] & \dots & \hat{\mathbf{H}}_{k(m_o)}[m] \end{bmatrix} \quad (16)$$

This implies that the FDE weight matrix for each frequency tone is uncorrelated with each other. The MSE in (13) reduces to

$$MSE_{FDE,k(n)} = 1 - \frac{1}{M} \sum_{m=0}^{M-1} \hat{\mathbf{H}}_{k(n)}^H[m] \mathbf{R}^{-1}[m] \hat{\mathbf{H}}_{k(n)}[m] \quad (17)$$

IV. PERFORMANCE ANALYSIS

To determine the performance of LSFE, we first investigate the equalizer output signal to interference-and-noise ratio (SINR) at a particular stage. Without loss of generality, we assume QPSK modulation. Let γ_k denote the output SINR with respect to the detected signal $d_k[m]$. The corresponding bit error rate (BER) can be approximated by $BER_k = Q(\sqrt{\gamma_k})$. For an unbiased MMSE filter [6], it can be shown that the output SINR can be related to the MSE by $\gamma_k = \frac{1}{MSE_k} - 1$. Using the Gaussian tail function and further approximations, for a high SNR the BER can be upperbounded by

$$BER_k \leq \exp(-\gamma_k) \quad (18)$$

We first compare the performance of the FDE ($B=0$) based LSFE and its FD-DFE ($B>0$) based equivalent, assuming perfect cancellation of the previously output signals and perfect decision feedback from the FBF (for FD-DFE). Let ΔMSE_k denote their MSE difference with respect to $d_k[m]$, which is given by:

$$\Delta MSE_k = MSE_{FDE,k} - MSE_{FD-DFE,k} = \frac{1}{M} \mathbf{f}_k^H[0] \mathbf{D} \mathbf{f}_k[0] \quad (19)$$

where $\mathbf{D} = \mathbf{\Gamma}_{FDE}^{-1} - \mathbf{\Gamma}_{FD-DFE}^{-1}$, with $\mathbf{\Gamma}_{FDE}$ and $\mathbf{\Gamma}_{FD-DFE}$ given by (14) and (10), respectively. It can be easily shown that \mathbf{D} is nonnegative definite, and therefore $\Delta MSE_k \geq 0$. Thus, the BER of FD-DFE is guaranteed to be the same or better than the BER of FDE.

The BLAST-like OFDM structure has been developed in [13], where at each stage and for each subcarrier, the data symbol with the smallest MSE is detected and output. The received signals are updated by canceling the interference of the output signals. To compare with LSFE, we generalize this layered OFDM structure by employing an arbitrary number of output data symbols for each subcarrier at each stage. Similar to LSFE, with K , $K/2$ and 1 output symbols per

subcarrier at each stage, we achieve the $J=1$, $K/2$ and K -stage OFDM structures, respectively. Note that the K -stage OFDM is the same as the BLAST-like OFDM structure in [13].

Comparing a particular stage of the FDE based LSFE to its OFDM counterpart, the main hardware difference is that the IFFT block is moved from the receiver to the transmitter. Therefore, both the structures have the same coefficients and similar complexity. It is interesting to compare the performance of the FDE based LSFE and OFDM. At a particular stage, the MSE with respect to the m th OFDM symbol (or subcarrier) transmitted by the k th antenna is given by

$$MSE_{OFDM,k,m} = 1 - \hat{\mathbf{H}}_k^H[m] \mathbf{R}^{-1}[m] \hat{\mathbf{H}}_k[m] \quad (20)$$

The corresponding output SINR is

$$\gamma_{OFDM,k,m} = \frac{1}{MSE_{OFDM,k,m}} - 1 \quad (21)$$

Substituting (21) into (18), the BER corresponding to the m th OFDM symbol transmitted by the k th antenna is bounded by $BER_{OFDM,k,m} \leq \exp\left(1 - \frac{1}{MSE_{OFDM,k,m}}\right)$. The average BER of OFDM with given channel realization is determined by averaging over all the symbols, which is bounded by:

$$BER_{OFDM,k} = \frac{1}{M} \sum_{m=0}^{M-1} BER_{OFDM,k,m} \leq \frac{1}{M} \sum_{m=0}^{M-1} \exp\left(1 - \frac{1}{MSE_{OFDM,k,m}}\right) \quad (22)$$

Comparing (17) and (20), we notice that the MSE for each FDE symbol is the average of MSEs for all the OFDM symbols, i.e.,

$$MSE_{FDE,k} = \frac{1}{M} \sum_{m=0}^{M-1} MSE_{OFDM,k,m} \quad (23)$$

Thus, the SNR with respect to the FDE symbol transmitted by the k th antenna is

$$\gamma_{FDE,k} = \frac{1}{MSE_{FDE,k}} - 1 = \frac{1}{\frac{1}{M} \sum_{m=0}^{M-1} MSE_{OFDM,k,m}} - 1 \quad (24)$$

Using (18) and (24), the upper bound on the BER of FDE is given by

$$BER_{FDE,k} \leq \exp\left(1 - \frac{1}{\frac{1}{M} \sum_{m=0}^{M-1} MSE_{OFDM,k,m}}\right) \quad (25)$$

which should be compared to (22).

To gain an insight into the relation between the FDE based LSFE and the equivalent OFDM, we first consider the special case of flat fading environment ($N=0$), where the channel frequency response $\mathbf{H}_k[m]$ reduces to the CIR denoted by \mathbf{h}_k which is an $L \times 1$ vector. Thus, at a particular

stage both the LSFE and OFDM structures reduce to a linear MMSE detector. Each symbol transmitted by the k th antenna has the same MSE given by

$$MSE_k = 1 - \hat{\mathbf{h}}_k^H \mathbf{R}^{-1} \hat{\mathbf{h}}_k = \left(1 + \hat{\mathbf{h}}_k^H \mathbf{R}_k^{-1} \hat{\mathbf{h}}_k \right)^{-1} \quad (26)$$

where $\hat{\mathbf{h}}_k$ denotes the estimate of \mathbf{h}_k , $\mathbf{R} = \sum_n \hat{\mathbf{h}}_n \hat{\mathbf{h}}_n^H + N_0 \mathbf{I}$ and $\mathbf{R}_k = \sum_{n \neq k} \hat{\mathbf{h}}_n \hat{\mathbf{h}}_n^H + N_0 \mathbf{I}$. Both the FDE based LSFE and OFDM have the same BER upper bounded by

$$BER_k \leq \exp\left(-\hat{\mathbf{h}}_k^H \mathbf{R}_k^{-1} \hat{\mathbf{h}}_k\right) \quad (27)$$

Therefore, the FDE based LSFE and its OFDM equivalent have the same performance in flat fading. By averaging the conditional BER over the fading channel statistics, the average BER can be obtained, which has been studied [14-15] intensively.

In frequency-selective channels, by approximating the elements of the discrete-time CIR as i.i.d. zero-mean complex Gaussian random variables, γ_{OFDM,k_m} has chi-square distribution with $2L$ degrees of freedom [14]. Thus, the average BER of OFDM can be approximated by its BER for flat fading. For LSFE, however, frequency diversity can be achieved to provide enhanced BER, although it is difficult to express the distribution of the output SINR given by (24) and therefore not possible to give the exact average BER by taking the integral of the conditional BER multiplied by the probability density function of the output SINR. Comparing the output SINRs for OFDM in (21) to that of FDE in (24), it suggests that less fluctuation of SINR is likely to yield better average BER performance.

It should be noted that in flat fading channels the conventional DFE also provides the same performance as FDE and OFDM, with the FBF weight equal to zero. However, it can be deduced from (12) that the FBF weight in FD-DFE is non-zero which may lead to some error propagation.

V. SIMULATION RESULTS

We use simulation results to show performance of LSFE, by focusing on the three structures described in section II-A. We employ $K=4$ transmit antennas and $L=4$ receive antennas. Each data block consists of $M=64$ QPSK symbols, with a symbol rate of 1.25 Mbaud (i.e., a symbol period of $T=0.8\mu s$). Both the transmit and receive filters use a raised-cosine pulse with a roll-off factor of 0.35. The physical channel is modeled by following the exponential power delay profile [11] with an RMS delay spread σ . The overall channel is of memory $N=6$. The SNR is defined as the spatial average ratio of the received signal power to noise power.

Comparisons are performed with the uncoded OFDM based layered structures, which have been described in section IV. As the equivalents of LSFE, we use OFDM structures with $J=1,2$

and 4 stages. We also investigate the performance of the 1-stage and 4-stage LSTE, which has the same structure as LSFSE except that the FD-DFE or FDE at each stage is replaced by DFE. The 1-stage DFE structure has been extensively investigated [16-17], where MIMO DFE is used to detect all the signals simultaneously. The 4-stage LSTE structure was developed in [11], where MISO DFE is utilized to detect a selected data stream at each stage. All the DFE blocks employ a symbol-spaced feedforward filter (FFF) of memory $F=4$ and an FBF of memory $B=4$. The decision delay of DFE is optimized by using the scheme in [11] for each stage.

In fig.3, we demonstrate the performance of the 1-stage and 4-stage FD-DFE based LSFSE structures ($B>0$), compared to their FDE based counterparts ($B=0$). Perfect channel state information (CSI) is assumed. We consider a typical urban environment where the RMS delay spread is $\sigma = 1\mu s$. Thus, the RMS delay spread normalized to the symbol period is $\sigma/T = 1.25$. The 4-stage FDE outperforms the 1-stage FDE in [8] with an SNR gain of around 5dB at BER=1e-4, benefiting from the increased degree of freedom stage by stage. By employing an FBF, the 1-stage FD-DFE also increases the degree of freedom and therefore provides much better performance than 1-stage FDE, with an SNR gain of over 3dB for $B=1$ and 5dB for $B=4$ at BER=1e-4. The 4-stage FD-DFE ($B=4$) yields the best performance, with a small SNR gain of less than 1dB over both the 4-stage FDE and 1-stage FD-DFE ($B=4$) at BER=1e-4. It can be deduced that the use of FBF yields fewer contributions to the performance enhancement of the multistage LSFSE, since much of the performance gain has been achieved.

Fig.4 demonstrates the impact of channel estimation error on the performance, by using the 1-stage and 4-stage FDE based LSFSE ($B=0$). We use the least-squares (LS) frequency-domain channel estimation scheme in [8], where each antenna transmits a training sequence of a moderate length M (with a length- N CP) simultaneously. The training sequences are designed such that each one occupies M/K mutually exclusive frequency tones. Thus, the channel estimation for the MIMO system reduces to multiple SISO channel estimations. In fig.4, dashed lines indicate imperfect CSI. The channel estimation scheme provides reasonable accuracy, especially at a higher SNR. It can also be shown that the channel estimation accuracy is insensitive to the change of training sequence length when the length is above a moderate value. Besides, the multistage LSFSE is more susceptible to imperfect CSI, which worsens the effect of error propagation. For instance, at BER=1e-3, the performance losses for 1-stage and 4-stage LSFSE are around 0.4dB and 1.2dB, respectively. For comparison, we also provide the average BER of the 4-stage FDE with both perfect CSI and perfect interference cancellation. It shows that the

multistage structure with imperfect interference cancellation has the same diversity order as the one with perfect interference cancellation, assuming perfect CSI. This implies that the overall performance of multistage LSFE is mainly determined by its first stage.

Fig.5 illustrates the performance of the 1-stage, 2-stage and 4-stage FDE-based LSFE structures ($B=0$) compared to the performance of their uncoded OFDM counterparts, with perfect CSI and an RMS delay spread of $\sigma=1.25T$. All the LSFE structures outperform their uncoded OFDM counterparts, by achieving frequency diversity without coding. At BER= $1e-4$, the 4-stage FDE outperforms the 4-stage OFDM by about 3dB. In particular, the 2-stage FDE has better performance and less complexity than the 4-stage OFDM at a higher SNR.

Fig.6 shows performance of the 1-stage and 4-stage LSFE ($B=0,1,4$), OFDM and LSTE ($F=4,B=4$), in terms of BER versus the normalized RMS delay spread, at a fixed SNR=20dB. We assume that all the structures have the same overhead (due to training/CP) and long enough but moderate training sequences to allow channel estimation error to be ignored at a high SNR. As discussed in section IV, in flat fading (i.e., $\sigma=0$) the performance of the FDE based LSFE, OFDM and LSTE converge, while the FD-DFE based LSFE structures have a small performance loss due to error propagation in the FBF. In frequency-selective channels ($\sigma>0$), however, the LSFE structures outperform the others. They also provide better performance than in flat fading by achieving frequency diversity, especially at a higher normalized delay spread. Besides, the 1-stage FD-DFE ($B=4$) outperforms the 4-stage FDE ($B=0$) when $\sigma/T>1.1$, and has the trend to outperform the 4-stage FD-DFE with the increase of delay spread. The performance of OFDM is relatively robust to the change of delay spread, slightly degrading from the flat fading case. The DFE based LSTE structures provide similar results to their LSFE counterparts at a lower delay spread, by exploiting the channel memory with an FBF. As the delay spread increases, however, less channel energy is captured by the FBF and the LSTE structures suffer from severe performance degradation. It should be noted that the DFE based LSTE structures with ($F=4,B=4$) have comparable complexity with the FDE based LSFE structures. This suggests that the FDE based LSFE is superior to the DFE based LSTE with comparable complexity especially with a higher delay spread.

VI. CONCLUSIONS

In this letter we propose the LSFE architecture for a SC MIMO system over frequency-selective channels, by employing the MIMO FDE or FD-DFE at each stage. Simulation results show significant performance gains of the LSFE structures over LSTE and uncoded OFDM

structures especially at a higher delay spread, which allows the use of a higher data rate and tradeoffs between the performance and complexity. It is shown that the FDE based multistage LSFE structure has enhanced performance over the previous single-stage FDE structure. FD-DFE is more suitable for a high data rate system in terms of both performance and complexity. Further, it can be deduced that the overall performance of multistage LSFE is mainly determined by its first stage. Additionally, the multistage LSFE structures are more vulnerable to channel estimation errors.

REFERENCES

- [1] H. Sari, G. Karam and I. Jeanclaude, "Transmission techniques for digital terrestrial TV broadcasting." *IEEE Commun. Mag.*, vol.33, pp.100-9, Feb. 1995.
- [2] G. Kadel. "Diversity and equalization in frequency domain a robust and flexible receiver technology for broadband mobile communication systems". *IEEE VTC'97*, vol.2, pp.894-8, New York, USA.
- [3] M.V. Clark. "Adaptive frequency-domain equalization and diversity combining for broadband wireless communications", *IEEE J. Sel. Areas Commun.*, vol.16, pp.1385-95, Oct. 1998.
- [4] D. Falconer, S.L. Ariyavisitakul, A. Benyamin-Seeyar and B. Eidson, "Frequency domain equalization for single-carrier broadband wireless systems", *IEEE Commun. Mag.*, vol. 40, pp.58-66, Apr. 2002.
- [5] "IEEE 802.16a/b Amendment to the 802.16 Standard Air Interface for Fixed Broadband Wireless Access Systems", Jun., 2001.
- [6] J.M. Cioffi, G.P. Dudevoir, M. Vedat Eyuboglu and G.D. Forney, "MMSE decision-feedback equalizers and coding. I. Equalization results", *IEEE Trans. Commun.*, vol. 43, oct. 1995, pp. 2582-94.
- [7] G. D. Forney, "Maximum-likelihood sequence estimation of digital sequences in the presence of intersymbol interference", *IEEE Trans. Inf. Theory*, vol.IT-18, pp.363-78, May 1972.
- [8] G.J. Foschini, "L"Layered space-time architecture for wireless communication in a fading environment when using multiple antennas", *Bell Labs Tech. J.*, vol.1, pp. 41-59, Autumn 1996.
- [9] G.D. Golden, C.J. Foschini, R.A. Valenzuela and P.W. Wolniansky, "Detection algorithm and initial laboratory results using V-BLAST space-time communication architecture," *Electron. Lett.*, vol.35, pp.14-16, Jan. 7, 1999.
- [10] A. Lozano and C. Papadias, "Space-time receiver for wideband BLAST in rich-scattering wireless channels", in *Proc. IEEE VTC'00*, Japan, May, 2000, pp186-190.
- [11] X. Zhu and R.D. Murch, "MIMO-DFE based BLAST over frequency selective channels", in *Proc. IEEE GLOBECOM'01*, vol.1, pp.499-503, San Antonio, USA, Nov. 2001.
- [12] P. Vandenameele, L. Van der Perre, B. Gyselinckx, M. Engels, M. Moonen and H. De Man, "A single-carrier frequency-domain SDMA basestation", in *Proc. IEEE ICASSP'00*, vol.6, pp.3714-17, Piscataway, USA, May 2000.
- [13] P. Vandenameele, L. Van der Perre, B. Gyselinckx, M. Engels, M. Moonen and H. De Man, "A combined OFDM/SDMA approach", *IEEE J-SAC*, vol.18, Nov. 2000, pp.2312-21.
- [14] J.H. Winters, J. Salz and R.D. Gitlin. "The impact of antenna diversity on the capacity of wireless communication systems". *IEEE Trans. Commun.*, vol.42, pt.3, Feb.-April 1994, pp.1740-51.
- [15] J.H. Winters, J. Salz, "Upper bounds on the bit-error rate of optimum combining in wireless systems". *IEEE Trans. Commun.*, vol.46, Dec. 1998, pp.1619-24.
- [16] N. Al-Dhahir and A. H. Sayed, "The finite-length multi-input multi-output MMSE-DFE", *IEEE Trans. Signal Process.*, vol.48, Oct. 2000, pp.2921-36.
- [17] C. Tidestav, M. Sternad and A. Ahlen, "Reuse within a cell-interference rejection or multiuser detection?" *IEEE Trans. Commun.*, vol.47, Oct. 1999, pp.1511-22.

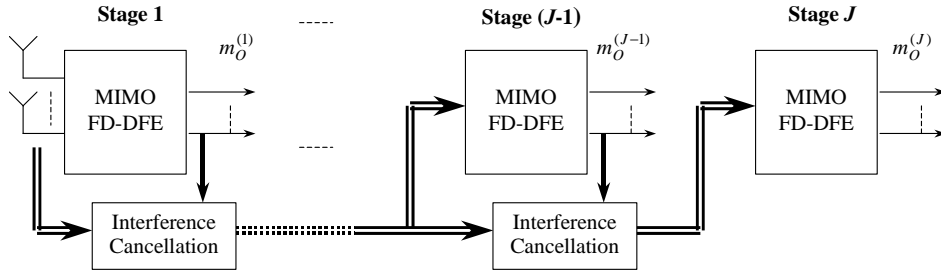

Fig.1: Block diagram of LSFE with $m_O^{(j)}$ ($j=1,\dots,J$) output data streams for the j th stage (FDE is a special case of FD-DFE)

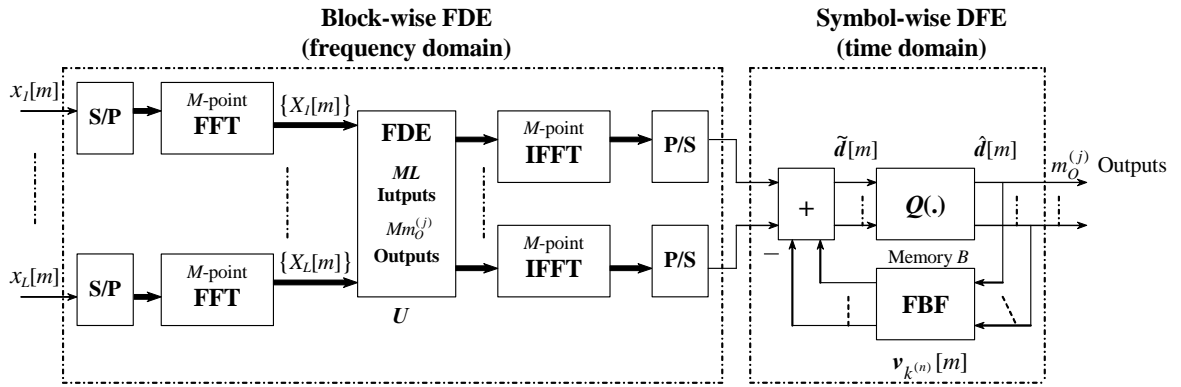

Fig.2: Block diagram of FD-DFE for the j th stage of LSFE with $m_O^{(j)}$ output data streams (FD-DFE reduces to FDE when $B=0$)

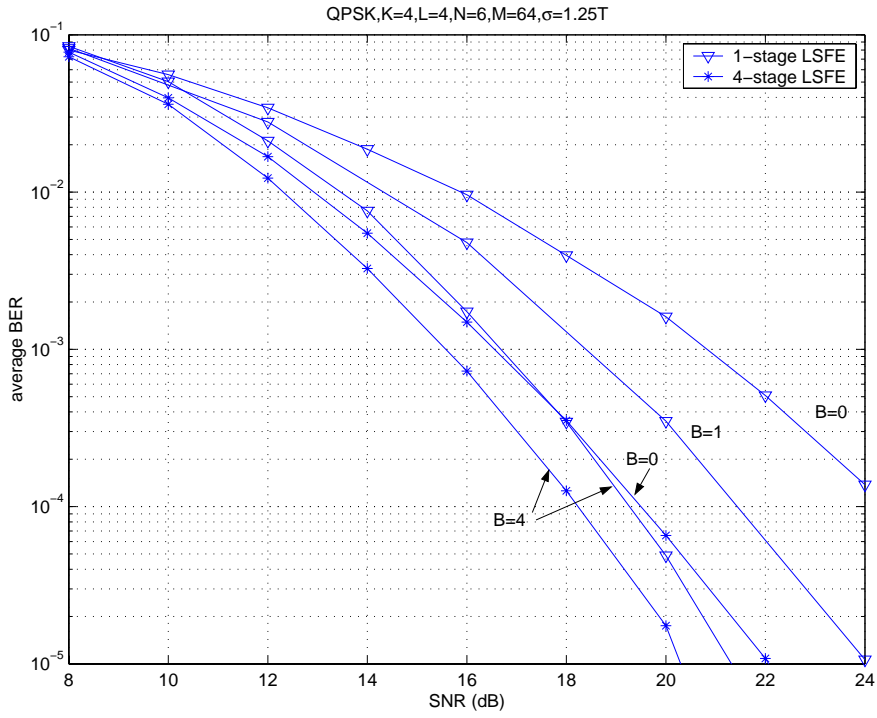

Fig.3: Performance of the 1-stage and 4-stage LSFE ($B=0,1,4$) with $K=4, L=4$, RMS delay of $\sigma=1.25T$ and perfect CSI

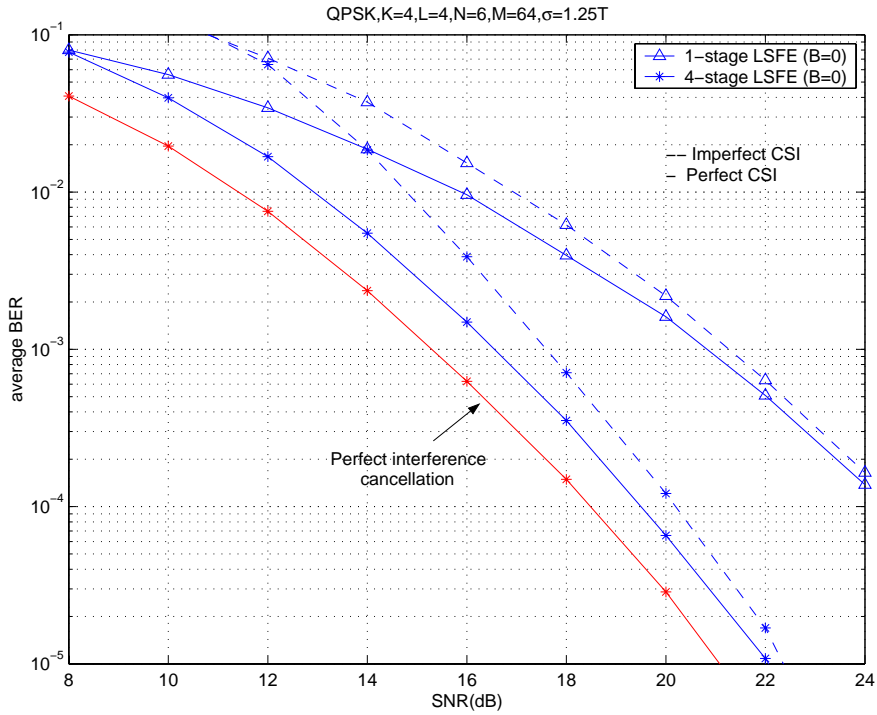

Fig.4: Impact of imperfect channel estimation and imperfect interference cancellation on performance of the 1-stage and 4-stage LSFE ($B=0$) with $K=4, L=4$, and RMS delay of $\sigma=1.25T$

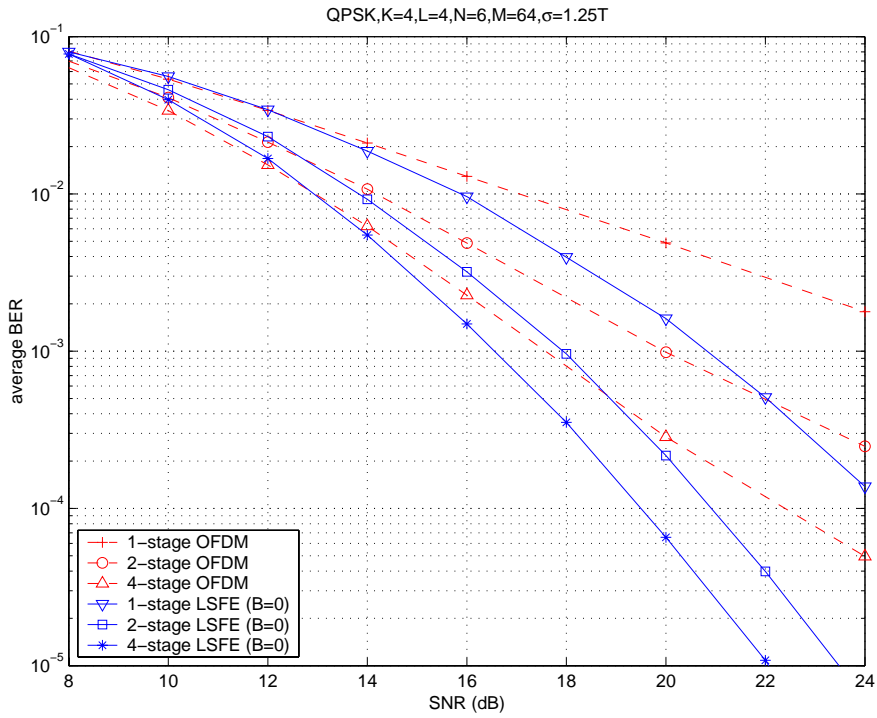

Fig.5: Performance of the 1-stage, 2-stage and 4-stage OFDM and LSFE ($B=0$) with $K=4, L=4$, RMS delay of $\sigma = 1.25T$ and perfect CSI

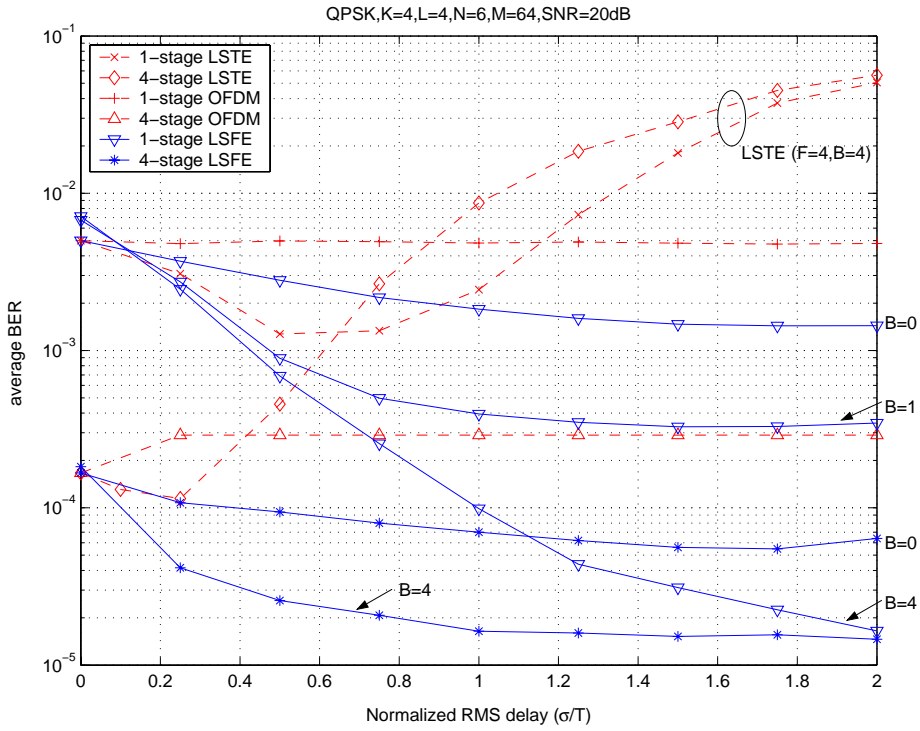

Fig.6: Performance of the 1-stage and 4-stage LSFE ($B=0,1,4$), OFDM, and LSTE ($F=4, B=4$) with $K=4, L=4$ and $SNR=20dB$