

# LDACS1 FOR APNT – PLANNING AND REALIZATION OF A FLIGHT MEASUREMENT CAMPAIGN

*Dmitriy Shutin, Nicolas Schneckenburger, Michael Schnell*  
*German Aerospace Center (DLR), 82234 Wessling, Germany*

## Abstract

Recently, it has been proposed to extend the functionality of the future L-band Digital Aeronautical Communication System type 1 (LDACS1) to allow for navigational services. Specifically, the LDACS1 system can be modified to provide an Alternative Positioning, Navigation, and Timing (APNT) service for aeronautics during possible GNSS (Global Navigation Satellite System) outages. In this paper, we outline the main steps behind the measurement campaign aimed at validating and testing in realistic scenarios the LDACS1 proposal for navigation. We describe the measurement setup, synchronization of stations, and calibration of the measurement equipment.

## Introduction

Currently, aeronautical communications and navigation are undergoing a major renovation process to assist the modernization of Air-Traffic Management (ATM) as developed under NextGen [1] and SESAR [2] in US and Europe, respectively.

For air/ground communications, currently two candidate systems are under consideration for the L-band Digital Aeronautical Communication System (LDACS) [3]: the LDACS type 1 (LDACS1) and LDACS type 2 (LDACS2) systems. The LDACS1 system employs a broadband transmission using Orthogonal Frequency-Division Multiplexing (OFDM), whereas the LDACS2 system is a narrowband single-carrier system. For navigation, ICAO recommends the further development of Global Navigation Satellite System (GNSS) based technologies as primary means for navigation. It is foreseen to employ GNSS not only for area navigation, but also for approach, take-off, and landing. In order to achieve the required navigation performance in terms of precision, continuity, and integrity, augmentation systems are used to assist

GNSS, e.g., Satellite Based Augmentation System (SBAS), Advanced Receiver Autonomous Integrity Monitoring (A-RAIM), or Ground Based Augmentation System (GBAS). In this way, GNSS-based navigation is expected to cover even CAT III landings in the future.

The drawback of GNSS is its inherent single point of failure – the satellite. Due to the large separation between navigational satellites and aircraft, the received power of GNSS signals on the ground is very low. As a result, the signal can be easily jammed by terrestrial systems. Yet the navigation services must be available with sufficient performance for all phases of flight. Therefore, during GNSS outages, or blockages, an alternative solution is needed. This is commonly referred to as Alternative Positioning, Navigation, and Timing (APNT).

A possible APNT solution is to increase the density of Distance Measuring Equipment (DME) [4] stations, which are currently used as primary radio-navigational aids, and perform multilateration with the DME signals. This approach has two main disadvantages: (i) it requires a costly extension of the DME infrastructure, and (ii) it might severely impact the sustainable use of the L-band for communications as foreseen within ICAO. Specifically, the L-band will be used more intensively by DME, which will in turn make it difficult, if not impossible, to allocate sufficient spectrum resources for covering the growing demand for digital communications expected on a mid- and long-term.

Another approach towards APNT is to integrate navigation functionality into the new L-band communication system, specifically into LDACS1 [5]. This way, APNT is covered by LDACS1 and additional DME ground stations are not necessary. The ground infrastructure for APNT is deployed

through the implementation of LDACS1 ground stations. In addition, provided the LDACS1 can reliably cover the navigation function, an extension of the DME infrastructure for APNT is not necessary and even partial removal of DME ground stations might be possible. In this case, the L-band spectrum available for communications is increased and a sustainable use of the L-band for communications is assured.

In order to validate the LDACS1-based proposal for the APNT service, the German Aerospace Center has initiated a research project, termed LDACS-NAV. Its aim is to implement the core structure of the LDACS1 system for navigation and test its performance in a realistic scenario. Specifically, it is planned to perform a flight measurement test with a core LDACS1 ground infrastructure and an airborne receiver. The flight campaign is scheduled for November 2012. Within this paper we provide a short outline of the planned measurement campaign and describe the key challenges that are to be addressed.

## Description of the Measurement Setup

The goals of the measurement campaign are (i) to demonstrate the accuracy that is achievable with LDACS1 communication signals in practical scenarios, and (ii) validate the concept of LDACS-based navigation as a future APNT service.

The future LDACS1-based navigation service would require a ranging to a minimum of four stations to estimate the aircraft position and clock offset at the receiver. Thus, the measurement setup will include four Ground Stations (GS); the receiver will be placed in a research aircraft, a Dassault Falcon 20, provided by the German Aerospace Center.

- The measurement setup can be roughly classified into four major components:
- Ground infrastructure, which includes placement of the GSs and their organization;
- Airborne infrastructure, which includes proper timing of the receiver recording equipment, certification of the equipment for deployment in an aircraft, and recording of the reference navigation data

for validating the performance of the LDACS-based navigation,

- Time-synchronization concept for ground and airborne equipment, and, finally,
- Processing of the measurement data.

In the following, we provide a more detailed description of all these components.

## Ground Infrastructure

The four GSs are located south-west of Munich in southern Germany. The first station will be placed at the German Aerospace Center research site Oberpfaffenhofen (Station A) at (48° 5'8.91"N, 11°16'37.46"E); the other stations are located in Markt Oberdorf (Station B) at (47°45'5.53"N, 10°38'48.20"E), in Bad Wörishofen (Station C) at (48° 0'58.99"N, 10°36'48.63"E), and in Weilheim (Station D) at (47°50'4.57"N, 11° 6'59.38"E), see Figure 1.



**Figure 1. Placement of the Ground Stations**

The distances between the GSs are summarized in Table 1.

**Table 1. Distances Between the GSs**

Distance, km	B	C	D
from/to			

A	60	50	30
B		30	36
C			43

Each station will send an LDACS1 signal with 10W transmit power. Assuming the implementation losses at the receiver and transmitter to be 6dB, we can assess the link budget of the setup, see Figure 2. Observe that for the chosen placement of the GSs the received signal level varies between -70dBm, when the aircraft is over the GS at a height of approx. 2 km, to -100dBm when the distance to the GS is approx. 80km. Thus, we expect the dynamic range of the received signal to be approx. 30-40dB.

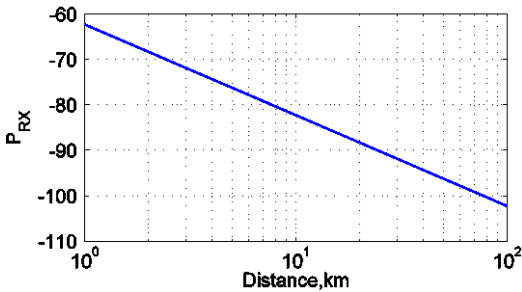

**Figure 2. Link Budget for the Considered Setup**

All GSs will operate in the frequency range between 965MHz and 975MHz. As LDACS1 employs frequency division, the individual LDACS1 GS channels, which occupy a 500 kHz bandwidth, will be equally spaced in this frequency range.

To generate the signals at each station we will employ an Arbitrary Waveform Generator (AWG) SMBV100A, manufactured by Rohde&Schwarz [6]. The signals will be first synthesized in Matlab following the LDACS1 specifications, and then modulated by the AWG to the corresponding carrier frequency, see Figure 3.

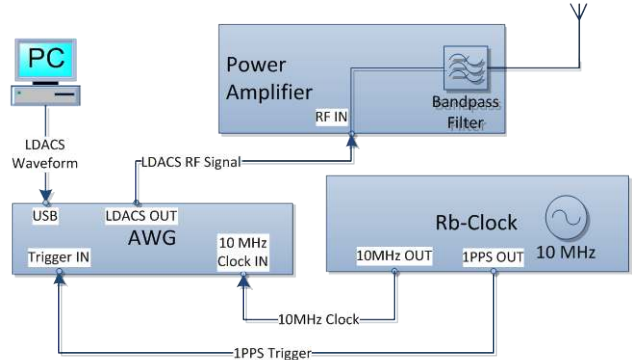

**Figure 3. Block Diagram of the Transmitting Part of the Ground Station**

The use of the AWGs in the setup allows for a significant simplification of the transmitter design and synchronization, as the generators can be accurately clocked and triggered using rubidium atomic clocks at pre-determined time instances, which, as we will discuss later in the text, is crucial for a successful operation of the whole measurement setup. The output of the AWG is then applied directly to the power amplifier, which also performs necessary bandpass filtering to minimize out-of-band emissions.

## Airborne Infrastructure

The setup of the Airborne Station (AS) consists of 2 key components: pre-amplifier with the data recorder, which together constitute a universal receiver module, and a reference positioning system, whose goal is to provide validation data for assessing the accuracy and precision of the LDACS1-computed navigational data. The latter is realized using a PolaRx2e GPS receiver, manufactured by Septentrio [7]. Both LDACS1-based as well as GPS-based reference positions of the aircraft will be evaluated in post-processing. Thus, the airborne equipment is dimensioned only for recording the signals for further processing.

The pre-amplifier is needed to perform initial signal extraction and amplification, see Figure 4. In addition to a Low Noise Amplifier (LNA), the preamplifier also includes two bandpass filters, whose role is signal extraction, as well as attenuation of possible out-of-band interferences. The role of the first filter is to protect the LNA. This filter has relatively low passband attenuation, yet it is not very steep. The second filter has a much steeper transition bands, which improves interference rejection.

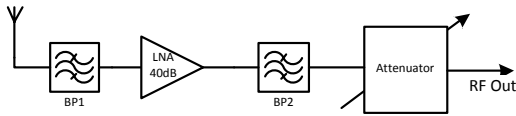

**Figure 4. Block Diagram of the Preamplifier**

Specifically, one of the strongest interferences that we expect will come from the on-board DME transmitter, as well as from the TACAN station [4] located in Erding, which is only 60km away from station A. The TACAN transmitter operates at 962MHz, which is only 3MHz away from the LDACS1 frequency range used in the experiments. It should be mentioned, however, that a preliminary test flight has indicated a very low out-of-band radiation for this station. The on-board DME transmitter will operate in higher frequency bands; a large part of this interference will be sufficiently reduced by the receiving filters. However we expect to see some broadband noise generated by the on-board transmitter in the measurement bandwidth.

The pre-amplifier is also equipped with a programmable attenuator. The goal of the attenuator is to realize an Automatic Gain Control (AGC) feature. The AGC algorithm at the receiver can be easily realized based on the following assumptions: (i) the positions of the GSs are fixed and known and (ii) the receiver also knows its current position based on the GPS coordinates. Then, assuming the transmitting power for all stations is known and fixed, the level of the received signal from the stations can be approximated based on the free space propagation loss model. The gain is then adjusted so as to make sure that the weakest signal can be received.

The data recorder is realized using a configurable PXI platform from National Instruments [8]. The setup includes a vector signal analyzer NI

PXIe-5665, which is used to sample simultaneously the data from all 4 GSs, the timing modules NI PXIe-6674T and PXIe-6682H, which allows for an accurate data time stamping and synchronization, a storage module NI 8260, a digital oscilloscope module PXI-5142 for data calibration, and a PC controller NI PXIe-8133. The vector signal analyzer will sample the 965MHz-975MHz frequency range, which will include all 4 GS channels, and store the sampled data on a hard disc. In post-processing, individual channels will be extracted using digital down conversion. Following standard estimation techniques [9], the propagation delay between each station and the receiver, as well as the clock offset between the GSs and AS can be estimated. This will in turn allow for estimating the AS position given the known positions of the GSs by solving the navigation equation.

## Timing and Synchronization of the Stations

Synchronization plays a key role in achieving accurate position estimation results. Errors or uncertainties in the clock synchronization readily translate into the corresponding uncertainties and errors in the final position estimates. Thus, it is crucial to keep the timing errors as small as possible.

In order to reduce the timing errors it was decided to employ 10MHz rubidium frequency standards at all stations. For this purpose, we use the rubidium clock SRO-100, manufactured by [10]. The SRO-100 clock, in addition to the 10MHz clock signal, also outputs a 1-Pulse-Per-Second (1PPS) signal that is phase-locked to the clock signal. This 1PPS signal is used in the setup to trigger the AWG, see Figure 3. Thus, the LDACS1 signal is transmitted every second. As we will see later, the use of GPS time receivers will allow us to relate each transmission of the LDACS1 signal to the GPS second with high accuracy, thus ensuring the synchrony of the GSs. The AS likewise uses a rubidium standard to clock the data recording hardware. Yet the receiver makes use of a simple Low Profile Frequency Rubidium Standard (LPFRS), also manufactured by Spectratime. The latter model does not have 1PPS output signal, which is not required at the receiver.

Although atomic clocks provide a very stable reference frequency, they alone are not sufficient for ensuring that GSs transmit the signals synchronously. Specifically, each clock has a different phase with respect to each other. This phase is unknown unless all clocks are present in one location and can be compared against some master clock. Unfortunately, having all clocks in the same location is only possible in a laboratory setting. In normal operation the stations will be geographically distributed. In order to address this challenge we make use of the GPS timing signals, as outlined below.

### GPS-Based Station Synchronization

One possibility to synchronize the stations is to exploit the timing signals transmitted by GPS satellites. This timing information can be used to monitor the drift of the atomic clock on the ground against the GPS clock. The corresponding

measurement setup is shown in Figure 5. Observe that the rubidium clock is used as a frequency source for the GPS time receiver (we use Septentrio PolaRx2 GPS time receiver), as well as for the AWG. The 1PPS signal is used to trigger the signal generation at the AWG every second; the GPS time receiver uses the 1PPS signal to compute the exact time reference. The data outputted by the GPS time receiver can be logged and, provided the GPS receiver is calibrated, can be used to compute in post-processing the atomic clock drift with respect to the GPS time.

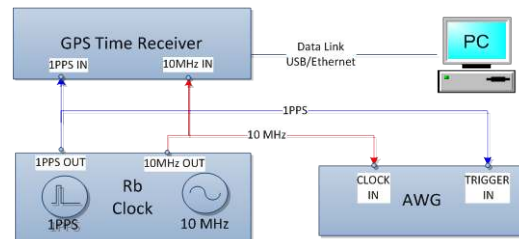

**Figure 5. Clock Monitoring with a GPS Time Receiver**

Note that this allows for an alignment of all 1PPS signals to a common time reference, i.e., GPS time in our case, thus achieving the synchronization of all stations. Such setting allows a synchronization accuracy of several nanoseconds.

Although this setup is relatively simple, it has several caveats. First, the GPS receiver of all stations must be carefully calibrated. Also, the synchronization can be achieved only in post-processing. However, one of the most critical points in the setup is the dependence on the GPS during the signal generation. In other words, if the GPS is not available, e.g., due to the interference from the co-located transmitting antenna, the atomic clock observation will not be possible. In order to avoid the latter scenario, several precautions are considered. First, the power amplifier in Figure 3 is adjusted so as to have a cut-off frequency at 1GHz. Additionally, the transmit filter has been designed such as to minimize the out-of-band emissions at the GPS frequencies.

Let us also stress that in the operation regime LDACS stations will not rely on GPS for accurate station synchronization. Instead, other synchronization strategies will be employed, e.g.,

SAT-based time reference in a different frequency band or dedicated ground links. The decision to use GPS for station synchronization has been made to merely simplify the design of the GSs.

## Calibration of the Measurement Setup

In order to achieve accurate synchronization of all stations, it is also necessary to take propagation delays caused by the components of the GSs into account. This requires calibration of the measurement setup.

Consider the timing scheme shown in Figure 6. Essentially, the setup calibration implies measuring the propagation delays  $\tau_a$ ,  $\tau_b$ ,  $\tau_c$ , and  $\tau_d$  caused by transmitting hardware, as well as the delay  $\tau_{AS}$ , which accounts for the hardware delay of the receiver. These delays are needed to properly compensate the estimated propagation delays  $\tau_1$ ,  $\tau_2$ ,  $\tau_3$ , and  $\tau_4$  in order to be able to compute the true range between the aircraft and the GSs.

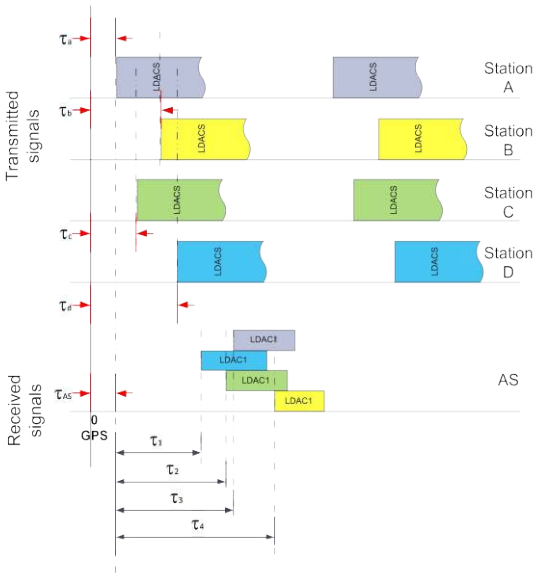

**Figure 6. Calibration of the Measurement Setup**

The calibration delays can be estimated in a laboratory by transmitting the signal over a medium with a known dispersion properties, i.e., over a cable, as shown in Figure 7. First, the atomic clocks of all stations are manually synchronized using the PXI oscilloscope module from National Instruments. Once the clocks are phase-aligned, the transmitters

are connected through a cable to a power combiner, attenuator, and the transmitter. Then, the Data recorder starts the AWGs by sending simultaneously the trigger signals and beginning the acquisition. This provides a common absolute time reference for all stations. The formalism behind such calibration approach is quite simple.

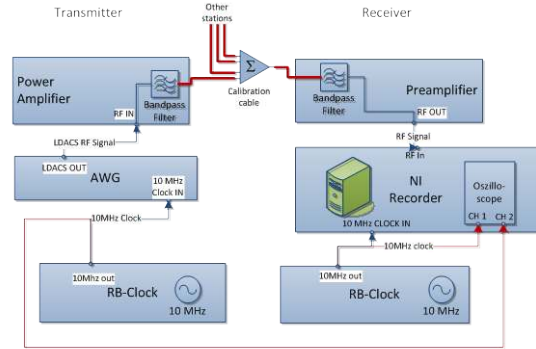

**Figure 7. Calibration Setup for a Single Station**

Each AWG generates a digital LDACS1 signal  $S(e^{j\omega})$  saved in its memory and modulates it to the corresponding carrier frequency, resulting in an analog transmitted signal  $S(j\omega)$ . This signal is then further processed by the transmitter hardware with the frequency response  $T(j\omega)$ ; it is this signal that is applied to the transmitting antenna. Similarly, the frequency response of the receiver hardware can be described by the transfer function  $R(j\omega)$ . Assuming linearity of the equipment, the calibration signal  $C(j\omega)$  at the input of the A/D converter can be represented as

$$C(j\omega) = S(j\omega) T(j\omega) R(j\omega).$$

The sampled version  $C(e^{j\omega})$  of the calibration signal is then stored on a computer. During the actual measurement any additional delays that come on top of the delays already included in the calibration data must be due to the propagation delay between the transmitter and receiver. In other words, in the operational regime the signal between the transmitter and receiver will undergo a linear transformation by the channel with the time-discrete frequency response  $H(e^{j\omega})$ . A model of the received signal  $Y(e^{j\omega})$  can then be rewritten as

$$Y(e^{j\omega}) = S(e^{j\omega}) T(e^{j\omega}) H(e^{j\omega}) R(e^{j\omega}) = C(e^{j\omega}) H(e^{j\omega}).$$

Naturally, the estimation of the propagation channel  $H(e^{j\theta})$  between the transmitter and receiver can be computed as

$$H(e^{j\theta}) = Y(e^{j\theta}) / C(e^{j\theta}).$$

The phase of  $H(e^{j\theta})$  determines the propagation delay between the transmitter and receiver. Note that the phase of the calibration data  $C(e^{j\theta})$  readily accounts for all the delays in the transmission path, including non-flatness of the phase of the transmitted signal, clock discrepancies and delays of analog filters that, in general, do not have a constant group delay, etc.

With an exception of station A, the calibration data for the stations B, C, and D, will be estimated only in the laboratory. For station A, the calibration will also be performed in-field, specifically immediately before and after each flight. This is possible as this station is situated at the German Aerospace Center research site Operpfaffenhofen, where the test airplane will take-off and land. This allows taking calibration data two times: first, at the beginning of the flight, also manually aligning the clock at the AS to the clock at station A, and at the end of the flight. The goal of the last measurement is to measure the drift of the clock at the AS with respect to the clock in station A. Such calibration and clock alignment can be used to validate the quality of the GPS-based synchronization using an alternative strategy, as well as correct for the clock offset at the AS in case when not all of the GSs are received due to SNR fluctuations, or shadowing. In the latter case the estimation of both 3D position and timing offset of the AS clock would be impossible. Note, however, that this procedure implicitly assumes a liner clock drift, which is only an approximation of the actual clock dynamics.

### LDACS1 Signal Structure

In the considered measurement setup the AWG will be programmed to generate and modulate LDACS1 signals. The structure of the transmitted LDACS1 signal is shown in Figure 8. Essentially, it follows the LDACS1 forward link data structure, as outlined in [3]. As mentioned previously, the AWG will be triggered every GPS second. After the trigger is received, the AWG will generate a sequence of 4 superframes, each having duration of 240ms. Note

that for the chosen geographical distribution of the stations the 40ms interval between consecutive transmissions is sufficient to avoid any intersymbol interference. Following the LDACS1 signal specification, each superframe will include a broadcast frame, and four data carrying multiframes. The time-frequency structure of the broadcast frame is shown in Figure 9; the structure of the data and control information frames is shown in Figure 10.

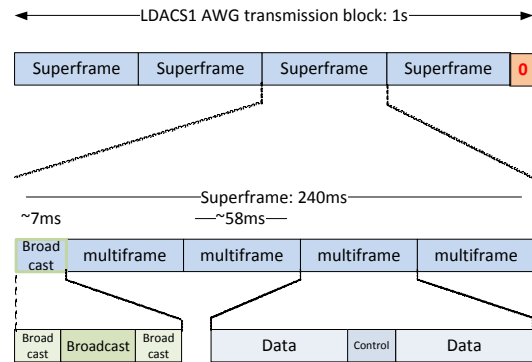

Figure 8. Structure of the Transmitted LDACS1 Signal

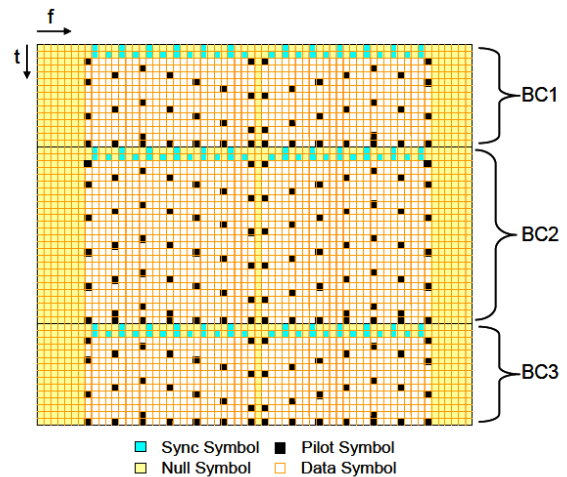
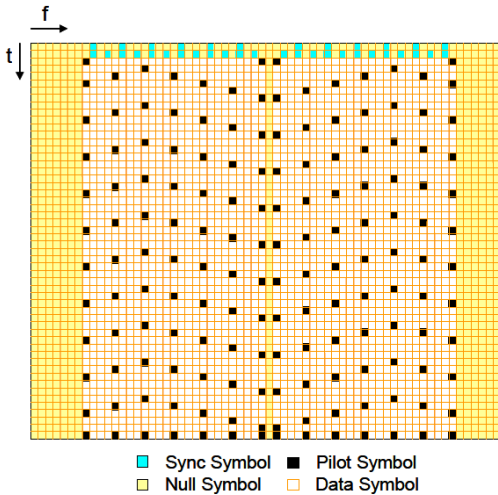

Figure 9. Structure of the Broadcast Frame



**Figure 10. Structure of the Data/Control Frame**

Note that not only synchronization symbols at the beginning of each frame can be used for ranging. Provided the data is successfully received and decoded, which can be verified at higher protocol layers, the data carrying symbols can be exploited for ranging as well. In our setup we will fill the data-carrying symbols with specially designed symbols that have a low peak-to-average power ratio (PAPR) of approx. 3dB.

## Processing of the Measurement Data

As already mentioned, the data recorded by the AS will be only minimally processed during the measurement. The final position estimation, clock synchronization and computation of the reference positions will take place in post-processing.

The data recorded by the NI data recorder will be processed in Matlab. The processing will include digital down conversion and extraction of the 4 channels for the GSs. Then, correlation analysis will be applied to estimate the propagation time between the transmitter and receiver. This will require accurate clock synchronization and the use of the calibration data to compensate for the hardware delay of the transmitter and receiver systems.



The positioning results obtained based on the LDACS1 signal will be compared to the GPS-based position estimates, recorded by GPS receiver on board the AS. In post-processing the data recorded by the GPS receiver will be corrected using a GPS ground reference station to obtain accurate position estimates. As both LDACS1-based estimates and GPS-based estimates will be time-stamped with the same GPS time mark, it will be possible to compare both estimates, thus assessing the performance of the LDACS1 proposal for APNT.

## Summary

In this paper a short summary of the flight measurement campaign, aimed at validation and test of the LDACS1-based proposal for the APNT service has been described. The measurement campaign, initiated by the German Aerospace Center, will implement the core structure of the LDACS1 system with four ground stations and an airborne receiver. The flight campaign is scheduled to start in November 2012. The results of the campaign will be reported at the next DASC conference in 2013.

## References

- [1] NextGEN. Federal Aviation Administration. <http://www.faa.gov/nextgen/>.
- [2] SESAR Joint Undertaking. <http://www.sesarju.eu/>.
- [3] LDACS1 Specification Proposal. <http://www.eurocontrol.int/communications/gallery/c>
- [4] M. Kayton and W.R. Fried, editors. *Avionics Navigation Systems*. John Wiley & Sons, Inc., 1969.
- [5] Michael Schnell, Ulrich Epple, and Felix Hoffmann. Using the future L-band communication system for navigation. In *Integrated Communications, Navigation, and Surveillance (ICNS'11)*, Herndon, VA, USA, 10-12 May 2011.
- [6] Rohde & Schwarz AG. <http://www.rohdeschwarz.de/>.
- [7] Septentrio Satellite Navigation. <http://www.septentrio.com/>.
- [8] National Instruments. <http://www.ni.com>.
- [9] Steven M. Kay. *Fundamentals of Statistical Signal Processing: Estimation Theory*. Prentice Hall, 1993.
- [10] Spectratime. <http://www.spectratime.com>.

## Email Addresses

Dmitriy.Shutin@DLR.de

Nicolas.Schneckenburger@DLR.de

Michael.Schnell@DLR.de

*31st Digital Avionics Systems Conference*

*October 14-18, 2012*