



LUND UNIVERSITY

Lean burn versus stoichiometric operation with EGR and 3-way catalyst of an engine fueled with natural gas and hydrogen enriched natural gas

Saanum, Inge; Bysveen, Marie; Tunestål, Per; Johansson, Bengt

Published in:
SAE Transactions Journal of Engines

DOI:
[10.4271/2007-01-0015](https://doi.org/10.4271/2007-01-0015)

2007

[Link to publication](#)

Citation for published version (APA):
Saanum, I., Bysveen, M., Tunestål, P., & Johansson, B. (2007). Lean burn versus stoichiometric operation with EGR and 3-way catalyst of an engine fueled with natural gas and hydrogen enriched natural gas. In *SAE Transactions Journal of Engines* (3 ed., Vol. 116). [2007-01-0015] Society of Automotive Engineers. <https://doi.org/10.4271/2007-01-0015>

Total number of authors:
4

General rights

Unless other specific re-use rights are stated the following general rights apply:
Copyright and moral rights for the publications made accessible in the public portal are retained by the authors and/or other copyright owners and it is a condition of accessing publications that users recognise and abide by the legal requirements associated with these rights.

- Users may download and print one copy of any publication from the public portal for the purpose of private study or research.
- You may not further distribute the material or use it for any profit-making activity or commercial gain
- You may freely distribute the URL identifying the publication in the public portal

Read more about Creative commons licenses: <https://creativecommons.org/licenses/>

Take down policy

If you believe that this document breaches copyright please contact us providing details, and we will remove access to the work immediately and investigate your claim.

LUND UNIVERSITY

PO Box 117
221 00 Lund
+46 46-222 00 00

Lean burn versus stoichiometric operation with EGR and 3-way catalyst of an engine fueled with natural gas and hydrogen enriched natural gas

Inge Saanum, Marie Bysveen

Norwegian University of Science and Technology, NTNU, Norway

Per Tunestål, Bengt Johansson

Lund University, Sweden

Copyright © 2005 SAE International

ABSTRACT

Engine tests have been performed on a 9.6 liter spark-ignited engine fueled by natural gas and a mixture of 25/75 hydrogen/natural gas by volume. The scope of the work was to test two strategies for low emissions of harmful gases; lean burn operation and stoichiometric operation with EGR and a three-way catalyst. Most gas engines today, used in city buses, utilize the lean burn approach to achieve low NO_x formation and high thermal efficiency. However, the lean burn approach may not be sufficient for future emissions legislation. One way to improve the lean burn strategy is to add hydrogen to the fuel to increase the lean limit and thus reduce the NO_x formation without increasing the emissions of HC. Even so, the best commercially available technology for low emissions of NO_x, HC and CO today is stoichiometric operation with a three-way catalyst as used in passenger cars. The drawbacks of stoichiometric operation are low thermal efficiency because of the high pumping work, low possible compression ratio and large heat losses. The recirculation of exhaust gas is one way to reduce these drawbacks and achieve efficiencies that are not much lower than the lean burn technology. The experiments revealed that even with the 25 vol% hydrogen mixture, NO_x levels are much higher for the lean burn approach than that of the EGR and catalyst approach for this engine. However, a penalty in brake thermal efficiency has to be accepted for the EGR approach as the thermodynamic conditions are less ideal.

INTRODUCTION

In recent years, extensive research has been done to make spark-ignited engines fueled by natural gas more competitive to diesel engines. The focus has been on extending the lean limit of the combustion to increase efficiency and lower the NO_x emissions. By increasing the excess air there is a decrease in both the peak temperatures and the formation of nitrous oxides. At the

same time, lean combustion makes it possible to achieve high efficiency at low and medium loads as less throttling results in a lower rate of pump work. The reduced peak temperature also leads to less heat loss which increases the efficiency. The knock tendency is also reduced, resulting in a higher compression ratio and thus an increase in efficiency. However, there is a tradeoff between the formation of NO_x and unburnt hydrocarbons (HC) as the lower combustion temperature increases the emissions of HC. Hydrogen has proven to be a well-suited additive to extend the lean limit because of its high reactivity and laminar flame speed. Several research projects have found that the tradeoff situation is improved when a relatively small amount of hydrogen is introduced [3], [4]. When the amount of hydrogen addition is limited to about 20 vol%, problems such as backfire, uncontrolled ignition and low volumetric energy content are overcome.

However, even if high excess air ratio and low NO_x is possible with the addition of hydrogen, the engine cannot always run very lean. In real engine applications, like in a city bus engine, the load and speed are highly transient. In order to achieve driveability, the engine requires variation in the air/fuel ratio with less lean mixtures in some situations like acceleration and low engine speed. Also, limitations in the response time and the accuracy of the control system results in lower λ in some situations. Very high levels of NO_x can then be emitted as the engine can run close to the conditions where the maximum amount of NO_x is formed. The engine used in this work had a maximum NO_x formation level at around $\lambda = 1.2$.

Another way of dealing with NO_x emissions is catalytic conversion. The three-way catalyst has proven to be very efficient in reducing NO_x, HC and CO simultaneously in gasoline engines. The drawback is that the engine has to run close to the stoichiometric air/fuel ratio in order to make the catalytic NO_x reduction reactions occur, and this leads to low thermal efficiency.

But if the mixture is diluted by recirculated exhaust gas (EGR), similar advantages such as being diluted with air are achieved and the air/fuel ratio can remain stoichiometric. As with the lean limit for lean burn engines, there is a limit to how much recirculated exhaust gas the engine can tolerate before the combustion efficiency becomes poor and the cycle-to-cycle variations are severe. Introducing hydrogen to the fuel should also help to increase the achievable dilution level for an engine with EGR because of the high reactivity and high laminar flame speed.

Patrik Einewall et al. [1] at LTH in Sweden carried out experiments where lean burn operation was compared to stoichiometric operation with EGR and a three-way catalyst for a natural gas fueled engine. They found that stoichiometric operation with EGR and catalyst gave much lower NO_x and HC emissions (10-30 and 360-700 times lower, respectively) with only a slight decrease in brake efficiency compared to lean burn operation. The CO emissions however, were found to be about 10 times higher than for the EGR solution, but it should be noted that the λ control was not optimized for the use of a three-way catalyst.

Also at LTH, Per Tunestål et al. [4] performed engine experiments with natural gas/hydrogen mixtures where they tested two combustion chambers with different turbulence levels. They found that the addition of hydrogen resulted in an improvement in the tradeoff between NO_x and HC and achieved a reduction in both compared to pure natural gas. The effect of the addition of hydrogen was more pronounced for the low turbulence slow burning combustion chamber than for the high turbulence chamber.

Nellen et al. [5] developed a natural gas engine concept for stationary cogeneration applications. The engine was run on a stoichiometric mixture and was equipped with cooled EGR and a three-way catalyst. They demonstrated that high load (BMEP = 23 bar) and high fuel conversion efficiency (42%) is possible with very low emissions of NO_x, CO and THC.

Reppert et al. [6] converted a Mack E7G lean burn natural gas engine to stoichiometric operation with cooled EGR and a three-way catalyst. The emissions test, which measured according to the U.S. Federal Test Procedure, revealed 0.049 g/bhp-hr NO_x, 0.002 g/bhp-hr PM, 0.435 g/bhp-hr THC, 0.000 g/bhp-hr NMHC and 4.153 g/bhp-hr CO. The brake specific fuel consumption was 2% above the lean burn engine calibrated at 2 g/bhp-hr NO_x.

Thorough testing of hydrogen/natural gas mixtures as fuel was performed by Munshi et al. [3]. Dynamometer testing indicated a 50% reduction in NO_x for stationary operation and 56% reduction in a transient cycle when the engine was fueled with a 20 vol% hydrogen mixture compared to natural gas. The SunLine Transit Agency tested two buses with these lean burn engines. The buses completed 24 000-mile field trials successfully.

The scope of the present work is to investigate the effect of the addition of hydrogen when the engine is run stoichiometrically with EGR and a three-way catalyst. This work will compare the results with lean burn operation with respect to emissions of NO_x, HC and CO, and the effect on brake efficiency and cycle-to-cycle variations.

EXPERIMENTAL SETUP

The test engine was a Volvo TD100 bus engine that was designed to run on natural gas. The experiments were performed in the combustion engine laboratory at the University of Lund. The test rig is the same as used by [1].

Table 1 Engine specifications

Displacement volume/cyl	1600 ccm
Compression ratio	11.8:1
Rated power	184 kW (at 2000 rpm)
Maximum brake torque	1150 Nm (at 1150 rpm)
Bore	120.65 mm
Stroke	140 mm
Ignition sequence	1-5-3-6-2-4

The original single point gas injection system has been replaced by a port injection system with individual injectors for each cylinder. The gas supply pressure is 4.6 bar and in order to cover the whole load range, two injectors were mounted per cylinder. When running the engine on natural gas, the gas was supplied from the gas system in the building, but the 25 vol% hydrogen mixture was stored in a gas bottle battery. The original engine control system has been replaced by a system delivered by MECEL. It consists of six cylinder control modules (CCM) communicating with one control PC. This makes it possible to control the gas injection and ignition individually for the six cylinders. A crank angle encoder from Leine & Linde gives signals every 0.2 CAD. This passes on signals to the CCMs about the engine speed and piston position, ensuring correct injection and ignition timing. A closed loop lambda control system controls the air/fuel ratio that can be set from the computer. The EGR system is a long root, cooled system. The recycled exhaust gas is cooled in a water cooled heat exchanger before being introduced to the inlet air before the turbocharger at about 60 C. The amount of EGR is adjusted by a butterfly valve steered from the control computer. When high amounts of EGR are introduced, a valve in the exhaust outlet had to be throttled back to increase the exhaust pressure. Condensed water vapor from the EGR is removed by a water drain at the bottom of the intercooler and a water droplet trap mounted before the inlet manifold.

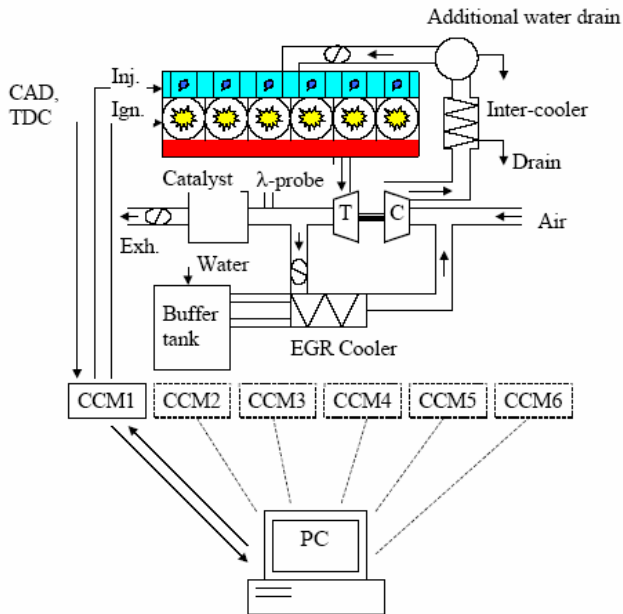

Figure 1 Engine

The emissions are measured by a Pierburg AMA 2000 emission system consisting of a heated flame ionization detector (HFID/FID) for hydrocarbon measurement, a chemiluminescence detector (HCLD/CLD) for NO_x measurement, a paramagnetic detector (PMD) for O₂ measurement and four non-dispersive infrared detectors for CO and CO₂ measurement at high and low ranges. Thermocouples are mounted in the exhaust manifold for the individual measurement of each cylinder, the inlet and outlet of the EGR cooler, in the air stream before the intercooler and after the throttle. Also, the oil and cooling water were monitored.

The cylinder pressure was measured in each cylinder by six Kistler 7061 piezoelectric pressure transducers and a charge amplifier, Kistler 5017A. The signals were processed in two Datel PCI-416 boards in a computer for online pressure measurements. The pressure recording system was also connected to the Leine & Linde crank angle encoder giving the temporal resolution of the pressure recordings to 0.2 CAD. The pressure measurements were recorded and stored in a computer, with recordings for 300 cycles in each test.

A Bronkhorst F106A-HC thermal mass flowmeter was used to measure the gas flow. The meter was calibrated for natural gas and did not give the correct value when the 25 vol% hydrogen mixture was introduced. A correction factor was calculated based on equal volumetric efficiency corrected by the measured temperature and pressure after the throttle and analysis of the exhaust gas. This was done for all the tests, and a mean value of the correction factor was finally used

assuming a constant error percentage in the measured mass flow.

The engine was connected to a Schenk U2-30G water brake connected to the control computer for engine speed control and torque measurement. The torque had to be adjusted manually by controlling the throttle.

The emission data, temperatures, torque and engine speed were collected by a HP 34970A data acquisition unit and stored in a computer.

EXPERIMENTS

The scope of the experiments was to see the effect of the addition of hydrogen when using two different engine operation approaches, the lean burn and the EGR for stoichiometric approach. First the engine was run on natural gas for reference. When testing the lean burn approach, the engine was first run at $\lambda = 1$, then λ was increased in steps of 0.1 until the lean limit was reached. The lean limit was defined as the point where the COV in IMEPn exceeded 10% for one cylinder. This was done under five different loads; 2, 7, 10, 12 and 14 bar BMEP. The ignition timing was held at MBT and the engine speed was 1200 rpm for every test. The EGR tests were done in a similar way, increasing the amount of EGR in steps of 5%. The amount of EGR was calculated according to;

$$\% EGR = \frac{CO_{2\text{Inlet}}}{CO_{2\text{Exhaust}}} \cdot 100$$

where the CO_{2 Inlet} is the volumetric concentration of CO₂ in the air+gas+EGR mixture. The CO₂ concentration was measured in the inlet stream before the injectors, but the results were adjusted for the amount of gas injected. The same procedure was used when testing the 25 vol% hydrogen mixture.

RESULTS

EMISSIONS BEFORE CATALYST

Because of the high laminar flame speed and low minimum ignition energy of hydrogen, it was expected to be able to increase the amount of excess air and the amount of EGR without increasing the emissions of HC and CO when using 25% hydrogen mixture. The experiments show the ability to increase lambda when the hydrogen mixture is used, but the possibility to increase the amount of EGR is not proven. This is associated with problems of water droplet entrainment in the inlet air with higher amounts of EGR. The water vapor from the recirculated exhaust condensed in the intercooler although it was supposed to be removed by the water drain at the bottom of the intercooler and by the extra water droplet trap mounted after the

intercooler. This was not sufficient as misfire occurred in the cylinder where the droplets probably ended up. The problem was most evident when the hydrogen mixture was used because of the greater amount of water in the exhaust gas.

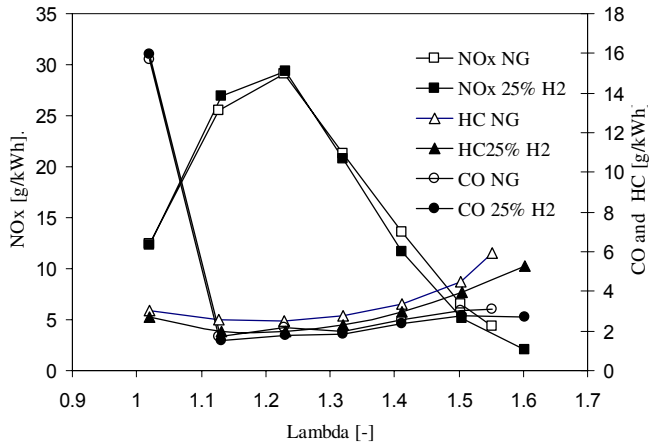

Figure 2 NO_x, HC and CO emissions before catalyst, lean burn at 10 bar BMEP

Figure 2 shows the emissions of NO_x, HC and CO at a load of 10 bar BMEP as a function of excess air ratio, λ . From $\lambda = 1.0$, the NO_x emissions increase by λ because of the amount of oxygen being available. The maximum NO_x emission is reached at around $\lambda = 1.2$, thereafter it decreases as the combustion temperature falls. The lean limit was defined as the point where the coefficient of variance in IMEP_n exceeded 10% in one cylinder. At the leanest points, it can be seen that the NO_x emissions are markedly lower for the 25 vol% hydrogen mixture, and at the same time the CO and HC is kept the same or even lower compared to the natural gas case.

NO_x emissions

Figure 3 and Figure 5 show the NO_x emissions as a function of the excess air ratio and the degree of EGR dilution respectively. The lean limit for the 12 bar BMEP was not reached because the load could not be maintained at higher λ . At the highest λ , the throttle was fully open. Figure 4 only shows the two loads that successfully reached the lean limit. Even though more tests should be run under in lean conditions to have a better statistical basis and a more accurately quantified lean limit, the results clearly indicate the NO_x reduction potential as a result of adding hydrogen.

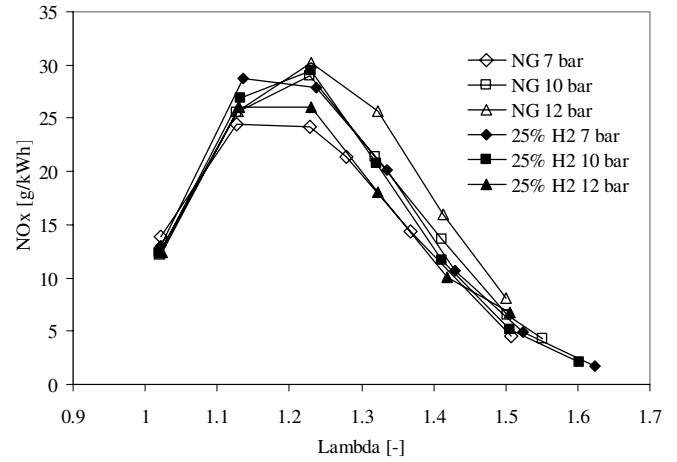

Figure 3 NO_x emissions before catalyst, lean burn

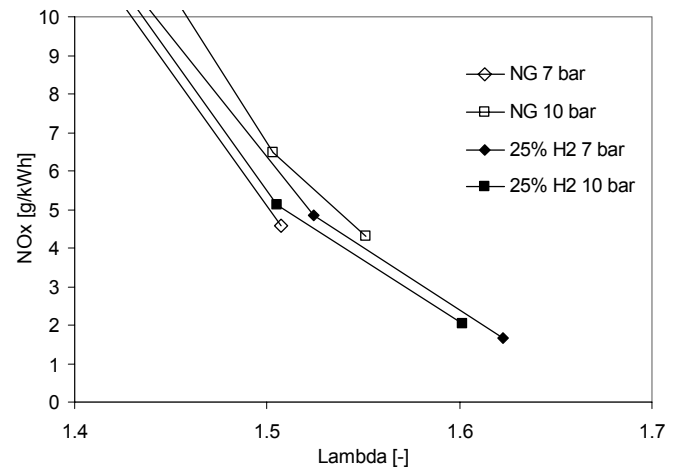

Figure 4 NO_x emissions before catalyst, lean burn, zoomed up

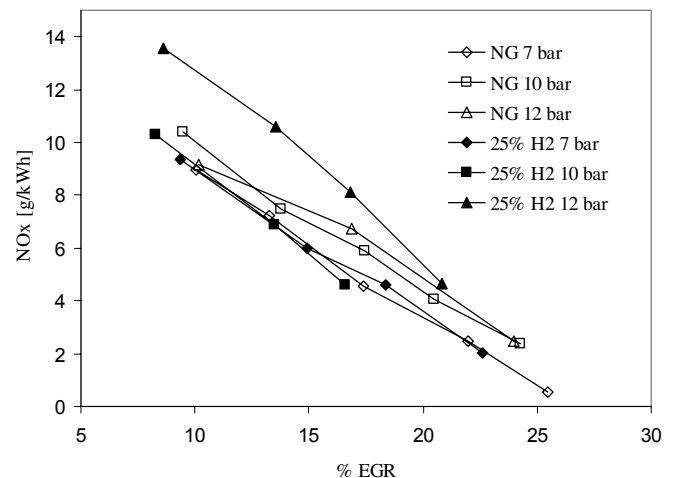

Figure 5 NO_x emissions before catalyst, EGR

The EGR reduces the NO_x emissions efficiently with a near linear decrease in the amount of EGR. At the same time, the level of dilution (i.e. with the same volume flow of EGR as the volume of excess air for the same load), in the EGR case results in much lower NO_x. The available oxygen is much lower for the EGR cases as the mixture is kept near stoichiometric conditions, and this results in less NO_x formation. Higher NO_x emissions were expected for the hydrogen mixture as the adiabatic flame temperature is higher for hydrogen than for natural gas. No such consistent relation between NO_x and hydrogen content is observed. This may have to do with the strategy of ignition timing adjustment. The ignition timing was adjusted so the maximum pressure was obtained at 12 CAD ATDC, as earlier work found this timing to be the MBT timing [1]. This adjustment was done manually from the control computer, observing the real-time pressure recordings and setting the timing where the average maximum pressure of the six cylinders was at about 12 CAD ATDC. This is of course a source of human error, and as the NO_x formation is known to have an exponential dependence on the temperature, it is probable that it is very sensitive to the ignition timing as this greatly influences the maximum pressure and hence the temperature. Earlier experiments performed with the same engine show the possibility of really influencing the NO_x formation by ignition timing without having too much influence on the brake efficiency [1]. It may be argued that the ignition timing should be adjusted to minimize NO_x formation, but for a lean burn vs. EGR comparison the MBT ignition timing was considered most appropriate. If minimal NO_x ignition timing is to be employed, the question arises about how high a penalty in brake efficiency should be tolerated. However, prior research indicates that the addition of hydrogen makes the MBT less sensitive to ignition timing [2].

HC emissions

The emissions of unburnt hydrocarbons have the opposite trend to NO_x in the lean burn cases. Emissions decrease with lambda as the available oxygen for oxidation increases, but start to increase at around lambda 1.2 as the lower flame temperature reduces the combustion efficiency.

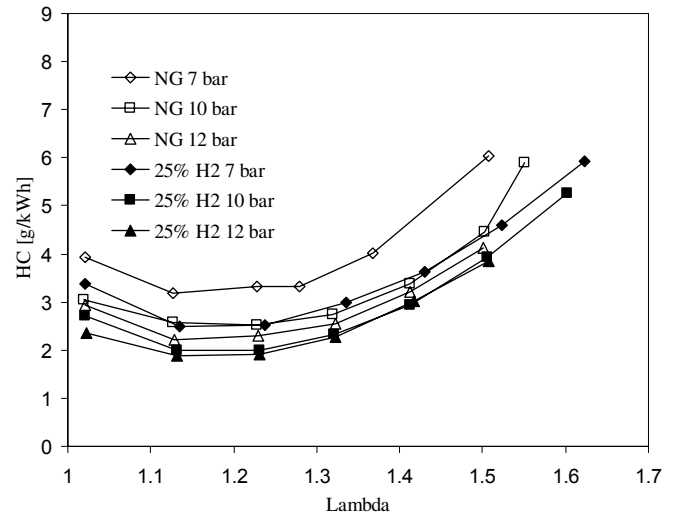

Figure 6 HC emissions before catalyst, lean burn

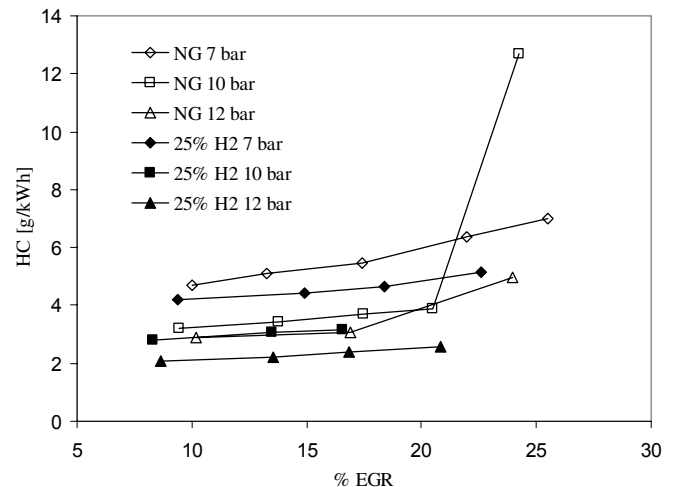

Figure 7 HC emissions before catalyst, EGR

Because of the above-mentioned problems with water entrainment, the EGR levels did not reach the “natural” dilution limit of stable combustion. The high HC emission for natural gas at 10 bar BMEP is clearly caused by misfire due to water entrainment as the COV in IMEP_n is over 50% in the cylinder that most probably received the water droplets. In all load cases the HC emissions are less for the hydrogen enriched gas. Part of the explanation is that there are fewer hydrocarbons in the fuel, but as 25% hydrogen by volume only represents about 8.4% by energy and 3.7% by mass, the reduction is more than the reduction in hydrocarbon in the fuel. The trend is shown for both the lean burn and the EGR cases. Figure 8 shows the HC emissions as mass HC per mass of natural gas supplied. This clearly shows that the addition of hydrogen improves the HC oxidation.

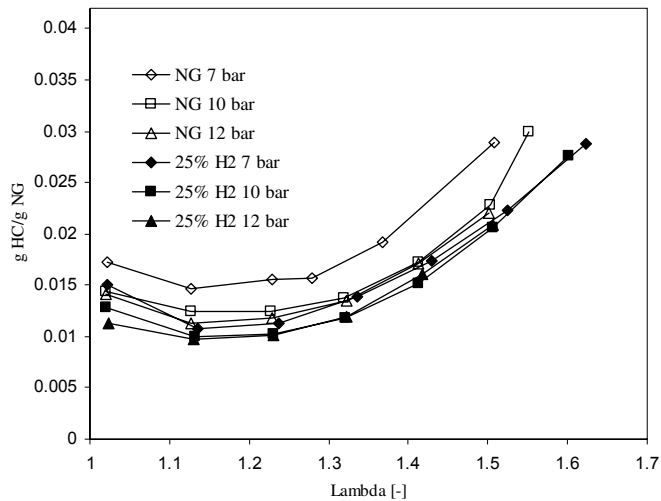

Figure 8 HC emissions before catalyst presented as mass HC per mass NG supplied

CO emissions

The CO emissions are very high for lambda 1 and the EGR cases (operation at lambda 1). This is because the lambda was set to slightly rich for the catalyst to work. In gasoline engines where the three-way catalyst is applied, the λ oscillates between slightly rich and slightly lean to create both oxidizing and reducing conditions in the catalyst. The lambda control system used in these experiments did not oscillate. To be able to reduce NOx, the lambda had to be set to slightly rich and as the CO emissions are very sensitive to lambda at this point, rather large emissions were formed.

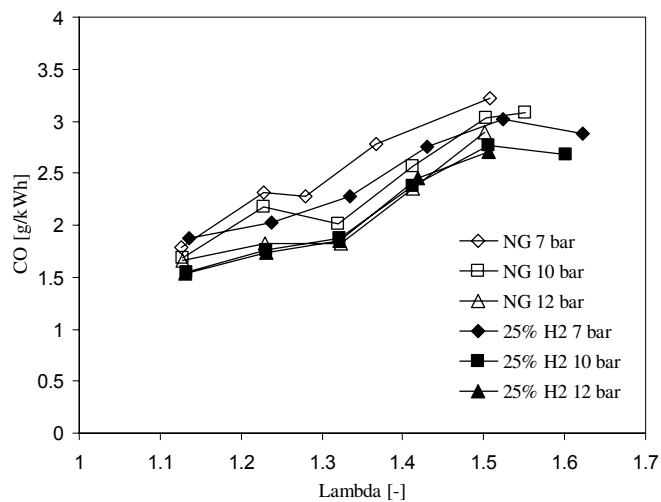

Figure 9 CO emissions before catalyst, lean burn

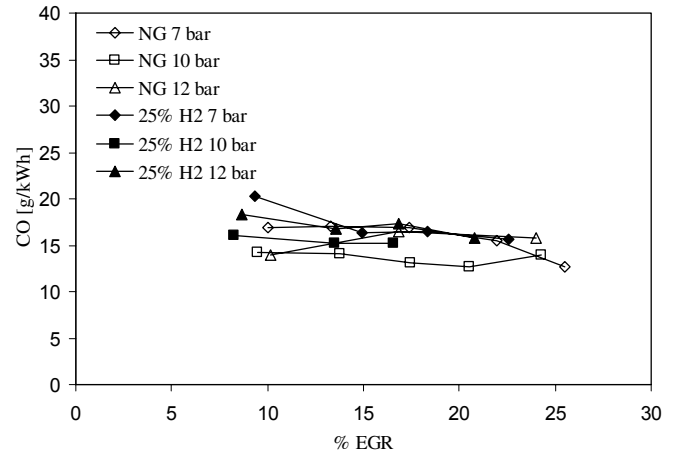

Figure 10 CO emissions before catalyst, EGR

No effect of hydrogen can be seen in the CO emissions for the EGR cases, but a decrease in CO is observed for the lean burn cases at constant load.

EMISSIONS AFTER CATALYST

The real advantage with EGR running with stoichiometric mixtures is that the three-way catalyst can be applied. Figure 11, Figure 12 and Figure 13 show the emissions of NO_x, HC and CO after the catalyst.

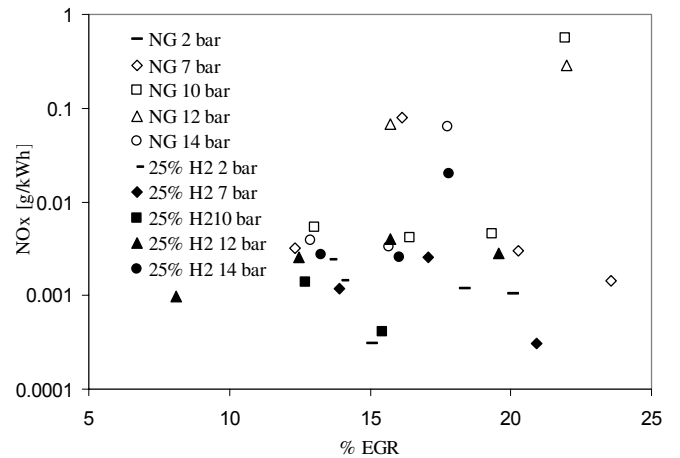

Figure 11 NOx emissions after catalyst, EGR

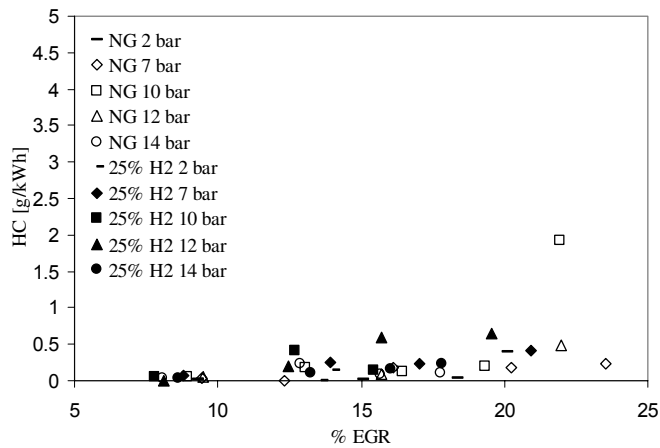

Figure 12 HC emissions after catalyst, EGR

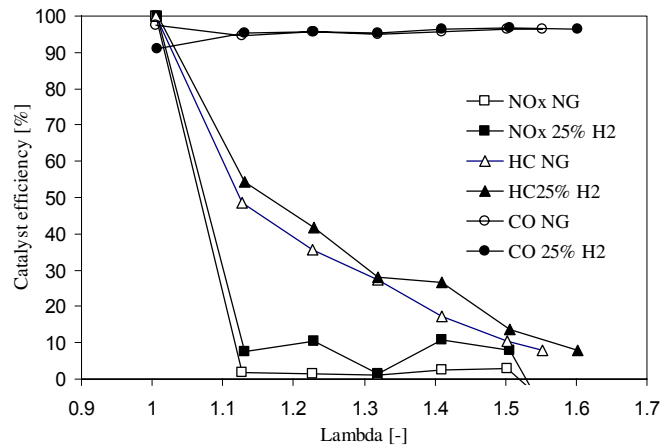

Figure 14 Catalyst efficiency for NOx, HC and CO reduction, lean burn at 10 bar BMEP

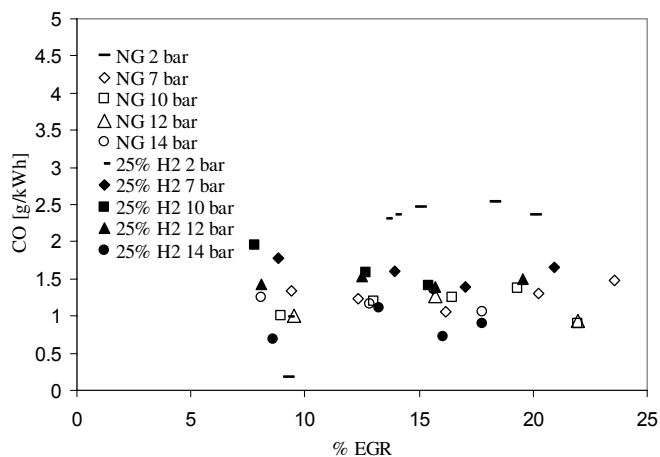

Figure 13 CO emissions after catalyst, EGR

Figure 14 shows how the three-way catalyst operates. The NOx reduction only functions near lambda 1. At higher lambdas the NOx reduction is practically zero. The non-zero value is probably due to natural variation as the NO_x emissions before and after the catalyst are not measured simultaneously. In this case the exhaust sample line is switched to collect sample gas before and after the catalyst. The HC emission is also poorly reduced at higher lambda, but a catalyst designed to operate under lean conditions would probably be able to reduce HC more efficiently. The CO is efficiently reduced over the whole lambda spectrum.

As mentioned above, the catalyst efficiency is very sensitive to lambda as the lambda control system is not an oscillating one. The lambda was adjusted to have a good reduction of NO_x and HC, but then some CO emissions had to be tolerated. Still, the CO emissions are for most cases lower than the CO emissions for the lean burn cases before the catalyst. The NO_x and HC emissions are very low compared to the lean burn cases at all loads, even though the catalyst efficiency is poor at some points where lambda has floated a bit off the set point. This would probably be avoided if the engine had an oscillating lambda control system.

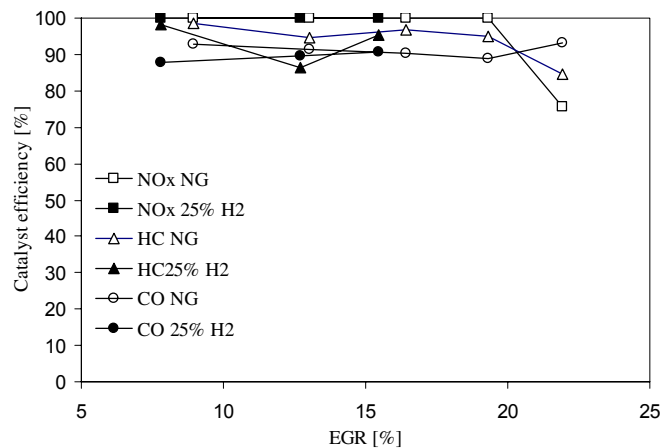

Figure 15 Catalyst efficiency for NOx, HC and CO reduction, EGR at 10 bar BMEP

Figure 15 illustrates that the three-way catalyst is able to reduce CO, HC and NO_x efficiently when the engine is operated at lambda 1 with EGR. An oscillating lambda control system may result in an even better reduction.

The results show that it should be possible to meet Euro 5 emission legislation with the stoichiometric + EGR and three-way catalyst approach both for natural gas and the 25 vol% hydrogen mixture. The emission limits for the Euro 5 transient cycle are 2 g/kWh NO_x, 1.65 g/kWh THC and 4 g/kWh CO. For this engine, the lean burn approach will not be able to meet Euro 5, even when using the 25 vol% hydrogen mixture. Even if the NO_x was kept under 2 g/kWh, the HC emissions are far too high without after-treatment. It should be noted that the Volvo engine used in these tests is not the cutting edge in gas engine technology. The combustion chamber, called "Turbine" cf. [4], is a rather slow burning low turbulence chamber.

EFFICIENCY

Figure 16 shows the maximum brake thermal efficiency under different loads. The 25% hydrogen mixture results in higher thermal efficiency for both the lean burn and the EGR cases.

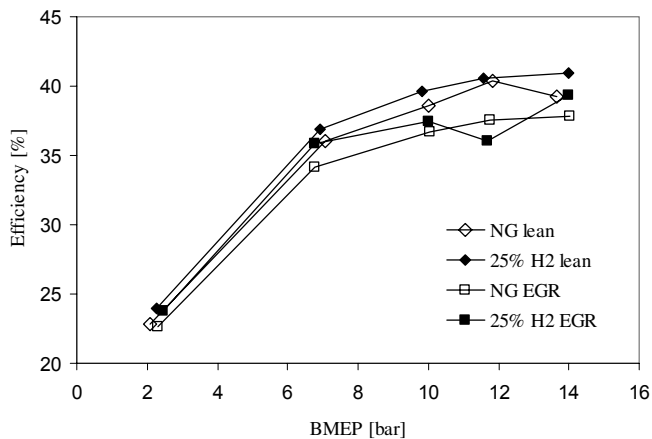

Figure 16 Maximum brake thermal efficiency, lean burn at 10 bar BMEP

The efficiency is calculated according to:

$$\eta = \frac{P}{m_f LHV}$$

Figure 17 and 18 show the brake thermal efficiency as a function of excess air ratio and amount of EGR respectively. The use of EGR results in a lower efficiency compared to lean burn. This may be explained by several effects. At low loads, the pumping work is high due to the throttling of the inlet flow. Because of the limited amount of oxygen available when running with EGR and a stoichiometric mixture, it is not possible to dilute the mixture as much as when running with lean burn. That is, the volume flow through the inlet is much higher at the maximum λ than the volume flow at the

maximum amount of EGR with the same BMEP. The pumping losses should thus be higher with EGR operation at low loads. At higher loads, the pumping work is of less significance. One negative effect of EGR is that the CO₂ and water vapor content decreases the ratio of specific heat, c_p/c_v , which influences the thermal efficiency. Also, the ratio of specific heat decreases with temperature. When running the engine with a high degree of air dilution, the effective c_p/c_v is higher than when running with EGR both because of the gas composition and the temperature. Another aspect is that the higher combustion temperature at EGR operation should result in more heat losses to the chamber walls. Also, the limited oxygen available leads to lower combustion efficiency. A penalty in efficiency must therefore be accepted when EGR is applied. However, a slightly increasing trend can be observed for the brake thermal efficiency with the amount of EGR for most cases. The maximum efficiency may not have been reached for all loads because of the water problem described above.

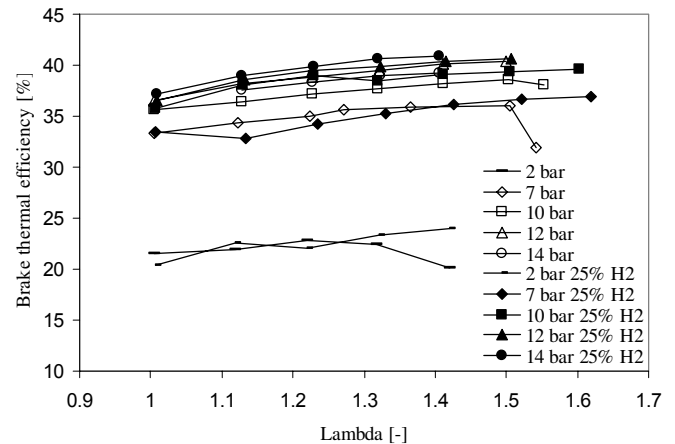

Figure 17 Brake thermal efficiency, lean

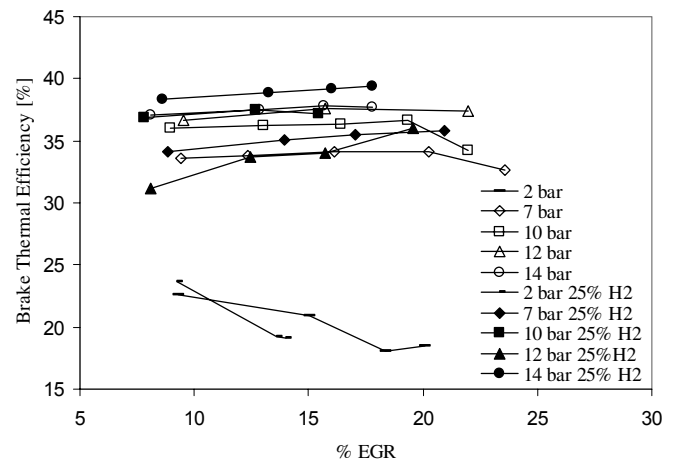

Figure 18 Brake thermal efficiency, EGR

At 2 bar BMEP with EGR, a decreasing trend is observed. This is because the combustion efficiency is reduced even for low EGR levels at this low load.

Energy analysis

Based on the measurements of gas flow into the engine, exhaust gas analysis, cylinder pressure recordings and brake power one can calculate the various energy losses. The pumping work can be found by the difference between $IMEP_{gross}$ and $IMEP_{net}$ as the MEPs represent energy normalized by the displacement volume. The difference between $IMEP_{net}$ and BMEP represents energy lost by friction. The losses from incomplete combustion can be found from the mass flow and lower heating value of the exhaust gases. The energy released in the combustion can then be found, and by subtracting the energy represented by $IMEP_{gross}$, we are left with the heat losses in the cylinder and to the exhaust gases. Figure 19 shows the energy losses presented as a percentage of the input fuel energy under different loads, with and without hydrogen addition and EGR. The tests that gave the highest brake efficiency were picked out for the calculations. Data for the tests are presented in Table 2.

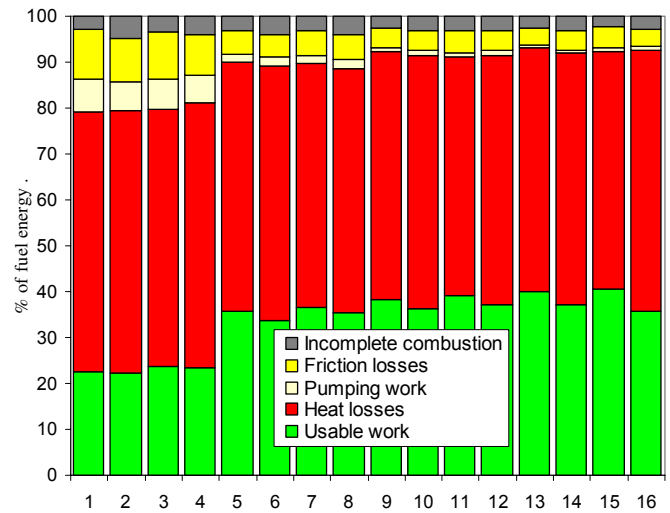

Figure 19 Energy losses for different loads at maximum brake efficiency

Table 2 Data for Figure 19

Column	Load (BMEP)	Fuel	Strategy	λ or %EGR
1	2.08	NG	Leanburn	1.22
2	2.30	NG	EGR	9.3
3	2.26	25%	Leanburn	1.42
4	2.46	25%	EGR	9.3
5	7.06	NG	Leanburn	1.51
6	6.90	NG	EGR	16.1
7	6.92	25%	Leanburn	1.62
8	6.76	25%	EGR	20.9
9	10.01	NG	Leanburn	1.50
10	10.05	NG	EGR	19.3
11	9.82	25%	Leanburn	1.60
12	10.03	25%	EGR	12.7
13	11.82	NG	Leanburn	1.50
14	11.78	NG	EGR	15.7
15	11.58	25%	Leanburn	1.51
16	11.69	25%	EGR	19.6

The lower brake thermal efficiency in the EGR cases can mainly be attributed to higher losses to incomplete combustion and higher heat losses to the exhaust and cylinder walls. The differences in pumping losses between the tests that have approximately the same loads are small. The first four columns that represent 2 bar BMEP have a rather large variety in load. This can explain the variation in friction losses.

COMBUSTION DURATION

The main combustion duration, 10-90% burnt, was calculated using a single zone heat release model developed at LTH. Figure 20 and Figure 21 show the main combustion duration for the lean burn and EGR cases.

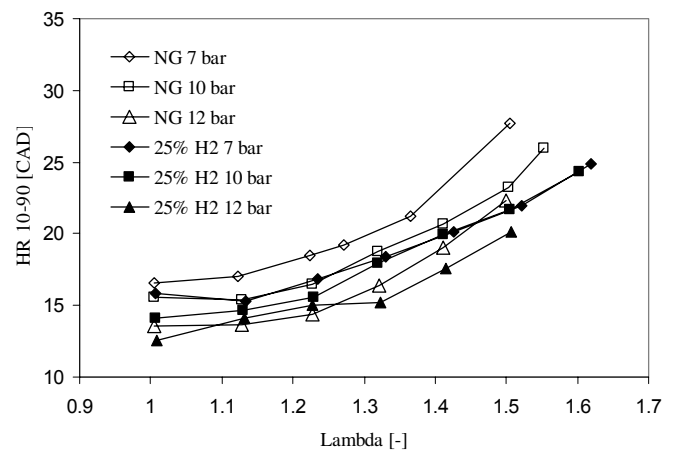

Figure 20 Main combustion duration (10-90% burnt), lean burn

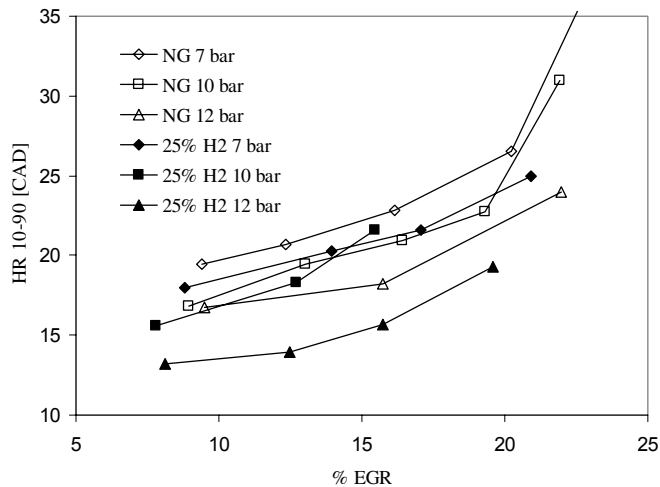

Figure 21 Main combustion duration (10-90% burnt), EGR

Generally, the 25 vol% hydrogen mixture had a shorter main combustion period for both the lean burn and the EGR cases. The shorter combustion period is the main reason for the increased efficiency observed with the hydrogen mixture. Shortening the combustion period makes the heat losses lower as the available time for heat transfer is reduced. Also, short combustion duration makes the cycle more like the thermodynamically ideal Otto cycle with an infinite short heat release time (or constant volume heat release). However, hydrogen addition should also shorten the quenching distance, having the opposite effect on the heat losses. The combustion duration is increased more rapidly with the degree of dilution when the mixture is diluted with EGR. When diluting the mixture with air as in the lean burn cases, the reaction rates will not slow down as much because the amount of oxygen available will increase. Unfortunately, the water droplet problem prevented us finding the effect of hydrogen at high EGR rates where the results would be most interesting.

STABILITY

The coefficient of variance of the net indicated mean effective pressure, COV IMEPn, is used as a measure of stability. In the lean burn experiments, the excess air ratio was increased until COV exceeded 10% in one cylinder. Figure 22 shows the COV averaged for the six cylinders for the tests loads of 7, 10 and 12 bar BMEP.

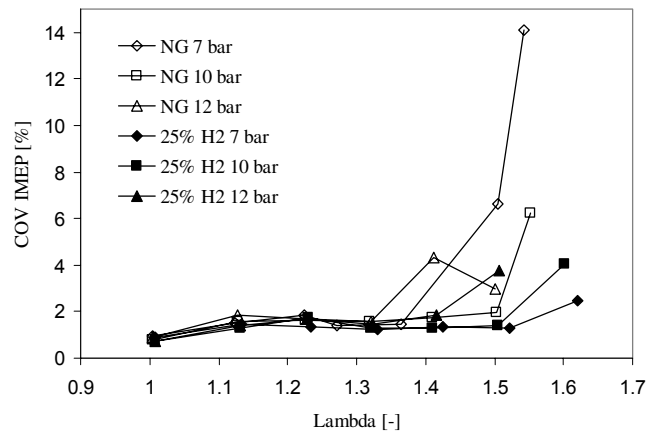

Figure 22 Coefficient of variance in IMEPn averaged for the six cylinders, lean burn

Although this is not consistent under all operational conditions, the addition of hydrogen seems to decrease the cycle-to-cycle variations. The increase in COV starts at a higher lambda for the 25 vol% hydrogen mixture.

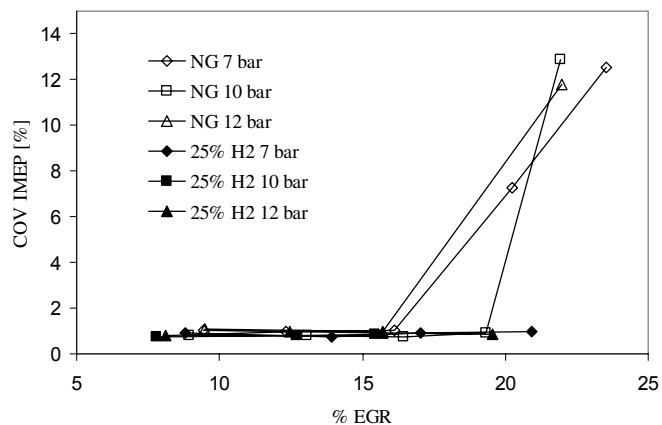

Figure 23 Coefficient of variance in IMEPn averaged for the six cylinders, EGR

Figure 23 shows the COV IMEPn for the EGR tests. The figure is somewhat misleading since it is only the natural gas tests that have a rise in COV. This is because the water problem made it impossible to run the engine at higher EGR levels with the addition of hydrogen and the "natural" increase in the COV therefore could not be recorded.

CONCLUSIONS

The addition of hydrogen to natural gas narrows down the difference between the emission levels for lean burn operation and stoichiometric operation with EGR and a three-way catalyst. However, it was not possible to get close to the very low NO_x and HC emissions found with EGR operation when using lean burn operation with this engine.

With this lambda control, the CO emissions for the EGR and catalyst case are in the same range or lower than the CO emissions of lean burn operation without catalyst both for natural gas and the 25 vol% hydrogen mixture. The CO and HC emissions for the lean burn cases are lower for the 25 vol% mixture at the same λ , also when corrected for the reduced HC content in the 25 vol% hydrogen mixture. But a large effect of hydrogen addition to CO and HC is first seen at excess air ratios higher than the lean limit of natural gas operation, where the 25 vol% mixture has still not crossed the defined lean limit.

The ability to reduce NO_x without increasing HC emissions by the addition of hydrogen to extend the lean limit is confirmed. No consistent trend can be seen in NO_x emissions at the same λ with or without hydrogen addition with the ignition timing strategy that was employed.

The maximum brake thermal efficiency is higher for lean burn operation than for EGR operation, both for natural gas and hydrogen enriched natural gas. Slightly higher efficiency for EGR operation may have been possible if the engine could handle higher EGR levels as an increasing trend with the EGR level is observed for most load cases. Higher efficiency is observed for the 25 vol% hydrogen mixture in most load cases, both for lean burn and EGR operation.

A better solution for water removal in the inlet stream is necessary to achieve higher EGR levels and determine the possibility to extend the limit of dilution by hydrogen enrichment. Also, more tests near the lean limit for lean burn operation would be beneficial to more accurately determine the lean limit and quantify the extension due to the addition of hydrogen at different loads.

ACKNOWLEDGMENTS

This work has been conducted at and financed by the Large Scale Facility (LSF) at Lund University. LSF is a European research infrastructure within European Commission's 5th Framework Programme. We would like to thank LSF and the staff at Lund University for organizing the stay and preparing and helping with the experimental work. Special thanks to Patrik Einewall whose help has been crucial.

REFERENCES

1. P. Einewall, P. Tunestål, B. Johansson, "Lean Burn Natural Gas vs. Stoichiometric Operation with EGR and a Three Way Catalyst", SAE 2005-01-0250
2. K. Collier, R. L. Hoekstra, N. Mulligan, C. Jones, D. Hahn, "Untreated Exhaust Emissions of a Hydrogen Enriched CNG Production Engine Conversion", SAE 960858
3. S.R. Munshi, C. Nedelcu, J. Harris, T. Edwards, J. Williams, F. Lynch, M. Frailey, G. Dixon, S. Wayne, R. Nine, "Hydrogen Blended Natural Gas Operation of a Heavy Duty Turbocharged Lean Burn Spark Ignition Engine" SAE 2004-01-2956
4. P. Tunestål, M. Christensen, P. Einewall, T. Andersson, B. Johansson, O. Jønsson, "Hydrogen Addition For Improved Lean Burn Capability of Slow and Fast Burning Natural Gas Combustion Chambers", SAE 2002-01-2686
5. C. Nellen, K. Boulouchos, "Natural Gas Engines for Cogeneration: Highest Efficiency and Near-Zero-Emissions through Turbocharging, EGR and 3-Way Catalytic Converter", SAE 2000-01-2825
6. T. Reppert, J. Chiu, "Heavy-Duty Waste Hauler with Chemically Correct Natural Gas Engine Diluted with EGR and Using a Three-Way Catalyst", Subcontract report NREL/SR-540-38222, September 2005

ABBREVIATIONS

BMEP	Brake Mean Effective Pressure
COV	Coefficient Of Variance (standard deviation / mean × 100)
EGR	Exhaust Gas Recirculation
IMEP _n	Net Indicated Mean Effective Pressure
<i>LHV</i>	Lower Heating Value [kW/kg]
MBT	Maximum Brake Torque
\dot{m}_f	Mass flow fuel [kg/s]
P	Power [kW]
λ	Excess air ratio (inverse of equivalence ratio)
η	Brake thermal efficiency