

N79-32211

(NASA-CR-159647) LEAN, PREMIXED,
PREVAPORIZED FUEL COMBUSTOR CONCEPTUAL
DESIGN STUDY Final Report (Pratt and
Whitney Aircraft Group) 63 P HC A04/MF A01
CSC L 21E G3/07

Unclas
35832



LEAN, PREMIXED, PREVAPORIZED
FUEL COMBUSTOR CONCEPTUAL DESIGN STUDY

-FINAL REPORT-

by A. J. Fiorentino, W. Greene, and J. Kim

United Technologies Corporation
Pratt & Whitney Aircraft Group
Commercial Products Division

prepared for

NATIONAL AERONAUTICS AND SPACE ADMINISTRATION

NASA Lewis Research Center
Contract NAS3-21256



| | | | |
|---|--|--|---------------------------------|
| 1. Report No NASA CR-159647 | 2. Government Accession No | 3. Recipient's Catalog No. | |
| 4. Title and Subtitle LEAN, PREMIXED, PREVAPORIZED FUEL COMBUSTOR CONCEPTUAL DESIGN STUDY | | 5. Report Date August, 1979 | 6. Performing Organization Code |
| | | 8. Performing Organization Report No PWA-5626-12 | 10. Work Unit No |
| 7. Author(s) A. J. Fiorentino, W. Greene, J. Kim | | 11. Contract or Grant No NAS3-21256 | |
| 9. Performing Organization Name and Address UNITED TECHNOLOGIES CORPORATION Pratt & Whitney Aircraft Group Commercial Products Division East Hartford, Connecticut 06108 | | 13. Type of Report and Period Covered Contractor Report | |
| | | 14. Sponsoring Agency Code | |
| 12. Sponsoring Agency Name and Address NATIONAL AERONAUTICS AND SPACE ADMINISTRATION Washington, D. C. 20546 | | 15. Supplementary Notes Project Manager, Edward J. Mularz, U.S. Army Research & Technology Laboratories (AVRADCOM), Propulsion Laboratory, NASA Lewis Research Center, Cleveland, Ohio | |
| 16. Abstract Four combustor concepts have been designed for the NASA/P&WA Energy Efficient Engine (E ³) in a 9-month conceptual design study program to identify and analytically evaluate lean, premixed prevaporized (LPP) combustors. The designs utilize variable geometry or other flow modulation techniques to control the equivalence ratio of the initial burning zone. Lean conditions are maintained at high power to control oxides of nitrogen while near stoichiometric conditions are maintained at low power for low CO and THC emissions. Each concept has been analyzed and ranked for its potential in meeting the goals of the program. Although the primary goal of the program is a low level of NO _x emissions ($\leq 3\text{g/kg}$ fuel) at stratospheric cruise conditions, both the ground level EPA emission standards and combustor performance and operational requirements typical of advanced subsonic aircraft engines are retained as goals as well. Based on the analytical projections made during this study, two of the concepts offer the potential of achieving the emission goals. However, the projected operational characteristics and reliability of any concept to perform satisfactorily over an entire aircraft flight envelope would require extensive experimental substantiation before engine adaptation can be considered. | | | |
| 17. Key Words (Suggested by Author(s)) Lean Premixed, Prevaporized Combustor, Variable Geometry, Energy Efficient Engine, Combustion, Emissions | | 18. Distribution Statement | |
| 19. Security Classif. (of this report) Unclassified | 20. Security Classif. (of this page) Unclassified | 21. No. of Pages 55 | 22. Price* |

* For sale by the National Technical Information Service, Springfield, Virginia 22161

FOREWORD

This document describes the work conducted and completed by the Commercial Products Division, Pratt & Whitney Aircraft Group of United Technologies Corporation during Lean Premixed Prevaporized Fuel Combustor Conceptual Design Study Program. This final report was prepared for the National Aeronautics and Space Administration Lewis Research Center in compliance with the requirements of Contract NAS3-21256.

The authors of this report wish to acknowledge the guidance and assistance of Dr. Edward J. Mularz, NASA Project Manager of the LPP Fuel Combustor Conceptual Design Study Program. The authors would also like to thank all the investigators of the Stratospheric Cruise Emission Reduction Program for providing useful LPP combustor design information, and Drs. G. J. Sturgess and S.A. Syed of the Combustor/Turbine Durability Powerplant Analysis Group of Pratt & Whitney Aircraft for their assistance on the feasibility of aerodynamic air modulation.

PRECEDING PAGE BLANK NOT FILMED

TABLE OF CONTENTS

| Section | | Page |
|---------|---|------|
| | SUMMARY | 1 |
| | INTRODUCTION | 2 |
| 1.0 | PROGRAM DESCRIPTION | 3 |
| | 1.1 General Description | 3 |
| | 1.2 Program Plan | 4 |
| | 1.2.1 Task I - Combustor Design | 4 |
| | 1.2.2 Task II - Design Analysis | 4 |
| | 1.2.3 Task III - Design Ranking | 5 |
| | 1.3 Program Goals | 6 |
| | 1.3.1 Emissions Goals | 6 |
| | 1.3.2 Performance Goals and Design Requirements | 6 |
| 2.0 | DESIGN STUDY | 7 |
| | 2.1 Introduction | 7 |
| | 2.2 Reference Engine | 7 |
| | 2.3 LPP Combustor Design Considerations | 9 |
| | 2.3.1 Introduction | 9 |
| | 2.3.2 LPP Combustor Phenomena | 9 |
| | 2.3.3 Fuel-Air Preparation | 11 |
| | 2.3.4 Autoignition and Flashback | 13 |
| | 2.3.5 Stability | 14 |
| | 2.3.6 Cooling and Dilution Air Requirements | 15 |
| | 2.3.7 Cycle and Performance Constraints | 16 |
| 3.0 | CONCEPTUAL DESIGNS AND ANALYSIS | 18 |
| | 3.1 Introduction | 18 |
| | 3.2 Concept 1 | 18 |
| | 3.2.1 Concept Description | 18 |
| | 3.2.2 Concept Assessment | 21 |
| | 3.3 Concept 2 | 26 |
| | 3.3.1 Concept Description | 26 |
| | 3.3.2 Concept Assessment | 29 |
| | 3.3.3 Concept 2 Adaptation to JT9D | 31 |
| | 3.4 Concept 3 | 34 |
| | 3.4.1 Concept Description | 34 |
| | 3.4.2 Concept Assessment | 36 |
| | 3.5 Concept 4 | 40 |
| | 3.5.1 Concept Description | 40 |
| | 3.5.2 Concept Assessment | 42 |

TABLE OF CONTENTS (Cont'd)

| Section | | Page |
|---------|--------------------------------------|------|
| 4.0 | ENGINE FEASIBILITY CRITERIA | 44 |
| | 4.1 Mechanical Integrity/Reliability | 44 |
| | 4.1.1 Thermal Analysis | 44 |
| | 4.1.2 Reliability | 44 |
| | 4.2 Cost and Time to Develop | 46 |
| | 4.3 Weight Ranking | 47 |
| | 4.4 Failure Analysis | 47 |
| 5.0 | COMPARISON OF CONCEPTS | 49 |
| | 5.1 Concept Ranking | 49 |
| | 5.1.1 Rating Procedure | 49 |
| | 5.1.2 Results | 50 |
| 6.0 | CONCLUDING REMARKS | 52 |
| 7.0 | REFERENCES | 54 |

LIST OF ILLUSTRATIONS

| Figure | Title | Page |
|--------|--|------|
| 1-1 | Program Schedule | 3 |
| 2-1 | Layout of JT9D-70 Combustor | 8 |
| 2-2 | Variation of NO _x Emissions with Flame Temperature | 10 |
| 2-3 | Effect of Residence Time on NO _x Emissions | 10 |
| 2-4 | Effect of Pressure on Ignition Delay and Vaporization Times for JP-4 | 11 |
| 2-5 | Effect of Mixture Uniformity on Rate of Formation of Nitric Oxide (from Ref. 8) | 12 |
| 2-6 | Autoignition Delay Times as Function of Inlet Air Pressure and Temperature (from Ref. 9) | 13 |
| 2-7 | Cooling and Dilution Airflow Requirements of Lean Combustion | 15 |
| 3-1 | Variable Geometry LPP Combustor - Concept 1 | 19 |
| 3-2 | Flame Stability Curve | 23 |
| 3-3 | Stability Correlation Curve | 24 |
| 3-4 | Autoignition of Liquid Hydrocarbon Fuel Sprays in Air | 24 |
| 3-5 | Variable Geometry LPP Combustor - Concept 2 | 27 |
| 3-6 | Preliminary Fuel Schedule for Concept 2 | 28 |
| 3-7 | CO and THC Emissions at Idle for Various IBZ Equivalence Ratios | 32 |
| 3-8 | NO _x Emissions at SLTO for Various IBZ Equivalence Ratios | 32 |
| 3-9 | Concept 2 Adapted to JT9D Engine | 33 |
| 3-10 | LPP Combustor - Concept 3 | 35 |

LIST OF ILLUSTRATIONS (Cont'd)

| Figure | Title | Page |
|--------|---|------|
| 3-11 | Schematic of Airflow Modulation by Bleeds | 38 |
| 3-12 | Emissions Estimates for Concept 3 | 39 |
| 3-13 | LPP Combustor - Concept 4 | 41 |
| 4-1 | Thermal Analysis Results | 45 |

LIST OF TABLES

| Table | Title | Page |
|-------|---|------|
| 2-I | Representative Operating Conditions for the Energy Efficient Engine | 8 |
| 2-II | Parametric Study on Degree of Vaporization | 12 |
| 3-I | Concept 1 Design Analysis | 22 |
| 3-II | Concept 2 Design Analysis | 30 |
| 3-III | Comparison of Concept 2 Emission Estimates for E ³ and JT9D Engine Application | 34 |
| 3-IV | Concept 3 Design Analysis | 37 |
| 3-V | Estimated NO _x Emissions at Cruise | 40 |
| 3-VI | Concept 4 Design Analysis | 43 |
| 4-I | LPP Combustor Failure Analysis of Preliminary Designs | 48 |
| 5-I | Concept Rating Sheet | 51 |

SUMMARY

This report presents the results of a nine-month design study to identify and analytically evaluate lean, premixed, prevaporized (LPP) fuel combustor concepts utilizing variable geometry and other advanced flow control techniques. Although the primary goal of this program was low oxides of nitrogen (NO_x) at stratospheric cruise conditions, both the currently proposed ground level EPA emission standards and combustor performance and operational requirements typical of advanced subsonic aircraft engines were retained as goals as well.

Four combustor concepts were designed for the NASA/Pratt & Whitney Aircraft Energy Efficient Engine (E^3) envelope and cycle. The Energy Efficient Engine is configured as a high bypass ratio (6.5:1) engine in the 190,000 Newton thrust class with a cycle pressure ratio of approximately 38:1 at cruise and a combustor exit temperature in excess of 1600K at sea level takeoff conditions. The combustor designs developed are applicable to other advanced aircraft engines, and one of the concepts was selected for adaptation to the JT9D engine cycle and envelope. The basic design philosophy underlying all the concepts considered was that of lean, premixed, prevaporized combustion utilizing axial-flow full annular designs constrained to the current E^3 configuration. Achieving the NO_x emission goals will require equivalence ratios between 0.5 and 0.6 at reduced residence times, while at low power a significantly higher equivalence ratio must be maintained to ensure high combustion efficiency and low emissions of carbon monoxide (CO) and total hydrocarbons (THC). This stoichiometry must be controlled while maintaining acceptable combustor pressure drop, stability, temperature distribution and structural integrity.

The four designs selected allow evaluation of three variable geometry techniques used in various combinations with advanced burner designs. The techniques include both primary and dilution zone control as well as aerodynamic methods for varying combustor inlet velocity profile. Mechanical devices were designed to modulate combustor areas while a diffuser wall bleed technique serves as the aerodynamic control.

Each of the four designs has been analyzed for its potential in meeting the emission, performance and operational goals of the program and then compared for the purpose of ranking the designs. Based on the analytical projections made during this conceptual design study, two of the concepts offer the potential of achieving the emission goals while nearly satisfying all of the performance requirements. However, the projected operational characteristics and reliability of any of these concepts to perform satisfactorily over an entire aircraft engine envelope require extensive experimental substantiation before engine adaptation can be considered.

INTRODUCTION

Previous technical efforts have focused on the reduction of aircraft pollution in the vicinity of airports. Additionally, recent studies have indicated there may be potential problems associated with the introduction of nitric oxides into the stratosphere. The consequences of depletion of the ozone layer have been studied by the U. S. Department of Transportation under the Climatic Impact Assessment Program (CIAP), and the report of findings (Ref. 1) from this study concluded that the control of oxides of nitrogen at high altitude may be required in the future.

As a result of the findings of the CIAP, it has been recommended to the Department of Transportation that research and development be aimed toward a reduction in the emission of oxides of nitrogen by a factor of 10 within the next decade, and that the research program be aimed at substantial further improvement in emissions to be realized in practical engines during the ensuing decade.

In response to these needs, NASA initiated the Stratospheric Cruise Emission Reduction Program (SCERP) to develop lean, premixed, prevaporized (LPP) combustor technology capable of reducing critical exhaust emissions over the full range of aircraft operation. The initial phase of a four-phase program was begun in 1976 to examine various aspects of LPP combustion which required more understanding and to establish design criteria for concepts having the potential of meeting program objectives.

This report describes the results of an initial Phase I study program to identify, design and evaluate LPP combustor concepts utilizing variable geometry and/or other flow control techniques. The primary goal of this program is the significant reduction of emissions of nitrogen oxides at stratospheric cruise conditions.

A summary of the plan and goals of the subject program is provided in Section 1.0. Section 2.0 contains a description of the reference engine (E³) and combustor used as a basis for the program work and the criteria considered for the design work. Section 3.0 presents the aerodynamic and mechanical design features and Section 4.0 describes the engine feasibility criteria. Section 5.0 evaluates the conceptual designs for their probability of meeting the design requirements and program goals and Section 6.0 presents the concluding remarks.

1.0 PROGRAM DESCRIPTION

1.1 GENERAL DESCRIPTION

The overall objective of this conceptual design study was to identify promising lean premixed-prevaporized combustor designs which incorporate variable geometry, and examine their potential for meeting performance, emissions, and operational requirements of advanced aircraft gas turbine engines. The ultimate goal is to reduce the emissions of oxides of nitrogen at stratospheric cruise conditions. The specific objectives of this study were to:

- o Design four combustors selected by NASA from concepts previously presented
- o Evaluate the predicted performance and emissions characteristics of these combustors
- o Evaluate their potential to meet engine operational requirements as well as their compatibility with current engine designs
- o Identify design problems associated with the application of variable combustor geometry

To accomplish these objectives a nine (9) month technical effort was undertaken. The schedule for this program is shown in Figure 1-1. The program approach involved an initial design task where the combustor envelope (diffuser, fuel system, combustor contour, variable geometry mechanisms) were defined. This was followed by a design analysis task in which the concepts were evaluated for performance and operational characteristics, potential for meeting the emissions goals and problem areas peculiar to the variable geometry features. The third task involved the rating of the four candidate concepts from the results of the previous task.

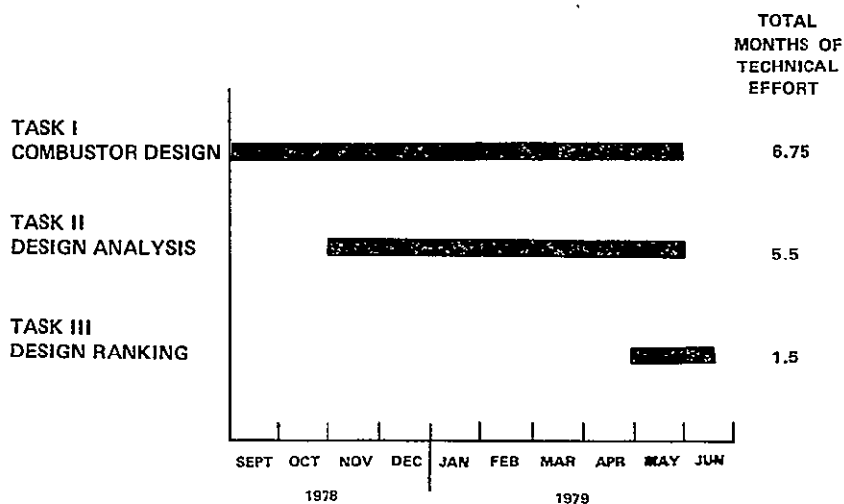

Figure 1-1 Program Schedule

1.2 PROGRAM PLAN

1.2.1 Task I - Combustor Design

The combustor design was an axial flow annular type. During the Task I effort, preliminary flow paths and splits were defined. Flameholder and/or swirler sizing as well as fuel introduction method and schedule were determined, and the variable geometry mechanisms specified.

The designs included the combustor and all other necessary components such as the diffuser, fuel premixing components, variable geometry devices, etc. Design features and major components of the fuel system were specified and fuel injection and distribution techniques identified. Techniques for actuating the variable geometry hardware were indicated, including supports and pivot points, linkages, actuators and seals. All combustor materials and combustor liner cooling techniques were shown.

The combustor concepts were constrained to the current Energy Efficient Engine configuration. However, the advanced energy efficient turbofan engines were considered sufficiently long term so that the geometry of the burner and diffuser cases, including combustor section length, limiting radii and diffuser configuration could be altered if found either desirable or necessary.

The design layouts included enough detail to indicate how the various parts would assemble. Both a cross-sectional view across the combustor annulus at the combustor centerline as well as one or more circumferential views were given to provide sufficient information to completely define the combustor geometry. The location and sizes of all air passages, including dilution holes, film cooling slots, and convective cooling passages were specified.

1.2.2 Task II - Design Analysis

Each of the combustor designs developed in Task I was analyzed and evaluated for the potential for meeting the combustor performance goals as well as for feasibility for development into a practical engine system. The designs were analyzed for each of the following factors over the full range of combustor operation.

(a) Performance - including predictions of

- o pressure loss
- o combustion efficiency
- o combustion stability
- o exit radial temperature profile
- o pattern factor
- o autoignition or flashback characteristics

- (b) Emissions - including predictions of
 - o NO_x, CO, THC emissions as well as smoke for the EPA landing takeoff cycle and altitude cruise conditions
- (c) Operational considerations - including predictions of
 - o altitude relight
 - o transient behavior
 - o starting performance
 - o sensitivity to bleed flows
- (d) Control requirements - including assessment of
 - o impact of variable geometry on engine control system
 - o control system input requirements
 - o need for new or additional sensing techniques
- (e) Mechanical integrity/reliability - including predictions of
 - o combustor hardware temperatures
 - o potential fuel coking
 - o potential liner failure
- (f) Cycle considerations - including evaluation of impact of burner design on
 - o engine cycle
 - o engine performance
 - o engine weight

In those portions of the analyses where a significant tradeoff existed between two or more parameters tradeoffs were identified and the results evaluated. Also included in the analyses was an elementary failure analysis to identify potential failure modes.

1.2.3 Task III - Design Ranking

Following the completion of Task II, each of the combustor designs were rated in each of the categories identified in Section 1.2.2 items (a) through (f), according to their probability of meeting the design requirements. The following rating criteria were used:

| Rating | Description |
|--------|--------------------------------------|
| 1.1 | Exceeds requirements |
| 1.0 | Likely to meet requirements |
| 0.7 | Needs more work to meet requirements |

- 0.3 Needs considerably more work
- 0.1 Very little chance of meeting requirements
- 0 Will not meet requirements

The four combustor concepts studied in Tasks I and II were ranked according to their relative development risk, i.e., the ability to convert the combustor concept into an operational engine combustor. The most promising design was selected and adapted to the JT9D-7 engine envelope and operating conditions.

1.3 PROGRAM GOALS

1.3.1 Emissions Goals

Design emissions goals for the study were as follows:

- o NO_x EI \leq 3 g/kg at subsonic cruise
- o 1984 EPA emissions standards for T-2 thrust class aircraft over the landing - takeoff cycle

| | | |
|--------------------|--------|---------------|
| CO EPAP | \leq | 25 g/kNewton |
| THC EPAP | \leq | 3.3 g/kNewton |
| NO_x EPAP | \leq | 33 g/kNewton |
| Smoke No. | \leq | 20 |

1.3.2 Performance Goals and Design Requirements

Design requirements and performance goals for the study were as follows:

- o combustion efficiency:
 - $\eta_b \geq$ 99.9 percent at sea level takeoff
 - $\eta_b \geq$ 99.5 percent at engine idle
 - $\eta_b \geq$ 99 percent at all other operating conditions
- o total combustor pressure loss, $\Delta P/P \leq$ 5.5 percent at all operating conditions except idle.
- o altitude relight capability \geq 10.7km
- o all combustor designs were to have adequate cooling and structural integrity to be representative of aircraft engine combustors.

2.0 DESIGN STUDY

2.1 INTRODUCTION

Gas turbine engine combustors must satisfy many functional requirements simultaneously. The combustor must be capable of burning all the fuel efficiently while constraining exhaust pollutants to stringent limits. The mean temperature of the gases leaving the combustion section has to be commensurate with cycle efficiency requirements, but the maximum local temperature and temperature radial distribution (profile) must be compatible with turbine material limitations. All functions must be performed with minimum pressure loss, since such losses represent a reduction in available energy to the cycle.

The combustor must ignite the fuel-air mixture easily and be capable of maintaining it lit over wide ranges of fuel temperature, ambient air temperature and ambient pressure. It must not be subject to blowouts resulting from either too rich or too lean fuel-air mixtures, and it must retain its efficiency over the required operating range of the engine. Off-design temperature rise capability has to be compatible with the rotating machinery characteristics such that smooth acceleration of the engine can be achieved. Response of the combustor to throttle movements must be rapid to permit safe flight operations.

The combustion section is required to perform all these functions while containing a high temperature combustion process and not compromising the durability of the engine. All combustion chambers, whatever their principle of operation or geometric arrangement, must conform to the basic requirements described above.

A typical current service aircraft engine combustor utilizing conventional techniques is shown in Figure 2-1. This combustor is designed to satisfy all the above requirements.

2.2 REFERENCE ENGINE

The lean premixed-prevaporized combustor conceptual components were designed for the cycle and performance parameters anticipated for the Energy Efficient Engine (E³), currently being developed under a contract with NASA. The E³ is configured as a high bypass ratio (6.5:1) engine in the 190,000 Newton thrust class, with a pressure ratio of about 38:1 at the cruise design point. Representative operating conditions for the Energy Efficient Engine for the design points of the landing/takeoff cycle and for maximum rated cruise are presented in Table 2-1.

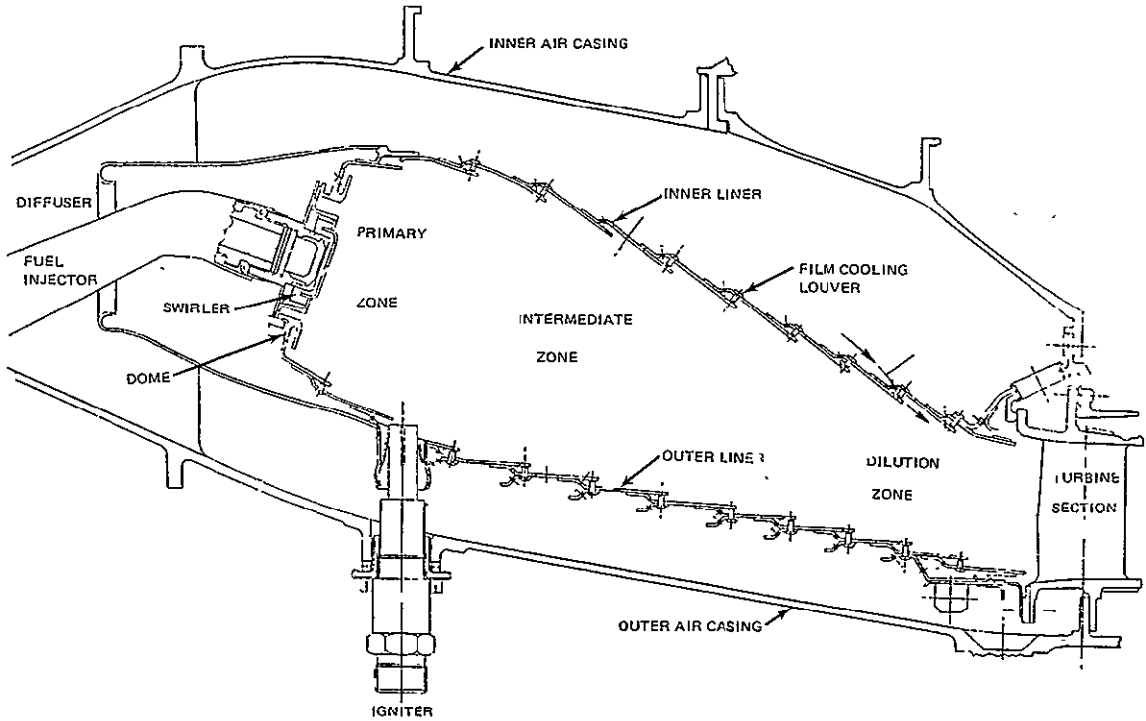

Figure 2-1 Layout of JT9D-70 Combustor

TABLE 2-1

REPRESENTATIVE OPERATING CONDITIONS FOR THE ENERGY EFFICIENT ENGINE

| | Ground ^(a) | | | Sea-Level Takeoff | Max ^(b) Cruise |
|---------------------------------|-----------------------|----------|--------|----------------------|------------------------------|
| | Idle | Approach | Climb | | |
| Combustor Inlet Temperature (K) | 473 | 621 | 777 | 810 | 754 |
| Combustor Inlet Pressure (atm) | 4.4 | 11.7 | 27.0 | 31.2 | 13.8 |
| Air Flow Rate (kg/sec) | 14.0 | 31.6 | 62.4 | 70.2 | 31.7 |
| Combustor Exit Temperature (K) | 815 | 1118 | 1522 | 1611 | 1533 |
| Combustor Exit Pressure (atm) | 4.1 | 11.0 | 25.5 | 29.5 | 13.1 |
| Fuel Flow Rate (kg/sec) | 0.13 | 0.43 | 1.38 | 1.68 | 0.74 |
| Overall Fuel-Air Ratio | 0.009 | 0.0137 | 0.0221 | 0.0240 | 0.023 |

(a) Std. Day - uninstalled (7% power)

(b) Alt = 10.7 km, Mn = 0.8

2.3 LPP COMBUSTOR DESIGN CONSIDERATIONS

2.3.1 Introduction

The ideal variable geometry LPP combustor would be designed to modulate the combustor air flow, mix and vaporize the fuel in air in proper proportions for each engine operating condition, and burn the controlled homogeneous mixture efficiently, thereby minimizing exhaust pollutants. The successful application of LPP combustion to practical engine combustors imposes a number of considerations that often result in contradictory requirements. Some of these factors, such as the characteristics of the compressor discharge flow field, fuel preparation and vaporization, autoignition and flashback, flame stability, and cooling and dilution air requirements will be discussed in Sections 2.3.2 through 2.3.7.

2.3.2 LPP Combustor Phenomena

The conclusion to be drawn from the numerous emission reduction programs conducted by Pratt & Whitney Aircraft and from other investigations (Refs. 2, 3, 4, 5) is that the lean, premixed, prevaporized (LPP) combustion technique offers the best potential of meeting all of the program goals. Both theoretical and experimental studies (Ref. 2, 3) have shown that the concentration of nitrogen oxides produced by the oxidation of atmospheric nitrogen during combustion is nearly exponentially dependent on flame temperature (Figure 2-2). Furthermore, it has been shown in these studies that above 1900K the gas phase reactions are fast enough to produce significant amounts of NO_x . Therefore, if the combustor were to operate such that the local fuel-air ratio was below approximately 60 percent stoichiometric everywhere, then the production of NO_x would be negligible.

The implications of lean combustion in minimizing NO_x emissions are quite evident. The desired uniformity and control of the fuel-air mixture in the combustion zone precludes droplet burning. The fuel must be premixed and prevaporized prior to introduction into the primary zone of the combustor. The exhaust emission reduction potential, particularly that for NO_x reduction, of lean premixed-prevaporized (LPP) combustion has been demonstrated in laboratory experiments (Ref. 2, 4). Figure 2-3 (from the data of Ref. 2) shows the interrelationship of combustion residence time, equivalence ratio and combustion efficiency and the impact of these parameters on NO_x emissions from an LPP system. It illustrates that NO_x emissions may be reduced by reductions in equivalence ratio and/or residence time while maintaining high levels of combustion efficiency. However, it must be recognized that these controlled rig tests represent, at best, the simulation of a fixed operating condition in the overall engine cycle. In order to exploit its full potential, and to broaden its useful operating range, the LPP system requires some form of variable geometry. Considerable basic technology and component development is necessary to optimize the LPP type combustor from a performance as well as a emission reduction viewpoint over the entire operating range of the gas turbine engine.

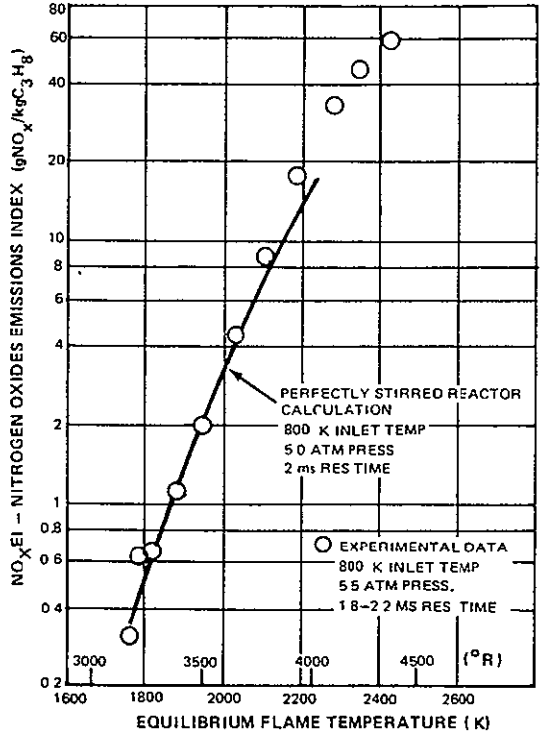

Figure 2-2 Variation of NO_x Emissions with Flame Temperature

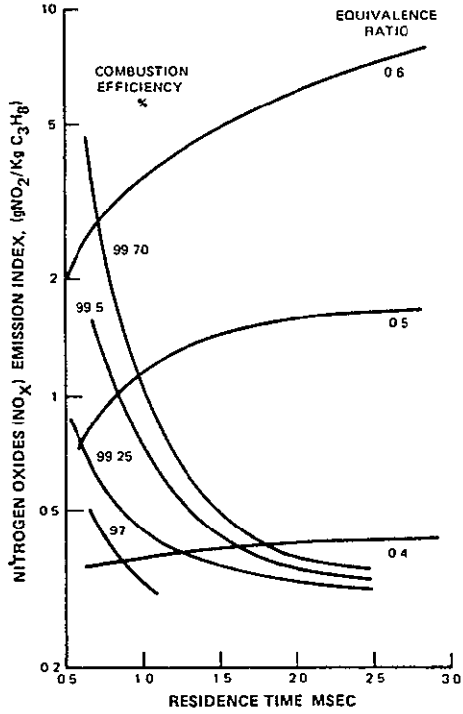

Figure 2-3 Effect of Residence Time on NO_x Emissions. Inlet mixture temperature, 800K; inlet pressure, 5.5 atm; reference velocity 25 and 30 m/sec (from Ref. 2)

Before an LPP combustor concept can be designed for a practical advanced aircraft engine, serious consideration and concern must be given to the basic factors that follow.

2.3.3 Fuel-Air Preparation

It is recognized that even in the ideal case of a uniform flow field feeding the premixing passages, fully premixed and prevaporized mixtures may not be obtainable over the entire engine operating range. In the absence of an external vaporizer, some of the factors that influence fuel vaporization are air temperature and pressure, combustor inlet turbulence level (and possibly scale), fuel droplet size and distribution, and premix passage length and residence time. Figure 2-4 (from Ref. 5) shows analytical predictions of fuel droplet evaporation as a function of pressure. When the ignition delay characteristics of Jet-A fuel (from Ref. 6) are superimposed, it can be seen that vaporization will be limited by premix passage autoignition restrictions. The limits imposed by autoignition on passage length makes it imperative that optimum atomization and distribution be achieved. A spray evaporation model developed during the PWA/NASA Catalytic Burner Program (Ref. 7) was used to calculate the degree of fuel vaporization for parametric variations in passage length, velocity and droplet size. The results of this analytical investigation as shown in Table 2-II point out the importance of ultra fine atomization at the design conditions for high pressure ratio advanced gas turbine combustors. New approaches to fuel atomization aimed at the production of very small droplets ($\leq 40\mu\text{SMD}$) should be explored. The fuel injector must be designed with as many injection sources as practical, without impinging fuel on liner walls and with no wakes where fuel could be entrained and possibly exceed autoignition limits.

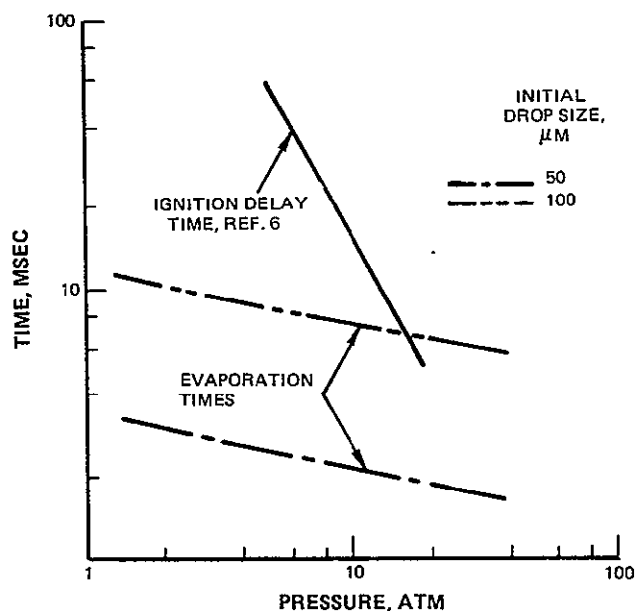

Figure 2-4 Effect of Pressure on Ignition Delay and Vaporization Times for JP-4. Inlet air temperature, 833K (from Ref. 5)

TABLE 2-II
PARAMETRIC STUDY ON DEGREE OF VAPORIZATION

| Premix Passage Length | 7.6 cm | | | 10.2 cm | | |
|-----------------------|-------------------|---------|---------|---------|---------|---------|
| | Air Velocity | 61 m/s | 91 m/s | 122 m/s | 61 m/s | 91 m/s |
| Residence Time | 1.25 ms | 0.83 ms | 0.63 ms | 1.67 ms | 1.11 ms | 0.83 ms |
| SMD* | Percent Vaporized | | | | | |
| 10 μ | 80.7% | 77.9% | 75.9% | 83.0% | 80.2% | 78.1% |
| 20 μ | 70.3% | 67.5% | 65.4% | 72.6% | 69.7% | 67.7% |
| 40 μ | 60.0% | 57.1% | 55.1% | 62.2% | 59.3% | 57.3% |

Inlet Pressure 31.2 atm. Temperature 810K.

* initial injector droplet size (Sauter mean diameter)

An analytical prediction (Ref. 8) showing the effect of burning zone uniformity on the rate of NO formation is presented in Figure 2-5. It is apparent that the NO_x emission characteristics should be assessed for those engine operating conditions which result in deviations from homogeneous fuel mixing and vaporization.

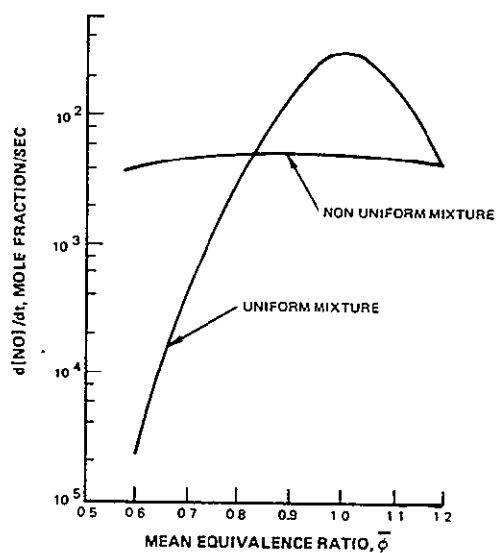

Figure 2-5 Effect of Mixture Uniformity on Rate of Formation of Nitric Oxide (from Ref. 8)

2.3.4 Autoignition and Flashback

Perhaps the most formidable obstacles to the successful application of the LPP combustor in advanced aircraft engines is the phenomena of autoignition and flashback. Many of the experimental rig programs including those sponsored by NASA have experienced autoignition or flashback problems (Ref. 4). Autoignition occurs when the residence time of the fuel-air mixture in the premixing passage exceeds the ignition delay time. Flashback occurs when the flame propagation velocity exceeds the mixture velocity, enabling the flame to detach from the intended flameholder and propagate into the premixing passage. In either case, autoignition or flashback, burning takes place in the premixing/prevaporizing passage, resulting in potential damage to the combustor and possibly the entire engine.

Autoignition delay data reported in the literature require careful interpretation with respect to the test apparatus and measurement method used. Some results are contradictory. All experimenters have had difficulty in rapidly obtaining a uniform fuel-air mixture and in determining the extent of fuel vaporization.

The autoignition characteristics of Jet-A fuel, as reported in Ref. 9, are presented in Figure 2-6. Some of the E³ operating temperatures and pressures are superimposed on the figure. Clearly SLTO operating condition is the power setting that allows minimum margin for autoignition. In designing the premixing passages for the LPP system, precautions have to be taken to minimize and/or avoid potential flow problems, such as wakes behind variable geometry devices or fuel injectors, which could increase the residence time of fuel-air mixture in the premixing passage. If flow distortions resulting from variable geometry devices are unavoidable, the design should attempt to restrict these problems to operating conditions corresponding to lower pressures and temperatures, e.g., idle. Incomplete mixing/vaporization, hence higher NO_x emissions at SLTO power conditions, must be weighed against providing adequate margin to avoid autoignition.

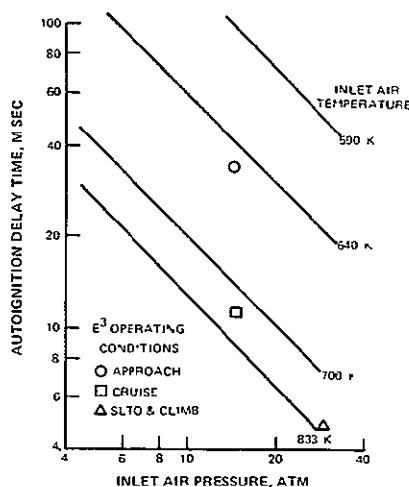

Figure 2-6 Autoignition Delay Times as Function of Inlet Air Pressure and Temperature (from Ref. 9)

Flashback is another performance constraint on the LPP combustor that requires serious design concern (Reference 10). Two major types of flashback that must be avoided are: (1) flashback occurring in the free stream, and (2) flashback occurring through the low velocity flow in the boundary layer along the surfaces of the flameholder, any support struts, and the walls of the premix/prevaporized passage.

The most obvious free stream mechanism would involve flashback due to a flow reversal in the bulk flow through the combustor. This reversal could be a result of compressor surge, or combustion instability. Flashback can also occur in the absence of flow reversal if the turbulent flame speed through the gas in the premixing passage is greater than the local bulk velocity. While lean combustion tends to reduce flame speeds, other factors associated with the engine cycle, such as high temperatures, pressure, turbulence levels and preignition reactions due to applicable residence times at high temperature levels, cause increased flame speed.

Although the influence of these factors is qualitatively known, there is an inadequate amount of data on the quantitative effect these parameters have on flashback for aircraft fuels over the operating regime of the LPP combustor. Control of the flashback phenomenon can be approached by controlling wall temperatures, reducing equivalence ratios near surfaces, and by the application of free stream pressure gradient.

2.3.5 Stability

The combustor front end airflow required to establish lean combustion during high power operation may result in flame blowout at lower power conditions. There are two approaches to alleviate this design problem. The first, which is a part of this program, is to employ variable geometry to modulate the airflow in order to meet the stability requirements over a wide range of operating conditions. The second approach is to utilize a pilot combustor incorporated into the LPP system. The pilot combustor would be used for starting, ground idle and altitude relight; the LPP system would be staged in the power conditions above idle. This would require a smooth transition between the pilot and LPP stages to ensure proper acceleration and deceleration characteristics. This may necessitate more complex fuel injector and flameholder designs that have hitherto been contemplated.

Studies have been made (Ref. 11) to evaluate the effect of flameholder geometry on blowout limits and methods of enhancing stability characteristics through flameholder design. The results of this program will provide data required in the subsequent design of lean combustor concepts. An additional design concern in the application of fuel staging is fuel nozzle coking, which can result after a particular stage has been shutdown during a change in engine operating condition.

2.3.6 Cooling and Dilution Air Requirements

Current high bypass ratio commercial engines, such as the JT9D, employ annular combustors constructed with Hastelloy-X material. The liners are fabricated from a series of cylindrical louvers which are film cooled. Thermal barrier coatings, such as magnesium zirconate, are applied to the hot gas side of the liner to reduce the maximum metal temperature and approximately forty-five percent of the combustor airflow is required to cool the JT9D liners. The effect of utilizing large quantities of air in the front end of the lean premixed combustor on cooling/dilution air requirements is shown in Figure 2-7.

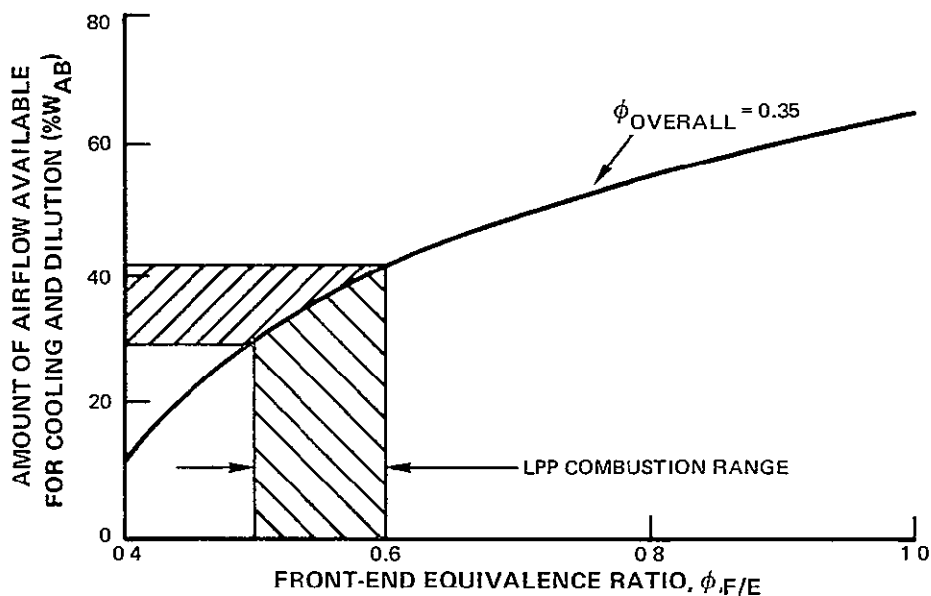

Figure 2-7 Cooling and Dilution Airflow Requirements of Lean Combustion

Control of combustor exit temperature pattern factor and radial profile will continue to require approximately the amount of dilution air that is used in current engines. The implication is that only 25 percent of the combustor airflow is left to cool the premixed combustor designed with a front end equivalence ratio of 0.55. The result of a study to define wall temperatures when louvers are employed in LPP conceptual designs is presented in Section 4.1.1. Lower primary zone gas temperatures and flame radiation, and most importantly, a significantly shorter burner liner all contributed towards maintaining liner wall temperatures at satisfactory levels with only 25 percent combustor airflow for film cooling. To achieve the desired liner durability in the more severe operating environment of future aircraft engines, and also to reduce liner cooling air requirements and thereby release combustor air for exit temperature distribution and emissions control, more efficient cooling techniques must be applied to the liner design.

Pratt & Whitney Aircraft has been developing, through analytical and experimental investigations, advanced combustor liner configurations which will require less than half of the air required for the current conventional film cooling liner. Candidate cooling configurations include Counter-Flow Film cooling, Counter-Parallel FINWALL[®] (CPF_W), Impingement Transpiration cooling, and Impingement-Film cooling. The effect of applying one of these advanced cooling schemes (CPF_W) to one of LPP conceptual designs is shown in section 4.1.1.

2.3.7 Cycle and Performance Constraints

The successful application of LPP combustion to practical engine combustors imposes a number of considerations that often result in contradictory requirements. Some of these factors such as fuel preparation and vaporization, autoignition and flashback, flame stability and cooling and dilution air requirements have already been discussed.

Since premixed-prevaporized fuel combustors have demonstrated the potential for significant reduction in NO_x emissions via lean burning, one method of obtaining efficient combustion throughout the engine operating spectrum is to employ LPP combustion in conjunction with variable geometry features. Variable geometry (or continuous air staging) offers the possibility of smooth variation in combustor stoichiometry relative to fuel staging, or it could be employed together with fuel staging to optimize a combustor for several operating conditions as opposed to the two-stage combustor. The utilization of variable geometry, though desirable from a combustor performance viewpoint, introduces significant complexity and difficulty with respect to combustor design. A typical single-stage combustor operating at stoichiometric fuel-air ratio at idle power setting would require approximately 15 percent of the total combustor airflow in the front end. The same stage at cruise or SLTO power setting would require approximately 65 percent of the combustor airflow to maintain an equivalence ratio of 0.55. Therefore, efficient and viable techniques of diverting up to 50 percent of combustor airflow from one operating condition to another must be evolved if the full potential of the LPP combustor is to be exploited. Fuel staging would reduce the amount of air to be staged. Movement of air of such magnitude will influence the combustor section pressure drop characteristics at different operating conditions. Some form of additional coordinated variable geometry is needed in order to vary the amounts of air employed in liner wall cooling and dilution so as to maintain a constant liner pressure drop. Utilization of 65 percent of the available combustor airflow in the front end premixing process leaves only 35 percent for dilution and liner cooling.

The anticipated design problems with variable geometry features are their control, operational characteristics and durability. The complex air staging techniques will require sophisticated control systems and sensors in order to keep the combustor stoichiometry at desired levels for various flight conditions. The challenge presented to the control

system designer is to meet desired engine performance requirements with the least complex system possible. Minimizing complexity enhances the potential of meeting the ever present goals of high reliability and low weight, cost and maintainability.

The major types of control systems are (1) on-off control, (2) openloop modulating control and (3) closed-loop modulating control. The on-off control is the simplest approach of the three types and provides the lowest degree of control. The output control element, a bleed air valve for example, would be in the open or the closed position as a function of an activation signal. The open-loop modulating control system is more complex and provides more precise control than the on-off control system. In an open-loop modulating system, the output control element, such as a bleed air valve, would be capable of being positioned at any location between full open and full closed. The third type of control system, a closed-loop modulating control, is the most complex system and maximizes the engine performance benefits. This type of control could utilize, for example, a modulating bleed air valve, with the position of the valve being set at whatever location is required to obtain the desired effect.

A major factor that must be addressed in determining control requirements is the impact that the precision of the variable geometry setting has on engine performance. If the performance benefit is very sensitive to clearance, a closed-loop modulating system will probably be required. If the benefit is much less sensitive, on-off control will probably be acceptable.

There are a number of actuating mechanisms for variable geometry devices that can be adopted. Prime concerns in selecting the proper approach include compatibility with the engine control system, weight, complexity, and reliability. Specific devices are described in detail in Section 3.0. Nevertheless, for the purpose of defining the general types of activating mechanisms that can be considered, the following categories are listed: (1) hydraulic; (2) mechanical; (3) electromechanical; (4) air and vacuum systems; (5) burner pressure drop driven systems; and (6) bimetallic movement.

The influence of the control system in the overall operation of the engine will have to be evaluated. The variable geometry system should be designed such that if it fails, it will not impact the safe operation of the engine.

3.0 CONCEPTUAL DESIGNS AND ANALYSIS

3.1 INTRODUCTION

Four concepts were selected for design, analysis and evaluation as potential lean premixed prevaporized configurations. The concepts selected allowed the evaluation of three variable geometry techniques used in various combinations with advanced burner designs. In order to ensure the ultimate adaptability of the proposed designs to actual engine hardware, it was necessary to restrict the selection process as described below:

- (1) Simultaneous control of IBZ (Initial Burning Zone) and dilution zone airflow would be required in order to maintain a nearly constant combustor section pressure loss at all operating conditions. Although increasing the complexity significantly, the variation in pressure loss resulting from individual control was felt to be intolerable.
- (2) Any attempt to control airflow upstream of the IBZ injection plane would have to be carefully designed to minimize wakes.
- (3) The variable geometry mechanism would have to be designed for fast response.
- (4) A safety factor of about 2.5 would be applied to autoignition residence time data.

3.2 CONCEPT 1

3.2.1 Concept Description

The design of the first concept is presented in Figure 3-1. The concept features 24 premix passages each equipped with a translating centerbody that provides both the desired area modulation between idle and SLTO and a bluff body recirculation zone for stability. The design evolved from a desire to meter front end airflow at the IBZ injection plane and accelerate the flow in order to minimize the possibility of flashbacks.

The conical flameholder is based on a design evaluated in a NASA program, Ref. 12, that demonstrated low NO_x emissions and overall good stability. The reference design was used to establish the overall cone size and shape based on a desired degree of blockage, while the number of passages, 24, was selected for compatibility with the 24-strut design of E^3 . The outer contour of the passage was sized to allow the annulus area to vary as required for equivalence ratio control. At idle conditions an IBZ equivalence ratio of 1.0 is maintained to ensure high combustion efficiency and low emissions of carbon monoxide and unburned hydrocarbons, while at high power the equivalence ratio is reduced to 0.55 to control oxides of nitrogen. The test

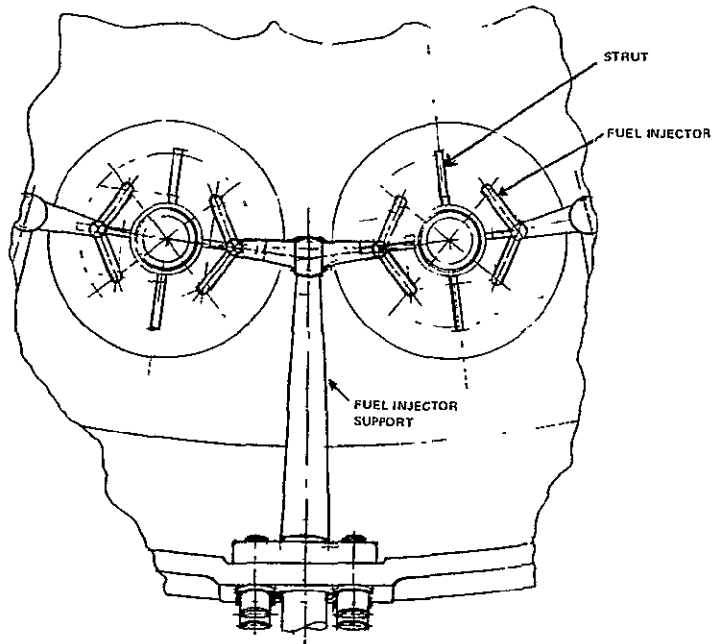
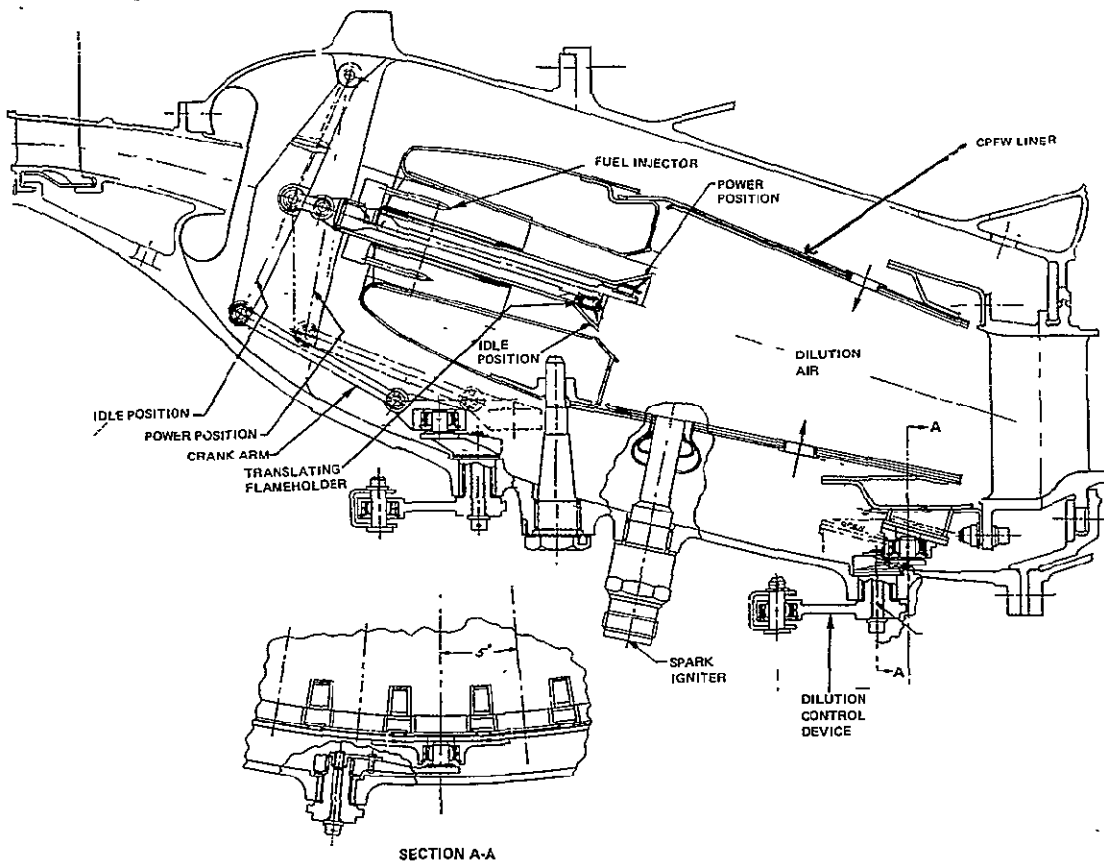

Figure 3-1 Variable Geometry LPP Combustor - Concept 1

results from previous low emissions combustor programs, Refs. 13 and 14, were used in selecting an idle IBZ of 1.0 while the experiment premix data of Anderson, Ref. 2, were used in selecting a value of 0.55 for high power operation.

As shown, the 24 premix passages are located downstream and between the diffuser case struts. The translating centerbody is centered in each passage, guided by impregnated graphite sleeve bearings at each end of a center tube supported by four struts. Movement of the plug is accomplished by the ball jointed linkage shown which is connected to the axially translating internal ring. A set of crank arms on the forward end of the combustor case connects the internal ring to the external unison ring which is rotated by an appropriate actuation system. The outer crank arm shaft is inserted through the case bearing bushing into a splined connection with the inner crank arm and secured with a radial bolt. The bearing bushing is lined with low friction impregnated graphite on the ID and the inner flange face. The inner torque arms engage ball joint assemblies set in bosses on the OD of the translating ring to convert rotation of the unison ring into translation of the inner ring to move the nozzle plugs.

Figure 3-1 shows the fuel injectors and supports. Each of the 24 pre-mixing passages contains four fuel injectors each with two fuel injection holes at the injection plane spraying fuel toward the support struts for the air nozzle plug. These struts serve as splash plates or a filming surface if any atomized fuel droplets impinge on them.

Because of the importance that fuel spray quality plays in the vaporization process, the design of the fuel injector must be considered as a critical design item. The fuel injection system for Concept 1 represents an attempt to maximize the number of fuel source locations to obtain the highest possible degree of vaporization.

A dilution control device that meets the design objective of controlling a large quantity of airflow has been incorporated in the Concept 1 design. The design shown in Figure 3-1 utilizes a valving arrangement to bypass combustor inlet air at low power operation. The valve is closed during high power operation and can be partially open at part power to modulate the flow of bypass air. The valve consists basically of a conical ring which is translated axially by a set of crank arms around the combustor outer case. The outer arm of each set is connected to a unison ring rotated by an appropriate actuation device. To allow for tolerances and distortion, individual conical inserts are loosely attached to the conical ring by means of the rectangular spacers and retaining plates at each side of each insert. In operation, the conical ring moves rearward until the "high" points of the assembly engage. Inserts which are still loose are then forced into contact with their seats on the ends of the bypass ports by the combustor air pressure differential across the liner.

An analysis was conducted to determine if the 25 percent of combustor airflow available for cooling was sufficient to permit a conventional JT9D film cooled louver design with magnesium zirconate (MgZr) coating. A thermal analysis computer program was used to calculate surface temperatures for several IBZ equivalence ratios at the E³ SLTO condition. The Counter Parallel FINWALL[®] (CPFW) cooling scheme was also evaluated to assess the effects of an advanced cooling scheme on an LPP fuel combustor. Based on the results of this analysis which are presented in Section 4.1.1, CPFW was selected for this concept and all other concepts. CPFW is the most promising cooling scheme for E³ currently being developed by Pratt & Whitney Aircraft.

3.2.2 Concept Assessment

The results of a performance and emissions analysis for Concept 1 are summarized in Table 3-I and where applicable, the method of analysis applied to each parameter is discussed in detail below:

- o Pressure loss: the burner was sized to operate at a pressure loss of 5.5 percent at all operating conditions.
- o Combustion Efficiency:

The combustion efficiencies were estimated using an air loading correlation. In this correlation an air loading parameter (ALP) approach was applied to collected performance and emissions data from a large number of engines using annular combustors. Empirical curves of combustion efficiency as a function of ALP and equivalence ratio were plotted where:

$$ALP = \frac{3.72W_a}{p^{1.8} v 10^{0.000794} T}$$

W_a = Burner Air Flow
P = Burner Inlet Pressure
V = Burner Volume
T = Burner Inlet Temperature

- o Stability

The stability of concept 1 was assessed based on the empirical stability correlation of Ozawa (Ref. 15) and a study performed in-house on bluff body stabilization of premixed prevaporized flames. In Ref. 15 an empirical stability curve was generated by correlating data from a numerous different geometry flameholders. Figure 3-2 shows the predicted stability characteristics of concept 1 compared with experimental results for a similar 90° cone flameholder. The stability parameter of concept 1 was evaluated at the worst altitude relight condition estimated from JT9D informa-

TABLE 3-I
CONCEPT 1 DESIGN ANALYSIS

| <u>EMISSIONS</u> | | | |
|---|-------------|--------------------|----------------|
| | <u>Goal</u> | <u>Estimation*</u> | <u>Comment</u> |
| CO EPAP (g/kN) | ≤ 25.0 | 12 | |
| THC EPAP (g/kN) | ≤ 3.3 | 1.7 | |
| NO _x EPAP (g/kN) | ≤ 33.0 | ≤ 33.0 | |
| NO _x EI at CRUISE (g/kg fuel) | ≤ 3.0 | 3.1 to 3.9 | |
| Smoke Number | ≤ 20.0 | ≤ 10.0 | |

* Engine to engine variability not included in emission estimate.

| <u>PERFORMANCE</u> | | | |
|--|-------------|-------------------|--|
| | <u>Goal</u> | <u>Estimation</u> | <u>Comments</u> |
| Pressure Loss | ≤ 5.5% | ≤ 5.5% | |
| Combustion Efficiency | | | Based on ALP correlation |
| At Idle | ≥ 99.5% | ≥ 99.6% | |
| At Take Off | ≥ 99.9% | ≥ 99.9% | |
| At Other Operating Conditions | ≥ 99.0% | ≥ 99.0% | |
| Stability | | | Satisfactory |
| Autoignition | | | Safety factor of 2.5 applied. |
| Pattern Factor at Takeoff & Cruise | ≤ 0.25 | | Premix passage sizing and control critical. |
| Temperature Profile Factor at Takeoff & Cruise | ≤ 0.15 | | Premix passage sizing and control critical. |
| Maximum Combustor Liner Temperature | | | See analysis in Section 4.1.1 |
| Altitude Relight | ≥ 10.7 km | | Satisfactory |
| Starting | | | Satisfactory |
| Transient Behavior | | | Could be a problem. |

tion since windmilling flight characteristics for the E³ were not yet available. The predicted stability at the worst altitude relight condition was reassessed using the in-house stability study of the premixed prevaporized flames, as shown in Figure 3-3. The stability of concept 1 appears to be satisfactory in both correlations.

o Autoignition:

Autoignition time was estimated based on the design curve of Ref. 7. In Ref. 7, a number of autoignition data for JP fuels were displayed on an Arrhenius plot, and a design limit line was drawn to allow a safety factor of about 2.5. The plot is shown in Figure 3-4. Based on the design limit, the autoignition delay time is evaluated to be 0.8 Msec. at the E³ SLTO condition and 3.1 Msec. at the cruise condition.

o Emission Estimates:

CO and THC emissions were estimated from the combustion efficiency correlation described above. A CO to THC ratio of 7 to 1 at idle was assumed based on several prior experimental emissions programs. CO and THC were then back-calculated from the efficiency relationship.

$$\eta_c = 100 - 100 \frac{4343 (\text{CO}) + 21500 (\text{HC})}{18.4 \times 10^6}$$

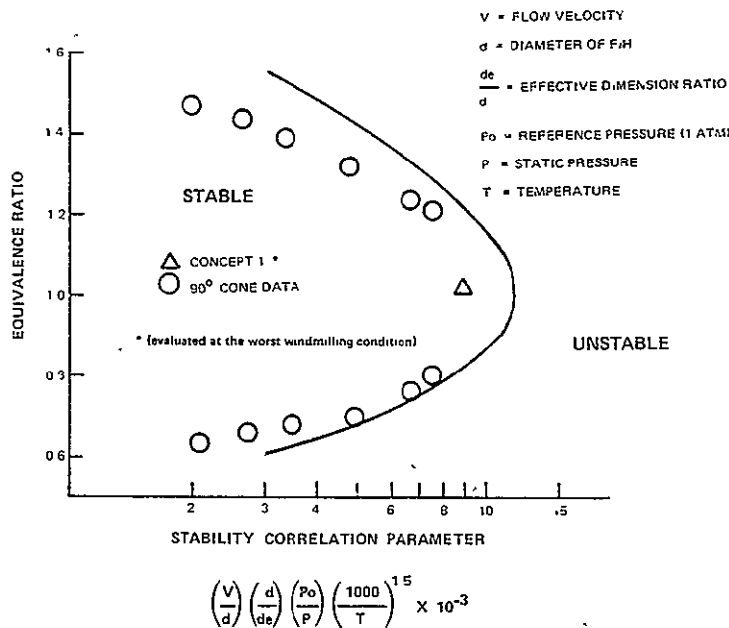

Figure 3-2 Flame Stability Curve

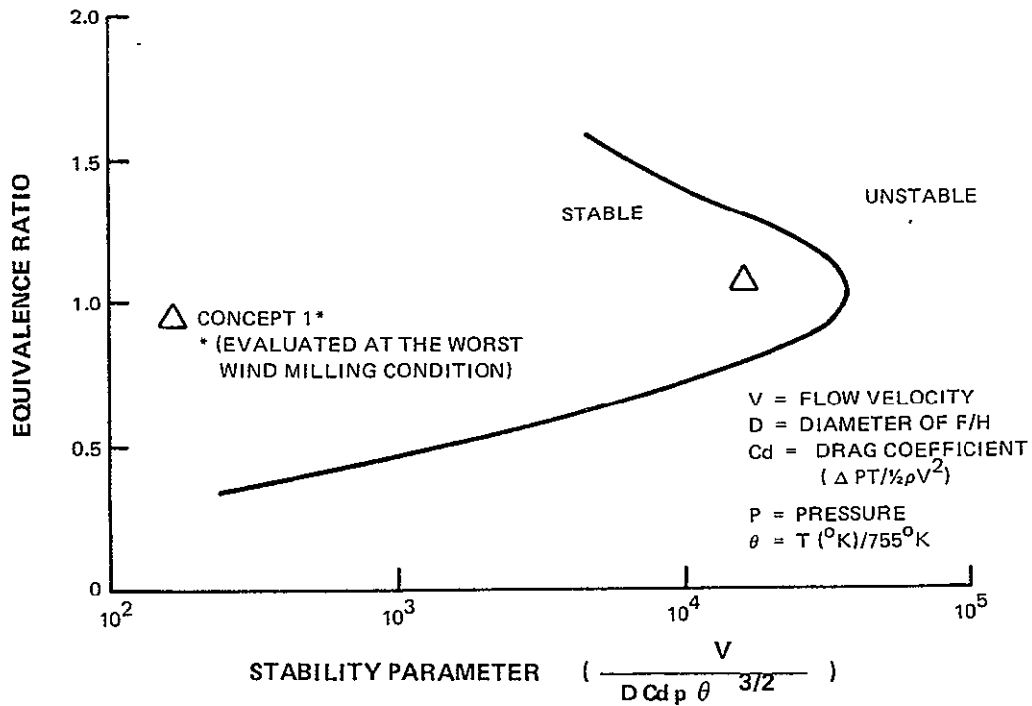

Figure 3-3 Stability Correlation Curve

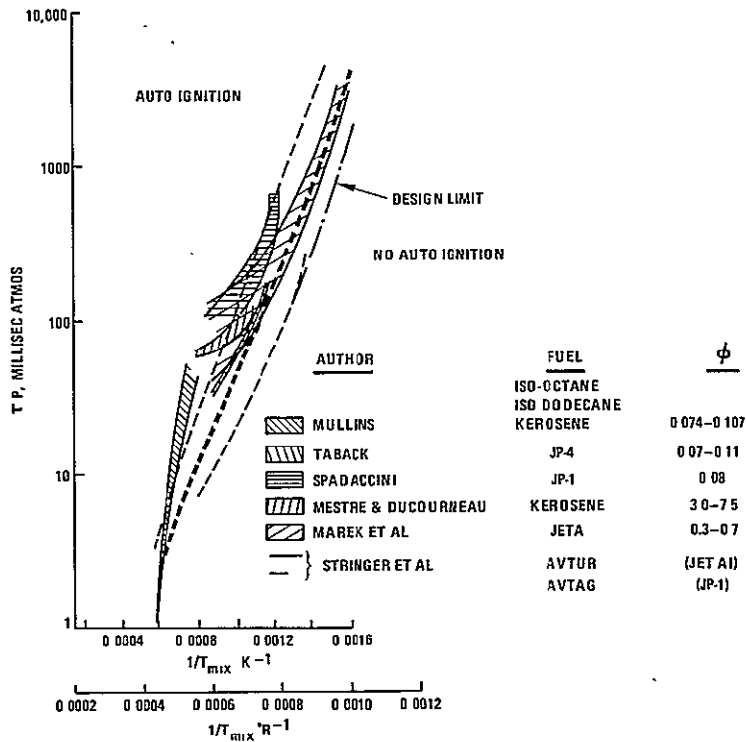

Figure 3-4 Autoignition of Liquid Hydrocarbon Fuel Sprays in Air

Although the ability to estimate emissions in this manner is questionable, past experience has shown that most combustors can achieve very low CO and THC emissions if operated at a high IBZ equivalence ratio at idle. Since variable geometry air staging provides the ability of richening the primary zone to desired levels, achieving the low power emission goals should be possible.

Although significant research has been conducted in the area of NO_x formation in homogeneous premixed flames, Refs. 2 and 16, the ability to accurately predict NO_x emissions in an engine environment requires some knowledge on the effect of non-homogeneity resulting from incomplete vaporization and mixing. In the present study, NO_x emissions at cruise were estimated by two methods, the first used data generated in a recent NASA program, Ref. 17, to account for the effect of incomplete vaporization. Using data from this study a NO_x EI at cruise of 3.1 was predicted for the Concept 1 configuration operating at approximately 70 percent vaporization.

The effect of the incomplete vaporization was also estimated by comparing the results obtained with a premix burner design that was evaluated in a Pratt & Whitney Aircraft engine test program (Ref. 13). In the reference program the combustor premix passage was operated at an equivalence ratio of approximately 0.65 and a calculated vaporization of 45 percent. By assuming that the difference between the measured NO_x and the predicted value for 100 percent vaporization and perfect mixing was due to the unvaporized fuel, an estimate was made of the emissions for the Concept 1 configuration operating at 70 percent vaporization with some droplet burning. At the cruise condition the NO_x emissions index was estimated at 3.9 using this approach.

Since this second estimate is based on actual engine data, it is probable that the higher value is the result of poor fuel/air preparation. It is likely that the value for the Concept 1 configuration when tested at E³ condition will be somewhere in between.

- o Smoke Level

Based on previous in-house programs with premixed combustors, smoke should be well below the goal value.

- o Altitude Relight and Starting:

Both of these operational requirements are difficult to assess for this new front end design. Ignitor location will be critical and the optimum ignitor location for good relight and starting should be determined through testing.

- o **Transient Behavior:**

This is considered a critical area in LPP variable geometry design. The very lean IBZ ϕ at high power operation makes the designs susceptible to lean blowouts on snap decels. In addition, snap accelerations may cause unanticipated problems such as flashback in the combustor system. Since it is not easy to conduct transient testing, burner stability should be evaluated at steady state off-design conditions to investigate transient behaviors.

- o **Exit Temperature Pattern Factor**

A significant side benefit of lean premixed combustion is a reduction in the potential for hot streaks and, hence, improved pattern factor. The Concept 1 configuration will require careful premix passage and control system design since any induced variations in airflow through the individual passages will affect pattern factor. Furthermore, with 65 percent of the combustor airflow entering through the premix passages, new techniques will be required for tailoring exit temperature radial profile with the remaining small amount of dilution air available.

3.3 CONCEPT 2

3.3.1 Concept Description

The second concept, shown in Figure 3-5, employs fuel staging in addition to variable geometry in an attempt to improve transient stability. Basically the design consists of 24 premixing tubes, each with concentric inner and outer fuel/air mixing passages. The inner passage, which has fixed geometry and is supplied with fuel through an aerating nozzle, serves as the pilot stage while the outer annular passage, which is equipped with a variable geometry sleeve, serves as the main stage. Swirling flows generated within each passage act to enhance vaporization and mixing of the fuel air mixture and also stabilizes the flame in the combustion zone. The concept is based on a design that demonstrated significant reduction in high power NO_x emissions in Pratt & Whitney Aircraft IR&D low emissions program. Variable geometry was simulated in back-to-back emissions tests by using blockage rings to modulate outer passage airflow. The results of that testing are presented in Section 3.3.2, where emissions estimates for Concept 2 are discussed.

Figure 3-5 Variable Geometry IPP Combustor - Concept 2

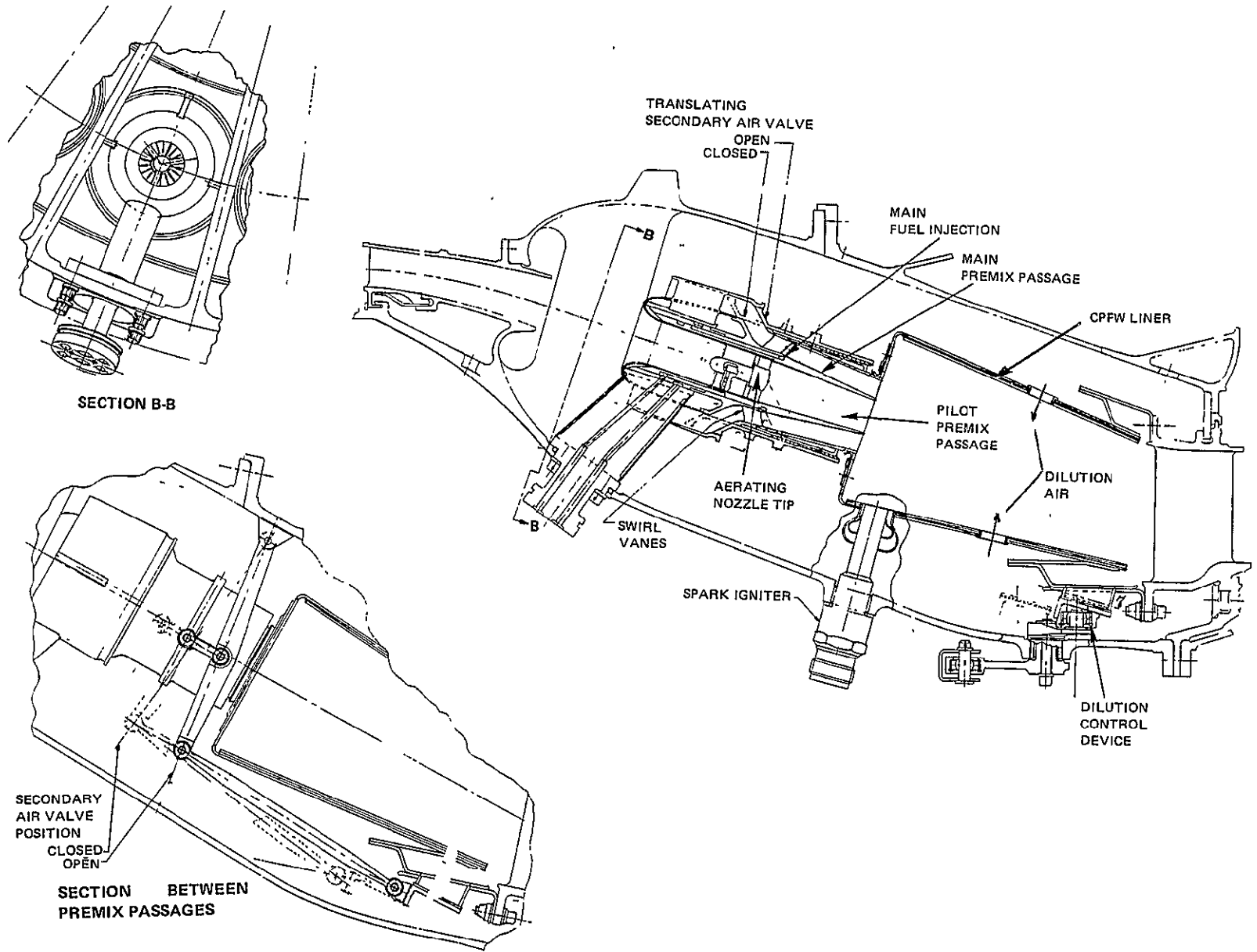

A preliminary fuel schedule for the pilot and main stage for Concept 2 is presented in Figure 3-6. As shown, the fuel and air schedules are adjusted for stoichiometric combustion at idle for high combustion efficiency and low levels of THC and CO while lean conditions are maintained at high power to reduce flame temperature and limit NO_x production. At idle, fuel and air are supplied through only the inner passage while the outer passage is closed off to both except for a small amount of purge air to prevent recirculation of combustion gases into the tube. At the approach condition both inner and outer passages are fueled with the majority of fuel still supplied through the inner passage. At this condition, passage airflow is low to keep the equivalence ratio sufficiently high for good CO and THC emissions. At the high power conditions most of the fuel is supplied through the outer tube and the air passage is near full open such that the equivalence ratio will be close to the desired 0.55. During high power operation, the primary zone equivalence ratio will be maintained above 0.55 to provide protection against lean blowouts during snap deceleration. Since the percentage of fuel supplied through the pilot is low at these conditions, the pilot contribution and hence the increase in overall NO_x level will be small.

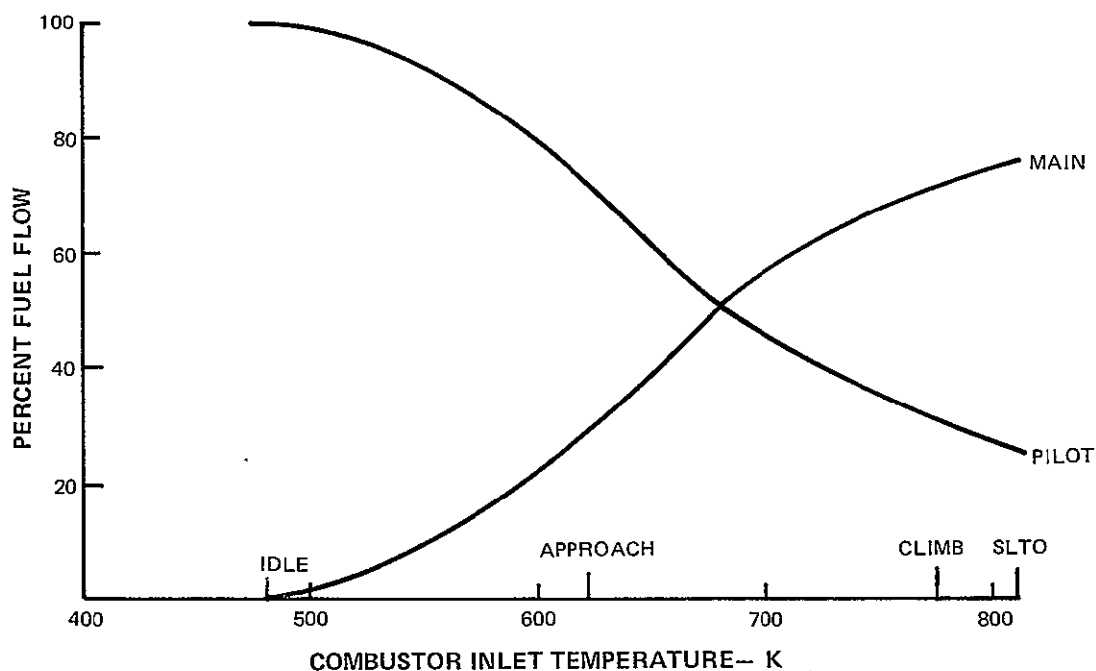

Figure 3-6 Preliminary Fuel Schedule for Concept 2

As shown in Figure 3-5 heat shields surround the support structure of the premix tube assemblies and provide an aerodynamic ram inlet fairing for the primary and secondary air inlets. The central primary air tube contains an aerating nozzle and swirl vane assembly supported by three struts. Primary and secondary fuel passages in the main support strut feed circular manifolds.

The secondary ram air inlet hood is supported by the main strut and by three short struts. An axially sliding sleeve with a conically diverging forward end opens and closes the circumferential secondary mixing tube inlet. Eighteen swirl vanes also support the outer secondary mixing tube and the cylinder on which the graphite liner for the sliding sleeve is mounted. The aft end of the secondary mixing tube engages a sliding seal which permits axial and radial displacements of the premix tube assemblies relative to the combustor front bulkhead.

Actuation of the sliding sleeves is provided by the ball jointed linkages shown in the figure, which are connected to the exit bypass valve ring. External actuation of the circumferential unison ring rotates 12 crank arm assemblies to provide axial translation of the exit valve ring. The linkage is designed so that the secondary air premix tube valve is open when the exit bypass valve is closed and vice versa.

Two ignitors are provided. Their final axial and circumferential locations can only be determined during a test program. Axial support of the combustor is provided at the aft end of the inner liner, with a sliding joint at the end of the outer liner. Brackets may be added at the front end of the outer liner to engage case mounted radial pins similar to the design for Concept 1 should the need arise.

The Concept 2 design incorporates the same dilution control device as described for Concept 1 in Section 3.2.1.

3.3.2 Concept Assessment

The assessment of the Concept 2 design is summarized in Table 3-II. Except for the expected improvements to stability by the addition of a pilot fuel stage, the performance characteristics of Concept 2 are essentially the same as for Concept 1. The discussion of these items presented in Section 3.2.2 for Concept 1, therefore, applies to Concept 2. This section will concentrate on the emission estimates for Concept 2.

Emission Estimates

The emission levels predicted for Concept 2 were estimated from the results of a Pratt & Whitney Aircraft rig test program directed at evaluating the configuration from which Concept 2 has been modeled. Variable geometry was simulated by utilizing blockage rings in back-to-back rig tests to vary the airflow through an outer passage which served as the main combustor stage. At idle conditions, fuel and air were supplied through just the inner pilot stage, while at high power condition, the blockage rings were removed and both the inner and outer passages were fueled. Although testing during this program was limited in scope, the results did demonstrate the excellent potential of this concept toward NO_x emission reduction.

TABLE 3-II

CONCEPT 2 DESIGN ANALYSIS

EMISSIONS

| | <u>Goal</u> | <u>Estimation*</u> | <u>Comment</u> |
|---|-------------|--------------------|---|
| CO EPAP (g/kN) | ≤ 25.0 | 24.0 | Significant reduction should result with aerating pilot nozzle. |
| THC EPAP (g/kN) | ≤ 3.3 | 0.5 | |
| NO _x EPAP (g/kN) | ≤ 33.0 | ≤ 33.0 | |
| NO _x EI at Cruise (g/Kg fuel) | ≤ 3.0 | 2.4 | |
| Smoke Number | ≤ 20.0 | ≤ 10.0 | |

* Engine to engine variability not included in emission estimate.

PERFORMANCE

| | <u>Goal</u> | <u>Estimation</u> | <u>Comments</u> |
|--|-------------|-------------------|---|
| Pressure Loss | ≤ 5.5% | ≤ 5.5% | |
| Combustion Efficiency | | | Based on ALP correlation |
| At Idle | ≥ 99.5% | ≥ 99.6% | |
| At Takeoff | ≥ 99.9% | ≥ 99.9% | |
| At Other Operating Conditions | ≥ 99.0% | ≥ 99.0% | |
| Stability | | | Satisfactory |
| Autoignition | | | Safety factor of 2.5 applied. |
| Pattern Factor At Takeoff & Cruise | ≤ .25 | | Premix passage sizing and control critical |
| Temperature Profile At Takeoff & Cruise | ≤ .15 | | Premix passage sizing and control critical |
| Maximum Combustor Liner Temperature | | | See analysis in Section 4.1.1 |
| Altitude Relight | ≥ 10.7 Km | | Satisfactory |
| Starting | | | Satisfactory |
| Transient Behavior | | | Pilot zone should be beneficial at both steady state and transient operation. |

The low power emissions obtained at various IBZ equivalence ratios are shown plotted in Figures 3-7 while high power NO_x emissions are shown plotted in Figure 3-8. When extrapolated to E³ operating conditions, THC and NO_x emissions meet the program goals while CO exceeds the goal as shown in the table. The incorporation of an aerating pilot nozzle in the Concept 2 design should reduce CO levels by reducing droplet size and improving fuel air preparation. Other results obtained in the rig program were a demonstrated smoke number of 6 at the design SITO condition and the fact that CO and THC emissions were very low at high power conditions. Quite often low NO_x levels at high power conditions are compromised by high CO and THC levels which can be construed as a sign of impending instability.

3.3.3 Concept 2 Adaptation to JT9D

3.3.3.1 Concept Description

The adaptation of the concept 2 design to the JT9D engine is shown in Figure 3-9. Although the two designs are very similar, the lower high power operating temperatures and pressures of the JT9D engine allow an expanded premix passage length which should benefit vaporization and mixing of fuel and air. The lower combustor inlet temperatures and pressures also permit the conventional film cooling louver with MgZr coatings to be employed as a liner cooling scheme. The number of premix passages was also changed from 24 to 20 to be compatible with the 10-strut design of the JT9D engine. Except for these modifications the description presented earlier in section 3.3.1 for the E³ design is applicable.

3.3.3.2 Concept Assessment

The performance and mechanical/operational characteristics of the two engine designs were judged to be essentially the same and the discussion presented in section 3.3.2 for the E³ design applies for the JT9D adaptation. This section will concentrate on the differences in estimated emissions between the two designs.

Emission Estimates

A comparison of the estimated emission and smoke levels for the two engine designs is presented in Table 3-III. As shown, the JT9D design should produce significantly lower NO_x emission at the cruise condition chiefly due to the reduced operating pressure and temperature. At low power condition the reduced temperature and pressure would result in a slight increase in both CO and THC emission levels. The large increases shown in the table is mostly the result of the differences in EPAP coefficients, the E³ being 50 percent less due to an improved idle engine efficiency. Smoke for both designs should be well below the goal levels.

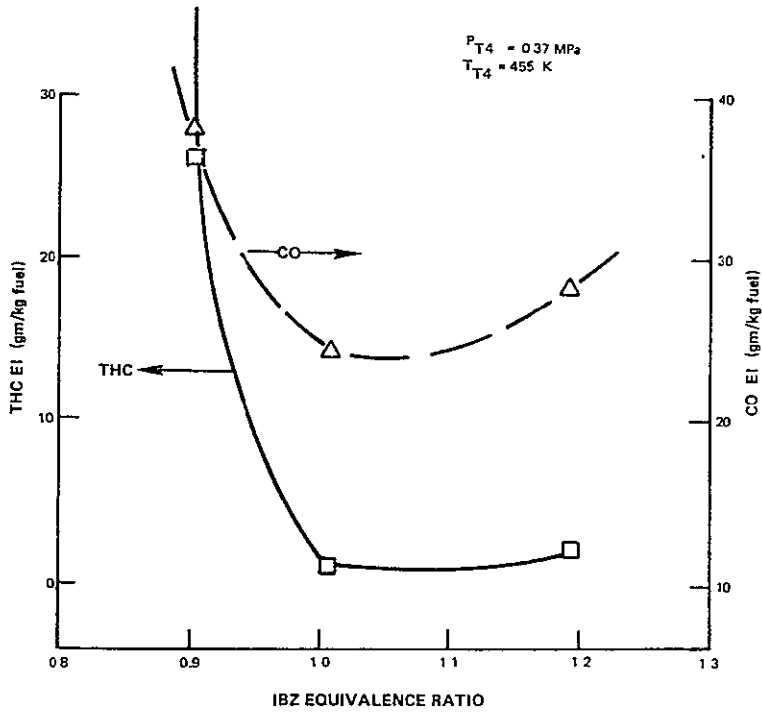

Figure 3-7 CO and THC Emissions at Idle for Various IBZ Equivalence Ratios

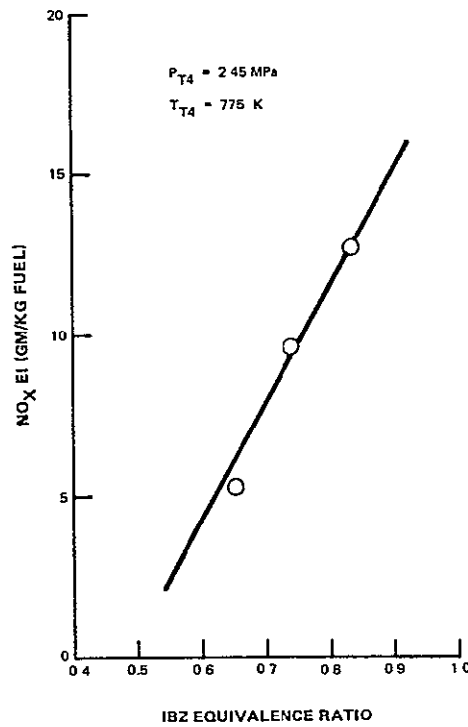
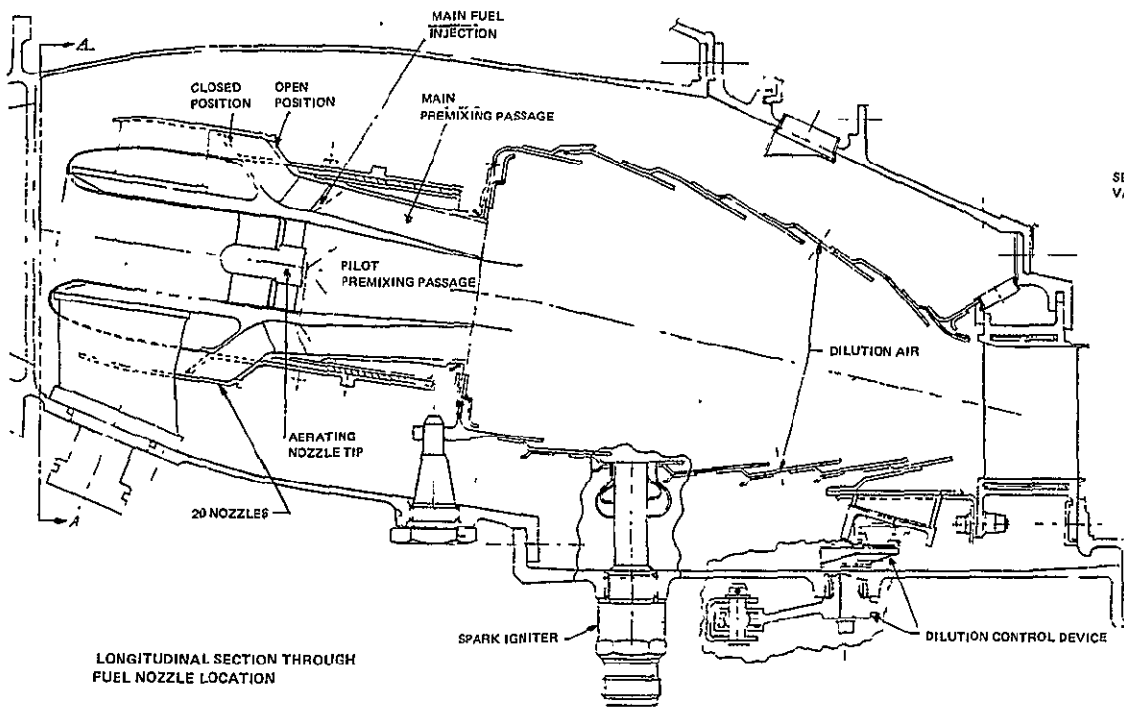
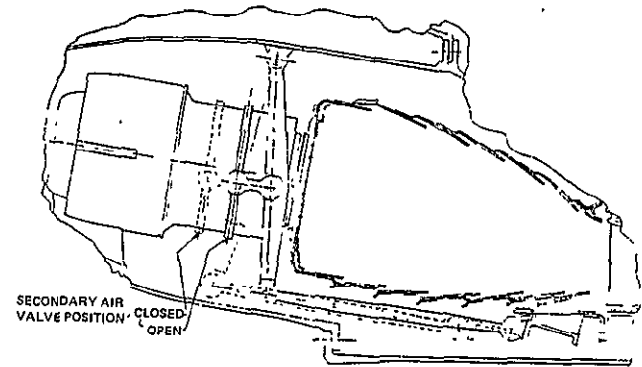

Figure 3-8 NO_x Emissions at SLTO for Various IBZ Equivalence Ratios



LONGITUDINAL SECTION THROUGH FUEL NOZZLE LOCATION



SECONDARY AIR VALVE POSITION: CLOSED OPEN

LONGITUDINAL SECTION BETWEEN FUEL NOZZLES

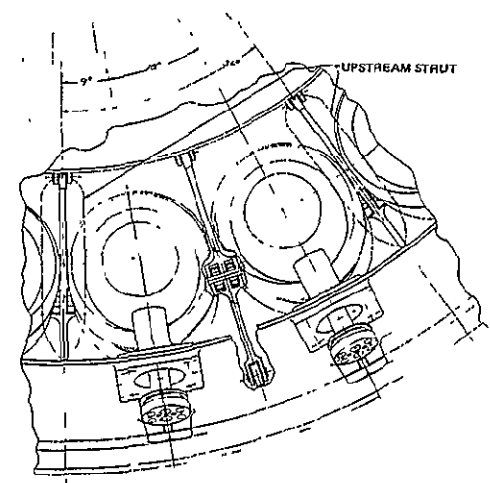

SECTION A A

Figure 3-9 Concept 2 Adapted to JT9D Engine

TABLE 3-III
COMPARISON OF CONCEPT 2 EMISSION ESTIMATES
FOR E³ AND JT9D ENGINE APPLICATION

| <u>Emission Estimate*</u> | <u>E³</u> | <u>JT9D</u> | <u>Goal</u> |
|---|--------------------------|------------------------|-------------|
| Cruise NO _x EI (g/kg fuel) | 2.4 (13.8 atm. 754 K) | 1.7 (10 atm. 710 K) | ≤ 3.0 |
| CO EPAP (g/kN) | 24 | 43 | ≤ 25.0 |
| THC EPAP (g/kN) | 0.5 | 0.9 | ≤ 3.3 |
| Smoke | ≤ 10 | ≤ 10 | ≤ 20 |

* Engine-to-engine variability not included in emission estimate.

3.4 CONCEPT 3

3.4.1 Concept Description

The Concept 3 configuration as shown in Figure 3-10 is a radially staged burner design incorporating an aerated nozzle fueled, swirl stabilized pilot zone, located inboard and upstream of a premixed/pre-vaporized main zone. The main zone premix passage is separated into 24 compartments that occupy approximately 70 percent of the available burner inlet circumferential area. The remaining area between passages is used for structural support to allow a free floating flameholder design.

Several flameholder types were evaluated before selecting the V-gutter design presented in Figure 3-10. Each compartment contains four individual V-gutters that are free to expand in the longitudinal direction in order to minimize stresses and distortions. The size and spacing within each compartment were selected from the results of a previous NASA program, Ref. 12, in which a conical V-gutter flameholder was evaluated for stability and emissions. Forty-eight pressure atomizing fuel nozzles mounted on the primary nozzle supports supply the main zone with fuel.

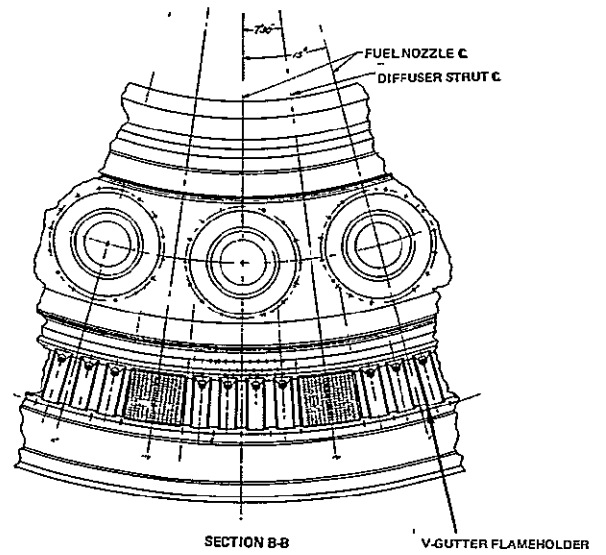
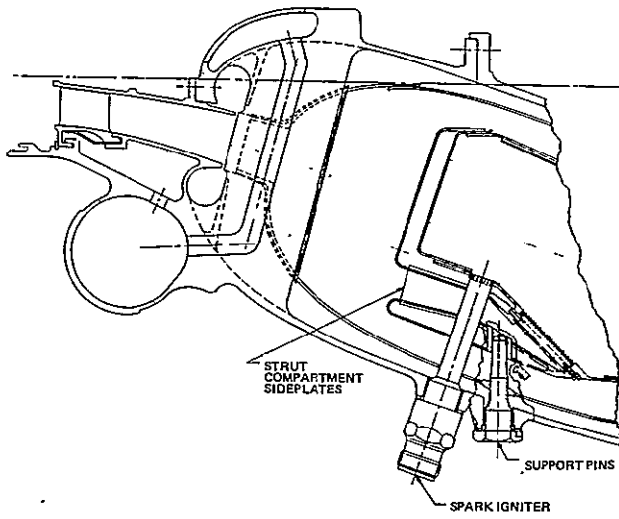
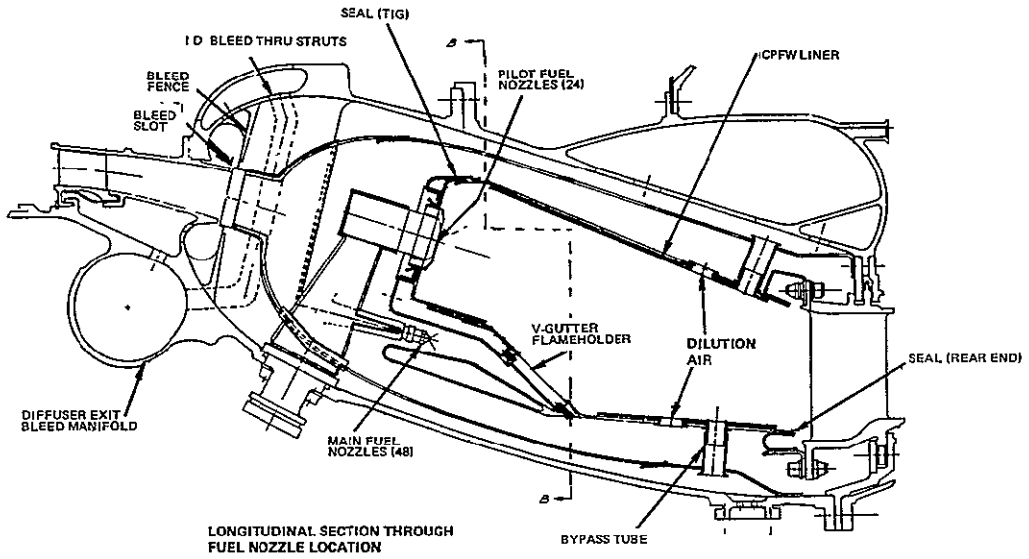

Figure 3-10 LPP Combustor - Concept 3

The concept differs from the previous designs in the method in which front end airflow and stoichiometry are controlled. Instead of a mechanical type of area modulation diffuser wall bleeding is used to vary the inlet air velocity profile. Both inner and outer wall bleeds are used to divert airflow from the burner front end at only the approach condition. The design is based on a variable geometry combustor evaluated as part of a research program directed at determining the feasibility of controlling exhaust emissions in a purely aerodynamic manner, Ref. 18. How the airflow is modulated by bleeds is schematically shown in Figure 3-11. The vortex formed by bleeding acts in the manner of a roller bearing, guiding flow to bypass the front end smoothly over a sudden step. Without bleeds the airflow ignores the step and leaves the diffuser as a high velocity jet.

Prior to adopting this system an analytical investigation was conducted to evaluate a more simple approach of controlling velocity profile with diffuser bleed alone. The feasibility of a simple aerodynamic control to modulate airflow distribution was studied using the computer flow calculation deck (TEACH), which handles two-dimensional incompressible viscous flow. Bleed was applied to a 2-D sudden expansion flow and parametrically run changing the bleed flow rate, and position. Study results indicate that without downstream blockage, bleeding can change airflow distribution but modulation is limited to off/on, and that the flow is not sensitive to the position of bleed. The analysis was repeated with downstream blockage simulating a combustor in size and location. With the blockage diffuser bleeding was not successful in shifting airflow significantly regardless of bleed position or flow rate. Hence the more complex system tested and reported in Ref. 18 was adopted.

3.4.2 Concept Assessment

The assessment of the concept 3 design is summarized in Table 3-IV. Except for an improvement in mechanical complexity/reliability resulting from the absence of any area modulation hardware, the performance and operational characteristics of concept 3 are essentially the same as for concept 1. The discussion of these items presented in Section 3.2.2 therefore applies. This section will concentrate on the emission estimates for concept 3.

Emission Estimates

During the preliminary analysis of concept 3 it was evident that the degree of front end airflow modulation available with a diffuser bleed control was critical in estimating emission levels. The analysis was therefore conducted for three different values of airflow diverted from the combustor front end. Specifically values of 25, 40 and 50 percent were considered even though most of the test data in Ref. 18 indicated that a maximum of 25 percent diffuser airflow could be diverted with 7 percent bleeds.

TABLE 3-IV
CONCEPT 3 DESIGN ANALYSIS

| <u>Emissions</u> | | | |
|---|-------------|--------------------|----------------|
| | <u>Goal</u> | <u>Estimation*</u> | <u>Comment</u> |
| CO EPAP (g/kn) | ≤ 25.0 | 21 | |
| THC EPAP (g/kn) | ≤ 3.3 | 3.9 | |
| NO _x EPAP (g/kn) | ≤ 33.0 | < 33.0 | |
| NO _x EI at Cruise (g/kg fuel) | ≤ 3.0 | 30 | |
| Smoke Number | ≤ 20 | < 10 | |

* Engine to engine variability not included in emission estimate.

| <u>Performance</u> | | | |
|--|-------------|-------------------|--|
| | <u>Goal</u> | <u>Estimation</u> | <u>Comment</u> |
| Pressure Loss | ≤ 5.5% | ≤ 5.5% | Based on ALP correlation |
| Combustion Efficiency at Idle | ≥ 99.5% | ≥ 99.7% | |
| at Takeoff | ≥ 99.9% | ≥ 99.9% | |
| at Other Operating Conditions | ≥ 99.0% | ≥ 99.0% | |
| Stability | | | Satisfactory |
| Autoignition | | | Safety factor of 2.5 applied |
| Pattern Factor at Takeoff and Cruise | ≤ 0.25 | | Premix passage sizing and control critical |
| Temperature Profile Factor at Takeoff and Cruise | ≤ 0.15 | | Premix passage sizing and control critical |
| Maximum Combustor Liner Temperature | | | See analysis in Section 4.1.1 |
| Altitude Relight | ≥ 10.7 Km | | Satisfactory |
| Starting | | | Satisfactory |
| Transient Behavior | | | Could be a problem |

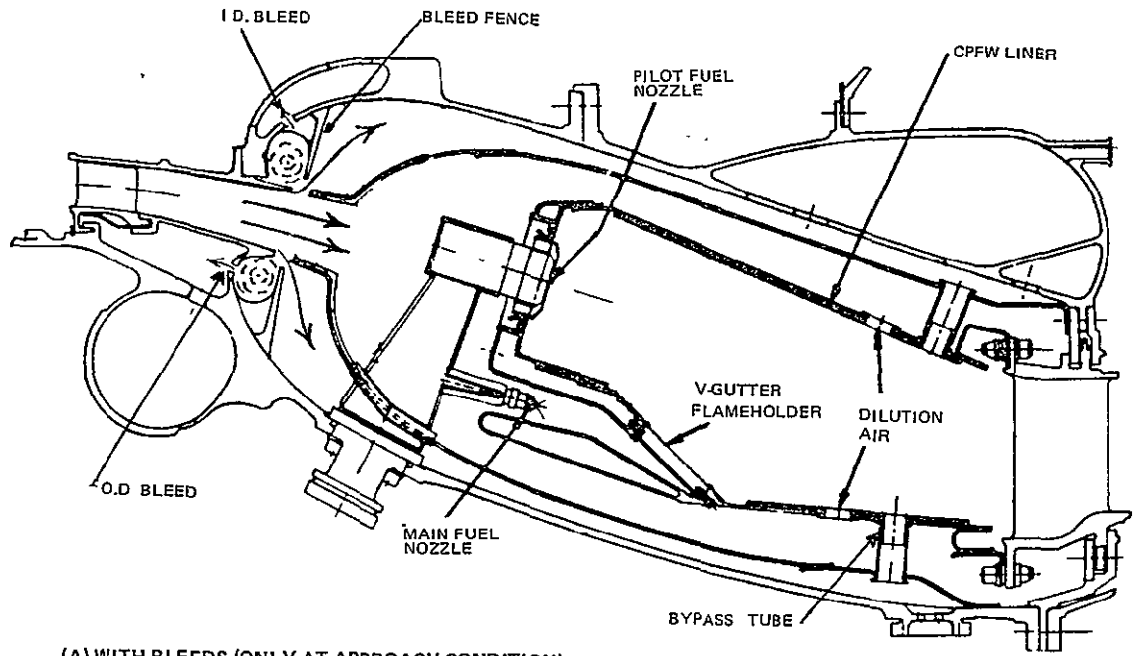

(A) WITH BLEEDS (ONLY AT APPROACH CONDITION)

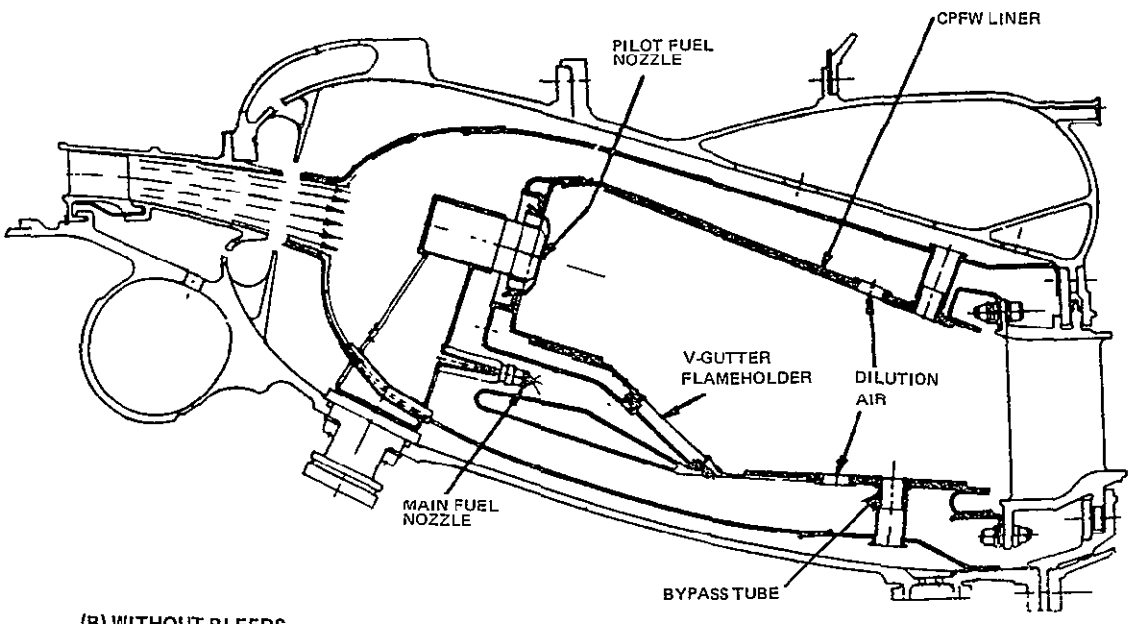

(B) WITHOUT BLEEDS

Figure 3-11 Schematic of Airflow Modulation by Bleeds

The flow distribution within the combustor was determined by setting the equivalence ratio at approach with bleed sufficiently high to ensure a combustion efficiency of 99.0 percent. The test results from previous emission program (Ref. 13) presented in Figure 3-12, were used in establishing a value of 0.70 at approach. The unbled equivalence ratios at cruise were then back-calculated for each bleed condition being analyzed and NO_x emission levels at cruise were estimated following the same theoretical procedure used for concept 1 and described in Section 3.2.2. The results of the analysis are presented in Table 3-V and as shown, unless a very high percentage of flow can be diverted, this method does not have much potential for NO_x reduction.

CO and THC emissions at idle and approach were estimated from the efficiency correlation described in Section 3.2.2. For this concept the approach contribution to the CO and THC EPAP were significant.

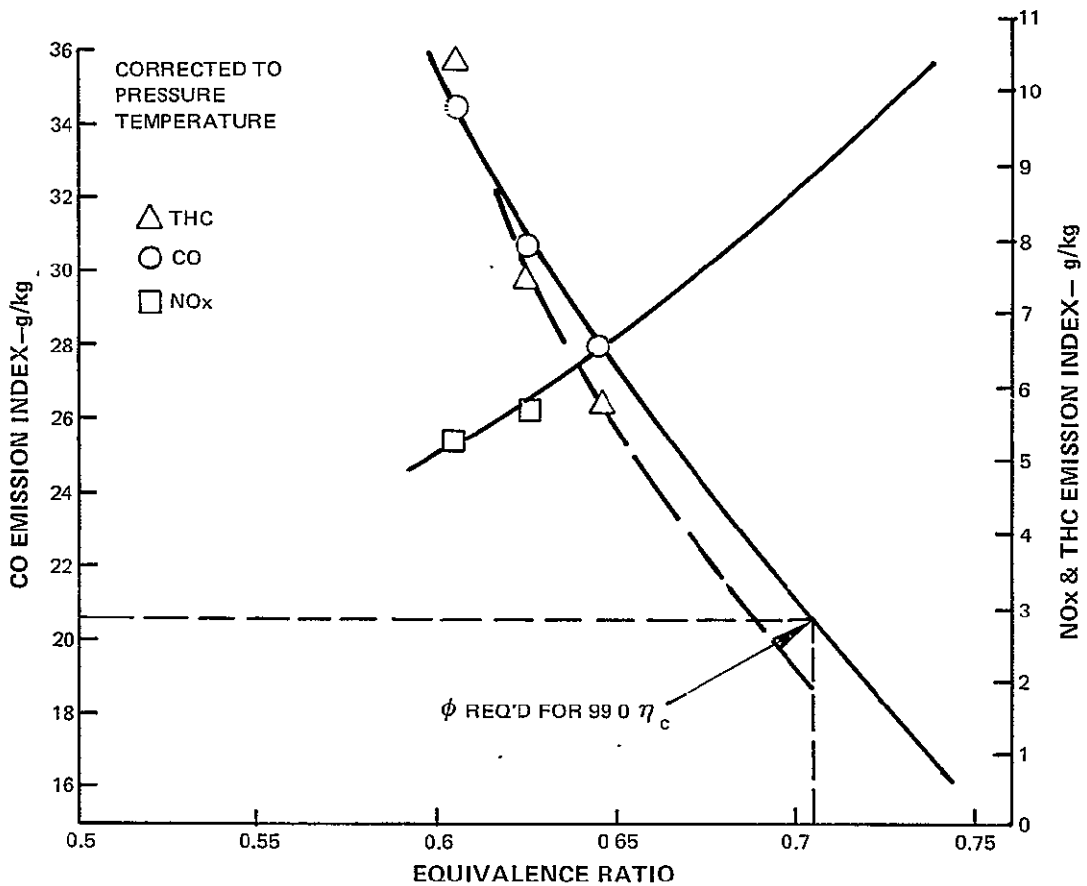

Figure 3-12 Emissions Estimates for Concept 3

TABLE 3-V
ESTIMATED NO_x EMISSIONS AT CRUISE

| Front End Flow Diversion % | Equivalence Ratio Cruise Unbled | NO _x Cruise EI g/kg |
|----------------------------------|---------------------------------------|--------------------------------------|
| 25 | 0.89 | 30 |
| 40 | 0.70 | 11.7 |
| 50 | 0.59 | 4.8 |

3.5 CONCEPT 4

3.5.1 Concept Description

The fourth concept shown in Figure 3-13 was patterned after a promising design developed during the Catalytical Combustor Program, Ref. 7. Valves located in the combustor OD shroud area are used to modulate airflow between the primary and dilution zones to allow stoichiometric burning at idle for high combustion efficiencies and low levels of CO and THC, and very lean combustion at high power conditions for reduced NO_x emission levels.

The size and location of the air control valves introduced several mechanical design problems. Physical size restraints required both an outward expansion of the burner case to accommodate the valve assembly and a recontouring of the diffuser to provide an aerodynamically clean feed to the valve inlet tubes. Furthermore, the resultant "one sided" combustor could introduce penetration and mixing deficiencies that would adversely effect both emission and exit temperature distribution. Providing additional air control valves in the ID shroud area was considered as a possible fix, but since it would result in a drastic increase in complexity without eliminating the physical size problems it was not incorporated in the design.

In the concept 4 design the two valves are mounted on the same drive shaft to ensure simultaneous control of primary and dilution zone airflows. At the idle condition the inner valves are closed and the outer ones are open. This prevents air entering the primary zone through the side ports allowing stoichiometric burning for high combustion efficiencies and low levels of CO and THC. At high power conditions the outer valves are closed and the inner ones are open, allowing the combustion air to enter through the side ports, providing very lean combustion for reduced NO_x emission levels.

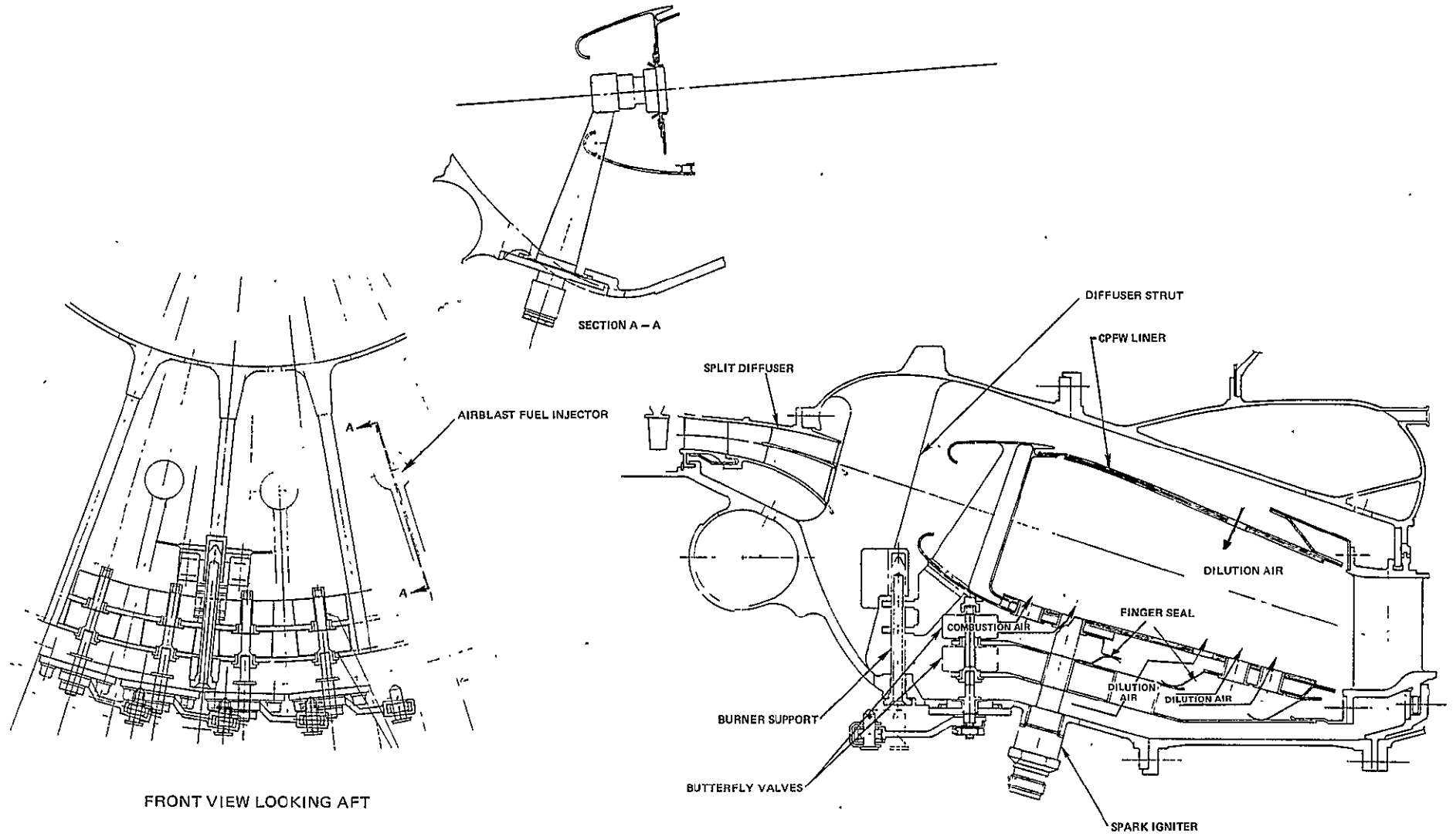

Figure 3-13 LPP Combustor - Concept 4

A split diffuser is used to give the desired flow split between ID and OD shroud. To ensure adequate cooling of the front end combustor outer liner at all conditions, cooling airflow is provided by double wall construction, with the resultant annulus feed from inside the hood. A separate annulus passage is provided between the outer valves and the outer diffuser case to supply both cooling air necessary for the combustor outer liner aft section and dilution air for temperature distribution control. The outer contour of the Energy Efficient Engine diffuser case was modified to incorporate the variable geometry and three independent annulus air passages in the OD shroud area. Twenty four airblast fuel injectors are provided in a conventional, externally removable arrangement, as shown in Figure 3-13 (section A-A). The number of valves (96, 48 inner valves and 48 outer valves) and the number of fuel injectors (24) were selected for compatibility with the 24- strut design of the Energy Efficient Engine.

3.5.2 Concept Assessment

The assessment of the concept 4 design is summarized in Table 3-VI. Except for pattern factor and radial temperature profile which are considered worry items with the concept 4 design, the performance and operational characteristics of Concept 4 have been judged the same as those for concept 1 and the discussion in Section 3.2.2 is applicable. This section will concentrate on the emissions estimates.

Emissions Estimate

CO and THC emissions for concept 4 were estimated from the combustion efficiency method described for concept 1 in Section 3.2.2. The estimated values were then compared to results obtained with a low emission JT9D-7 combustor being developed at Pratt & Whitney Aircraft. The low emissions combustor which serves to provide backup data support to the calculation procedure employs a bulkhead type front end containing aerated fuel nozzles similar to those for Concept 4. The results from an experimental JT9D-7 engine program corroborate the calculated values for concept 4 tabulated in Table 3-VI.

NO_x emissions were estimated based on an assumed 50 percent variation in IBZ equivalence ratio due to poor mixing and were calculated from pollutant measurements taken from partially mixed turbulent flames during a flame tube study at Pratt & Whitney Aircraft (Ref. 19).

Based on previous in-house programs with premixed combustors and experience with the JT9D-7 low emissions combustor, smoke should be well below the goal.

TABLE 3-VI
CONCEPT 4 DESIGN ANALYSIS

| <u>EMISSIONS</u> | | | |
|---|-------------|--------------------|---|
| | <u>Goal</u> | <u>Estimation*</u> | <u>Comment</u> |
| CO EPAP (g/kN) | ≤ 25.0 | 12.0 | |
| THC EPAP (g/kN) | ≤ 3.3 | 1.7 | |
| NO _x EPAP (g/kN) | ≤ 33.0 | 24 | |
| NO _x EI At Cruise (g/kg Fuel) | ≤ 3.0 | 7.5 | NO _x emission will depend on the degree of mixedness. This estimate is based on 50% variation in IBZ equivalence ratio due to poor mixing. |
| Smoke Number | ≤ 20.0 | ≤15.0 | |

* Engine to engine variability not included in emission estimate.

| <u>PERFORMANCE</u> | | | |
|--|-------------|-------------------|---|
| | <u>Goal</u> | <u>Estimation</u> | <u>Comments</u> |
| Pressure Loss | ≤5.5 | ≤5.5% | |
| Combustion Efficiency | | | Based on ALP correlation |
| At Idle | ≥ 99.5% | ≥99.7% | |
| At Takeoff | ≥ 99.9% | ≥99.9% | |
| At Other Operating Conditions | ≥ 99.0% | ≥99.0% | |
| Stability | | | Satisfactory |
| Autoignition | | | Safety factor of 2.5 applied. |
| Pattern Factor At Takeoff & Cruise | ≤0.25 | | One sided combustion will require evaluation at test. |
| Temperature Profile Factor at Takeoff & Cruise | ≤0.15 | | One sided combustion will require evaluation at test. |
| Maximum Combustor Liner Temperature | | | See analysis in Section 4. |
| Altitude Relight | ≥10.7 Km | | Satisfactory |
| Starting | | | Satisfactory |
| Transient Behavior | | | Could be a problem. |

4.0 ENGINE FEASIBILITY CRITERIA

Aircraft engine component design, as opposed to conceptual design studies, requires that criteria in addition to those of emissions and performance already discussed be considered as well. Specifically, factors such as mechanical integrity, reliability, weight, cost and time to develop are also prime considerations. Although it was beyond the scope of this conceptual design study program to develop designs in sufficient detail to permit an accurate assessment of these factors, estimates of the relative strengths and weaknesses of the four concepts were made and are presented in the following sections.

4.1 MECHANICAL INTEGRITY/RELIABILITY

This section includes a comparative analysis of combustor hardware temperatures and reliability characteristics of each design.

4.1.1 Thermal Analysis

This section presents an analysis conducted to determine if the 25 percent of combustor airflow available for cooling was sufficient to permit a conventional JT9D film cooled louver design with magnesium zirconate coating. A thermal analysis computer program was used to calculate surface temperatures on each concept for several IBZ equivalence ratios at the E³ SLTO condition. The Counter Parallel FINWALL^R (CPF_W) cooling scheme was also evaluated on concept 1 to assess the effects of an advanced cooling scheme on an LPP fuel combustor. The results of this analysis are shown in Figure 4-1. The figure shows that the surface temperatures of concepts 1 and 2 are below the desired maximum temperature of 1150K (1600°F) at the design high power equivalence ratio of 0.55 if uniform (premixed) combustion is achieved, while concept 3 and 4 are slightly over the desired surface temperature. The prediction also shows that the surface temperatures for CPF_W cooling are about 100K cooler than the film cooled louver temperatures of concept 1.

4.1.2 Reliability

Each of the four conceptual designs was reviewed and analyzed relative to its potential impact on engine reliability. Previous combustor and engine component hardware reliability experience was used as the criterion for judging the relative importance of the major LPP fuel combustor features. Reliability may be expected to be the inverse of the complexity of the total combustor system, with reduced reliability associated with movable components. The three major features considered in order of importance were:

1. Mechanical Linkages:

- o Quantity - the more joints the more likelihood of binding.
- o Location - support at the burner front end is considered structurally weaker than support by the outer shroud area.

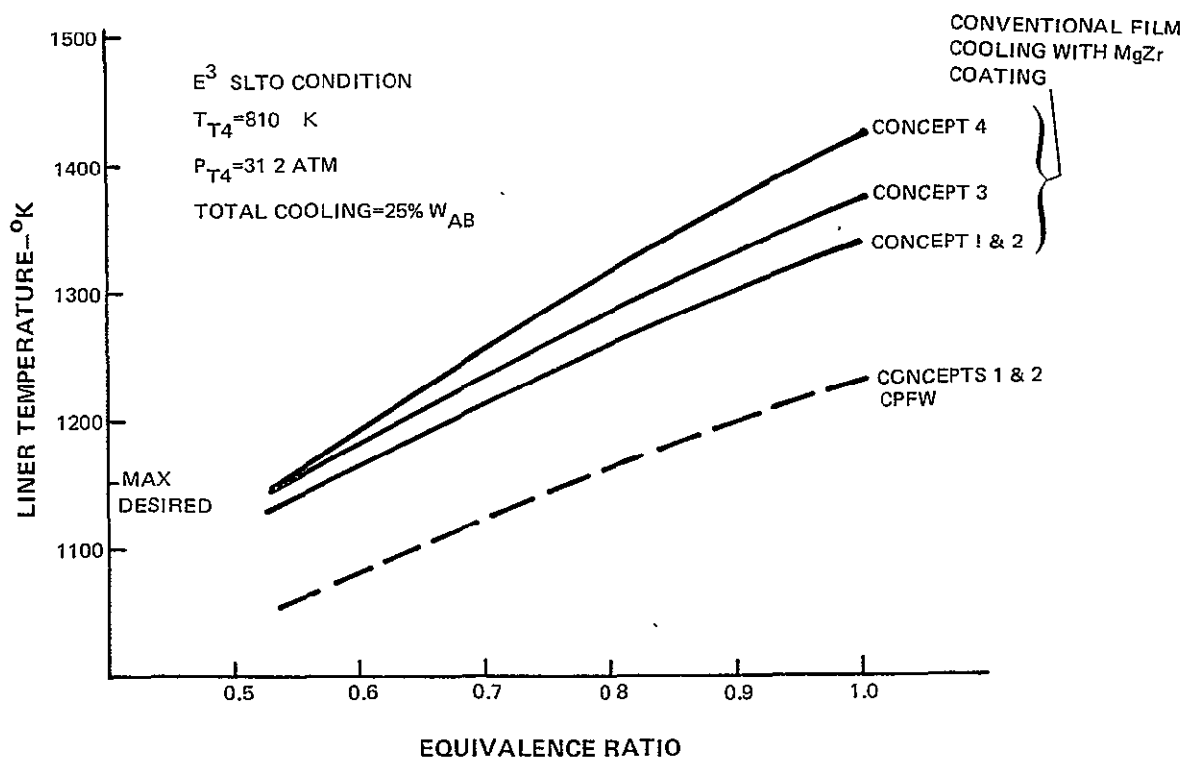

Figure 4-1 Thermal Analysis Results

- o Execution - the push/pull type scheme with a large area of contact is considered worse than a translating ring.

2. Fuel System

Based on experimental engine experience, aerating fuel nozzles are considered to be less troublesome than pressure atomizing fuel nozzles. In addition, concepts utilizing two fuel stages are complex and more susceptible to coke formation.

3. Burner Complexity

Attaching ducts to the burner liner or other features that impact the engine hot section envelope seriously increases complexity.

The relative ranking of the four concepts for each of the evaluation features considered was as follows:

| <u>Feature</u> | Relative Feature Value | <u>Ranking</u> | | | |
|-------------------------|------------------------|----------------|---------|----|---------|
| | | Best | + | + | Worst |
| Linkages | 3 | #3 | - | #4 | #(1, 2) |
| Fuel System | 2 | #4 | #1 | #2 | #3 |
| Burner Liner Complexity | 1 | - | #(1, 2) | #3 | #4 |

Each concept was scored 4 for best in a particular category, 2 or 3 for mid-range and 1 for worst. These relative values were multiplied by the relative feature value, and added to obtain a total ranking value for each concept. The results of this comparative ranking for reliability is shown below. Unfortunately, the two concepts ranked lowest in reliability have the highest potential of meeting the emission and performance goals.

| | <u>Concept No.</u> | <u>Point Total</u> |
|-------|--------------------|--------------------|
| Best | 3 | (16) |
| | 4 | (15) |
| | 1 | (12) |
| Worst | 2 | (10) |

4.2 COST AND TIME TO DEVELOP

Until fabrication drawings are available and construction, testing and final refinements to the combustor hardware have been accomplished, no meaningful estimates can be made of the time and cost to develop one of the LPP fuel combustor conceptual designs into an operational engine combustor. The overall SCERP schedule indicates the information necessary for an accurate time/cost estimate to be several years away during the Phase IV (Engine Demonstration) Program.

The major combustor system components required which contribute towards complexity and subsequently cost and time to develop are itemized below.

| <u>Concept No.</u> | <u>Variable Geometry</u> | <u>Fuel System</u> | <u>Additional Complexity</u> |
|--------------------|--------------------------------|--------------------|------------------------------|
| 1 | Front and dilution air staging | 1-stage | |
| 2 | Front and dilution air staging | 2-stage | |

| | | | |
|---|--|---------|--|
| 3 | Aerodynamic control by diffuser bleed | 2-stage | May require fuel nozzle purge system. |
| 4 | Front and dilution air staging | 1-stage | Requires expansion of burner case and recontouring of the diffuser. |

4.3 WEIGHT RANKING

Since the design work carried out for each concept is not sufficiently detailed to permit reliable absolute weight estimates, only a relative weight ranking of the concepts was made; this is shown below.

| Concept No. | Order (Lightest = 1) |
|-------------|----------------------|
| 1 | 2 |
| 2 | 3 |
| 3 | 1 |
| 4 | 4 |

Concept 4 is considered to be the heaviest because of the expanded diffuser case to incorporate the butterfly valves and three annulus ducts in the OD shroud area. Concept 3 is projected to be the lightest of the designs because it utilizes aerodynamic air modulation rather than mechanical variable geometry hardware which requires crank arms, linkages and unison rings.

Concept 2 is estimated to be slightly heavier than concept 1 because of a bulkier fuel injector system necessary for good structural integrity of a dual fuel stage.

4.4 FAILURE ANALYSIS

A structural failure analysis of the four LPP conceptual combustor designs was conducted to identify potential failure modes and estimate the probability and effects of each mode. The results of this study are presented in Table 4-I.

Each of the four concepts would seriously impact existing engine systems in the areas of installation, maintainability and serviceability. The early stage of LPP fuel combustor system development makes it difficult to define all the problem areas, but it is apparent that a major redesign of any existing engine would be required should one of these concepts be incorporated.

TABLE 4-1

LPP COMBUSTOR
FAILURE ANALYSIS OF PRELIMINARY DESIGNS

| Concept | Possible Failure Modes (Preliminary Design) | Likelihood of Failure as Shown | Severity of Failure if Occurs | Ease of Remedy for Final Design |
|---|---|--------------------------------|--|--|
| 1) Variable inlet mounted on bulkhead and aft bypass | 1. Fuel nozzle vibration. | Minimal | Very severe - fuel leakage, burnout, streaks, etc. | Present design adequate. |
| | 2. Translating tube vibration. | Minimal | Severe - burnout, etc. | Present design adequate. |
| | 3. Bind up or failure of interior linkage or bind up of translating tube. | Moderate | Minimal - variable geometry would be nulled. Severe - Failure could cause high flame temperature. | Hard to design reliable system in hostile environment of burner vibration and thermal gradients. |
| 2) Variable inlet mounted on fuel nozzle and aft bypass valves. | 1. Fuel nozzle vibration. | Minimal | Very severe - fuel leakage. | Present design adequate. |
| | 2. Bind up of translating sleeve or linkage system. | Moderate | Severe - could load up fuel nozzle and fuel leakage. | Very difficult - hostile environment sonic vibrations and severe thermal gradient. |
| | 3. Failure of linkage system. | Minimal | Minimal - variable operation would be nulled. | Beef-up possible. |
| 3) Inlet velocity profile control bleed. | 1. Duct buckling | Likely | Moderate - Flow areas would be affected. Possibility of liner distortion via tubes. | Addition of stiffening rings is feasible and is recommended. |
| | 2. V gutter vibration. | Moderate | Moderate to severe - burnout, aspiration, etc. | Feasible to beef-up. |
| | 3. Seals (front tongue in groove seal and rear end seal). | Likely | Moderate to severe - burnout, etc. | Feasible to redesign. |
| | 4. Strut plate connection fatigue. | Likely | Moderate - bulkhead alignment would be affected if enough plates fail out of the 24 total or if bulkhead distorts thermally. | Feasible to improve connections. Front end thermals more difficult to alleviate. |
| | 5. Front end thermal distortion. | Likely | | |
| 4) Dilution air valve control. | 1. Finger seal deterioration. | Likely | Minimal - zone isolation would be affected but not safety. | Very difficult - seals must be flexible for thermal gradients and assembly but be strong to resist pressure loads. |
| | 2. Duct bulkhead bending - blowoff loads. | Likely | Moderate - bind up of butterfly valves and distortion of outer liner. | Feasible - beef-up needed. |
| | 3. Duct buckling. | Likely | Moderate - zone isolation promised. | Easy - Rings to be added. |

5.0 COMPARISON OF CONCEPTS

5.1 CONCEPT RANKING

5.1.1 Rating Procedure

The four conceptual designs were rated according to their probability of achieving the program goals or matching the operational characteristics of the reference Energy Efficient Engine. The designs developed under Task I were evaluated and compared under the main categories of Emissions, Safety, Performance, Durability and Operation. These categories were sub-divided as follows:

1. Emissions

Gaseous emissions of carbon monoxide, unburned hydrocarbons and oxides of nitrogen over the Environmental Protection Agency specified landing and takeoff cycle, EPAP; emissions of oxides of nitrogen during high altitude cruise; particulate emissions (smoke) at sea level take-off conditions.

2. Safety

Included in this area was the susceptibility of the design to autoignition and flashback, relight capability over the flight envelope and stability during transient operation.

3. Performance

The performance criteria consisted of pressure loss, combustion efficiency, pattern factor, exit radial temperature profile, sensitivity to bleed, weight and cycle performance.

4. Durability

Included in durability were liner temperature, liner failure and susceptibility to fuel nozzle coking.

5. Operation

The operation category consisted of ground start and control requirements.

To determine the rating for each concept, a probability type analysis was first performed with each category. Using the system shown in the tabulation below, individual items were assigned a score between 0 and 1.1 based on the probability of meeting the program goals. The scores were then multiplied together to obtain the overall probability in each main category. A weighting factor appropriate to each category was then applied and the total score determined by summing the individual weighted scores.

SCORING CRITERIA

- 1.1 - Exceeds requirements
- 1.0 - Likely to meet requirements or comparable to reference engine.
- 0.7 - Will require some work to meet requirements.
- 0.3 - Will require substantially more work to meet requirements.
- 0.1 - Very little chance of meeting requirements
- 0 - Will not meet requirements

In establishing the weighting factors, top priority was given to emissions, because it was the prime objective of the LPP program, and safety, because of its obvious importance. Both categories were assigned a weighting factor of 40. Performance and durability were weighted equally and slightly lower at 30 while the operation category was considered to be somewhat forgiving and was assigned the lowest value of 10. Using this method a concept that meets all the goals and requirements will receive a score of 150.

5.1.2 Results

The overall ratings for the four concepts which are summarized in Table 5-I represent the average of several individual ratings obtained from key program personnel. As indicated when all categories are considered, concepts 1 and 2 are clearly superior to concepts 3 and 4 with concept 2 a slight favorite over concept 1. Concepts 1 and 2 scored very well in the emission category while concepts 3 and 4 were considered to have very little potential for satisfying the program NO_x emission goals at cruise: concept 3 because of lack of sufficient bleed capability and concept 4 because of poor fuel air mixing.

Concepts 1 and 2 were both judged fairly close in all categories except in the safety area, where concept 2 was judged superior due to an expected improvement in transient capability achieved with a dual staged fuel nozzle.

Concepts 3 and 4 were also considered inferior relative to 1 and 2 in the performance area, concept 3 due to probable variations in pressure loss and poor combustion efficiencies at approach and concept 4 indicating potentially troublesome pattern factor and exit radial temperature profile.

Although some items in the system used to rate the four concepts could only be assessed qualitatively, it is interesting to note that the results of three individual reviews scored concept 2 the highest.

TABLE 5-I
CONCEPT RATING SHEET

| <u>Category</u> | <u>Concept</u> | | | |
|-------------------|----------------|----------|----------|----------|
| | <u>1</u> | <u>2</u> | <u>3</u> | <u>4</u> |
| Emissions (40) | 36 | 37 | 2 | 4 |
| Safety (40) | 10 | 23 | 20 | 26 |
| Performance (30) | 14 | 14 | 6 | 4 |
| Durability (30) | 19 | 15 | 13 | 15 |
| Operation (10) | 5 | 5 | 7 | 7 |
| <hr/> | | | | |
| Total Score (150) | 84 | 94 | 48 | 56 |

() Weighting Factor

The rating system used to evaluate the four LPP concepts should be considered as an initial step in the selection process. Further along in the development of LPP combustion other items such as cost, time to develop, maintainability and serviceability will have to be given serious consideration.

6.0 CONCLUDING REMARKS

Four LPP combustor concepts utilizing variable geometry and/or other flow control techniques were identified, designed and analytically evaluated for the reference Energy Efficient Engine (E³). One of the concepts (Concept 2) was designed and sized for the JT9D engine cycle and envelope.

Based on the analytical projections made during this conceptual design study, two of the concepts (Concepts 1 and 2) offer the potential of achieving the emission goals while satisfying nearly all of the performance requirements. However, the projected operational characteristics and reliability of any of these concepts to perform satisfactorily over an entire high pressure ratio aircraft engine envelope require extensive experimental substantiation before engine adaptation can be considered.

Other fundamental SCERP Phase I activities and this design study program revealed areas of concern as well as the need for technology improvement. The LPP is based on supplying the combustion zone with well mixed and well vaporized fuel-air mixture. Both these goals may prove to be difficult to attain in practice, within reasonable combustor lengths and without incurring autoignition and/or flashback. In the design of the premixing passages for the LPP systems, precautions were taken to avoid potential flow problems, such as wakes behind variable geometry devices and fuel injectors, which could increase residence time of the fuel-air mixture in the premixing passage. Incomplete mixing/vaporization, hence higher NO_x emissions, were weighed against providing adequate margin to avoid autoignition and flashback.

It is evident that future development must concentrate on achieving uniform fuel-air mixture preparation if the full potential of this concept is to be realized. At the present time the most practical means of achieving rapid fuel vaporization would appear to be ultrafine atomization. Analysis and experimentation should be pursued to determine the time or distance needed to fully vaporize the fuel as a function of airflow properties and fuel drop size. New approaches to fuel atomization aimed at the production of very small droplets should be explored. Allied to this is the problem of measurement of small drop sizes ($\leq 20 \mu$). Every encouragement should be given to new ideas and the development of new techniques for achieving improved means of fuel atomization.

The effect of utilizing larger quantities of front end combustion air requires advanced, efficient cooling techniques to achieve the desired liner durability in the more severe operating environment of future aircraft engines. An additional design consideration is the cooling requirements of the flameholders. On the positive side, lean premixed burning should achieve lower primary zone gas temperatures and flame radiation which in turn should alleviate the cooling requirements.

The anticipated design problems with variable geometry features are their control, operational characteristics and durability. The air staging mechanisms will require control systems and sensors somewhat more complex than those used in current engines.

Although variable geometry introduces complexity with respect to combustor design for emissions reduction, it represents a new degree of freedom for advanced engine designs. Future engine requirements of higher thrust-weight ratios, higher temperature rise, smaller combustor volume and extended flight envelopes will make it difficult to satisfy both emission and performance requirements. Air staging offers the unique potential of significant improvement in both areas.

7.0 REFERENCES

1. Grobecker, A.J., S.G. Coroniti and R.H. Cannon, "The Effects of Stratospheric Pollution by Aircraft, Report of Findings," Department of Transportation Rept. DOT-TST-75-50, Dec. 1974.
2. Andersen, D. N., "Effects of Equivalence Ratio and Dwell Time on Exhaust Emissions from an Experimental Premixing Burner," NASA TM X-71592, 1975.
3. Andersen, D. N., "Effect of Premixing on Nitric Oxide Formation," NASA TM X-68220, June 1973.
4. Roffe, G. and A. Ferri, "Prevaporization and Premixing to Obtain Low Oxides of Nitrogen in Gas Turbine Combustors," NASA CR-2495.
5. Rudey, R. A. and G. M. Reck, "Advanced Combustion Techniques for Controlling NO_x Emissions of High Altitude Cruise Aircraft," NASA TM X-73473, 1976.
6. Spadaccini, L. J., "Autoignition Characteristics of Hydrocarbon Fuels at Elevated Temperatures and Pressures," ASME Paper 76-GT-3, March 1976.
7. Sturgess, G. I., "Advanced Low Emissions Catalytic Combustor Program - Phase I," NASA CR-159656.
8. Appleton, J. P., and J. B. Heywood, "The Effects of Imperfect Fuel-Air Mixing in a Burner on NO Formation from Nitrogen in the Air and the Fuel," 14th Symposium (International) on Combustion, University Park, Pa., August 20-25, 1972, pp. 777-786.
9. Marek, C. J., L. C. Papathakos, and P. W. Verbulez, "Preliminary Studies of Autoignition and Flashback in a Premixing-Prevaporizing Flame Tube Using Jet-A Fuel at Lean Equivalence Ratios," NASA TM X-3526, May 1977.
10. Lean Premixed/Prevaporized Combustion; A Workshop held at Lewis Research Center, Jan. 1977, NASA CP-2016.
11. McVey, J. B. and Jan B. Kennedy "Lean Stability Augmentation Study", NASA CR-159536, May 1979.
12. Roffe, G. and K. S. Venkataramani, "Experimental Study of the Effects of Flameholder Geometry on Emissions and Performance of Lean Premixed Combustors," NASA CR-135424, June 1978.

7.0 REFERENCES (Cont'd.)

13. Goldberg, P., I. Segalman and B. Wagner, "Potential and Problems of Premixed Combustors for Application to Modern Aircraft Gas Turbine Engines, AIAA Paper No. 76-727, AIAA/SAE 12th Propulsion Conference, July 1976.
14. Roberts, R., A. Fiorentino, and W. Greene, "Experimental Clean Combustor Program Phase III Final Report", NASA CR-135253, October 1977.
15. Ozawa, R. I.: Survey of Basic Data on Flame Stabilization and Propagation for High Speed Combustion System; Marquardt Corporation, Technical Report AFAPL-70-81, January 1971.
16. Semerjian, H. G., and A. Vranos: "NO_x Formation in Premixed Turbulent Flames", Sixteenth symposium (International) on Combustion, Cambridge, Ma, August 1976.
17. Cooper, L. P. "The Effect of Degree of Fuel Vaporization Upon Emissions for a Premixed - Prevaporized Combustion System", AIAA Paper No. 79-1320 AIAA/SAE/ASME 15th Joint Propulsion Conference, June 1979 (NASA TM 79154).
18. Adkins, R.C. and A.S. Elsaftawy, "A Double Acting Variable Geometry Combustor," ASME 79-GT-197, March 1979.
19. Semerjian, H.G., I.C. Ball and A. Vranos, "Pollutant Emission from Partially Mixed Turbulent Flames," AIAA Paper No. 77-94, July 1977.

DISTRIBUTION LIST

| I. NASA | Copies |
|--|--------|
| 1. NASA Lewis Research Center 21000 Brookpark Road Cleveland, OH 44135. | |
| Attn: Report Control Office MS 5/5 | 1 |
| Technology Utilization MS 3/19 | 1 |
| Library MS 60/3 | 2 |
| D. Gauntner MS 301/2 | 1 |
| D. Sokolowski MS 301/2 | 1 |
| J. E. Dilley MS 500/305 | 1 |
| W. L. Stewart MS 3/5 | 1 |
| R. A. Rudey MS 60/4 | 1 |
| D. A. Petrash MS 60/6 | 1 |
| L. A. Diehl MS 60/6 | 1 |
| F. A. Lezberg MS 60/4 | 1 |
| R. E. Jones MS 60/6 | 1 |
| G. M. Reck MS 54/6 | 1 |
| R. W. Niedzwiecki MS 54/6 | 1 |
| S. Gordan MS 54/6 | 1 |
| J. Grobman MS 54/6 | 1 |
| USAF Office MS 501/3 | 1 |
| Propulsion Lab., USARIL (AVRADCOM) MS 77/5 | 2 |
| Author or Project Manager | 10 |
| | |
| 2. NASA Headquarters | 1 |
| Attn: RTP-6/Manager, Propulsion Office 600 Independence Avenue, S.W. Washington, DC 20546 | |
| | |
| 3. NASA Scientific & Technical Information Facility | 25 |
| Attn: Accessioning Department P.O. Box 8757 Baltimore/Washington International Airport MD 21240 | |

DISTRIBUTION LIST (CONT'D)

| | Copies |
|--|--------|
| II. OTHER GOVERNMENT AGENCIES | |
| 1. Air Force Office of Scientific Research Attn: B. T. Wolfson Bolling AFB Washington, DC 20332 | 1 |
| 2. Arnold Engineering & Development Center Attn: E. L. Hively Code D1/R Arnold Air Force Station, TN 37389 | 1 |
| 3. ARO Incorporated Attn: Library Arnold Air Force Station, TN 37389 | 1 |
| 4. Bureau of Mines Bartlesville Energy Research Center Attn: Richard Hurn P.O. Box 1398 Bartlesville, OK 74003 | 1 |
| 5. Chief Army Research Office Attn: Mr. J. Murray P.O. Box 12211 Research Triangle Park, NC 27709 | 1 |
| 6. Commander U.S. Army Aviation R&D Command Attn: DRDAV-EQP (Mr. Larry Bell) P.O. Box 209 St. Louis, MO 63166 | 1 |
| 7. Commander U.S. Army Fuels & Lubricants Research Lab Southwestern Research Institute P.O. Drawer 28510 San Antonio, TX 78284 | 1 |
| 8. Defense Documentation Center Cameron Station 5010 Duke Street Alexandria, VA 22314 | 1 |
| 9. Director, Applied Tech. Laboratory Attn: DAVDL-EU-TAP (Mr. Kent Smith) U.S. Army Research & Tech. Lab. (AVRADCOM) Ft. Eustis, VA 23604 | 1 |

DISTRIBUTION LIST (CONT'D)

| | Copies |
|---|--------|
| 10. Environmental Protection Agency Attn: Mr. Richard Munt 2565 Plymouth Road Ann Arbor, MI 48105 | 1 |
| Environmental Protection Agency Attn: Library 2565 Plymouth Road Ann Arbor, MI 48105 | 1 |
| 11. Environmental Protection Agency Attn: Library Mail Drop 65 Research Triangle Park, NC 27111 | 1 |
| Environmental Protection Agency Attn: W. S. Lanier Mail Drop 65 Research Triangle Park, NC 27111 | 1 |
| 12. Environmental Protection Agency Attn: George Kittredge 401 Main Street S.W. Washington, DC 20460 | 1 |
| 13. FAA Headquarters Attn: K. Forney AFS-140 800 Independence Avenue SW Washington, DC 20591 | 1 |
| FAA Headquarters Attn: N. Krull 800 Independence Avenue SW Washington, DC 20591 | 1 |
| FAA Headquarters Attn: Library 2100 Second Street, SW Washington, DC 20591 | 1 |
| 14. Jet Propulsion Laboratory Attn: M. Clayton MS 125-224 4800 Oak Grove Drive Pasadena, CA 91103 | 1 |

DISTRIBUTION LIST (CONT'D)

| | Copies |
|---|--------|
| 15. Naval Air Propulsion Center Attn: Mr. Anthony Klarman PE-71 P.O. Box 7176 Trenton, NJ 03628 | 1 |
| Naval Air Propulsion Test Center Attn: Mr. Bill Wagner TE-43 P.O. Box 7176 Trenton, NJ 08628 | 1 |
| 16. Naval Ordnance Systems Command Attn: Mr. John W. Murrin Department of Navy Arlington, VA 20360 | 1 |
| 17. Wright-Patterson Air Force Base Attn: E. E. Bailey AFAPL/DO Wright-Patterson AFB, OH 45433 | 1 |
| Wright-Patterson Air Force Base Attn: Thomas Jackson AFAPL/SFF Wright-Patterson, AFB, OH 45433 | 1 |
| Wright-Patterson Air Force Base Attn: Robert Henderson AFAPL/TBC Wright-Patterson, AFB, OH 45433 | 1 |
| 18. FAA/NAFE Attn: W. Westfield, ANA-410 Atlantic City, NJ 08405 | 1 |

DISTRIBUTION LIST (CONT'D)

| | Copies |
|--|--------|
| III. UNIVERSITIES | |
| 1. Cornell University Attn: Prof. Sidney Liebovich Sibley School of Mechanical & Applied Engineering Upson & Gruman Halls Ithaca, NY 14850 | 1 |
| Cornell University Attn: Prof. F. Gouldin Sibley School of Mechanical & Applied Engineering Upson & Gruman Halls Ithaca, NY 14850 | 1 |
| 2. Massachusetts Institute of Technology Attn: Prof. J. Heywood Department of Mechanical Engineering Cambridge, MA 02139 | 1 |
| 3. Northwestern University Attn: Prof. C. K. Law Department of Mechanical Engineering & Astronautical sciences Evanston, IL 60201 | 1 |
| 4. Pennsylvania State University Prof. G. M. Faeth Dept. of Mechanical Engineering 208 Mech. Eng. Bldg. University Park, PA 16802 | 1 |
| 5. Purdue University Attn: Prof. A. M. Mellor School of Mechanical Engineering West Lafayette, IN 47907 | 1 |
| Purdue University Attn: Prof. A. H. Lefebvre School of Mechanical Engineering West Lafayette, IN 47907 | 1 |
| 6. Department of Mechanical Engineering Attn: Prof. J. Odgers Laval University Quebec, CANADA Gik 7P4 | 1 |

DISTRIBUTION LIST (CONT'D)

| | Copies |
|--|--------|
| 7. University of California Attn: Prof. R. F. Sawyer Department of Mechanical Engineering Berkeley, CA 94720 | 1 |
| University of California Attn: Prof. J. Daily Department of Mechanical Engineering Berkeley, CA 94720 | 1 |
| 8. University of California Attn: Prof. G. Scott Samuelson Mechanical and Environmental Eng. Irvine, CA 92717 | 1 |
| 9. University of Illinois at Urbana-Champaign Attn: Prof. R. A. Stehlow Dept. of Aeronautical & Astronautical Engineering 101 Transportation Building Urbana, IL 61801 | 1 |
| 10. University of Michigan Attn: Prof. A. Nichols Department of Aerospace Engineering Gas Dynamics Lab. North Campus Ann Arbor, MI 48105 | 1 |
| University of Michigan Attn: Prof. C. W. Kauffman Department of Aerospace Engineering Gas Dynamics Lab. North Campus Ann Arbor, MI 48105 | 1 |
| 11. University of Southern California Associate Dean of Engineering Attn: Prof. Melvin Gerstein School of Engineering Los Angeles, CA 90007 | 1 |
| 12. University of Michigan Attn: Prof. David T. Pratt Dept. Of Mechanical Engineering Ann Arbor, MI 48105 | 1 |
| 13. University of Virginia Attn: Prof. Sam S. Fisher Dept. of Mech. and Aero. Eng. Charlottesville, VA 22901 | 1 |

DISTRIBUTIONS LIST (CON'T)

| IV. INDUSTRY | Copies |
|--|--------|
| 1. Avco/Lycoming Corp. Attn: G. Opdyke 550 South Main Street Stratford, CT 06497 | 1 |
| Avco/Lycoming Corp. Attn: N. Marchionna 505 South Main Street Stratford, CT 06497 | 1 |
| Avco/Lycoming Corp. Attn: Library 505 South Main Street Stratford, CT 06497 | 1 |
| 2. Battelle Columbus Laboratories Attn: Mr. David W. Locklin 505 King Avenue Columbus, OH 43201 | 1 |
| Battelle Columbus Laboratories Attn: Library 505 King Avenue Columbus, OH 43201 | 1 |
| 3. Calspan Corporations Attn: Library 4455 Genesee Street Buffalo, NY 14221 | 1 |
| 4. Curtiss-Wright Corporation Attn: S. Moskowitz One Passaic Street Wooldridge, NY 07075 | 1 |
| Curtiss-Wright Corporation Attn: Library One Passaic Street Wooldridge, NY 07075 | 1 |
| 5. Detroit Diesel Allison Div. Attn: J. Tomlinson Department 8894, Plant 8 P.O. Box 894 Indianapolis, IN 46202 | 1 |
| Detroit Diesel Allison Div. Attn: Library Department 8894, Plant 8 P.O. Box 894 Indianapolis, IN 46202 | 1 |

DISTRIBUTION LIST (CONT'D)

Copies

6. Garrett/AiResearch Company 1
Attn: J. M. Haasis
402 South 36th Street
Phoenix, AZ 85034
- Garrett/AiResearch Company 1
Attn: Library
402 South 36th Street
Phoenix, AZ 85034
7. General Applied Science Laboratories 1
Attn: G. Roffe
Merrick and Stewart Avenues
Westbury, NY 11590
- General Applied Science Laboratories 1
Attn: Library
Merrick and Stewart Avenues
Westbury, NY 11590
8. General Electric Company 1
Attn: C. C. Gleason H-52
Aircraft Engine Group
Evendale, OH 45215
- General Electric Company 1
Attn: D. Bahr H-52
Aircraft Engine Group 1
Evendale, OH 45215
- General Electric Company 1
Attn: E. Ekstedt H-52
Aircraft Engine Group
Evendale, OH 45215
- General Electric Company 1
Attn: Tech. Info. Ctr. N-32
Aircraft Engine Group
Evendale, OH 45215
9. General Electric Company 1
Attn: Library
Gas Turbine Engineering Department
One River Road No. 53-324
Schenectady, NY 12345
- General Electric Company 1
Attn: Dr. Richard Roberts
Energy Systems & Technology Division
Bld. #2 Room 543
One River Road
Schenectady, NY 12345

DISTRIBUTION LIST (CONT'D)

| | Copies |
|---|--------|
| 10. International Harvester Company Attn: W. A. Compton Solar Division P.O. Box 80966 San Diego, CA 92138 | 1 |
| International Harvester Company Attn: Library Solar Division P.O. Box 80966 San Diego, CA 92138 | 1 |
| 11. Northern Research & Engineering Corp. Attn: Library 219 Vassar Street Cambridge, MA 02139 | 1 |
| 12. Parker Hannifin corp. Attn: H. C. Simmons 17325 Euclid Avenue Cleveland, OH 44112 | 1 |
| Parker Hannifin corp. Attn: Library 17325 Euclid Avenue Cleveland, OH 44112 | 1 |
| 13. Teledyne CAE Attn: C. Rogo 1330 Laskey Road Toledo, OH 43697 | 1 |
| Teledyne CAE Attn: Library 1330 Laskey Road Toledo, OH 43697 | 1 |
| 14. United Technologies Corporation Attn: H. Craig Pratt & Whitney Aircraft Group Commercial Products Division 400 Main Street East Hartford, CT 06108 | 1 |
| United Technologies Corporation Attn: P. Goldberg Pratt & Whitney Aircraft Group Commercial Products Division 400 Main Street East Hartford, CT 06108 | 1 |

DISTRIBUTION LIST (CONT'D)

| | Copies |
|---|--------|
| United Technologies Corporation Attn: J. Zimonis Pratt & Whitney Aircraft Group 400 Main Street East Hartford, CT 06108 | 1 |
| United Technologies Corporation Attn: Library Pratt & Whitney Aircraft Group 400 Main Street East Hartford, Ct 06108 | 1 |
| United Technologies Corporation Attn: G. Swanson Pratt & Whitney Aircraft Group 400 Main Street #15-C East Hartford, Ct 06108 | 1 |
| 15. United Technologies Corporation Attn: J. Shadowen Pratt & Whitney Aircraft Group Government Products Division Box 2691 West Palm Beach, FL 33402 | 1 |
| United Technologies Corporation Attn: J. P. Rusnak Pratt & Whitney Aircraft Group Government Products Division Box 2691 West Palm Beach, FL 33402 | 1 |
| United Technologies Corporation Attn: Library Pratt & Whitney Aircraft Group Government Products Division Box 2691 West Palm Beach, FL 33402 | 1 |
| 16. United Technologies Research Center Attn: R. Pelmas Silver Lane East Hartford, CT 06108 | 1 |
| United Technologies Research Center Attn: H. Couch Silver Lane East Hartford, CT 06108 | 1 |

DISTRIBUTION LIST (CONT'D)

Copies

| | |
|---|---|
| United Technologies Research Center Attn: Library Silver Lane East Hartford, CT 06108 | 1 |
| 18. Westinghouse Electric Corp. Attn: Mr. S. M. Decorso Gas Turbine Systems Division Lester Branch Box 9175 Philadelphia, PA 19113 | 1 |
| Westinghouse Electric Corp. Attn: Library Gas Turbine Systems Division Lester Branch Box 9175 Philadelphia, PA 19113 | 1 |
| 19. Westinghouse Electric Corp. Attn: Mr. Richard M. Chamberlain Research and Development Center Pittsburgh, PA 15235 | 1 |
| Westinghouse Electric Corp. Attn: Library Research and Development Center Pittsburgh, PA 15235 | 1 |
| 20. Williams Research Attn: M. Bak 2280 West Maple Walled Lake, MI 48088 | 1 |
| Williams Research Attn: Library 2280 West Maple Walled Lake, MI 48088 | 1 |