

LIFECYCLE MANAGEMENT OF FACILITIES COMPONENTS USING RADIO FREQUENCY IDENTIFICATION AND BUILDING INFORMATION MODEL

PUBLISHED: June 2009 at <http://www.itcon.org/2009/18>

EDITORS: Kazi A S, Aouad G, Baldwin A

*Ali Motamedi, Research Assistant,
Concordia University, Concordia Institute for Information Systems Engineering, Montreal, Canada,
a_mot@ciise.concordia.ca*

*Amin Hammad, Associate Professor,
Concordia University, Concordia Institute for Information Systems Engineering, Montreal, Canada,
hammad@ciise.concordia.ca*

SUMMARY: *The AECOO industry is highly fragmented; therefore, efficient information sharing and exchange between various players are evidently needed. Furthermore, the information about facility components should be managed throughout the lifecycle and be easily accessible for all players in the AECOO industry. BIM is emerging as a method of creating, sharing, exchanging and managing the information throughout the lifecycle between all the stakeholders. RFID, on the other hand, has emerged as an automatic data collection and information storage technology, and has been used in different applications in AECOO. This research proposes permanently attaching RFID tags to facility components where the memory of the tags is populated with accumulated lifecycle information of the components taken from a standard BIM database. This information is used to enhance different processes throughout the lifecycle. In addition, this research suggests storing other types of BIM information (e.g., floor plans) on RFID tags which is not necessarily related to the components themselves. Having BIM data chunks stored on tags provides a distributed database of BIM and allows data access for different players who do not have real-time access to a central database. In this research, a conceptual RFID-based system structure and data storage/retrieval design are elaborated. The value adding benefits and scope of impact of the proposed approach are discussed. To explore the technical feasibility of the proposed approach, two case studies have been implemented and tested.*

KEYWORDS: *RFID, Lifecycle Management, Building Information Model, Construction Automation, Distributed Information*

REFERENCE: *Motamedi A, Hammad A (2009) Lifecycle management of facilities components using radio frequency identification and building information model, Journal of Information Technology in Construction (ITcon), Vol. 14, Special Issue Next Generation Construction IT: Technology Foresight, Future Studies, Roadmapping, and Scenario Planning, pg. 238-262, <http://www.itcon.org/2009/18>*

COPYRIGHT: © 2009 The authors. This is an open access article distributed under the terms of the Creative Commons Attribution 3.0 unported (<http://creativecommons.org/licenses/by/3.0/>), which  permits unrestricted use, distribution, and reproduction in any medium, provided the original work is properly cited.

1. INTRODUCTION

Radio frequency identification (RFID) is a type of automatic identification technology in which radio frequencies are used to capture and transmit data. It acts as electronic labelling and data-collection system to identify and track items. RFID based systems have been used in different applications in construction and maintenance, such as component tracking and locating, inventory management, equipment monitoring, progress management, facilities and maintenance management, tool tracking, material management and quality control (for example Jaselskis and El-Misalami 2003, Song et al. 2005, Ergen 2007a, Kiziltas et al. 2008). However,

each of the above-mentioned applications is designed for only one specific stage of the facility lifecycle to serve the needs of only one of the stakeholders in a fragmented fashion, i.e., Architects, Engineers, Constructors, Owners and Operators (AECOO). This would increase the cost and the labor for adding and removing different tags at different stages and eliminate the chance of using shared resources among the stakeholders causing duplication of efforts and resources.

This research proposes permanently attaching tags to components in the manufacturing stage as an integrated part of the components. Having the tags permanently attached, where the information on the tags is gradually updated with accumulated lifecycle information, is beneficial for all the stakeholders throughout the stages of the lifecycle, from procurement and supply chain management to maintenance and disposal.

The use of attached RFID tags for lifecycle management has been proposed in the aerospace industry for storing unique ID and important lifecycle information on tags attached to aircraft parts for enhancing inspection and repair processes. The suggested information to be stored includes the details of configuration (e.g., installation date, removal from aircraft date), details of part modifications, inspection, repair and transfer history (Harrison et al. 2006, Harrison 2007). One of the main challenges faced in this project was the assurance of the authenticity and integrity of data as well as using a standard data format for sharing information among different organizations.

Ergen et al. (2007b) proposed using RFID tags attached to engineered-to-order (ETO) components during their lifecycle and explored the technical feasibility of such system by analysing component-related information flow patterns in ETO supply chains. They also noted that integration of the data accessed with the broader information systems used across diverse organizations is an issue that needs to be investigated.

Our framework proposes techniques to manage components' lifecycle data as well as extending the idea of RFID-attached component to other types of engineered components within a constructed facility (i.e., made-to-order and off-the-shelf components). We also propose to include broader data types on the RFID tags that are attached to building components and are spread in a building.

In the proposed approach, the information on the tags represents chunks of the Building Information Model (BIM) as a distributed database. On the other hand, RFID specific data (e.g., the unique ID) should be added to the BIM. This coupling between the BIM and the RFID information would allow reconstructing the database of the BIM (or part of it) based on the pieces of information distributed in all the attached tags. The memory on the tags is divided into different sections, which will be gradually filled with updated information based on the current status of the component (e.g., manufactured, shipped, lifted, installed, in service, waiting for repair). Hence, the status information is the key changing information that identifies what subsystem(s) can use the data space on the tag.

The proposed approach is further explored in two case studies of a high-rise building by deploying RFID tags on selected components for improving supply chain management, locating items, installation and maintenance activities, as well as progress management and visualization.

The objectives of this paper are: (1) to review current research on the applications of RFID technology in the AECOO industry and product lifecycle management and to survey the current status of research on BIM; (2) to investigate the idea of components lifecycle management using RFID tags populated with BIM data; (3) to investigate some detailed data interaction patterns, identifying the scope of impact and prospective value adding benefits and challenges; and (4) to demonstrate the feasibility of the proposed approach through real world case studies.

2. REVIEW OF RELATED RESEARCH

2.1 Radio Frequency Identification

RFID tag is a memory storage device for storing a certain amount of data such as the product identification, price and manufacturing date. This information can be read wirelessly providing the ability to process large volumes of multiple data sets simultaneously. Similar to barcodes, RFID is a technology for identifying, locating, and tracking objects. However, RFID technology introduces several advantages over barcoding in that its operation does not require line-of-sight or clean environments. RFID has been identified as one of the ten greatest contributory technologies of the 21st century. This technology has found a rapidly growing market, with global sales expected to top US\$7B by 2008. An increasing variety of enterprises are employing RFID to improve their efficiency of operations and to gain a competitive advantage (Chao et al. 2007).

2.1.1 RFID technology components

RFID technology is a wireless technology based on the detection of electromagnetic signals (McCarthy et al. 2003). A basic RFID system consists of three components: an antenna, a transceiver (with decoder) and a transponder (RF tag) electronically programmed with information. The emission of radio signals by the reader's antenna activates a tag to read or write data from/to it. The transceiver is responsible for the data acquisition and communication. The antenna can be packaged with the transceiver and decoder in order to become a reader. The reader can be configured either as a handheld or a fixed-mount device. It can be part of other mobile computing and communication devices such as cell phones or Personal Digital Assistants (PDAs). The emission of radio waves from the reader to activate the tags can reach 100 feet or more, depending on its power output and the radio frequency. If an RFID tag is placed in the electromagnetic zone produced by reader's antenna, it detects the activation signal and responds by sending the stored data in form of electromagnetic waves. The reader decodes the data which are encoded in the integrated circuit of the tag and passes them to the host computer system for processing (Domdouzis et al. 2007, aimglobal.com 2008). A typical RFID system is shown in **Error! Reference source not found.**

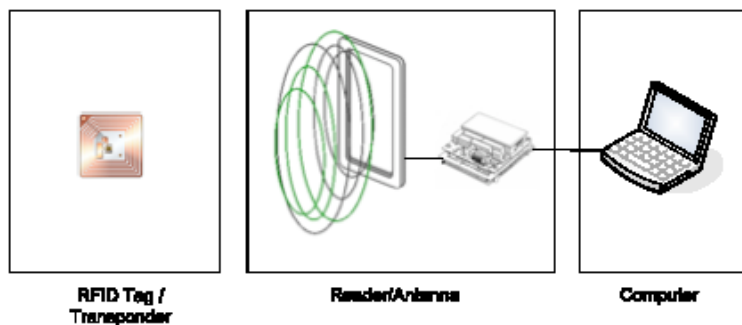

FIG. 1: RFID system

2.1.2 Tag types

Two major types of RFID tags are available: active and passive. Active RFID tags are powered by an internal battery. The memory size of an active tag varies and some tags have more than 1MB of memory. The power supplied by the internal battery of an active tag generally gives it a longer read range. Active tags are usually bigger and more expensive than passive ones and have a limited operational life which may yield a maximum of 10 years, depending on operating temperatures and battery type (aimglobal.com 2008).

Passive RFID tags do not need any external power source and obtain operating power generated from the reader. Passive tags are consequently much lighter than active tags, less expensive, and offer a virtually unlimited operational lifetime. The trade off is that they have shorter read ranges than active tags and require a reader with higher power.

2.1.3 Operating frequencies

RFID systems currently operate in the Low Frequency (LF), High Frequency (HF) and Ultrahigh Frequency (UHF) bands. Each frequency has advantages and disadvantages relative to its capabilities. Generally a lower frequency means a lower read range and slower data read rate, but better capabilities for reading near or on metal or liquid surfaces compared with higher frequencies (scansource.com 2008).

2.2 Building Information Model

The AECOO industry is highly fragmented in nature. Thus, it involves bringing together multi-disciplines and different parties in a project that requires a tremendous amount of coordination. This situation has resulted in significant barriers to communication between the various stakeholders, which in turn has significantly affected the efficiency and performance of the industry (Isikdag et al. 2008). Gallaher et al. (2004) indicated that US\$15.8B is lost annually in the U.S. Capital Facilities Industry due to the lack of interoperability. Consequently, there is an evident need for a standard information transfer model between different software applications used in the AECOO industry. The BIM has been developed in order to tackle the problems related

to interoperability and information integration by providing effective management, sharing and exchange of a building information through its entire lifecycle (Isikdag et al. 2008).

2.2.1 Definition and scope

According to Associated General Contractors Guide (2006), BIM is a data-rich, object-oriented, intelligent and parametric digital representation of facilities. Views and data appropriate to various users' needs can be extracted and analyzed to generate information that can be used to make decisions and improve the process of delivering the facility.

NBIMS (2007a) described the scope of BIM within the following relationships: (1) *BIM as a product* or intelligent digital representation of data about a capital facility, (2) *BIM as a collaborative process* which covers business drivers, automated process capabilities, and open information standards use for information sustainability and fidelity, and (3) *BIM as a facility lifecycle management tool* of well understood information exchanges, workflows, and procedures which stakeholders use throughout the building lifecycle as a repeatable, verifiable, transparent, and sustainable information based environment. BIM acts as an enabler of interoperability and is a facilitator of data sharing and exchange between software applications. Furthermore, BIM is extensible, open and vendor neutral (Isikdag et al. 2008).

2.2.2 BIM data storage, exchange and sharing models

BIM data can be stored as a digital file or in a database, and can be shared and exchanged between several applications. The difference between data sharing and data exchange is related to ownership and centrality of data. In the data exchange model, while the master copy of data is maintained by one software, the snapshots of data are exported to others to use. The ownership is assumed by the software that imports the exchanged data. In the sharing model, there is a centralized control of ownership and there is a master copy of data. The data sharing model facilitates the revision control issue associated with the data exchange model (Isikdag et al. 2007, Vanlande et al. 2008).

Isikdag et al. (2007) explored five different methods for storage and exchange of BIMs: (1) *Data exchange by using physical files* where the files are transferred using physical mediums (e.g., CD/DVD) or computer networks (e.g., Internet), (2) *Data sharing by using application programming interfaces (APIs)* where the BIM physical file can be accessed through proprietary or standard API based on the type of BIM in use. In case the physical file is an Extensible Markup Language (XML) file, then the model can be shared using appropriate XML interfaces (i.e. APIs supporting Document Object Model (DOM)), (3) *Data sharing by using a central database* that allows multiple applications to access the data and use database features such as query processing and business object creation, (4) *Data sharing by using federated project databases* where multiple distributed but synchronized databases can be accessed through single unified view, and (5) *Data sharing by Web services* where a Web service interface provides access either to the central project database where the BIM is stored, or to an API which provides access to a physical BIM file or to the domain specific views of the model.

2.2.3 IFC model

The Industry Foundation Classes (IFC) standard developed by International Alliance of Interoperability (IAI) has matured as a standard BIM in supporting and facilitating interoperability across the various phases of the construction lifecycle (Isikdag et al. 2008). IFC is an object-based, non-proprietary building data model intended to support interoperability across the individual, discipline-specific applications that are used to design, construct, and operate buildings by capturing information about all aspects of a building throughout its lifecycle. It is developed as a means to exchange model-based data between model-based applications in the AECO industry, and is now supported by most of the major CAD vendors as well as by many other applications (Khemlani 2004).

The IFC effort closely parallels another collaborative representation effort known as STEP (STandard for the Exchange of Product model data). Initiated in 1984 by the International Standards Organization (ISO), STEP was focused on defining standards for the representation and exchange of product information in general, and continues to be used in various design disciplines, such as mechanical design, product design, and so on. Several people involved in STEP from the building industry realized that a more domain-specific model was needed for representing building data; they subsequently got involved with IAI and brought to it their experience in defining industry-based standards. Since IFC is an open data exchange format, it is publicly accessible to everyone and can be used by commercial applications to exchange data (Khemlani 2004).

2.2.4 National Building Information Model Standard (NBIMS)

Completion of the IFC model (version 2x3) facilitated the development of exchange standards. In 2005, the Facility Information Council of the National Institute of Building Sciences (NIBS) formed the National Building Information Model Standard (NBIMS) group. According to its charter (NBIMS 2005), the vision of NBIMS is “an improved planning, design, construction, operation, and maintenance process using a standardized machine-readable information model for each facility, new or old, which contains all appropriate information created or gathered about that facility in a format useable by all throughout its lifecycle.” One of the objectives of NBIMS group is to speed the adoption of an open-standard BIM through the definition of information exchange standards based on the IFC model (East and Brodt 2007).

2.2.5 Construction Operations Building Information Exchange (COBIE)

Construction industry contracts require the handover of various documents such as equipment lists, product data sheets, warranties and spare part lists. This information is essential to support the operations, maintenance, and management of facilities by the owner and/or property manager. In 2002, IFC-mBomb project demonstrated an approach for data capturing during design and construction, and data handover to facility operators (Stephens 2005, IFC-mBomb 2004).

Construction Operations Building Information Exchange (COBIE) project was initiated in 2006 under NBIMS support with the objective of identifying the information exchange needs of facility managers and operators of data available upstream in the facility lifecycle (e.g., during design and construction). The COBIE team concluded that the minimum critical set of data needed by Operation and Maintenance (O&M) staff is the location, warranty duration, and parts suppliers for installed equipment (East and Brodt 2007).

COBIE simplifies the work required to capture and record project handover data by recording the data as it is created during design, construction, and commissioning. Designers provide floor, space, and equipment layouts. Contractors provide make, model, and serial numbers of installed equipment. Much of the data provided by contractors comes directly from product manufacturers who can also participate in COBIE (East 2008). FIG. shows COBIE process overview where various data are transferred between main phases of the lifecycle.

While COBIE is designed to work with the BIM, COBIE data may also be created and exchanged using simple spreadsheets. The COBIE team selected spreadsheets so that the benefits of the COBIE approach can be widely used throughout the facility acquisition industry, not just on large, high-visibility projects (East 2008).

The COBIE Pilot implementation standard was published as Appendix B of the NBIMS (NBIMS 2007b). The underlying IFC model description of the COBIE pilot standard was also published for international evaluation (IDM 2007).

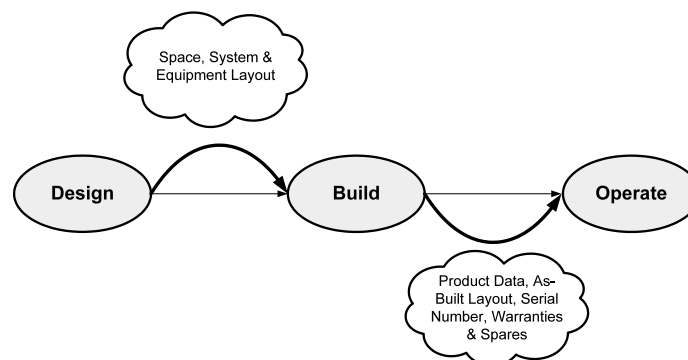

FIG. 2: COBIE process overview (adopted from East, 2008)

2.3 Applications of RFID in the AECOO industry

While RFID technology has significant beneficial applications in manufacturing, retailing, transport and logistics industries, its potential applications in the AECOO industry have only begun to be explored (Song et al. 2006). The main usage of RFID is in supply chain management and the tracking of materials, components, workers and equipment in construction projects (Jaselskis et al. 1995, CII 2000, Jaselski and El-Misalami 2003, Chin et al. 2005, Song et al. 2005a, Ghanem et al. 2006, Goodrum et al. 2006, Yoon et al. 2006). However, some researchers have proposed using RFID for tracking components during inspection and maintenance activities (SAP 2005). The research on applications of RFID in AECOO industry can be roughly categorized as follows:

2.3.1 Material tracking/supply chain

Jaselskis et al. (1995) discussed an RFID system for tracking concrete delivery vehicles. Their proposed system would ensure proper delivery, billing and quality control of concrete. Song et al. (2006) tested RFID tags for tracking the delivery and receipt of pipe spools on the construction site.

Jaselskis and El-Misalami (2003) also performed pilot tests in which passive RFID tags were used in the receiving process of pipe hangers and pipe supports at job site laydown yards (Fig. 3). The pilot tests demonstrated the usefulness of the technology in receiving the unique engineered materials, but the fact that the RFID handheld reader had to be within a few inches of a tag for proper reading was considered as technical difficulty (Song 2006a).

RFID technology is proposed for tracking construction components through a supply chain. Akinci et al. (2002) and Ergen et al. (2003) proposed the use of RFID technology in tracking precast concrete pieces and storing information associated with them through a supply chain.

The combination of RFID technology with the Global Positioning System (GPS) has been investigated in projects in which the materials that are tagged can be automatically identified and tracked on construction sites by field supervisors or material handling equipment that are equipped with an RFID reader and a GPS receiver (Song et al. 2006b). As shown in Fig. 4, RFID was used in conjunction with GPS for tracking and locating components in a precast storage yard (Ergen et al. 2007c).



FIG. 3: Worker receiving pipe support using RFID (Jaselskis et al. 2003)



FIG. 4: Tracking and locating components in a precast storage (Ergen et al. 2007)

2.3.2 Construction management

For identification and tracking of construction components on site, Furlani and Pfeffer (2000) developed a prototype system based on an overall system architecture proposed by Furlani and Stone (1999). In their proposed system, different technologies, (e.g., barcoding, RFID and 3D scanning laser systems) were used for the identification and tracking of tagged structural steel components.

Furlani et al. (2000) attached tags to structural steel members on the construction site to track them and used the identification information on the tags to query a project database for additional information related to the scanned items, such as the 3D CAD model of the steel part.

RFID tags have been used to track assets and to provide security on the construction site by monitoring the site and alerting the site managers when an item has been taken away from the site (Domdouzis et al. 2007, FIATECH 2004). Goodrum et al. (2006) explored the application of active RFID for tool tracking on construction sites. Furthermore, Yabuki and Oyama (2007) studied the application of RFID for the management of light-weight temporary facility members (Fig. 5).

Yagi et al. (2005) proposed the concept of “parts and packet unification” in which unique ID is stored on construction components’ tags to control and enhance the production and assembly processes. Umetani et al. (2006) demonstrated the feasibility of their method using a module assembly experiment.

Several researches discussed the usability of RFID to build a project progress monitoring framework by integrating 4D CAD with RFID technology under a collaborative environment through the supply chain of a project (Hammad and Motamedi 2007, Chin et al. 2005, 2008 , Ghanem and Abdelrazig 2006). Fig. 6 shows the process of attaching RFID tags to steel members in order to facilitate the process of progress monitoring in construction projects.

2.3.3 Quality control



FIG 5: Management of light weight temporary facility members (Yabuki et al. 2007)



FIG 6: Attaching RFID tag on steel members for progress management (Chin et al. 2008)

Peyret and Tasky (2002) used RFID technology to track the delivery vehicles of plant mixed asphalt for quality control purposes. Production data related to a batch of asphalt were automatically collected on an RFID tag mounted on the asphalt hauling truck and transferred to the asphalt paver on site, while the position of a particular batch of asphalt being laid was provided by the GPS receiver mounted on the paver (Song 2006a).

Yabuki and Oyama (2007) used passive UHF tags to track records of actual usage period of light temporary facility members such as pipes, scaffolding plates and frames.

2.3.4 Inspection and maintenance

Schell (2001) reported a pilot test at California oil refinery plant where the rugged RFID tags were attached to pressure relief valves in order to improve the maintenance process. In this project, the annual re-certification information of the valves were simultaneously written to the tags and recorded in the maintenance facility's database. Then, the valves were returned to the refinery with the RFID tags populated with the new certification information. Yabuki et al. (2002) suggested an on-site inspection support system by using a combination of RFID tags and PDAs. They attached RFID tags to specific facility components and stored the latest inspection information and measured data on them. Ergen et al. (2007a) determined the technological feasibility of using UHF active tags during the operation and maintenance phase by repetitively testing the tags attached to fire valves over an extended period of time. RFID technology has been widely implemented at Fraport airport (Legner and Thiesse 2006) where almost 22,000 fire shutters have been equipped with protected RFID tags to store maintenance history. Yabuki et al. (2004) studied the application of RFID in the inspection of a large dam. 68 RFID tags were attached to various members, equipments and measuring devices at Haneji Dam in Okinawa, Japan for supporting inspection activities.

3. PROPOSED APPROACH

The lifecycle of a building can be divided into four main stages which are: design, construction, operation and maintenance and decommissioning/disposal/recycling/reuse. Each stage is generally managed independently and is divided into superimposed layers. Each layer has its own information and also exchanges partial information with other layers. In addition, the constructed facility is composed of various components that must be managed through the above mentioned stages. Thus, the information related to each component should be tracked separately throughout the lifecycle. Furthermore, the information should be in a convenient format and stored at a suitable location to enable all the stakeholders to efficiently access throughout the lifecycle. Effective and immediate access to information minimizes the time and labour needed for retrieving information related to a

component and reduces the occurrence of ineffective decisions that are made in the absence of information (Ergen et al. 2007b).

As mentioned above, the need for providing easy-to-access product and process related information for all stakeholders has resulted in various BIM standards such as NBIMS as discussed in Subsection 2.2. Centrally stored information that is accessible electronically over a computer network is a solution for data access. However, having real-time access to information could be difficult since reliable connections to the central data storage may not be always available. Furthermore, downloading the relevant data for the desired component or process from a central database could be a complicated and time consuming task.

This research proposes adding structured information to tags attached to the components by using RFID technology that provides the data storage capacity on the tags. Having the essential data related to the components readily available on the tags provides easy access capability for whoever needs to access the data regardless of having real-time connection to the central database or having a local copy of the required information.

The ability to store information in digital format on the components can provide “level one product intelligence” for the components (Ergen et al. 2007b). Wong et al. (2002) defined a component with the following characteristics as level one intelligent product: (1) possesses a unique identity, (2) is capable of communicating effectively with its environment, and (3) can retain or store data about itself. Since an RFID tag can be used to store the above information and is capable of communicating wirelessly with the environment, it is considered to be capable of adding such intelligence to the component. Moreover, this distributed memory space of the tags can store information not only related to the component itself but also related to processes or environment data, and can function as a distributed database.

Based on the proposed approach, RFID tags are attached to a selection of building components such as HVAC control units, boilers, etc. It is assumed that the RFID tags can be sensed from relatively long distance and can store several kilobytes of data. The data to be stored on the tags are derived from a BIM database, based on the size of memory and the stage of the component in its lifecycle.

3.1 System interaction design

In our proposed approach, every component is a potential target for tagging. The RFID tags can be attached to components or, based on the uprising Internet of Things (IoT) trends, could be integrated in the components as an integral part (EPoSS 2008). Having standard tags attached to components would result in a massive tag cloud in the building.

While having tags attached to all components would not happen in the immediate future, in order to benefit from the concept of having identity and memory tags on a mass of items, the subset of components to be tagged can be selected based on a cost-benefit analysis. The selection of the components for tagging is based on the scale of the project, types and values of the components, specific processes applied to these components (i.e., acquiring, assembling, constructing, inspecting, maintaining), and the level of automation and management required by the facility owners.

The information stored in this fragmented memory space can be used to facilitate different processes as will be discussed in Subsection 3.5. The system design, including the data structure model and data acquisition method, is general for all components. The target components are tagged during or just after manufacturing and are scanned at several points in time. The scan attempts are both for reading the stored data, or modifying the data based on the system requirements and the stage at which the scan is happening.

The scanned data are transferred in real time to different software applications and processed to manage the activities related to the components. Fig. 7 shows the conceptual design for interaction between different system components. The generic software application communicates with RFID tags by using the reader API and stores and retrieves the lifecycle data to/from a central BIM database. The RFID specific information is added to the BIM database in the design phase as part of the product information. This information includes: the ID, type of the tag, location of the tag on the component and memory/RF specifications. The BIM implementations should be extended to contain this information.

The memory of the tag contains a subset of BIM information. While the BIM database is being populated by information by different software applications throughout the lifecycle, the tag memory space is modified and updated as the component is scanned. The amount of information that should be written on a tag is related to the available memory of the tag and the stage of lifecycle that the component is in. Some of this information is permanent, such as the ID which is the key information for the identification of the component in the database. In contrast, some BIM information chunks are stored on the tags only for a specific lifecycle stage where the information is useful for specific processes, such as installation instructions which are useful only during the installation stage. The types of information that can be stored on the tags will be discussed in detail in Subsection 3.3. Fig. 8 conceptually shows how BIM data chunks are stored on tags attached to the building components. While the information is centrally stored in the BIM database, software applications copy the necessary information from the database to the memory space on the tags.

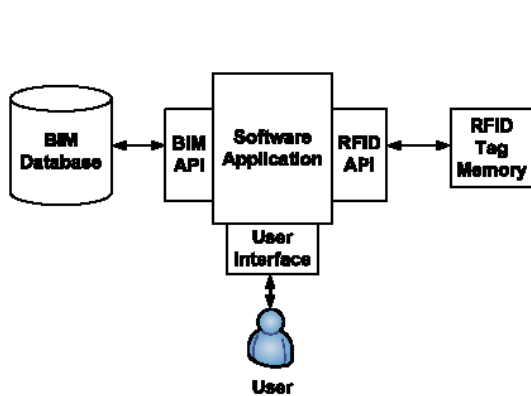

FIG. 7: Conceptual system interaction design

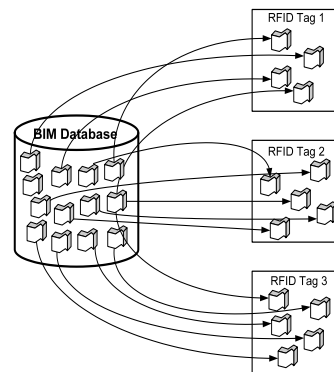

FIG. 8: Conceptual BIM-Tag data relationship

3.2 Data capture methods

The structured data stored on the tags should be read, updated and changed by several RFID-based systems during the lifecycle. These modifications are executed by different types of RFID readers. In order to identify the suitable type of reader for each scan attempts, the detailed process requirements should be captured, such as the readability range, data transfer rate and portability.

In general, building components can be categorized into three groups: (1) fixed components in the structure (e.g., walls, HVAC parts), (2) movable components (e.g., Fire extinguishers, or fixed component before installation) and, (3) temporary components that are used during the construction (e.g., scaffoldings). There are also two types of readers that could be used for data interaction with the tags: stationary readers and mobile readers. Stationary readers can be located at the gates or any designated place within the facility to detect moving components. Mobile readers can be used to interact with both movable and fixed components.

The data stored on the components can be read from different distances. The maximum readability distance depends on various factors, such as power level of reader, antenna type and size, frequency range and environmental factors. In some applications, it is desirable that the data be read from far distance. Hence, the system can detect the component, and related information can be read even if the component is hidden or not visible. If the location data is stored on the tag (for the fixed components) or the tag has a positioning sensor (e.g., GPS), the ability to read the data from a distance provides the required information to locate them. Other applications may require shorter readability. For example, if the tags are used to facilitate inspection activities, having short read/write range would guaranty that the inspector was in the required proximity of the component.

In the proposed approach, RFID tags are fixed to components; therefore, tags should be designed to have the maximum possible range and protection from noise and interference. However, it is always possible to control read/write range on the reader based on the process requirements.

The fact that multiple tags can be simultaneously read with no line of sight provides large time reduction for detection and data capture. However, having too many tags will cause interference and increase the noise level. There are several detailed design challenges for different applications that should be tackled and will be discussed in detail in Section 5.

3.3 Conceptual data structure

As discussed in Subsection 3.1, in our proposed approach, lifecycle information are centrally stored in a BIM database and a subset of this information is stored on the tags. The BIM database contains information related to building components and lifecycle processes in addition to information related to the environment of the component. As discussed above, considering the limited memory of the tags, the subset of data stored on the tags has to be chosen based on the requirements. While data on a tag are changing during the lifecycle of the component and different software applications use and modify the data with different designated access levels, the memory of the tag should be virtually partitioned in a structured fashion based on predefined data types. This structure would also allow further expandability and facilitate the process of data management. In addition, it provides the required segmentation hierarchy needed for implementing different levels of data security and encryption. Furthermore, the ownership of the memory partitions and the read/write access should be designated to appropriate software applications based on the component's lifecycle stage and security/access levels.

We propose to virtually partition the memory space into the following fields as shown in Table 1: (1) ID, (2) specifications, (3) status, (4) process data, (5) history data, and (6) environment data.

Table 1- Conceptual data structure

Field	ID	Specifications	Status	Process Data	History Data	Environment Data
Description	Unique identifier	Component specifications	e.g., installed, shipped, assembled	Data related to current stage of component in the lifecycle	Accumulated, event driven data recorded during the lifecycle	Data related to component's environment

ID

In order to look up the component in the BIM database, there is a need to have a none-changeable, unique identifier (ID) for each component. There are standard coding schemes that can be used for providing structure for the ID. One of the most referred and implemented schemes is EPCglobal (Electronic Product Code) Tag Data Standards (EPCglobal 2008). The EPC typically consists of three ranges of binary digits (bits) (Harisson et al. 2004): (1) an EPC manager (often the manufacturing company ID), (2) an object class (usually the product line or Stock Keeping Unit), and (3) a unique serial number for each instance of a product. Fig. 9 shows an example of EPC ID.

01 . 0000A89 . 00016F . 0024579DC
 Header EPC Manager Object Class Serial Number

FIG. 9: Example of EPC ID

Specifications

This field is dedicated to specifications of the component derived from the design and manufacturing stage of the lifecycle. The information of this portion should remain with the component throughout its lifecycle. Safety related information and hazardous material information are examples of *specifications*.

Status

Status field identifies the current main stage (e.g., in service, installed, manufactured, and assembled) and sub-stage (e.g., in service: waiting for inspection) of lifecycle of the component. The *status* information is used to decide which software application can use and modify the data in the *process data* field.

Process data

This field is relatively large compared to the other fields and is designed to store the information related to the component's current stage of the lifecycle. The data related to current processes to be stored on the tags are different and should be changed during the lifecycle. For example, assembling instructions are used only in the assembly stage. Therefore, the *process data* field contains only information related to the current lifecycle stage taken from BIM database. Moreover, the ownership (ability to read, modify or change) of the *process data*, should be restricted to one or a group of applications (e.g., inspection management software, installation

management software) that are involved in that specific stage. The ownership of the *process data* field is decided based on the *status* field as explained above.

Fig. 10 shows how different software applications modify the *process data* field. Different applications use the same memory space but at different lifecycle stage. Fig. 10 demonstrates a sample component that follows a specific lifecycle pattern where BIM information is copied by different software applications on the memory of its RFID tag.

History data

This field is designated for storing the history data used during the lifecycle for maintenance and repair purposes. The history records are derived from BIM and accumulated during the lifecycle to be used in forthcoming stages.

Environment data

This field is designated for storing environment specific data, such as the location or the functionality and specifications of the space. Hence, *environment data* field contains all the information that is not related to the component itself. The *environment data* is also taken from BIM but it contains the information coded under concepts such as “spaces” in BIM. Examples of *environment data* are: functionality of the space that the component is in, occupants’ data and floor plan.

3.4 BIM-Tag data exchange method

As described in Subsection 3.1 the proposed approach suggests using the attached RFID tags as a media for storing the structured information and providing a distributed data storage of BIM information. According to the fact that the media for storing the data is transparent to the efforts to collect, manage and share data, the data can be stored in a central database, RFID tags, or in printed documents based on a data management standard. However, having information on the RFID tags would provide anytime access to data, information redundancy, and independency from having local database or connection to a central database and more accurate and timely update of data.

Several research projects are undergoing on the subjects of lifecycle information management and identification of information exchange paths and handover methods between AECOO participants. Furthermore, as described in Subsection 2.2.5, there are projects to define data exchange methods and to identify the subset of crucial data that should be available during the lifecycle.

In order to support the implementation of our methodology there is a need for further research and standardisation efforts in BIM in the following areas: (1) IFC extensions considering the whole lifecycle data management, (2) information exchange paths between AECOO and, (3) data handover methods including the definition of crucial subset of data in every stage. It is also necessary to add RFID-related information such as the ID, specification of the tag (e.g., RF standard, range, physical properties, temperature range), and location of the attached tag on the components to existing properties in BIM database. New developments in these areas can be easily incorporated in our proposed approach.

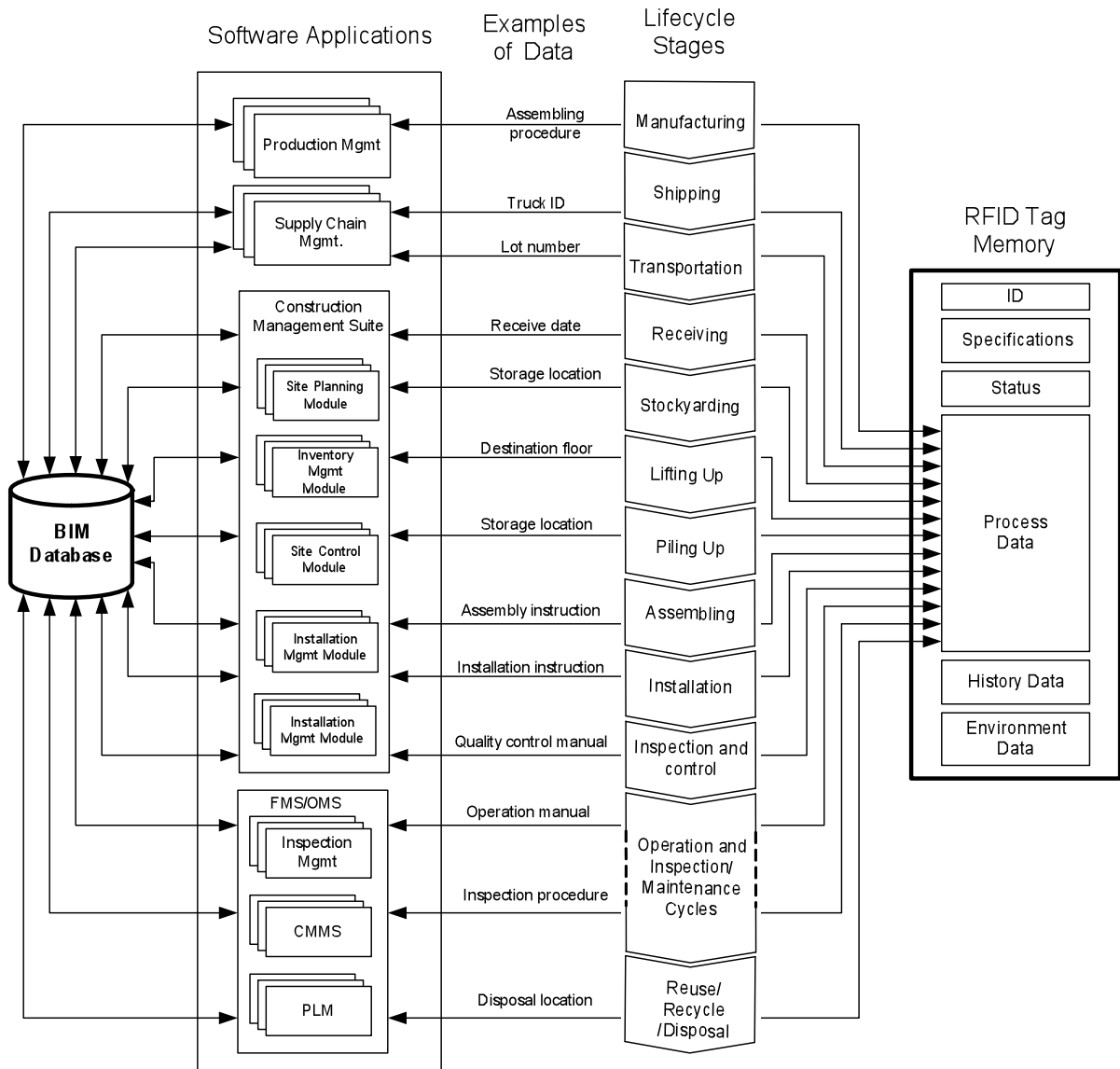

FIG. 10: Process data update

3.5 Tag-System data interaction model for status tracking

As discussed in Subsection 3.3, the *status* data is used as an identifier for lifecycle stages of components. Hence, by using the *status* data, the subsystems that are permitted to read/modify the *process data* field are identified. Status data is updated by RFID scans where an RFID reader writes the new status on the tag; the status will be changed in the BIM database accordingly.

In order to demonstrate the relationship between activities timeline during the lifecycle and the related RFID-based processes that should be performed to update the status of each component, a typical work pattern for building components is used. In this pattern, the components follow the steps in the lifecycle of the constructed facility that are shown in Fig. 11. Different players, activities and component statuses during the lifecycle are shown in the figure. The activities are described following the stage number in Fig. 11.

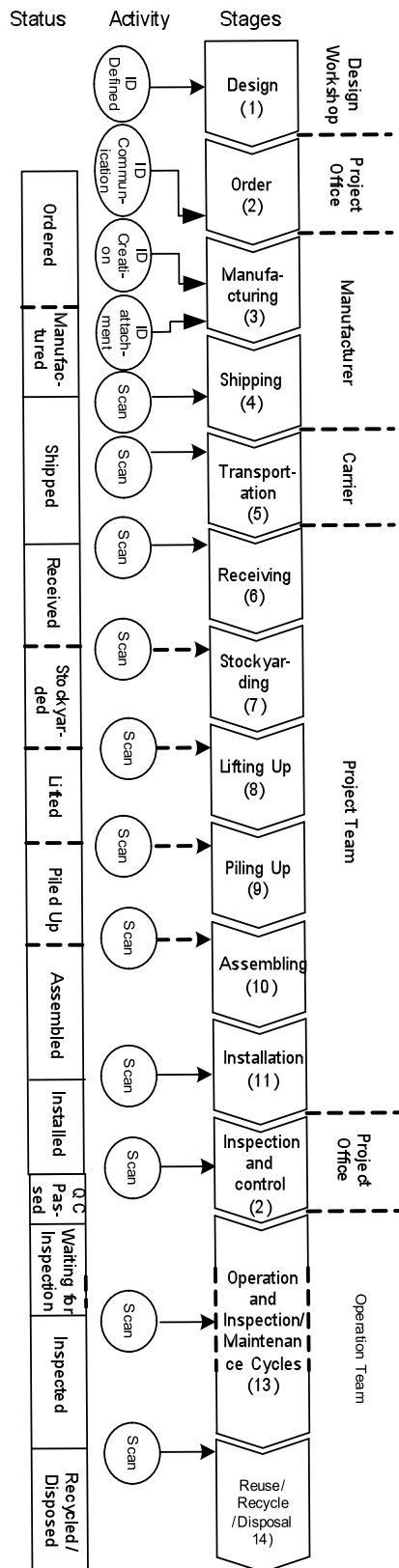

FIG 11: RFID-System activity timeline

(1) Design stage: A unique and standard ID is assigned to each component.

(2) Ordering stage: The ID of a component is communicated in the ordering stage to the manufacturer. By sending the order, the status is set to *ordered*.

(3) Manufacturing stage: The manufacturer produces the ordered component, writes the ID on the appropriate tag and attaches the tag to the component. The tag is scanned in the manufacturing site and the data is communicated to the project office. Accordingly, the status of the component changes to *manufactured*.

(4) Shipping stage: The component is scanned before being shipped and its status is changed to *shipped* based on the information from the carrier.

(5) Transportation: the component is scanned by the carrier while loading and the status is changed to *transported*.

(6) Receiving stage: When a component is received in the site, it is inspected and scanned, and the status of the component is changed to *received*. After this stage, based on the type of the component, it will be stored, lifted up or directly installed.

(7,8,9) Stockyarding, lifting up, piling up stages: In all these stages the component is scanned and the status information is automatically changed.

(10) Assembling stage: for the components that need to be assembled on the floor before final installation, the status is recorded after assembly process.

(11) Installation stage: the workers change the status of the components to *installed* after final installation. By finishing the installation, the finish date for the task associated with the component in the scheduling software would be updated. The exact information about the finish date of the task would improve the data accuracy of progress measurement.

(12) Inspection and quality control stage: The inspection and quality control will be done after installation, the component is scanned during the inspection and the status is changed to *QC passed*.

(13) Operation and maintenance stage: the component may have several statuses in its operation stage. There might be cycles of inspection, maintenance or repair needed for the component. The general status for the components in their operation stage is *in service*. The components that need to be maintained and inspected regularly (e.g., HVAC system and other mechanical parts) are scanned by the maintenance team and the status is changed to *inspected*. During the maintenance stages the status of the components that are waiting to be inspected is changed to *waiting for inspection*.

(14) Reuse/recycle/disposal: based on the planned End of Life (EoL) decision by the PLM (Product Lifecycle Manager) software, the status is changed to *recycled/reused/disposed*.

The above activities timeline shows examples of RFID scans needed to change the status data on a component tag. Several other information can be read/updated on the same scan attempts (e.g., record the history data, read information from previous stage, update the process related info).

3.6 Examples of lifecycle location management using tag data

As explained above, by storing the information on the tags, real-time data access is provided for a computer system equipped with an RFID reader. Knowing that the location of some components is needed to be tracked in different stages, which is a labour intensive activity, having the exact location information of the component during the lifecycle would eliminate the lookup time for the components and increase efficiency.

The following location-related information could be recorded on the tags: (1) current location (for temporary, fixed and moving components), (2) final location when installed (for fixed components), (3) temporary location (location of the component in the yard or storage), (4) location of the other objects, (5) path and routing information, (6) location of the attaching parts, (7) location of the inside parts, and (8) disposal location.

The above location information are available in BIM and can be used by different software applications, such as Enterprise Resource Planning (ERP), project management, inventory management, Computerized Maintenance Management System (CMMS), supply chain management, and Product Lifecycle Management (PLM).

At the design stage, the ID and the final location of the component are created in the CAD and FM software and confirmed with the manufacturer in the ordering process. While the final location information is written on the tag at an early stage in the lifecycle, a variety of temporary location information is stored and used at various stages. Thus, in order to use relevant location information, series of read/write attempts have to be executed during the lifecycle. The following examples describe the potential applications of location information on the tags during different lifecycle stages.

Manufacturing stage

The manufacturer records ID and final location of the component on the tag (for the fixed components). The process-related memory space of tag can be used to store temporary location information in the manufacturing stage, such as storage location and delivery lot information. This location-related information can be used to facilitate locating the component in the manufacturer storage and can help assembling the parts.

Shipping and delivery stages

While shipping, the lot information of components can help the delivery personnel to make sure the parts are being shipped in the right lots and are located on the right truck or container. The readers at the gates would send the location information of the components and provide supply chain visibility. Moreover, the destination site can be recorded on the component to prevent human errors in the shipment process.

Receiving and stockyarding stages

While receiving at the site, the temporary storage or pile-up location can be recorded on the tags to facilitate the operations required for moving the components to their designated location on the site or on the floors. Moreover, the location information on the component tags would help the cranes or workers to find them more quickly.

Assembling and installation stages

The final location of the component, the instruction for installation and the location of attached parts help assembly and installation team to perform their work more quickly and more efficiently.

Operation and maintenance stages

After final installation the fixed components have their location information recorded on their tags. This information would help inspectors or maintenance personnel to find them by scanning the area. This feature would reduce the locating time for objects that are hidden or obstructed. The tags may contain the information about the adjacent objects in the constructed facility which is helpful for finding these objects and paths. Moreover, the location information read from the tags would help the mobile user to locate himself in the area.

The tags may also contain floor plans and indoor routing information in the buildings that is helpful for navigation. By having access to such information, users can locate the exits and other spots of the building in the absence of any preloaded maps.

4. SCOPE OF IMPACT AND PROSPECTIVE VALUE ADDING BENEFITS

Implementation of the proposed approach can facilitate different processes during the lifecycle and can result in various value adding benefits by providing the needed information on the tags continuously throughout the lifecycle. The scope of impact in each process area is noted in the following.

Lifecycle management

Having product history and process related information stored on tags attached to components provides easy access to data for various PLM software applications and eliminates the need for network connectivity to retrieve data from a central database. Furthermore, it reduces human errors since the data storage/retrieval is automated in an electronic format which minimizes the risk of data loss.

Supply chain management

Attaching RFID tags to components provides the ability to remotely identify and track each component individually. This feature provides more accurate supply chain visibility and improves information sharing and reduces manual paper-based record tracking.

In addition, using RFID technology reduces material handling, inspection, receiving, and loading/unloading time during supply chain and reduces human errors from labour-intensive and error-prone operations such as counting and manual data entry. It increases data accuracy and improves inventory records (Tajima 2007). Moreover, Having accurate information on the tags has potential to improve the quality of supply chain management decisions, that have been made previously based on incomplete or less timely data (Lin et al. 2006).

Construction management

Ability to identify and locate building components remotely and having access to real time process data in the field would facilitate various operations on construction sites. It is also expected to facilitate progress monitoring by real-time and accurate measurement of activities. Moreover, the data on the tags can provide instruction for installation and assembling.

Quality engineering

By adding the installation and operation manuals on the tags or storing a unique link (e.g., URL or DoI) to access those instructions from a repository of manuals and guides, human errors in such activities are reduced and the process of installation and assembling will be unified for all components regardless of the operator. It also facilitates and improves the quality of inspection and maintenance processes by storing component history and inspection guides on the component. Furthermore, available and easy-to-access information about the component status and history provides easier, faster and more accurate quality control ability.

End-of-Life management

End-of-Life (EoL) management involves those options available to a product after its useful life (Parlikad 2003). Thierry et al. (1998) illustrates five product recovery operations, aimed at recapturing value from EoL products that are: repair and reuse, refurbishing, remanufacturing, cannibalisation and recycling. Parts and materials that could not be recovered by any of the above five operations will be disposed in accordance with safety and environmental regulations.

The appropriate EoL method is chosen base on the information about the component materials, parts and environmental factors. The proposed approach provides the necessary information on the tag to support EoL decision making process.

Reverse manufacturing

The operations related to the handling of waste generally involve reverse manufacturing, which transforms the end of life product/assembly into its components. Other operations include various recycling processes that recover reusable materials from the separated components based on the material composition of the components (Zhang 2007). A fundamental obstacle to achieving more acceptable product recovery levels is that information associated with the product is often lost after the point of sale (Parlikad 2003). Storing component information on the tags will facilitate the reverse manufacturing of components at the end of their lifecycle.

Navigational aid

The location and routing information on the tag as discussed in Subsection 3.6 can provide navigational aid to facility users. By gathering the location and navigational information form the tags, the map or path plans are

drawn without having access to a database. In addition, the user with a portable reader can locate himself based on the location of the surrounding tags.

Safety

Safety information about the components, such as safety manuals and hazardous materials information, can be stored on the tags. In addition, safety information and guidelines about the spaces (e.g., rooms, corridors, and staircases) and emergency procedures can be stored on the tags that are available in the spaces. This would provide access to important information in emergency situations where all the other information access methods are unavailable. In addition, facilitating the maintenance and repair management would directly affect the safety measures of buildings.

5. CHALLENGES

Although the proposed approach can be implemented using available hardware, due to high implementation and customization costs, it is not financially feasible at present. Further development in the following areas would lead to less expensive hardware solutions and more robust, industry-wide standards and low-cost supporting software applications. The challenges can be categorized under the following main topics: (1) challenges related to adopting RFID technology, (2) challenges in extending BIM and its implementation, (3) technology adoption and social challenges, and (4) process related challenges.

(1) Challenges related to adopting RFID technology

There are several challenges in adopting RFID technology that can be grouped as the following:

RF challenges: Technological challenges are related to the effects of materials such as liquids or metal on electromagnetic waves that interfere with the operation of the RFID system and shorten the readability range. Moreover, radio signals transmitted simultaneously by different tags cause collision lowering the quality of transmission and increasing the error rate.

Standards: The lack of a complete and international standard is another major issue in wide adoption of RFID systems. In addition, vendors are concerned with the high patent royalty which becomes an obstacle to the development of RFID systems (Chao et al. 2007).

Cost: Currently the cost of manufacturing and customization of tags is high. In addition, RFID systems require infrastructure to interconnect all the stakeholders to be able to communicate electronically. This infrastructure requires tremendous amount of design and implementation efforts. On the other hand, the intangible benefits of implementing RFID systems make the cost-benefit and ROI (Return on Investment) analysis more complicated.

Furthermore, barcode systems have been already implemented by many enterprises. RFID is still at developing stage; therefore, enterprises will keep two systems to operate. This will incur a double cost of maintenance of two systems for operation (Chao et al. 2007).

Security: Data Security and data privacy are considered as major concerns in adopting RFID technology. More advanced reader authentication and data protection techniques are required for implementing the proposed approach.

Ruggedness: Tags that can operate in harsh environments are needed for the construction industry. Since the tags are attached to components throughout the lifecycle, proper physical protection (e.g against temperature and material effects) is needed.

Data transfer speed: The RFID system must support high data transfer speed in order to be able to access all the information in short period of time. The low data communication rate of low frequency standards would decrease the expected efficiency of the proposed approach.

Interoperability: The wide implementation of RFID systems requires more standards to cover all types of tags and frequencies. Moreover, the need for multi-protocol tags and readers is evident for interoperability of different systems.

Power: Limited lifetime of battery-assisted tags is a challenge that should be addressed. Hence, low power RFID systems should be further developed.

Environment: Environmental issues should be considered in manufacturing the tags by using new materials.

(2) Challenges in extending BIM and its implementation

The efforts for developing BIM standards are in their early stage and the available standards and implementation of BIM-based systems are not complete and thorough. As discussed in Subsections 2.2 and **Error! Reference source not found.**, there is an evident need for further development of BIM standard in order to extend the procedures and descriptions to the whole lifecycle of facilities. Moreover, the information flow between the stakeholders should be designed and data handover methods and lifecycle data management techniques should be further explored.

Adopting BIM standards has its own challenges and obstacles; issues such as industry acceptance, interoperability between existing software platforms, change management from conventional methods to new BIM, qualified human resources, legal considerations and initial cost to change (hardware, software, training and implementation) have to be tackled for industry-wide implementation of BIM.

(3) Technology adoption and social challenges

Wide Implementation of such systems would bring resistance from companies that are using traditional methods because of needed extra efforts and training. Hence, it is important to provide strong incentives for enterprises for adoption of new technologies.

(4) Process related challenges

The operation and maintenance processes involved in building lifecycle should be reviewed and re-engineered considering new opportunities. The barcodes can be replaced with RFID tags where feasible, but due to technological and application difference between barcode and RFID, the processes should be reconsidered and adopted to RFID technology. In addition, the existence of level one intelligence in the components brings about invaluable opportunities to process designers; hence profit-making procedures and subsystems should be designed and engineered.

6. CASE STUDIES

6.1 Case Study 1: Progress management and 4D visualization

This case study is designed to facilitate the process of progress monitoring of construction projects and to provide visualisation aid for component status tracking. The result of implementing the case study is accurate progress measurement data resulting in accurate 4D model and 3D visualization of building component based on their status.

The prototype system is composed of six subsystems: (1) the database that store the data extracted from the BIM, which will be updated by RFID reads and other software updates (e.g., inspection data), (2) the 3D modeling software that stores the data in IFCxml format, (3) the scheduling software, (4) the 4D simulation software, (5) the FM software, and (6) the RFID reader interfaces. The communications between the subsystems are based on standard protocols providing scalability and interoperability. The software components and the relationship between them are shown in Fig. 12. The structure proposed for the database includes fields such as: ID, design code, status, type, ordering date, manufacturing date, shipping date, receiving date, stockyarding date, piling-up date, lifting-up date, assembling date, installation date, quality control date, task start, task finish, last inspection date and next inspection date. The 4D simulation software obtains the geometrical information from the 3D software and the timing and status information from the database to produce different real-time views of the facility using a predefined colouring scheme. These views help project managers and the FM team to better visualize the status of the facility.

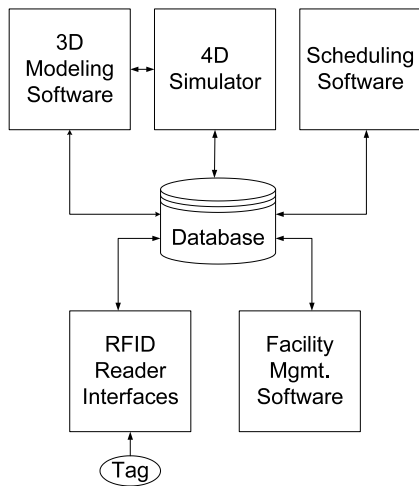

FIG. 12: System structure

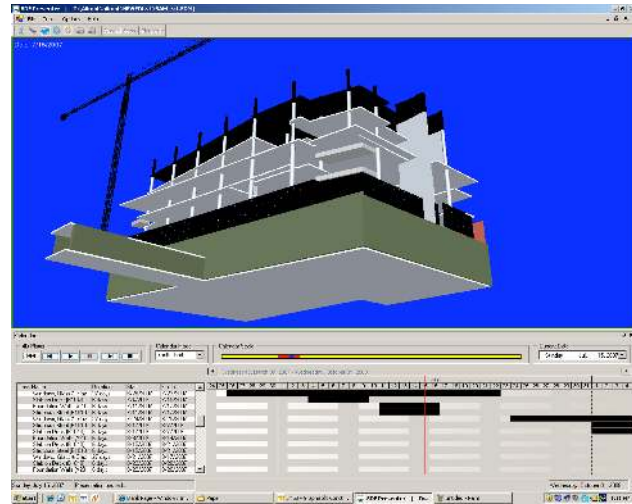

FIG. 13: 4D simulation of the JMSB project

I

In this study, we focused on the progress monitoring and lifecycle management of the HVAC components in the new building of John Molson School of Business (JMSB) at Concordia University. The construction project is a high-rise building located in downtown Montreal. Graphisoft suite is used for 4D modelling and scheduling (Graphisoft 2008). The main software in the suit, *Constructor*, is a complete package for building construction models and linking them with scheduling applications. The other used software packages are *Control* for scheduling and *5D Presenter* for progress simulation. Microsoft Project is also used for schedule management and progress monitoring. The RFID reader interface is used for entering data into the database. Various Identec Solution (Identec 2008) active RFID tags are used. The tags operate in UHF frequency and have 8 or 32 KB of memory.

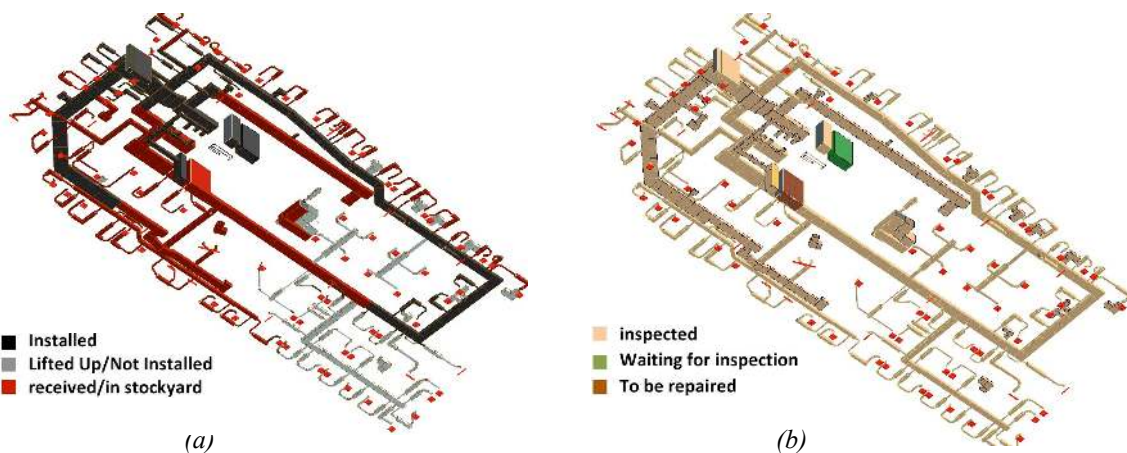

FIG 14: HVAC 3D drawing of one floor of the JMSB building:
 (a) Construction Phase, (b) Maintenance Phase

Fig. 13 shows the 4D simulation of the JMSB project, the anticipated task durations are based on the initial planned schedule, and the actual durations for finished tasks are updated using the database. Fig. 14 shows sample snapshots of 4D visualization of the HVAC system on the 14th floor of the building. Fig. 14(a) shows the status of the components during the construction phase. The components that are installed are shown in black. The components that are lifted up but not yet installed are shown in red. The components that are in the stockyard and have not been lifted up are shown in grey. Fig. 14(b) shows the status visualization during the operation phase. The component in green is waiting for inspection and the component in dark brown needs to be repaired based on the database status. The exact number and types of the needed tags and the precise location of attaching the tags should be designed and tested for different components in our future research.

6.2 Case Study 2: Fire equipment inspection and maintenance

In this case study, RFID tags are used for storing information about fire safety equipments. Amongst all safety related equipments, fire extinguishers and safety valves are chosen because of their importance and the higher frequency of their maintenance activities. In this case study, all the required software modules have been developed and the applicability of the RFID-based system has been tested by several field experiments.

Fire extinguishers should be regularly inspected, maintained, recharged and tested based on National Fire Protection Association (NFPA) regulations and guidelines. Strict safety regulations of sensitive systems in buildings, such as fire related subsystems, force the owners to spend huge amount of money to perform inspection on a regular basis.

The safety regulations require the extinguishers to be removed from their place and be taken to a repair shop for recharging and hydrostatic testing. At the same time it is mandated to have extinguishers at all designated place. Thus, these requirements complicate the process of inventory tracking. Consequently the prospective number and the location of the extinguishers that need to be recharged/replaced are considered very valuable information for management and planning. Moreover, reduction of human errors in the management of safety related components is crucial and the processes designed for maintenance of such systems should satisfy the requirements for reliability.

The results of inspection and maintenance should be stored and be readily available for owners and insurance companies. However, this information is usually poorly structured and delivered in paper format by contractors. The results are not up-to-date and the supervision over the inspection and maintenance activities is not satisfactory.

Barcodes have been used to facilitate the maintenance and inventory tracking of the extinguishers and fire valves. The barcodes are used to quickly lookup the ID in the database without manual entry. In the currently used system at Concordia University, barcodes are used to facilitate the maintenance and inventory tracking of extinguishers and fire valves by automatically searching their IDs in a spreadsheet without manual entry.

In our prototype system, crucial information is stored on tags attached to the extinguishers and valves. This would provide the information about the history and the condition of the extinguishers and valves for inspectors and maintenance/ repair personnel without access to any central database. Thus, it provides data redundancy and eliminates the rework due to none-up-to-date data.

Two different types of tags have been tested and used in the prototype system: Active tags with 8 or 32 KB of memory and standard passive tags with 96 bits of memory. The active tags are long range but the passive tags have the readability range of few inches for a typical handheld reader. The selected tags are designed to be attached to the components throughout their lifecycle. Hence, they are rugged and have large number of allowed read/write cycles. Moreover, the selected tags are designed to work well near liquids and metals.

Short write distance for tags would guaranty that the inspector did the inspection and maintenance activity in close proximity of valves and, that he lifted and displaced the extinguishers in order to update the data. Furthermore, the software will not allow the inspector to finish the task unless the record is updated on the tag. This provides fraud prevention for maintenance activities and increases the reliability.

The memory of the tags has been segmented and contains to the following information: (1) ID, (2) Specification (e.g., manufacturing date), (3) Status, (4) Maintenance data (e.g., condition and defective part), (5) History (e.g., last inspection date) and, (6) Environment data (e.g., location). Table 2 shows the data structure for the passive tags attached to fire extinguishers.

Table 2 Tag data structure for fire extinguishers

ID			DATA																	
Type	Model	Serial	Manufacturing Date	Specification	Status	Maintenance data											Environment Data			History
						Obstructed	Pressure High	Pressure Low	Condition					Defective part					Building	
Overall	Loose	Dusted	Rusted	Damaged	Missing Pin				Missing Rivet	Missing Paper	Missing Sign	Neck Bended	Plugged Hose	Seal Broken						

Due to the limited memory of passive tags, the above information is squeezed to binary codes and stored on the tags. The software translates BIM data related to components to codes using lookup tables and store codes in designated memory spaces on the tags. The main data is stored in a MySQL database as well as ifcXML representation of BIM.

The information about the defective parts that is written on the tag helps maintenance workers to quickly identify the problem based on the previous inspection and decreases the re-work.

The developed software contains the RFID reader interface to communicate with different readers (active and passive) and the middleware that communicates with the database and the user. The user interface provides wizards for the inspector which contains standard instructions for inspection, alerts and customized data entry dialogue boxes based on the type of component. By having the information that is read from the tag combined with the hardcoded instruction, wizards and alerts, less experienced inspectors can perform the job without increasing human errors.

The software also provides navigation aid for the inspector to locate the extinguishers and valves in the building using active tags. The software has pre-loaded floor plans as a visualization layer. By surveying the area to detect the tags, the sensed tags are shown on the floor plan based on their location information. Using the long range tags allows inspectors to visually find the surrounding components on the floor plan and decreases the time needed to locate them. Fig. 15 shows a sample snapshot of the screen, where the locations of sensed components are shown with red stars on the floor plan and it helps the user to visually identify the components on the plan.



FIG. 15: Snapshot of location management software

This case study has been done in a pilot scale in EV building of Concordia University where active and passive tags were attached to 9th floor fire valves and extinguishers. The technological feasibility of the system has been tested in a real working environment. The full implementation of the proposed system is being proposed to the FM department for all the buildings at Concordia University.

7. ROADMAP FOR SMART BUILDING LIFECYCLE MANAGEMENT

Hannus et al. (2003) and Hannus (2007) provided "Construction ICT Roadmap" with the objective of developing a vision of ICT (Information and Communication Technology) support in the construction sector and to form a strategy for future research and development towards the vision. According to the roadmap, the vision for future ICT in construction is defined as: "Construction sector is driven by total product life performance and supported by knowledge-intensive and model based ICT enabling holistic support and decision making throughout the various business processes and the whole product lifecycle by all stakeholders". The proposed roadmap focuses on new and emerging ICTs and indicates opportunities for the industry to take up existing technologies. Twelve different visions have been identified in the roadmap. The report provides the "subroadmap" diagrams which discuss the following steps toward different visions at different time spans: (1) Take-up: Adopt, deploy & demonstrate mainly existing technologies (0-2 years); (2) Development: Clearly defined R&D to achieve exploitable results (3-5 years); (3) Research: Prototyping is required to find the way forward (6-10 years); and (4) Emerging: Exploring R&D needs and opportunities for potential solutions (11-20 years). These diagrams provide a high level view of the directions for future R&D in construction.

Our proposed research ultimately suggests adding levels of intelligence to building components during their lifecycle. We call this vision *smart building lifecycle management*. It involves a broad range of ICT technologies and areas. The roadmap toward this vision is the combination of several steps that were introduced in "subroadmaps" under several different visions in the Construction ICT Roadmap. The most related visions are: digital site, ambient access, smart building, total lifecycle support, and flexible interoperability. The *smart building lifecycle management* is a logical extension of the above five visions because its full realization requires achieving all these visions as shown in Fig.16. This figure provides the overall view about the logical paths toward *smart building lifecycle management* and the areas that requires further development for realizing the proposed approach. Subsections 3.5 and 3.6 provided several examples of *smart building lifecycle management* for lifecycle status tracking and location management. Section 4 provided scope of impact and prospective value adding benefits. While Section 6 provided two specific case studies. It is interesting to notice here how the proposed new vision fits well with the previous ones and its added value in bringing the synergy among them by linking two key available technologies, i.e., RFID and BIM.

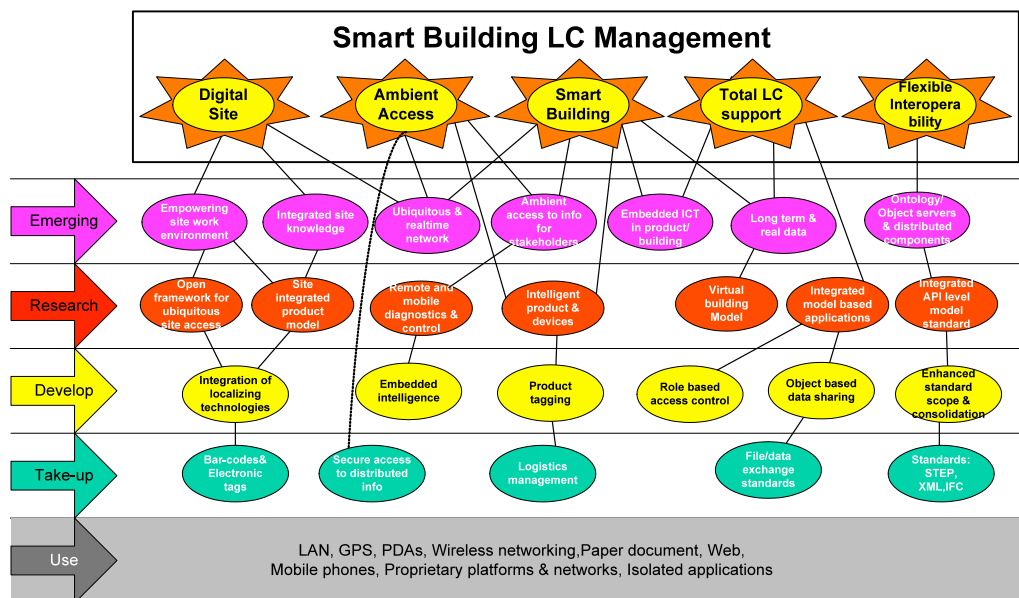

FIG. 16: Roadmap for smart building lifecycle management (adopted from Hannus et al. 2003)

8. CONCLUSIONS AND FUTURE WORK

The proposed methodology provides conceptual data structure and implementation approach of a futuristic vision of facilities with RFID tags attached to their components where BIM lifecycle data would be continuously updated. Although the case studies show the technical feasibility of the proposed framework using available hardware, several challenges should be addressed to make the vision practical and financially feasible.

The following steps are necessary for realizing the proposed approach: (1) identifying most suitable building components for tagging based on cost-benefit analysis considering long-term value adding benefits, (2) re-engineering existing construction and maintenance processes for the selected components, (3) investigating product-specific and detailed tag structure for the selected components, (4) extracting important *process data* to be stored on the tags for each lifecycle stage of selected components, (5) technology selection and field testing for available RFID hardware, and (6) investigating new information to be added to BIM related to RFID.

9. ACKNOWLEDGMENTS

The authors would like to acknowledge the contributions of Mr. Ziad Nahas and Capstone project team for developing the RFID-aided inspection application and performing several field tests, Mr. Rakesh Saini for developing the location management application, Mr. Basim El-Hamwi for developing the 3D model of JMSB building, and Mr. Ayham Krayem for adding the HVAC system to the 3D model. Data collection and execution of case studies could not be done without the information provided by Concordia University Facilities Management Office. The cooperation of Mr. Jean Rivard on JMSB construction site, Mr. Gilles Desrochers from Genivar, Mr. Gerry Gallant in fire equipment inspection project and Mr. Normand Lanthier from Environmental Health and Safety Office is also appreciated.

10. REFERENCES

- Akinci B., Patton M. and Ergen E. (2002). Utilizing radio frequency identification on precast concrete components—supplier's perspective, *Proceedings of ISARC '02*, IAARC, Washington, DC, 381–386.
- Aimglobal (2008). What is RFID, Retrieved October 2008, from:
<http://www.aimglobal.org/technologies/rfid/what_is_rfid.asp>.
- Associated General Contractors Guide (2006). AGC Contractors' Guide to BIM, from:
<<http://www.agcnebuilders.com/documents/BIMGuide.pdf>>.
- Chao C., Yang J., and Jen W. (2007). Determining technology trends and forecasts of RFID by a historical review and bibliometric analysis from 1991 to 2005, *Technovation*, 27(5), 268-279.
- Chin S., Yoon S. W., Kim Y. S., Ryu J., Choi C. and Cho C. Y. (2005). Realtime 4D CAD + RFID for project progress management, *Proceedings of Construction Research Congress*, San Diego, California, USA.
- Chin S., Yoon S., Choi C. and Cho C. (2008). RFID + 4D CAD for progress management of structural steel works in high-rise buildings, *Journal of Computing in Civil Engineering*, 22(2), 74-89.
- Construction Industry Institute (CII) (1986). Project Control for Engineering, Publication 6-1, The Construction Industry Institute, University of Texas at Austin, Austin, Texas.
- Domdouzis K., Kumar B. and Anumba C. (2007). Radio-frequency identification (RFID) applications: A brief introduction, *Advanced Engineering Informatics*, 21(4), 350-355.
- East W. E. and Brodt W. (2007). BIM for Construction Handover, *Journal of Building Information Modeling*, 28-35.
- East W. E. (2008). Construction operations building information exchange (COBIE). Retrieved October 2008, from: <<http://www.wbdg.org/resources/cobie.php>>.
- EPCglobal (2008). EPCglobal tag data standards version 1.4, EPCglobal, from:
<http://www.epcglobalinc.org/standards/tds/tds_1_4-standard-20080611.pdf>.
- EPoSS (2008). Internet of things in 2020 - A roadmap for the future. European Technology Platform on Smart Systems Integration.
- Ergen E., Akinci B., East B. and Kirby J. (2007a). Tracking components and maintenance history within a facility utilizing radio frequency identification technology, *Journal of Computing in Civil Engineering*, 21(1), 11-20.

- Ergen E., Akinci B. and Sacks R. (2003). Formalization and automation of effective tracking and locating of precast components in a storage yard, *Proceedings 9th EuropIA International Conference*, EIA9: E-Activities and Intelligent Support in Design and the Built Environment, Europa, Istanbul, 31-37.
- Ergen E., Akinci B. and Sacks R. (2007b). Life-cycle data management of engineered-to-order components using radio frequency identification, *Advanced Engineering Informatics*, 21(4), 356-366.
- Ergen E., Akinci B. and Sacks R. (2007c). Tracking and locating components in a precast storage yard utilizing radio frequency identification technology and GPS, *Automation in Construction*, 16(3), 354-367.
- FIATECH (2008). Report Documents Materials and Asset Tracking Using RFID, Retrieved October 2008, from: <<http://www.fiatech.org/news/10-08-04.html>>.
- Furlani K.M., Pfeffer L. E. and Stone W.C. (2000). Automated part tracking on the construction job site, *Proceedings of the Robotics 2000— ASCE Conference on Robotics for Challenging Environments*, Albuquerque, N.M.
- Furlani K.M. and Pfeffer L.E. (2000). Automated tracking of structural steel members at the construction site, *Proceedings ISARC '00*, IAARC, Taipei, 1201-1206.
- Furlani K.M. and Stone W.C. (1999). Architecture for discrete construction component tracking, *Proceedings ISARC '99*, IAARC, Madrid, 289-294.
- Gallaher M.P., O'Connor A.C., Dettbarn J.L. and Gilday L.T. (2004). Cost analysis of inadequate interoperability in the US capital facilities industry, NIST Publication GCR 04-867, from: <<http://www.bfml.nist.gov/oaepublications/gcrs/04867.pdf>>.
- Ghanem A.G. and AbdelRazig Y. A. (2006). A framework for real-time construction project progress tracking, *Earth and Space 2006*, (188)112.
- Graphisoft R&D zrt. (2008). from: <<http://www.vicosoftware.com/>>.
- Goodrum, P. M., McLaren, M. A. and Durfee, A. (2006). The application of active radio frequency identification technology for tool tracking on construction job sites, *Automation in Construction*, 15(3), 292-302.
- Hammad A. and Motamedi A. (2007). Framework for lifecycle status tracking and visualization of constructed facility components, *Proceedings of the 7th International Conference on Construction Applications of Virtual Reality*, October 23-24, Penn State University, University Park, PA.
- Hannus M. (2007). FIATECH capital projects technology roadmap, ECTP FA PICT, from: <http://www.fiatech.org/pdfs/projects/fiatech_ectp_mapping.pdf>.
- Hannus M., Blasco M., Bourdeau M., Bohms M., Cooper G., Garas F., Hassan T., Kazi A. S., Leinonen J., Rezgui Y., Soubra S. and Zarli A. (2003). Construction ICT roadmap. IST-2001-37278, from: <http://cic.vtt.fi/projects/roadcon/docs/roadcon_d52.pdf>.
- Harrison M. and Parlikad A. K. (2006). Lifecycle ID and lifecycle data management, AUTO-ID Labs, AEROID-CAM-005, from: <<http://www.autoidlabs.org/single-view/dir/article/6/264/page.html>>.
- Harrison M. (2007). Guidelines for lifecycle ID & data management, AEROID-CAM-014, from: <http://www.aero-id.org/research_reports/AEROID-CAM-014-Lifecycle.pdf>.
- Identec (2008). Identec Solutions, from: <<http://www.identecsolutions.com/>>.
- IDM 2007, Information Delivery Manual, from: <<http://www.iai.no/idm/index.html>>.
- Ifc-mBomb (2004). Ifc Model Based Operation and Maintenance of Buildings, Retrieved October 2008, from: <http://cig.bre.co.uk/iai_uk/iai_projects/ifc-mbomb/>.
- Isikdag U., Aouad G., Underwood J. and Wu S. (2007). Building information models: A review on storage and exchange mechanisms, Bringing ITC Knowledge to Work, 24th W78 Conference, Maribor.
- Isikdag U., Underwood J. and Aouad, G. (2008 accepted). An investigation into the applicability of building information models in geospatial environment in support of site selection and fire response management processes, *Advanced Engineering Informatics*, In Press, Corrected Proof.

- Jaselskis E. J., Anderson M. R., Jahren C. T., Rodriguez Y. and Njos S. (1995). Radio-frequency identification applications in construction industry, *Journal of Construction Engineering and Management*, 121(2), 189-196.
- Jaselskis E. J. and El-Misalami T. (2003). Implementing radio frequency identification in the construction process, *Journal of Construction Engineering and Management*, 129(6), 680-688.
- Khemplani L. (2004). The IFC building model: A look under the hood, AECbytes, Retrieved October 2008, from: <<http://www.aecbytes.com/feature/2004/IFCmodel.html>>.
- Kiziltas S., Akinci B., Ergen E. and Tang P. (2008). Technological assessment and process implications of field data capture technologies for construction and facility/infrastructure management, *ITcon*, Special Issue Sensors in Construction and Infrastructure Management, (13), 134-154.
- Legner C. and Thiesse F. (2006). RFID-Based Facility Maintenance at Frankfurt Airport. *IEEE Pervasive Computing*, 5(1), 34-39.
- Lin D., Barton R., Bi H. and Freimer M. (2006). Challenges in RFID enabled supply chain management, *Quality Progress*, 39 (11), 23-28.
- McCarthy J.F., Nguyen D.H., Rashid A.M. and Soroczak S.(2003). Proactive Displays & The Experience UbiComp Project, *Adjunct Proceedings of the Fifth International Conference on Ubiquitous Computing (UbiComp 2003)*, Seattle, 78-81.
- NBIMS (2005). Charter for the National Building Information Model (BIM) Standard, NIBS, from: <http://www.facilityinformationcouncil.org/bim/pdfs/NBIMS_Charter.pdf>.
- NBIMS (2007a). National Building Information Modelling Standard Part-1: Overview, Principles and Methodologies, US National Institute of Building Sciences Facilities Information Council, BIM Committee, from: <<http://www.facilityinformationcouncil.org/bim/publications.php>>.
- NBIMS (2007b). National Building Information Model Standard, Version 1, Part 1, from: <http://www.facilityinformationcouncil.org/bim/pdfs/NBIMsv1_ConsolidatedAppendixReferences_11Mar07_1.pdf>.
- Parlikad A. K., McFarlane D., Fleisch E. and Gross S. (2003). The role of product identity in end-of-life decision making, CAM-AUTOID-WH-017, Auto-ID Centre.
- Peyret F. and Tasky R. (2002). Asphalt quality parameters traceability using electronic tags and GPS, *Proceedings of ISARC '02*, IAARC, Washington, DC, 155-160.
- SAP (2005). SAP Mobile asset management at Fraport AG, from: <www.sap.com/solutions/mobilebusiness>.
- Scansource.com (2008). RFID frequencies, from: <http://www.scansource.com/europe/upload/RFID_Frequencies.pdf>.
- Schell D. (2001). Oil refinery uses RFID to eliminate rework and reduce data entry by 70% , *Business Solutions*, January 2001, Retrieved October 2008, from: <<http://www.businesssolutionsmag.com>>.
- Song J. (2005a). Tracking the location of materials on construction projects. Submitted in Partial Fulfilment of the Requirements for the Degree of Doctor of Philosophy, Faculty of the Graduate School of the University of Texas at Austin.
- Song J., Haas C.T., Caldas C. and Liapi K. (2005b). Locating materials on construction site using proximity techniques, *Construction Research Congress*, April 5-7, San Diego, US, 552-557.
- Song J., Haas C. T., Caldas C., Ergen E. and Akinci B. (2006a). Automating the task of tracking the delivery and receipt of fabricated pipe spools in industrial projects, *Automation in Construction*, 15(2), 166-177.
- Song J., Haas C. T. and Caldas C. H. (2006b). Tracking the location of materials on construction job sites, *Journal of Construction Engineering and Management*, 132(9), 911-918.
- Stephens J., Leonard D., Groom C. and Nisbet N. (2005). Life-cycle data for buildings: Opportunities for the IFC model based operation and maintenance (Ifc-mBomb), IAI UK Ltd.
- Thierry M.C., Salomon M., van Nunen J. and Van Wassenhove L. (1998). Strategic issues in product recovery management, *California Management Review*, 37 (2), 114-135.

- Tajima M. (2007). Strategic value of RFID in supply chain management, *Journal of Purchasing and Supply Management*, 13(4), 261-273.
- Umetani T., Arai T., Mae Y., Inoue K. and Maeda J. (2006). Construction automation based on parts and packets unification, *Automation in Construction*, 15(6), 777-784.
- Vanlande R., Nicolle C. and Cruz C. (2008). IFC and building lifecycle management, *Automation in Construction*, 18(1), 70-78.
- Wong C. Y., McFarlane D., Ahmad Zaharudin A. and Agarwal V. (2002). The intelligent product driven supply chain, 2002 IEEE International Conference on Systems, Man and Cybernetics, Yasmine Hammamet, Tunisia.
- Yabuki N. and Oyama T. (2007). Application of radio frequency identification technology for management of light weight temporary facility members, ASCE Workshop on Computing in Civil Engineering, Pittsburgh, 697-704.
- Yabuki N., Shimada Y. and Tomita K. (2002). An on-site inspection support system using radio frequency identification tags and personal digital assistants, *Proceedings of the 2002 CIB w78 Conference*, Aarhus School of Architecture.
- Yabuki N., Yamashita T., Shimada Y. and Sakata T. (2004). Application of RFID tags to an on-site inspection support system for large dams, *Proceedings of the third Civil Engineering Conference in the Asian Region*, Seoul, Korea, 397-400.
- Yagi J., Arai E. and Arai T. (2005). Parts and packets unification radio frequency identification (RFID) application for construction, *Automation in Construction*, 14(4), 477-490.
- Yoon S., Chin S., Kim Y. and Kwon, S. (2006). An application model of RFID technology on progress measurement and management of construction works, 23rd International Symposium on Automation and Robotics in Construction (ISARC), Tokyo, Japan.
- Zhang H. C., Li J., Shrivastava P., Whitley A. and Merchant, M. E. (2004). A web-based system for reverse manufacturing and product environmental impact assessment considering end-of-life, *CIRP Annals - Manufacturing Technology*, 53(1), 5-8.