

## REVIEW

# Light acts as a stressor and influences abiotic and biotic stress responses in plants

Venja M. Roeber  | Ishita Bajaj | Mareike Rohde | Thomas Schmülling  |  
Anne Cortleven 

Institute of Biology/Applied Genetics, Dahlem  
Centre of Plant Sciences (DCPS), Freie  
Universität Berlin, Berlin, Germany

## Correspondence

Dr. Anne Cortleven, Institute of Biology/  
Applied Genetics, Dahlem Centre of Plant  
Sciences (DCPS), Freie Universität Berlin,  
Albrecht-Thaer-Weg 6, D-14195 Berlin,  
Germany.  
Email: anne.cortleven@fu-berlin.de

## Funding information

Deutsche Forschungsgemeinschaft (DFG),  
Grant/Award Number: Schm 814/29-1 and  
Sfb 973

## Abstract

Light is important for plants as an energy source and a developmental signal, but it can also cause stress to plants and modulates responses to stress. Excess and fluctuating light result in photoinhibition and reactive oxygen species (ROS) accumulation around photosystems II and I, respectively. Ultraviolet light causes photodamage to DNA and a prolongation of the light period initiates the photoperiod stress syndrome. Changes in light quality and quantity, as well as in light duration are also key factors impacting the outcome of diverse abiotic and biotic stresses. Short day or shady environments enhance thermotolerance and increase cold acclimation. Similarly, shade conditions improve drought stress tolerance in plants. Additionally, the light environment affects the plants' responses to biotic intruders, such as pathogens or insect herbivores, often reducing growth-defence trade-offs. Understanding how plants use light information to modulate stress responses will support breeding strategies to enhance crop stress resilience. This review summarizes the effect of light as a stressor and the impact of the light environment on abiotic and biotic stress responses. There is a special focus on the role of the different light receptors and the crosstalk between light signalling and stress response pathways.

## KEYWORDS

abiotic stress, *Arabidopsis thaliana*, biotic stress, drought stress, light, light signalling, light stress, temperature stress

## 1 | INTRODUCTION

Sunlight provides plants with energy for photosynthesis and delivers information about the time of the day and the season. Light intensity and quality change constantly due to weather conditions (e.g., sunny or cloudy skies) and due to the sun's inclination causing seasonal shifts (e.g., spring with canopy closure) (Casal, 2013). Therefore, perception of light quality and quantity and adequate responses are essential for the plants' survival – not only during adverse light environments, but also to respond appropriately to other abiotic and

biotic stress responses. Furthermore, due to climate change, plants are more often confronted with adverse environmental conditions which results in decreased plant fitness and may consequently lead to a reduction of food and feed production for crop plants. An increasing number of studies report on the plants' use of light information to influence the outcome of diverse abiotic and biotic stresses. Knowledge about the crosstalk between light signalling and defence mechanisms might support the development of crops that optimally use the light information and are more stress resistant in times of global warming.

This is an open access article under the terms of the Creative Commons Attribution-NonCommercial License, which permits use, distribution and reproduction in any medium, provided the original work is properly cited and is not used for commercial purposes.

© 2020 The Authors. Plant, Cell & Environment published by John Wiley & Sons Ltd.

Plants possess two different systems to perceive environmental light information, photoreceptors and chloroplasts. Both systems are involved in regulating plant stress responses and will be briefly introduced in the following paragraphs. However, this review will mainly focus on the photoreceptors. Readers may refer to Fernandez and Strnad (2008); Crawford, Lehotai, and Strand (2018) and Zhang, Zhang, Li, and Lu (2020) for a broader description of the role of plastids in responses to stress.

Different parts of the solar light spectrum are sensed by specific photoreceptors (for review, see Paik & Huq, 2019). In *Arabidopsis thaliana*, red/far-red light is perceived by phytochromes (phyA to phyE), blue light by cryptochromes (CRY1, CRY2 and CRY3), phototropins (PHOT1, PHOT2) and F-box containing flavin-binding proteins (ZEITLUPE, FKF1/LKP2), and UV-B light by the UVR8 receptor. An overview of the most important photoreceptors and their signalling cascades in *Arabidopsis* is given in Figure 1.

Phytochromes predominantly absorb red and far-red light (Figure 1). Their photosensory activity is the result of a light-induced, reversible switching between the inactive red light-absorbing (Pr)-form and the active far-red light-absorbing (Pfr)-form. Photo-activated phytochromes repress the activity of SUPPRESSOR OF PHYA1/CONSTITUTIVE PHOTOMORPHOGENIC1 (SPA1/COP1), an E3 ubiquitin ligase. SPA1/COP1 degrades the ELONGATED HYPOCOTYL5 (HY5) transcription factor essential for the light-dependent transcriptional regulation of plant responses (Liu et al., 2015; Shin et al., 2013). Active phytochromes mediate the degradation of PHYTOCHROME INTERACTING FACTORS (PIFs) which repress photomorphogenesis (Li, Li, Wang, & Deng, 2011). Phytochromes are involved in shade avoidance, the regulation of seed germination, photomorphogenesis, flowering time, the circadian clock and gravitropism (Casal, 2013; Correll et al., 2003; Franklin & Whitelam, 2007b; Lin, 2000; Nagy & Schäfer, 2002; Pierik & de Wit, 2014; Somers, Devlin, & Kay, 1998).

Blue/UV-A light is perceived by cryptochromes (Figure 1) which contain a flavin adenine dinucleotide (FAD) as chromophore (reviewed in Wang & Lin, 2020). The cryptochromes are activated through interconversion of flavin redox states (Bouly et al., 2007) caused by photoexcitation (Liu, Liu, Zhao, Pepper, & Lin, 2011) resulting in the production of small amounts of reactive oxygen species (ROS) in the nucleus (El-Esawi et al., 2017). Two different ways of CRY-mediated signal transduction have been discovered (reviewed in Wang & Lin, 2020): the cryptochrome-interacting basic helix-loop-helix1 (CIB1)-dependent CRY2 regulation of transcription (Liu et al., 2008) and the SPA1/COP1-dependent proteolysis (Liang et al., 2018). Both pathways depend on direct interaction between CRYs and these signalling components to modulate gene expression or protein stability (Liu et al., 2011). Recently, it was found that blue light inhibitors of cryptochromes 1 (BIC1) and BIC2 inhibit cryptochrome function by blocking blue light-dependent cryptochrome dimerization (Wang et al., 2017). CRY1 and CRY2 mediate several responses such as the inhibition of hypocotyl elongation (Ahmad & Cashmore, 1993), root growth (Canamero et al., 2006), the regulation of the circadian clock (e.g., Devlin & Kay, 2000; Somers et al., 1998), flowering time (Guo, Yang, Mockler, & Lin, 1998), and stomatal development (Kang, Lian, Wang, Huang, & Yang, 2009).

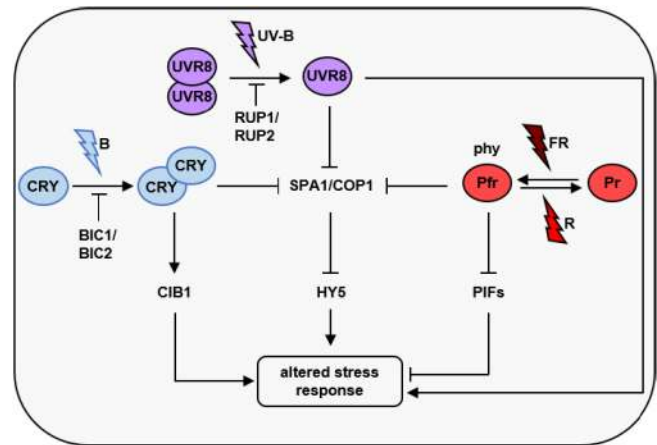

**FIGURE 1** Simplified scheme of the major light signalling pathways involved in responses to biotic and abiotic stresses. In plants, the UVR8 photoreceptor exists as a dimer and upon UV-B absorption, active UVR8 monomers interact with SUPPRESSOR OF PHYA1/CONSTITUTIVE PHOTOMORPHOGENIC1 (SPA1/COP1), an E3 ubiquitin ligase complex which degrades the ELONGATED HYPOCOTYL5 (HY5) transcription factor. The association of UVR8 and COP1 is disrupted by REPRESSOR OF UV-B PHOTOMORPHOGENESIS1 (RUP1) and RUP2 which induce re-dimerization. UVR8 can also directly bind to transcription factors regulating light or stress acclimation responses. Cryptochromes (CRY) represent blue-light-activated receptors. There are two different CRY-mediated signal transduction pathways: the cryptochrome-interacting basic helix-loop-helix1 (CIB1)-dependent regulation of transcription and the SPA1/COP1-dependent proteolysis. Both pathways depend on direct interaction between CRYs and their signalling components to modulate gene expression or protein stability in response to blue light. Blue light inhibitors of cryptochromes 1 and 2 (BIC1 and BIC2) inhibit cryptochrome signalling by blocking blue light-dependent cryptochrome dimerization. The photosensory activity of phytochromes (Phy) is the result of a light-induced, reversible switching between the inactive red light-absorbing Pr-form and the active far-red light-absorbing Pfr-form. Photo-activated phytochromes repress the activity of SPA1/COP1 releasing the degradation of HY5. Active phytochromes also mediate the degradation of PHYTOCHROME INTERACTING FACTORS (PIFs) which repress light responses. Abbreviations: B, blue light; UV-B, ultraviolet light, R, red light; FR, far-red light

Phototropins (PHOT) also absorb blue light (Gallagher, Short, Ray, Pratt, & Briggs, 1988) (Figure 1). They contain two photosensory light oxygen voltage (LOV) domains (Christie, Salomon, Nozue, Wada, & Briggs, 1999; Taylor & Zhulin, 1999) which function as a blue light sensor that is autophosphorylated upon blue light photoexcitation. This activates the C-terminal kinase domain, regulating in turn other proteins. PHOT1 and PHOT2 have partially overlapping functions such as phototropism, stomatal opening, chloroplast accumulation, and cotyledon and leaf expansion. In addition, PHOT1 is involved in regulating hypocotyl elongation and PHOT2 mediates chloroplast avoidance movement (Christie, 2007).

The ZEITLUPE (ZTL) family belongs to the LOV domain photoreceptors and includes ZTL, flavin-binding Kelch repeat F-BOX1 (FKF1)

and LOV Kelch protein2 (LKP2) (Ito, Song, & Imaizumi, 2012; Takase et al., 2011). They have overlapping roles in controlling stability of circadian clock components and in photoperiod control of flowering (Christie, Blackwood, Petersen, & Sullivan, 2015; Song et al., 2014).

The photoreceptor UV resistance LOCUS8 (UVR8) exists as a dimer and upon UV-B absorption, active UVR8 monomers interact with COP1 thus preventing the degradation of HY5 (Kliebenstein, Lim, Landry, & Last, 2002; Rizzini et al., 2011) (Figure 1). The association of UVR8 and COP1 is disrupted by REPRESSOR OF UV-B PHOTOMORPHOGENESIS1 (RUP1) and RUP2 which induce redimerization (Heijde & Ulm, 2013) thereby preventing UVR8-signalling. In addition to the UVR8/COP1/HY5 pathway, UVR8 can also directly bind to transcription factors, repressing brassinosteroid-promoted plant growth (Liang et al., 2018) and auxin-induced root branching (Yang et al., 2020).

Beside photoreceptors, chloroplasts can perceive light information via chlorophylls present in the light harvesting complexes in thylakoid membranes. Plants acclimate to their environment by dynamically adjusting the portion of light energy used to drive photosynthesis (Walters, 2005; Waters & Langdale, 2009). Depending on the light availability, plants modify the structure of the grana and change the relative ratios of chlorophyll *a* and *b* to optimize and protect photosynthesis and to protect the photosynthetic apparatus (Walters, 2005; Weston, Thorogoot, Vinti, & Lopez-Juez, 2000) from high light intensities. Chlorophylls act as shade sensors since they absorb very well in the red region of the light spectrum and not in the far-red region (Holmes & Smith). Furthermore, chloroplasts sense environmental changes. A complex plastid to nucleus signalling network (retrograde signalling) regulates nuclear gene expression to respond optimally to environmental stresses. As the role of retrograde signalling is not the main scope of this review, the reader may refer to Fernandez and Strand (2008) and Crawford et al. (2018) for more information.

In plant stress research, the regulatory functions of the main light signalling components have been underestimated for a long time. During the last years, an increasing number of interactions between light signalling pathways and stress responses have been discovered. For example, a recent review summarizes the modulation of stress responses by canopy light (Courbier & Pierik, 2019). Here, we give an overview on the effects of light as a stressor and the impact of the light environment (quantity, quality and duration) on biotic and abiotic stress responses. We especially focus on how the light signalling pathways are linked to stress response pathways. However, it should be noted that there are also stress responses independent of light that are crucial for plant survival under adverse environmental conditions. A summary of the key findings concerning the impact of light on abiotic and biotic stress responses presented in this review can be found in the Information Box.

## 2 | LIGHT AS A STRESSOR

Excess light can be harmful for plants and causes oxidative stress resulting in photodamage and photoinhibition (Ganguly, Crisp,

Eichten, & Pogson, 2018). Recurrent periods of excess light followed by lower light intensities (fluctuating light stress) result in strong stress responses just like the prolongation of the light period (photoperiod stress) (Nitschke et al., 2016). The ultraviolet

(UV) part of light leads to serious damage of DNA (Hideg, Janzen, & Strid, 2013). In the sections below, we describe the different mechanisms of plants evolved to cope with light stress with a special focus on the relevance of light signalling pathways (Figures 2–5).

### 2.1 | Excess light stress

Light intensity exceeding the energetic demand of photosynthesis causes damage to the photosynthetic machinery, especially to photosystem II (PSII), and thus causes photoinhibition (Figure 2). Protein D1, which is part of the reaction centre of PSII, is one of the main targets of photoinhibition (Edelman & Mattoo, 2008). The damaged D1 protein is removed and replaced by *de novo* synthesized proteins during the D1 repair cycle (Baena-Gonzalez & Aro, 2002). This process is highly dependent on the membrane fluidity of the thylakoid membranes (Yamamoto, 2016). When the rate of photodamage exceeds the D1 repair capacity, photoinhibition takes place.

Plants have developed several mechanisms to avoid photodamage to PSII (Takahashi & Badger, 2011). In response to direct sunlight, plants move their leaves (heliotropism) and chloroplasts group at cell walls parallel to the direction of the light to avoid absorption of excessive sunlight (chloroplast avoidance response). PHOT2, together with the CHLOROPLAST UNUSUAL POSITIONING1 (CHUP1) protein, are essential for the chloroplast avoidance response (Oikawa et al., 2003) (Figure 2). Screening against damaging radiation (UV and visible light) by phenolic compounds (Agati, Azzarello, Pollastri, & Tattini, 2012) helps plants to avoid damage to PSII and subsequent D1 protein degradation (Takahashi & Badger, 2011). When these avoidance mechanisms are insufficient, plants have to deal with the excess light absorbed by the photosynthetic pigments which generate ROS (Apel & Hirt, 2004) and result in oxidative stress. ROS trigger a direct inhibition of the D1 repair cycle (Takahashi & Murata, 2008). To avoid oxidative stress, plants reduce ROS by several ROS scavenging enzymes and antioxidants (Mittler, Vanderauwera, Gollery, & Van Breusegem, 2004). Plants dissipate excess light absorbed by the light-harvesting complexes as heat in a process called thermal energy dissipation (qE) which is part of the non-photochemical quenching mechanisms (NPQ) in plants (Holt, Fleming, & Niyogi, 2004) and can be activated by the generation of a pH gradient across the thylakoid membrane.

Excess light stress (Figure 2) leads to specific and dynamic transcriptional changes in gene expression (Li, Gao, Ren, & Tang, 2018). A recent study identified a core set of high light-responsive genes (Huang, Zhao, & Chory, 2019). The analysis revealed that plants respond to high light through regulation of hormones, photosynthesis and the phenylpropanoid pathway and that both abscisic acid and PIFs are required for the high light response (Huang et al., 2019). Moreover, it was shown that blue/UV-A photoreceptors are responsive to high light. The involvement of CRY1, in a chloroplast-

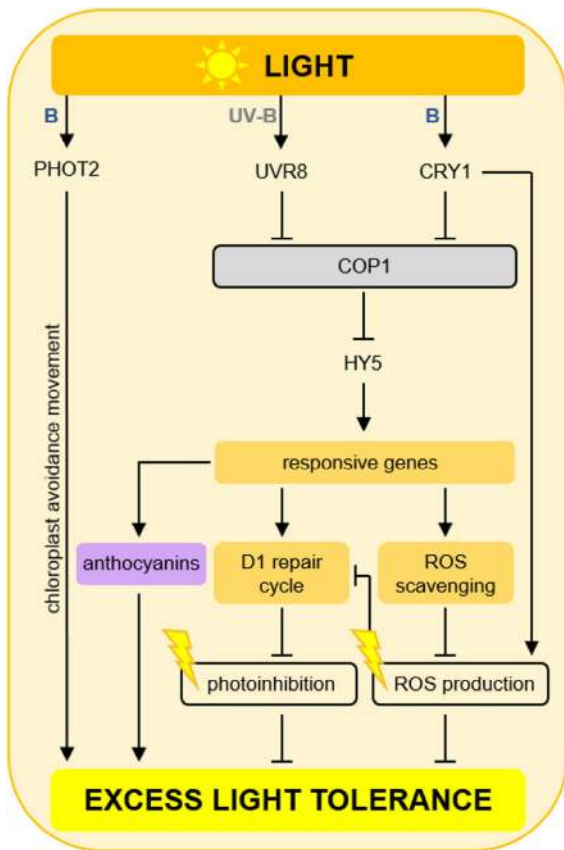

**FIGURE 2** Signalling pathways involved in the crosstalk between light and the response to excess light stress. Excess light stress results in photoinhibition and ROS production which are counteracted by the D1 repair cycle and reactive oxygen species (ROS) scavenging enzymes. Upon perception of excess light, responsive genes are induced resulting in the accumulation of anthocyanins and in an upregulation of genes involved in D1 repair and ROS scavenging. A specific role for blue light and UV-B, through CRY1 and UVR8 via COP1/HY5 has been shown to be involved in the regulation of excess light-responsive genes. Moreover, CRY1 itself, upon light perception, produces ROS by the interconversion of the flavin redox states caused by photoexcitation. Chloroplast avoidance movement mediated through PHOT2 also contributes to enhanced high light tolerance. For more detailed information about the different pathways, please refer to Section 2.1. Abbreviations: B, blue light; R, red light; UV, ultraviolet light [Colour figure can be viewed at [wileyonlinelibrary.com](http://wileyonlinelibrary.com)]

independent manner, was shown in an earlier study (Kleine, Kindgren, Benedict, Hendrickson, & Strand, 2007). Genome-wide gene expression analysis revealed that among the high light-responsive genes 77 are CRY1-dependent, and 25 were HY5-dependent. Both *cry1* and *hy5* mutants showed a misregulation of *EARLY LIGHT-INDUCIBLE PROTEIN1 (ELIP1)* and *ELIP2* whose induction is mediated via CRY1 in a blue light intensity-dependent manner (Kleine et al., 2007). Cryptochrome function during high light stress is connected to its direct interaction with the oxidative stress system. Especially, CRY1 activation is associated with ROS formation and is able to induce cell death in insect cells (Consentino et al., 2015; Jourdan et al., 2015).

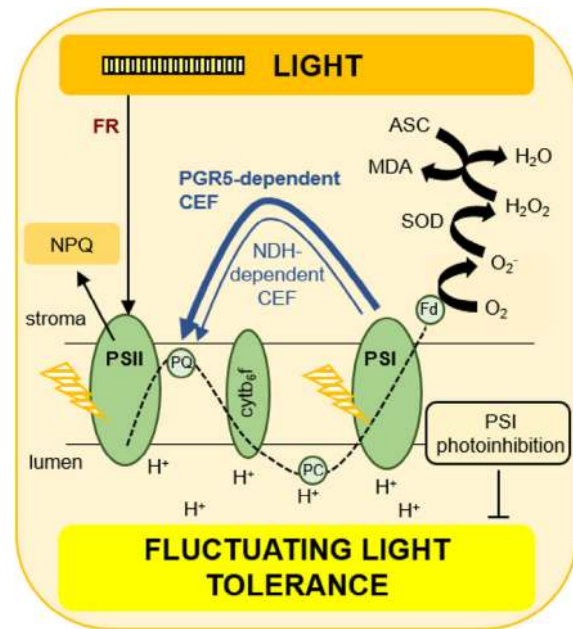
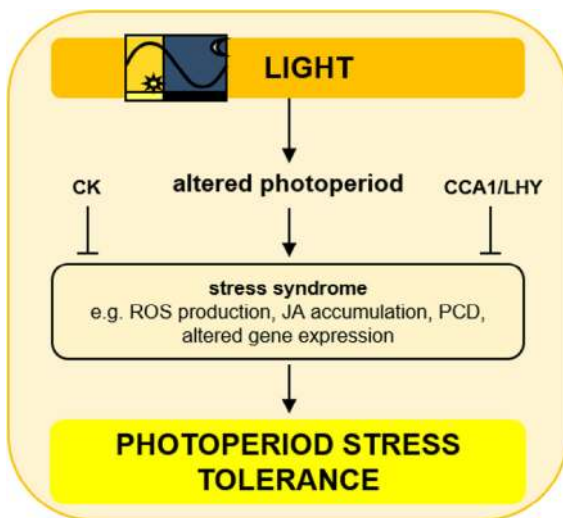

**FIGURE 3** Signalling pathways involved in the crosstalk between light and the response to stress caused by fluctuating light. Fluctuating light results in photosystem (PS) I photoinhibition. To deal with fluctuating light, plants developed alternative cyclic electron transport forces (CEF), of which the PROTON GRADIENT REGULATION5 (PGR5)-dependent CEF has a bigger role than the NADH-dehydrogenase-like complex-dependent (NDH)- CEF. Together with the Mehler and water–water cycle, these cyclic electron transport forces act as alternative electron sinks. All these mechanisms avoid PSI photoinhibition causing tolerance to fluctuating light. Only far-red (FR) light is known to ameliorate the energy dissipation via NPQ in PSII. For more detailed information about the different pathways, please refer to Section 2.2. Abbreviations: ASC, ascorbate; MDA, monodehydroascorbate; SOD, superoxide dismutase; PQ, plastoquinone; PC, plastocyanin; Fd, ferredoxin; *cytb<sub>6</sub>f*, cytochrome *b<sub>6</sub>f*; NPQ, non-photochemical quenching [Colour figure can be viewed at [wileyonlinelibrary.com](http://wileyonlinelibrary.com)]

In response to excess light, CRY1 is also involved in the accumulation of anthocyanins through the induction of *PRODUCTION OF ANTHOCYANIN1/2 (PAP1/PAP2)* (Kleine et al., 2007) in a COP1/SPA1/HY5-dependent manner (Maier & Hoecker, 2015). Growth of plants under blue/UV-A light prior to excessive light treatment revealed that CRYs ameliorate the response to high light stress by promoting the accumulation of soluble phenolic compounds in leaves and thus improving the photosynthetic efficiency (Brelford et al., 2019). A similar role with respect to flavonoid accumulation was also shown for UV-A and the UVR8 receptors (Brelford et al., 2019).

## 2.2 | Stress caused by fluctuating light

During the day, plants are exposed to fluctuations in the light environment (Figure 3) caused by shade in understory plants, by cloud movement or changes in sun elevation. Under fluctuating light, a fast switch from light absorption to heat dissipation (see Section 2.1) as in



**FIGURE 4** Signalling pathways involved in the crosstalk between light and the response to photoperiod stress. Photoperiod stress is caused by a prolongation of the light period resulting in a stress syndrome characterized by ROS production, jasmonic acid (JA) accumulation and eventually programmed cell death (PCD). Both cytokinin (CK) and CCA1/LHY are negative regulators of photoperiod stress. For more detailed information about the different pathways, please refer to Section 2.3 [Colour figure can be viewed at [wileyonlinelibrary.com](http://wileyonlinelibrary.com)]

constant high light is not possible due to slow NPQ relaxation (Kono & Terashima, 2014). Fluctuating light causes PSI photoinhibition due to a limitation of the electron flow on the acceptor side of PSI and an accumulation of ROS (Sonoike, 1996) which damages the iron-sulphur centres of PSI (Sonoike & Terashima, 1994). Since damaged PSI is not *de novo* repaired, PSI photoinhibition has to be avoided (Kudoh & Sonoike, 2002). Thus, plants developed short- and long-term acclimation responses (for review, see Kono & Terashima, 2014).

The short-term mechanisms include alternative electron transport flows (Figure 3). Among the two known cyclic electron transport flows around PSI are the NADH-dehydrogenase-like complex-dependent pathway (Shikanai, 2016) and the PROTON GRADIENT REGULATION5 (PGR5)-mediated pathway (Munekage et al., 2002). The latter is essential for the protection of PSI by improving the PSI acceptor-side limitation (Kono, Noguchi, & Terashima, 2014; Kono & Terashima, 2014, 2016). Similarly, the water-water cycle (Asada, 1999) and the Mehler ascorbate peroxidase pathway (Schreiber, Hormann, Asada, & Neubauer, 1995) are crucial in the response to fluctuating light (Kono et al., 2014). These alternative electron flows act as electron sinks thereby protecting plants from photoinhibition. Far-red light increased the photoprotection of PSI against fluctuating light possibly due to the beneficial effects of far-red light on photosynthesis thereby accelerating NPQ relaxation and PSII yield (Kono, Yamori, Suzuki, & Terashima, 2017). In a recent study, a FLUCTUATING LIGHT ACCLIMATION PROTEIN1 (FLAP1) was identified controlling NPQ formation during fluctuating light (Sato et al., 2017).

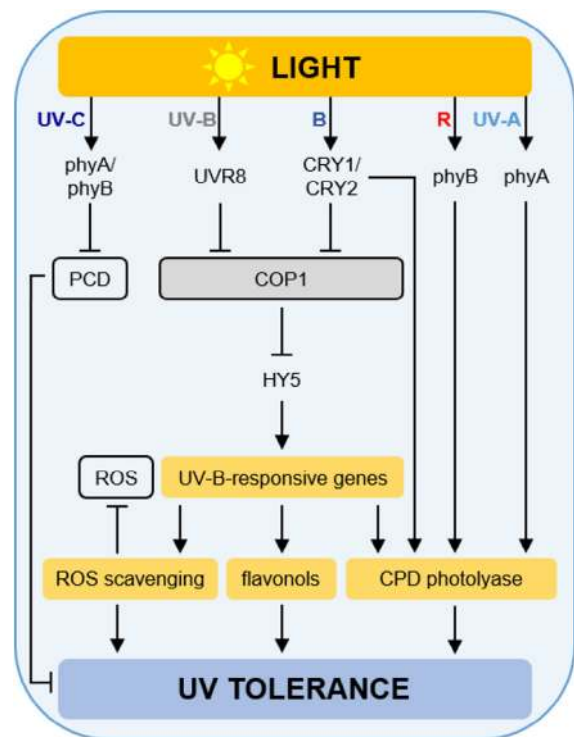

**FIGURE 5** Signalling pathways involved in the crosstalk between light and the response to UV stress. To overcome UV stress, plants induce UV-B-responsive genes, including genes encoding ROS scavenging enzymes, flavonol biosynthesis enzymes and cyclobutene pyrimidine dimers (CPD) photolyases. The UV-B-responsive genes are regulated via UVR8 and CRY1 in a COP1/HY5-dependent manner. The CPD photolyases can also be induced through phyB and phyA. UV-C irradiance, perceived by phyA or phyB, results in an inhibition of programmed cell death (PCD). For more detailed information about the different pathways, please refer to Section 2.4. Abbreviations: B, blue light; R, red light; UV, ultraviolet light [Colour figure can be viewed at [wileyonlinelibrary.com](http://wileyonlinelibrary.com)]

Long-term adjustments in response to fluctuating light have been recently studied in genome-wide transcriptome profile analysis in *Ara-bidopsis* pointing to a global reprogramming of gene expression (Schneider et al., 2019). Especially genes related to photoprotection, photosynthesis, photorespiration, pigments, prenylquinone and vitamin metabolism were differently expressed. Moreover, fluctuating light acclimation interacts with leaf developmental stage and the time of the day pointing to a possible role for the circadian clock. The authors hypothesized that blue light might positively affects fluctuating light acclimation (Schneider et al., 2019).

## 2.3 | Photoperiod stress

Changes of the photoperiod, in particular a prolongation of the light period, induce photoperiod stress (originally circadian stress) (Nitschke et al., 2016; Nitschke, Cortleven, & Schmülling, 2017) (Figure 4). Amongst others, the stress phenotype is characterized by the induction of stress marker genes such as ZAT12 and BAP1 and

increased oxidative stress during the night following an extended light period. The next day, a significant reduction of PSII maximum quantum efficiency (Fv/Fm) and eventually programmed cell death in the leaves ensues. Photoperiod stress induces an oxidative burst-like response and is associated with increased apoplastic peroxidase and decreased catalase activities (Abuelsoud, Cortleven, & Schmölling, 2020). *Arabidopsis* mutants with a reduced cytokinin content or signalling are more sensitive to the stress than wild-type plants indicating a protective function of the hormone, especially of the root-derived *trans*-zeatin forms (Frank, Cortleven, Novak, & Schmölling, 2020; Nitschke et al., 2016). In addition certain mutants of the circadian clock showed a strong stress response which have a lowered expression or impaired function of two key regulators of the circadian clock – CIRCADIAN CLOCK ASSOCIATED1 (CCA1) and LATE ELONGATED HYPOCOTYL (LHY) – in common (Nitschke et al., 2016). This indicated that a functional clock is essential to cope with photoperiod stress. Interestingly, recurrent photoperiod stress events reduce the stress response to subsequent stresses suggesting that it is memorized by plants (V.M.R., Sylvia Illgen, T.S. and A.C., unpublished result).

Which part of the light signalling pathway or which light quality has an impact on the strength of the photoperiod stress response is yet not known. This and the natural conditions under which photoperiod stress occurs are presently being explored.

## 2.4 | Stress by ultraviolet light

UV light is part of the solar spectrum and can be divided into three wavebands: UV-C (200–280 nm), UV-B (280–315 nm) and UV-A (315–400 nm). While low doses of UV-B radiation are known to cause non-harmful “eustress,” extreme irradiance causes “distress” and can result in programmed cell death (Hideg et al., 2013) (Figure 5). UV light is especially harmful to PSII (Ohnishi et al., 2005; Takahashi et al., 2010) but also causes photodamage to DNA, production of ROS and a change in cellular processes like photomorphogenic or wound responses (Müller-Xing, Xing, & Goodrich, 2014).

DNA damage by UV light includes double strand breaks and the formation of covalent bonds between adjacent pyrimidines, the so-called cyclobutene pyrimidine dimers (CPDs) which results in inhibition of transcription and replication (Britt, 2002). Light-dependent CPD photolyases repair these dimers restoring the native DNA form (Britt, 2002). The expression of CPD photolyase genes is controlled by red light in a phyB-dependent, by UV-A in a phyA-dependent, by UV-B in an UVR8-dependent, and by blue light in a CRY-dependent manner (Li et al., 2015) (Figure 5). The UVR8-COP1-HY5 pathway is the main signalling cascade involved in UV tolerance. CRYs and UVR8 interact to regulate plant growth under UV light (Rai et al., 2019). Recently, it was shown that cryptochromes, especially CRY1, modulate the UVR8 photoreceptor activity contributing to increased UV tolerance (Tissot & Ulm, 2020). In addition to their role in CPD photolyase gene expression, phyA and phyB act as protectors of UV-C-triggered cell death in *Arabidopsis* (Rusaczonok et al., 2015). To cope

with UV damage, plants accumulate UV-protective compounds such as phenolics in the vacuoles of the leaf epidermis (Emiliani, Grotewold, Falcone Ferreyra, & Casati, 2013). Among them are phenolic acids, anthocyanins and flavonols. The flavonoid biosynthesis pathway is regulated by the production of flavonol glycosides family of transcription factors which are induced by UV-B in an UVR8- and HY5-dependent manner (Brown & Jenkins, 2008; Davey et al., 2012; Favory et al., 2009). Furthermore, UV irradiance triggers the expression of genes involved in protection against oxidative stress to reduce the ROS produced during UV stress. Similarly, transcription factors and proteases, which play key roles in UV tolerance, are induced by UV light (Brown et al., 2005; Müller-Xing et al., 2014) (Figure 5).

## 3 | LIGHT AND TEMPERATURE STRESS

Abrupt drops or boosts of temperature impose dramatic effects on plant survival. The lowest temperature often coincides with the night while midday is often the warmest moment of the day. It is therefore not unexpected that temperature responses are closely linked with light signals. Light signals reset the circadian clock but also provide plants with information concerning, for example, seasonal changes or day length, which enables them to anticipate future temperature conditions (Figures 6 and 7).

### 3.1 | Light and cold acclimation

Low temperatures slow down metabolic processes in plants and adversely affect growth (Figure 6). Some plants are able to increase their tolerance after longer exposure to low non-freezing temperatures, a process called cold acclimation (Guy, Kaplan, Kopka, Selbig, & Hinch, 2008; Levitt, 1980; Thomashow, 1999). The changes occurring in response to low temperatures resulting in increased freezing tolerance include transcriptional and posttranscriptional changes that can be abscisic acid (ABA)-dependent or -independent. The best understood cold regulatory pathway in *Arabidopsis* is the C-repeat/dehydration-responsive element - binding factor (CBF/DREB) signalling cascade. The CBF regulon consists of the stimulation of the central regulatory genes, *CBF1* to *CBF3*, after cold temperatures resulting in the induction of cold-regulated (*COR*) genes (Pareek, Khurana, Sharma, & Kumar, 2017; Thomashow, 2010). The induction of CBF genes is under control of *CCA1* and *LHY*, the central regulators of the circadian clock, with a peak around ZT (zeitgeber) 4 – 8 and a trough at ZT16 (Dong, Farre, & Thomashow, 2011; Fowler, Cook, & Thomashow, 2005). A direct link between the clock and the cold responses forms *PIF7* whose activity is regulated by *TOC1 (TIMING OF CAB EXPRESSION 1)* acting together with phyB as a transcriptional repressor of *CBF2* (Kidokoro et al., 2009). Besides this circadian regulation of cold acclimation, light and photoperiod are also crucial (Maibam et al., 2013).

Light is required for the induction of several genes involved in cold acclimation, including the CBFs (Kim, Kim, Park, & Kim, 2002;

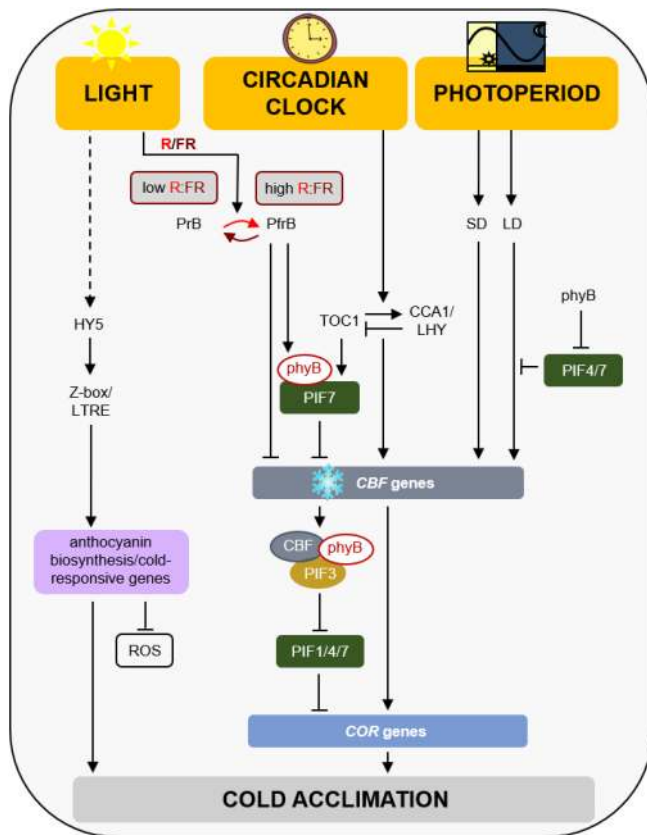

**FIGURE 6** Crosstalk between light and cold acclimation signalling pathways. Upon cold temperatures (indicated by the ice crystal), the circadian clock-regulated *CBF* genes are induced resulting in cold acclimation. Upon light perception, HY5 is activated which induces the expression of anthocyanin biosynthesis and cold-responsive genes through the Z-box/LTRE thereby also reducing ROS. Changes in light quality (R:FR) are sensed by phyB which exists in an active PfrB and an inactive PrB form. Under high R:FR, PfrB represses *CBF* gene expression, while low R:FR caused by, for example, increased twilight during autumn results in cold acclimation by decreasing the amount of active PfrB. PIF7 which represses *CBF* gene expression is under control of TOC1, a central component of the circadian clock, and under the control of phyB. Under short day conditions (SD), *CBF* genes are strongly induced causing cold acclimation. Under warmer long day conditions (LD), *PIF4* and *PIF7* which are under the control of phyB are higher expressed resulting in an inhibition of *CBF* gene expression. As days shorten, for example, during autumn, this repression falls away resulting in cold acclimation. *CBF* proteins interact with phyB and PIF3 causing degradation of PIF1, PIF4 and PIF5 which releases *COR* genes from PIF repression. For more information concerning the different pathways, please refer to Section 3.1. Abbreviations: R, red light; FR, far-red light; LTRE, low temperature responsive element [Colour figure can be viewed at [wileyonlinelibrary.com](http://wileyonlinelibrary.com)]

Soitamo, Piippo, Allahverdiyeva, Battchikova, & Aro, 2008) (Figure 6). Light signalling mediated through phyB is important for cold-induced gene expression in *Arabidopsis* (Kim et al., 2002), rice (He et al., 2016) and tomato (Wang et al., 2016). Recently, it was shown that phyB positively regulates freezing tolerance by direct interaction with CBFs (Jiang et al., 2020) which additionally interact with PIF3 (Jiang

et al., 2017). The CBF-PIF3-phyB complex prevents PIF3 and phyB from undergoing light-dependent degradation. The cold-stabilized phyB promotes the degradation of PIF1, PIF4 and PIF5 resulting in the expression of the *COR* genes, thus increasing freezing tolerance in *Arabidopsis* (Jiang et al., 2020). In tomato, it was reported that phyA and phyB function antagonistically to regulate cold acclimation. Far-red light-induced activation of phyA leads to the induction of ABA signalling and subsequent jasmonate signalling causing an activation of the CBF pathway resulting in cold acclimation (Wang et al., 2016). A similar influence of light quality was shown in *Arabidopsis*. Low red to far-red ratio (R:FR) increases *CBF* gene expression in a circadian-regulated but ABA-independent manner thereby enabling plants to confer freezing tolerance at higher temperatures than those required for cold acclimation (Franklin & Whitelam, 2007a). Using this regulatory mechanism, the reduced ambient temperature, shorter days and increased twilight (during which the R:FR ratio is lower) during autumn might initiate a certain degree of cold acclimation before the onset of winter (Franklin & Whitelam, 2007a). A comparable effect of a lower R:FR ratio on frost tolerance was also found in barley (Ahres, Gierczik, Boldizsár, Vítámvás, & Galiba, 2020).

In addition, the photoperiod can regulate the *CBF* regulon (Figure 6). Lee and Thomashow (2012) showed that short day-grown plants are more freezing tolerant than long day-grown plants. Under long day conditions, the *CBF* regulon is repressed by phyB, PIF4 and PIF7 causing a reduction of freezing tolerance. This repression is relieved by shortening of the daylength causing an increased expression of the *CBF* genes preparing plants for upcoming colder temperatures. In addition, geographical distant accessions of *Arabidopsis* exhibit differences in freezing tolerance which can be related to the photoperiod conditions they are geographically associated to (Alonso-Blanco et al., 2005).

Another key regulator of cold and light is HY5, a bZIP transcription factor, which has a prominent role in light signalling (Lau & Deng, 2010) (Figure 6). In response to low temperatures, HY5 is responsible for the induction of ca. 10% of all cold-inducible genes in *Arabidopsis* through the Z-box containing a low-temperature-responsive element. Among the HY5-inducible genes are those involved in anthocyanin biosynthesis protecting plants from high ROS accumulation (Harvaux & Kloppstech, 2001). HY5 levels are also transcriptionally regulated by low temperature via a CBF- and ABA-independent pathway and posttranslationally via nuclear exclusion of COP1 (Catalá, Medina, & Salinas, 2011).

Together, these studies clearly point to a complex crosstalk between light and the response to cold temperatures. Light provides information concerning daily or seasonal changes to plants – be it light quality or quantity – enabling them to get prepared for colder temperatures by adapting the cold acclimation response but also by decreasing ROS levels (Figure 6).

### 3.2 | Light and thermotolerance

High temperatures damage cellular components (Larkindale & Knight, 2002; Pospisil, 2016), affect membrane fluidity and

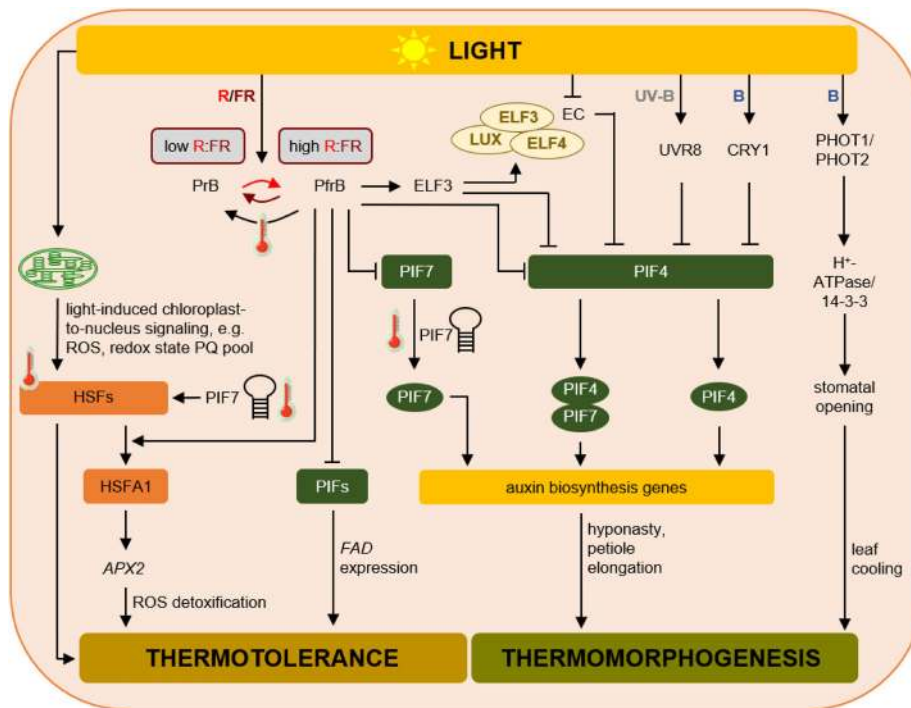

**FIGURE 7** Crosstalk between the light signalling pathway and the signalling pathways involved in thermotolerance and thermomorphogenesis. High temperature causes the induction of heat shock transcription factors (HSFs) which establish thermotolerance. Under the influence of light, a chloroplast-to-nucleus signal contributes to the induction of HSFs. Independent of this chloroplast signal, the increase in HSA1 upon heat stress causes a phyB-dependent increase in APX2 expression resulting in ROS detoxification. Under shade conditions, phyB-dependent repression of PIFs is lost thereby affecting FAD expression and fatty acid desaturation causing increased thermotolerance. In thermomorphogenesis, different photoreceptors are involved. Especially phyB, which is a thermosensor, and PIF4/PIF7 play a central role. Thermal reversion and low R:FR ratios result in an inactivation of phyB, thereby resolving its inhibitory effect on PIF7 and PIF4. As a consequence, PIF7 protein levels accumulate under higher temperatures due to increased translation which is additionally enhanced by an RNA hairpin within its 5' untranslated region resulting in increased auxin biosynthesis. This PIF7 RNA hairpin also improves the translation of heat shock transcription factors thereby increasing thermotolerance. Just like PIF7, PIF4 stimulates the expression of auxin biosynthesis genes to regulate morphological adaptations like hyponasty or petiole elongation as part of thermomorphogenesis. PIF4 is additionally inhibited by UVR8 and CRY1 as well. phyB also influences ELF3 abundance which blocks PIF4 activity in an evening clock (EC)-independent and -dependent pathway involving also LUX and ELF4, other components of the EC. Blue light perceived by phototropins results in stomatal opening and increased leaf cooling. For more information concerning the different pathways, please refer to Sections 3.2 and 3.3. The thermometer indicates processes which are induced/improved by increased ambient temperatures. Abbreviations: R, red light; FR, far-red light; B, blue light; UV, ultraviolet light; TFs, transcription factors; HSA1, HEAT SHOCK FACTOR PROTEIN A1, FAD, FATTY ACID DESATURASE [Colour figure can be viewed at [wileyonlinelibrary.com](http://wileyonlinelibrary.com)]

permeability (Sangwan, Orvar, Beyerly, Hirt, & Dhindsa, 2002), alter enzyme activity resulting in metabolic imbalances (Kampinga, Brunsting, Stege, Burgman, & Konings, 1995), and negatively influence photosynthesis by impairing PSII electron transport and the D1 repair cycle (Balfagon et al., 2019; Murata, Takahashi, Nishiyama, & Allakhverdiev, 2007; Pospisil, 2016). Plants cope with normally lethal high temperatures after being exposed to lower non-lethal high temperatures in a process called thermotolerance (Larkindale, Hall, Knight, & Vierling, 2005; Larkindale & Vierling, 2008; Song, Jiang, Zhao, & Hou, 2012). Essential during thermotolerance is the induction of heat shock factors (HSFs) activating the expression of protective chaperones, such as HEAT SHOCK PROTEIN70 (HSP70), preventing protein denaturation (Mittler, Finka, & Goloubinoff, 2012).

In *Arabidopsis*, thermotolerance varies diurnally reaching a peak at noon and a trough at dawn (Han, Park, & Park, 2019a). This regulation

is correlated with the higher expression of HSPs during the light period (Dickinson et al., 2018). Light gates the magnitude of the response to high temperature, with the expression of HSPs being much higher after a temperature shift. This light priming effect on thermotolerance is caused by light-induced chloroplast-to-nucleus signalling components such as ROS or the redox state of the plastoquinone (PQ) pool (Figure 7). A similar light priming effect, independent of the above-mentioned one, was also observed by Han et al. (2019a). They found that light primes the HEAT SHOCK FACTOR A1 (HSA1)-mediated thermal induction of ASCORBATE PEROXIDASE2 (APX2) gene expression under high temperatures in a phyB-dependent, but PIF-independent manner, resulting in ROS detoxification necessary for the induction of thermotolerance (Han et al., 2019a; Han, Park, & Park, 2019b). phyB also acts as a molecular switch to turn on/off several heat stress response genes under different light conditions



resulting in thermotolerance (Song, Liu, Hu, & Wu, 2017). Low red to far-red ratios (R:FR) reduce the activity of phyB, thereby increasing the abundance of PIFs resulting in a higher tolerance to heat (Arico et al., 2019). In addition, these shade conditions decrease the transcript levels of *FATTY ACID DESATURASES*(FADs) resulting in a shift in fatty acid composition towards more saturated fatty acids. During heat stress, the produced ROS promote peroxidation of unsaturated fatty acids (Anjum, Khan, Sofo, Baier, & Kizek, 2016). By reducing the targets of oxidative damage, thermotolerance increases (Arico et al., 2019). An overview of the crosstalk between light and thermotolerance is given in Figure 7.

### 3.3 | Light and thermomorphogenesis

Thermomorphogenesis is induced by mild temperature elevation below the heat stress range and involves morphological changes such as a faster flowering, hypocotyl and petiole elongation and a reduction of the stomatal index and leaf hyponasty (Quint et al., 2016; Casal & Balasubramanian, ). During thermomorphogenesis, phyB was found to function as a thermosensor and at warmer temperatures, the far-red light-activated reversion of Pfr is accelerated (Jung et al., 2016; Legris et al., 2016).

Downstream of phyB, the PIFs, especially PIF4 and PIF7, are key transcriptional regulators promoting plant responses to elevated temperatures (Figure 7). At higher temperatures, the inhibitory function of phyB on PIF4 is lost due to the acceleration of the far-red light-activated reversion of Pfr (Jung et al., 2016; Legris et al., 2016). This results in a stabilization of PIF4 causing the induction of auxin-responsive genes such as *INDOLE ACETIC ACID-INDUCIBLE19* (*IAA19*) resulting in morphological changes including leaf hyponasty and petiole elongation (Jung et al., 2016; Koini et al., 2009). Likewise, *CRY1* and *UVR8* repress high temperature-induced plant responses through respectively, direct physical interaction with PIF4 thereby reducing its transcription (Ma et al., 2016) or by inhibiting PIF4 via a COP1-dependent manner (Hayes et al., 2017; Yin, 2017). Independent of the *CRY1*-PIF4 regulon, blue light perceived by phototropins activates  $H^+$ -ATPases and 14-3-3 proteins which results in stomatal opening causing leaf cooling and so improves thermotolerance (Kostaki et al., 2020).

PIF4 is also transcriptionally and posttranscriptionally regulated by ELF3 via two separate pathways (Figure 7). In light, phyB promotes ELF3 accumulation which binds to PIF4 in an evening complex-independent manner thus reducing PIF4 activity (Nieto, Lopez-Salmeron, Daviere, & Prat, 2015). Under high temperatures, *BBX18* and *BBX23* interact with ELF3 and negatively control ELF3 protein accumulation resulting in a release of the ELF3-mediated repression of PIF4 causing a thermomorphogenesis response (Ding et al., 2018). Together with ELF4 and LUX, ELF3 forms an evening complex and this repressive complex binds to the *PIF4* promoter early during the night (Nieto et al., 2015). This action of the evening complex is temperature-dependent suggesting that it might also act as a thermosensor (Ezer et al., 2017). Recently, ELF4 was identified as a key

modulator of the thermosensitive evening complex activity (Silva et al., 2020).

In addition to PIF4, also PIF7 is a central player of thermomorphogenesis (Figure 7). Both transcription factors are similarly important to promote auxin responsiveness and depend on each other possibly by forming heterodimers (Fiorucci et al., 2019). Recently, it was shown that PIF7 is necessary for thermomorphogenesis under cycling temperatures in long day conditions and controls the expression of the auxin biosynthesis gene *YUCCA8* (Chung et al., 2020). Furthermore, the translation of *PIF7* mRNA is enhanced under warmer temperatures by the formation of an RNA hairpin within its 5' untranslated region resulting in increased protein synthesis. This RNA thermoswitch was also found to control the translation of *HSFA2* which is important during thermotolerance (Chung et al., 2020). An overview of the crosstalk between light and thermomorphogenesis is given in Figure 7.

## 4 | LIGHT AND DROUGHT STRESS

Drought resistance is an important trait to overcome detrimental effects on plant performance and productivity. Drought activates specific signalling pathways resulting in physiological and developmental adaptations to optimize water use (Fahad et al., 2017; Nakashima, Yamaguchi-Shinozaki, & Shinozaki, 2014). The plant hormone abscisic acid (ABA) is essential for the response to drought stress, but both ABA-dependent and -independent signalling cascades are involved in the transcriptional regulation of target genes to increase the plant's resistance to drought stress (Joshi et al., 2016; Kim et al., 2012; Mahmood et al., 2019).

Upon drought, the plant stomata close to reduce water loss via transpiration upon perception of ABA, whose biosynthesis is promoted under drought stress (Daszkowska-Golec & Szarejko, 2013; Outlaw, 2003). Besides ABA, stomatal opening is also diurnally regulated and influenced by temperature (Tallman, 2004) and light (Matthews, Violet-Chabrand, & Lawson, 2020). Stomatal aperture is driven by two distinct pathways: the "red" or photosynthetic response and the guard cell-specific "blue" response involving phototropins. *CRY1* has been shown to work additively to the phototropins in a COP1-dependent way to regulate stomatal opening in response to blue light (Mao, Zhang, Sang, Li, & Yang, 2005) (Figure 8). In response to red light, phyB mediates stomatal opening in a COP1- or PIF3/PIF4-dependent way (Wang, Lian, Kang, & Yang, 2010). Although the regulation of stomatal opening is essential for the drought stress response and is strongly influenced by light, only few studies have described a mechanism connecting light and light signalling components to drought tolerance (Figure 8). Overexpression of *DEHYDRATION-RESPONSIVE ELEMENT BINDING 1A* (*DREB1A*) and *OsPIL1*, a rice homologue of PIF4, in *Arabidopsis* resulted in increased drought tolerance by the activation of cell wall-regulated genes (Kudo et al., 2017). While *Arabidopsis cry1 cry2* mutants are more drought-tolerant than wild type, *CRY1*-overexpression plants show excessive water loss which is associated with the repressor function of COP1 on stomatal opening (Mao

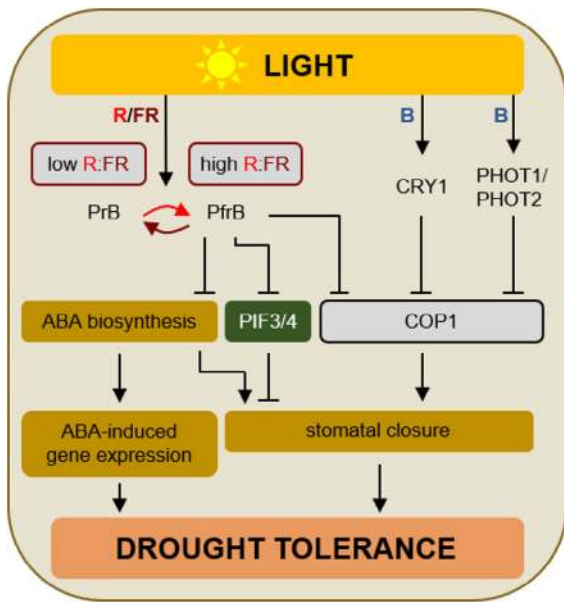

**FIGURE 8** Signalling pathways involved in the crosstalk between light and the response to drought stress. Drought stress results in biosynthesis of abscisic acid (ABA) leading to ABA-dependent gene regulation causing drought tolerance. In addition, stomata close preventing water loss via transpiration. Under shade conditions (low R:FR), ABA biosynthesis is stimulated which results in the induction of ABA-induced gene expression causing drought tolerance. In addition, low R:FR increases the sensitivity to ABA resulting in improved drought tolerance. Besides, phyB regulates stomatal opening in a COP1- or PIF3/PIF4-dependent way. Blue light perceived by CRY1 and PHOT1/PHOT2 represses the inhibitory function of COP1 on stomatal opening resulting in closed stomata thereby increasing drought tolerance. For more information concerning the different pathways, please refer to Section 4. Abbreviations: R, red light; FR, far-red light; B, blue light [Colour figure can be viewed at [wileyonlinelibrary.com](http://wileyonlinelibrary.com)]

et al., 2005). Gonzalez, Ibarra, Piccoli, Botto, and Boccalandro (2012) revealed that transcription levels of ABA-induced genes are strongly reduced in *phyB* mutants after ABA treatment and that *phyB* mutants wilt earlier than wild type due to the maintenance of open stomata. It was concluded that *phyB* increases drought tolerance in *Arabidopsis* by enhancing ABA sensitivity. Previously, it was already shown that *phyB* increases stomatal density, the stomatal index and influences the presence of stomata on both sides of the leaf in high red to far-red ratios (Boccalandro et al., 2009). This would imply that under these conditions, plants have a higher water usage; however, in response to drought, stomata are rapidly closed through an increased sensitivity to ABA (Gonzalez et al., 2012). Under shade conditions, the survival of Ghanaian trees is higher than in high light suggesting that shade enhances plant performance under drought stress conditions (Amisshah, Mohren, Kyereh, & Poorter, 2015). The activity of osmoprotectants and antioxidants was also increased under shade conditions suggesting that pre-treatment with shade might help to overcome the drastic effects of drought in soybeans in dense cropping systems (Asghar et al., 2020).

## 5 | LIGHT AND BIOTIC STRESS

Plants are also exposed to numerous biotic environmental factors such as pathogens or herbivores, affecting their performance. The responses to these biotic stresses are influenced by light (Ballaré, 2014). In particular, shade conditions have a strong influence on plant responses to pathogen and herbivore attacks (Ballaré, 2014; Fernandez-Milmanda et al., 2020). In the following sections, we will discuss in more detail the role of light in plant responses to pathogen and herbivore attack, and to neighbouring plants. An overview of the mechanisms involved is shown in Figure 9.

### 5.1 | Light and pathogen attack

Plants possess a multi-layered immune system that enables them to recognize pathogen attacks and subsequently initiate defence responses (reviewed in De Wit, 2007). After breaking through the plant's cell wall, pathogens are confronted with an active plant immunity, consisting of the primary innate immunity and a host-specific, secondary innate immune response (for review, see Chisholm, Coaker, Day, & Staskawicz, 2006; Delprato, Krapp, & Carrillo, 2015; Jones & Dangl, 2006). During the primary innate immune response, pathogen-associated molecular patterns (PAMPs) are detected by pattern recognition receptors resulting in PAMP-triggered immunity which includes the activation of several defence responses such as induction of pathogen-responsive genes, ROS production or alterations in hormone signalling pathways involving salicylic acid and jasmonic acid. In order to inhibit innate plant immunity, certain pathogens produce effector proteins that are encoded by avirulence genes (De Wit, 1997, 2007; Shamrai, 2014). The secondary immune response enables plants to recognize and counteract the pathogen-derived effectors through resistance proteins encoded by *R* genes (De Wit, 2007) which results in effector-triggered immunity in the affected plants (Jones & Dangl, 2006). PAMP- and effector-triggered immunity lead to equal plant responses and have similar signalling pathways but these are differently used (for review, see Tsuda & Katagiri, 2010). During effector-triggered immunity, programmed cell death is considered as a component of the hypersensitive response of plants (Chisholm et al., 2006) which is affected by intracellular ROS (Torres, 2010). ROS contribute to the establishment of systemic acquired resistance that ensures defence in distant plant parts following effector-triggered immunity (Karpinski, Gabrys, Mateo, Karpinska, & Mullineaux, 2003; Zhang et al., 2018).

Light is crucial for activating full resistance responses in plant-pathogen interactions (Ballaré, 2014; Delprato et al., 2015; Roberts & Paul, 2006; Roden & Ingle, 2009; Trotta, Rahikainen, Konert, Finazzi, & Kangasjärvi, 2014) (Figure 9). Already in 1970, researchers showed that the hypersensitive response is dependent on light (Lozano and Sequira, 1970). For instance, light affects local defence responses such as the accumulation of salicylic acid (SA), salicylic acid glucoside, but also SA-responsive PATHOGENESIS-RELATED PROTEIN1 1 (PR1). Light can induce key genes of the phenylpropanoid pathway in *Arabidopsis* after

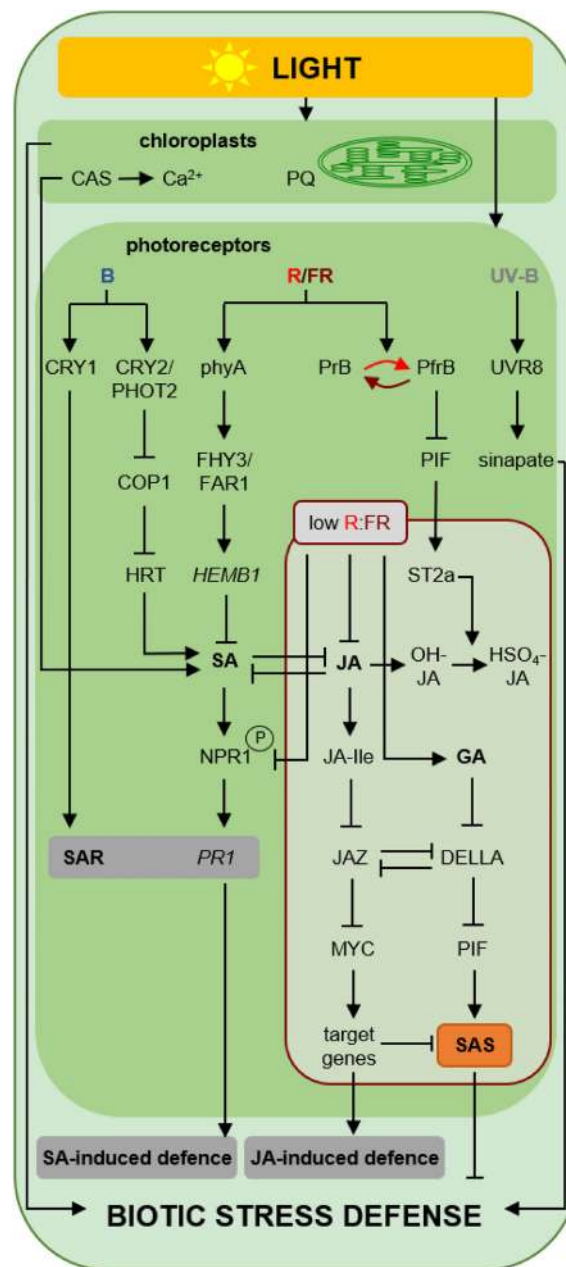

**FIGURE 9** Signalling pathways involved in the crosstalk between light and biotic stress defence. Plant responses to pathogen or herbivore attack are affected by light. During biotic stress defence, plants perceive and mediate light signals via chloroplasts or photoreceptors. The chloroplast redox status, especially the redox status of the plastoquinone (PQ) pool, influences the plant defence to pathogens. The functionality of chloroplasts plays an important role in mediating the plant hypersensitive response. The chloroplast-located calcium-sensing receptor CAS mediates calcium signals affecting biotic stress defence. In addition, CAS controls the accumulation of salicylic acid (SA). In *Arabidopsis* plants, SA levels are regulated by blue light via a CRY2/PHOT2-mediated and by red light via phytochrome-regulated pathways. CRY2 and PHOT2 negatively regulate COP1 which in turn regulates the stability of the R protein HRT (Hypersensitive Response to Turnip Crinkle Virus), thereby influencing pathogen resistance. The homologous, phytochrome-regulated TFs FHY3 and FAR1 influence SA-induced defence by controlling *HEMB1* expression. The plant SA content influences the protein kinase NPR1 which regulates the transcription of SA-induced defence genes, such as *PR1*, representing a marker for systemic acquired resistance (SAR). CRY1 promotes *PR1* gene expression. During shade (low R:FR), phosphorylation of NPR1 is inhibited which affects SA-induced defence. Shade environments attenuate jasmonic acid (JA)-induced defence. The *Arabidopsis* sulphotransferase ST2a which is regulated by PIFs and responsible for the formation of  $\text{HSO}_4\text{-JA}$ , thereby decreasing levels of active JA, is upregulated under FR light conditions. The stability of JAZ proteins is enhanced during low R:FR in a phyB-dependent manner leading to attenuated defences. In addition, gibberellin (GA) activity is enhanced during shade resulting in decreased DELLA protein functionality. DELLAs are negative regulators of the shade avoidance syndrome (SAS) and are involved in preventing interaction of JAZ proteins with its targets. UV-B light perceived by the UVR8 receptor enhances sinapate production involved in biotic stress defence. For more information concerning the different pathways, please refer to Section 5. Abbreviations: R, red light; FR, far-red light; B, blue light; UV, ultraviolet light; TFs, transcription factors [Colour figure can be viewed at [wileyonlinelibrary.com](http://wileyonlinelibrary.com)]

inoculation with avirulent *Pseudomonas syringae* pv. *maculicola* bacteria (*Psm*) (Zeier, Pink, Mueller, & Berger, 2004). Systemic acquired resistance in response to the avirulent bacteria was completely lost when the primary infection process occurred in the absence of light. Not only SA biosynthesis, but also SA perception is influenced by light perceived by *phyA* and *phyB* (Genoud, Buchala, Chua, & Metraux, 2002). Chandra-Shekara et al. (2006) demonstrated that exposure to prolonged darkness prior to inoculation with the Turnip Crinkle Virus compromised the development of the hypersensitive response and that the virus can spread systemically. The absence of light, however, does not influence the Turnip Crinkle Virus-induced elevation of the SA levels resulting in systemic acquired resistance signalling to enhance resistance to future pathogen attacks and a hypersensitive response (Conrath, 2006). These results indicate that light or a light-derived signal is required together with the SA-dependent pathway to positively modulate the early resistance to Turnip Crinkle Virus.

Plant immune responses to pathogen attacks are also affected by the length of the light period. SA, PR1 accumulation and the magnitude of the hypersensitive response correlated with the length of the light period and depended not on the circadian clock in *Arabidopsis* plants inoculated with the avirulent bacterium *Psm* ES4326 *avrRpm1* (Griebel & Zeier, 2008). However, the involvement of circadian-regulated stomata closure in the defence was not considered by the inoculation method (Roden & Ingle, 2009). A comparable effect was also described in *Arabidopsis* plants (ecotype *Ler-0*) infected with Cauliflower Mosaic Virus. Disease symptoms were stronger in short day-grown plants than in plants grown under long day conditions, although the virus replication was even higher in long day-grown *Arabidopsis* (Cecchini et al., 2002). On the transcriptional level, the interaction of the *Arabidopsis* hexameric promoter element FORC<sup>A</sup> with its targets is influenced by the length of the light period (Evrard et al., 2009). *Arabidopsis* FORC<sup>A</sup> is especially conserved in the promoters of genes regulated by both pathogens and light, thereby connecting light signalling and pathogen resistance (Evrard et al., 2009; Roden & Ingle, 2009).

Light intensity also affects plant pathogen resistance (Roden & Ingle, 2009). *Arabidopsis* plants are less susceptible to the virulent *Pseudomonas* bacteria, when plants were subjected prior to infection to a high light treatment (Mühlenbock et al., 2008). The improved resistance in acclimated plants was observed in both leaves treated with excess light and distant ones. This indicates that excess excitation energy promotes local resistance and systemic acquired resistance to virulent pathogens in *Arabidopsis* (Mühlenbock et al., 2008). The authors also showed that excess excitation energy stimulates several genes necessary for resistance to pathogens in addition to their importance in light acclimation (Mühlenbock et al., 2008).

During biotic stress defence, light signals are mediated through photoreceptors or chloroplasts (Ballaré, 2014; Delprato et al., 2015; Roden & Ingle, 2009). Especially plant phytochromes and red light have been connected to light-dependent defence responses (Figure 9). Nightly red light treatment significantly enhanced the resistance of tomato plants against *Pseudomonas syringae* pv. *tomato* (*Pst*) DC3000. This effect correlated with increased SA accumulation and defence-related gene transcription indicating that SA-mediated

signalling pathways are involved in red light-induced resistance to pathogens (Yang et al., 2015). Two homologous transcription factors essential for *phyA* signalling, FAR-RED ELONGATED3 (FHY3) and FAR-RED IMPAIRED RESPONSE1 (FAR1), negatively impact signalling and plant immunity by promoting *HEMB1* expression essential for chlorophyll biosynthesis and plant growth (Wang et al., 2016). *Arabidopsis phyA* and *phyB* mutants are more susceptible to *Pst* DC3000 *avrRpt2* in light which might be connected to a reduced SA perception causing a decreased expression of *PR1* (Genoud et al., 2002). In contrast, the pathogen resistance in Turnip Crinkle Virus-infected *Arabidopsis* Dijon-17 plants is independent of *phyA* or *phyB* (Chandra-Shekara et al., 2006). Similarly, Griebel and Zeier (2008) showed that the hypersensitive response in *Arabidopsis phyA* and *phyB* mutants following *Psm* ES4326 *avrRpm1* inoculation was similar to the response observed in wild-type *Arabidopsis* plants suggesting no functional role for phytochromes in plant effector-triggered immunity. However, phytochromes are necessary for systemic acquired resistance, as *phyA phyB* double mutants did not improve their resistance in systemic leaves following a first infection with virulent *Psm* ES4326 bacteria. Together these studies indicate that phytochromes mediate plant resistance to pathogen attacks, but this might be dependent on the specific plant response to the pathogen and the pathogen itself. Several studies suggested that systemic acquired resistance is independent of cryptochromes or phototropins (Delprato et al., 2015; Griebel & Zeier, 2008). In contrast, Wu and Yang (2010) showed that *CRY1* enhances plant resistance in response to *Pst* DC3000 *avrRpt2* in both local and systemic leaves. They also revealed that *PR1* expression decreased in *cry1* mutants under continuous light following SA treatment, while an increase was observed in *CRY1*-overexpressing plants under the same conditions. Although the hypersensitive response occurs independently of *CRY1*, the authors concluded that *CRY1* positively regulates R protein-mediated resistance to *Pst* DC3000 in incompatible plant-pathogen interactions. Moreover, *CRY2* and *PHOT2* are, via a COP1-dependent signalling pathway, required for the stability of an R protein-providing resistance to Turnip Crinkle Virus (Jeong et al., 2010; Jeong, Kachroo, & Kachroo, 2010). Besides blue and red light, also UV-B enhances plant resistance to pathogen attacks. It activates SA-associated defence mechanisms in a jasmonate-deficient *Arabidopsis* mutant (Escobar-Bravo et al., 2019) and enhances sinapate production in an UVR8-dependent manner upon infection with the fungus *Botrytis cinerea* (Demkura & Ballaré, 2012). An overview of the signalling pathways involved in the crosstalk between light and biotic stress defence can be found in Figure 9.

In addition to photoreceptors also chloroplasts are crucial for pathogen defence responses (for reviews see Kangasjärvi, Neukermans, Li, Aro, and Noctor (2012), Trotta et al. (2014), Serrano, Audran, and Rivas (2016) and Delprato et al. (2015)) (Figure 9). Genoud et al. (2002) showed that chloroplasts are important for the hypersensitive response during incompatible plant-pathogen interactions. However, the expression of *PR* genes does not require chloroplasts, and SA-induced defence responses do not rely on chloroplast-mediated production of carbohydrates. The chloroplast redox status, in particular alterations in the redox

status of the plastoquinone (PQ) pool, impacts both, acclimation to excess light as well as pathogen resistance (Mühlenbock et al., 2008; Roden & Ingle, 2009). The calcium-sensing receptor CAS which is located in chloroplast thylakoid membranes and mediates stromal calcium signals is required for PAMP-triggered immunity as well as R gene-regulated effector-triggered immunity. CAS not only controls SA accumulation but also mediates defence gene expression in response to PAMPs (Nomura et al., 2012). Chloroplasts themselves can also be target of pathogen-derived effector proteins (Kangasjärvi et al., 2012). For instance, the bacterial effector HopI1 secreted by *P. syringae* pathogens remodels chloroplast thylakoid structures and inhibits SA increase (Jelenska et al., 2007). The cysteine protease HopN1 representing another effector of *Pseudomonas* bacteria inhibits ROS production in chloroplasts and negatively affects PSII activity (Rodriguez-Herva et al., 2012).

## 5.2 | Light and insect herbivory

As insects feed, they damage plants. Insect herbivores can be detected by plants through the perception of damage-associated molecular patterns (DAMPs) or herbivore-associated molecular patterns (HAMPs) which include fatty acid-amino conjugates (Heil, 2009). Fatty acid-amino conjugates are present in the oral secretion of most lepidopteran larvae (Yoshinaga et al., 2010). Only few molecular mechanisms connecting light with herbivore attack are known. Observations have been made indicating that especially UV-B light has a positive effect on the plant responses to insect herbivores (Escobar-Bravo, Klinkhamer, & Leiss, 2017). For example, Caputo, Rutitzky, and Ballare (2006) showed that UV-B influences the attractiveness of *Arabidopsis* plants to diamondback moths (*Plutella xylostella*). They described that the beneficial effect of UV-B light on the reduction of egg number was compromised in the *jar1* mutant suggesting that jasmonic acid (JA) biosynthesis is required for the defence response. A similar beneficial effect of UV light was observed in the *defenseless1* tomato mutant, which is deficient in JA biosynthesis. Here, a strong activation of salicylic acid-associated defence responses by UV light after thrips infestation was observed (Escobar-Bravo et al., 2019). UV-B treatment also enhanced the resistance of *Arabidopsis* to *Spodoptera litura* herbivores through a JA-dependent mechanism (Qi et al., 2018). Radhika, Kost, Mithofer, and Boland (2010) demonstrated that in lima bean (*Phaseolus lunatus*) the JA-regulated secretion of extrafloral nectar attracting ants which protect plants against herbivores depends on light (Kazan & Manners, 2011). These examples illustrate that a close connection between herbivore resistance and UV-B signalling acting through jasmonic acid biosynthesis and signalling pathways exists.

## 5.3 | Shade and biotic stress responses

Low R:FR ratios are characteristic for shade and environments with densely standing plants resulting in a partial inactivation of PfrB. This causes the shade avoidance syndrome which is characterized by leaf

hyponasty, an increase in hypocotyl and internode elongation and extended petioles to gain as much light as possible (Sessa, Carabelli, Possenti, Morelli, & Ruberti, 2018; Yang & Li, 2017).

Under shade conditions, plant defence against pathogens and insects is weakened (Ballaré, 2014; Courbier & Pierik, 2019; Fernandez-Milmanda et al., 2020; McGuire & Agrawal, 2005). An overview of the signalling pathways involved in plant immunity under shade conditions is given in Figure 9. For instance, tobacco plants (*Nicotiana longiflora*) exposed to increased reflected far-red light, which occurs in crowded plant populations, result in an altered expression of defence-related genes, a decreased accumulation of herbivore-induced phenolic compounds and an improved performance of the specialist herbivore *Manduca sexta* (Izaguirre, Mazza, Biondini, Baldwin, & Ballaré, 2006). In addition, *Arabidopsis* resistance to *Botrytis cinerea* and *P. syringae* decreased after exposure to low red to far-red (R:FR) mimicking shade conditions (Cerrudo et al., 2012; De Wit et al., 2013). Consistently, it was found that *phyB Arabidopsis* mutants are more susceptible to the fungal pathogen *Fusarium oxysporum* than wild-type plants (Kazan & Manners, 2011) and tomato plants mutated in *phyB* are less resistant to *Spodoptera eridania* caterpillars or the thrips *Caliothrips phaseoli* (Izaguirre et al., 2006).

Under low R:FR, salicylic acid (SA)- and jasmonic acid (JA)-mediated pathogen defence responses are compromised. The decreased SA-induced resistance in low R:FR is associated with an inhibition of SA-responsive kinases. Especially NPR1 representing an important transcriptional regulator positively affecting SA-induced defence genes is not phosphorylated during low R:FR, thereby inhibiting transcription of target genes (De Wit et al., 2013) (Figure 9). Recently, it was shown that far-red light affects JA content directly by diminishing the level of JA-isoleucine derivatives in *Arabidopsis* subjected to *Spodoptera littoralis* caterpillars (Fernandez-Milmanda et al., 2020). The authors identified a sulphotransferase (ST2a), whose activity is strongly upregulated by far-red light in a *phyB*/PIF-dependent manner, to be responsible for the reduction of the active JA pool and thus causing an attenuation of JA response upon far-red illumination. Shade conditions also lower plant sensitivity to JA (Moreno, Tao, Chory, & Ballaré, 2009), resembling the repressive effect of SA on JA responses on the expression of defence genes such as *ERF1* and *PDF1.2* (Kazan & Manners, 2012; Pieterse, Leon-Reyes, Van der Ent, & Van Wees, 2009; Verhage, van Wees, & Pieterse, 2010). JA-regulated defence genes are induced by transcription factors like MYC2 which is repressed by jasmonate zim domain10 (JAZ10). Under low R:FR, or in *phyB* mutants, the stability of JAZ10 is enhanced resulting in weakened defence responses (Ballaré, 2014; Leone, Keller, Cerrudo, & Ballaré, 2014). In addition, Cerrudo et al. (2012) revealed that functional JAZ10 is necessary for a reduced defence of *Arabidopsis* plants against *B. cinerea* infection under shade conditions. In low R:FR, not only JAZ stability is higher, but also gibberellin activity is enhanced resulting in a reduction of DELLA functionality. As a consequence, JAZ proteins can interact with MYCs thereby preventing the transcription of target genes – a process which is normally prevented by DELLAs (Ballaré, 2014; Hou, Lee, Xia, Yan, & Yu, 2010; Navarro et al., 2008). This indicates that not only JA

and SA, but also gibberellin responds to shade and impacts defence responses in plants (Figure 9).

The emission of volatile organic compounds and extrafloral nectar is another plant defence against herbivory which is attenuated by shade conditions. In passionfruit (*Passiflora edulis*), the extrafloral nectar production triggered by herbivores is strongly repressed upon perception of low R:FR thereby reducing the attractiveness of passionfruit for herbivore predators (Izaguirre, Lazza, Astigueta, Ciarla, & Ballaré, 2013). Furthermore, far-red light negatively affects the JA-controlled extra floral nectar secretion in lima bean (*Phaseolus lunatus*) (Radhika et al., 2010) and attenuates the JA burst and latex content in common milkweed (*Asclepias syriaca*) following herbivore attack of *Danaus plexippus* caterpillars (Agrawal, Kearney, Hastings, & Ramsey, 2012). The volatile blend of both non-induced and methyl jasmonate-induced plants is altered (Kegge et al., 2013) in response to low R:FR. Inactivation of *phyB* in tomato resulted in the repression of direct anti-herbivore defences. In addition, it altered the pattern of volatile organic compounds emitted by methyl jasmonate-treated tomato plants making them more attractive for *Macrolophus pygmaeus* which feeds on herbivores of tomato (Cortés, Weldegegriss, Boccalandro, Dicke, & Ballaré, 2016). Thus, the quest for light through shade-avoidance responses might attract predators to diminish the disastrous effects of herbivores.

## 6 | CONCLUSIONS

In this review, we have described that light acts itself as a stressor and in addition regulates the outcome of numerous other abiotic and biotic stress responses. Plants have evolved complex crosstalk between light signalling and the different stress response pathways to survive and be prepared for future stress events. The increasing number of experimental work addressing this crosstalk suggests that this is a growing area of research, which will lead to many more insights in the role of light during plant responses to abiotic and biotic stresses in the future. Transfer of this knowledge to crop plants might enable us to boost plant resilience and immunity by simply adjusting the light environment in which plants grow.

### ACKNOWLEDGMENTS

We acknowledge funding by Deutsche Forschungsgemeinschaft (DFG) through Collaborative Research Centre 973 ([www.sfb973.de](http://www.sfb973.de)) and project Schm 814/29-1. There are no conflicts of interests. Open access funding enabled and organized by Projekt DEAL.

### ORCID

Venja M. Roerber  <https://orcid.org/0000-0002-6704-4206>

Thomas Schmülling  <https://orcid.org/0000-0001-5532-9645>

Anne Cortleven  <https://orcid.org/0000-0002-2195-7456>

### REFERENCES

Abuelsoud, W., Cortleven, A., & Schmülling, T. (2020). Photoperiod stress alters the cellular redox status and is associated with an increased

peroxidase and decreased catalase activity. *Journal of Plant Physiology*, in press, 253, 153252.

Agati, G., Azzarello, E., Pollastri, S., & Tattini, M. (2012). Flavonoids as anti-oxidants in plants: Location and functional significance. *Plant Science*, 196, 67–76.

Agrawal, A. A., Kearney, E. E., Hastings, A. P., & Ramsey, T. E. (2012). Attenuation of the jasmonate burst, plant defensive traits, and resistance to specialist monarch caterpillars on shaded common milkweed (*Asclepias syriaca*). *Journal of Chemical Ecology*, 38(7), 893–901.

Ahmad, M., & Cashmore, A. R. (1993). *HY4* gene of *A. thaliana* encodes a protein with characteristics of a blue-light photoreceptor. *Nature*, 366(6451), 162–166.

Ahres, M., Gierczik, K., Boldizsár, Á., Vitémvás, P., & Galiba, G. (2020). Temperature and light-quality-dependent regulation of freezing tolerance in barley. *Plants*, 9(1), E83.

Alonso-Blanco, C., Gomez-Mena, C., Llorente, F., Koornneef, M., Salinas, J., & Martinez-Zapater, J. M. (2005). Genetic and molecular analyses of natural variation indicate *CBF2* as a candidate gene for underlying a freezing tolerance quantitative trait locus in *Arabidopsis*. *Plant Physiology*, 139(3), 1304–1312.

Amisshah, L., Mohren, G. M., Kyereh, B., & Poorter, L. (2015). The effects of drought and shade on the performance, morphology and physiology of Ghanaian tree species. *PLoS One*, 10(4), e0121004.

Anjum, N. A., Khan, N. A., Sofo, A., Baier, M., & Kizek, R. (2016). Redox homeostasis managers in plants under environmental stresses. *Frontiers in Environmental Science*, 4, 35.

Apel, K., & Hirt, H. (2004). Reactive oxygen species: Metabolism, oxidative stress, and signal transduction. *Annual Review of Plant Biology*, 55, 373–399.

Arico, D., Legris, M., Castro, L., Garcia, C. F., Laino, A., Casal, J. J., & Mazzella, M. A. (2019). Neighbour signals perceived by phytochrome B increase thermotolerance in *Arabidopsis*. *Plant, Cell & Environment*, 42(9), 2554–2566.

Asada, K. (1999). The water-water cycle in chloroplasts: Scavenging of active oxygens and dissipation of excess photons. *Annual Review of Plant Physiology and Plant Molecular Biology*, 50, 601–639.

Asghar, M. A., Duab, J., Jiang, H., Lia, Y., Sun, X., Shang, J., ... Yang, W. (2020). Shade pretreatment enhanced drought resistance of soybean. *Environmental and Experimental Botany*, 171, 103952.

Baena-Gonzalez, E., & Aro, E. M. (2002). Biogenesis, assembly and turnover of photosystem II units. *Philosophical Transactions of the Royal Society of London. Series B, Biological Sciences*, 357(1426), 1451–1459.

Balfagon, D., Sengupta, S., Gomez-Cadenas, A., Fritsch, F. B., Azad, R. K., Mittler, R., & Zandalinas, S. I. (2019). Jasmonic acid is required for plant acclimation to a combination of high light and heat stress. *Plant Physiology*, 181(4), 1668–1682.

Ballaré, C. L. (2014). Light regulation of plant defense. *Annual Review of Plant Biology*, 65, 335–363.

Boccalandro, H. E., Rugnone, M. L., Moreno, J. E., Ploschuk, E. L., Serna, L., Yanovsky, M. J., & Casal, J. J. (2009). Phytochrome B enhances photosynthesis at the expense of water-use efficiency in *Arabidopsis*. *Plant Physiology*, 150(2), 1083–1092.

Bouly, J. P., Schleicher, E., Dionisio-Sese, M., Vandenbussche, F., Van Der Straeten, D., Bakrim, N., ... Ahmad, M. (2007). Cryptochrome blue light photoreceptors are activated through interconversion of flavin redox states. *The Journal of Biological Chemistry*, 282(13), 9383–9391.

Brelsford, C. C., Morales, L. O., Nezval, J., Kotilainen, T. K., Hartikainen, S. M., Aphalo, P. J., & Robson, T. M. (2019). Do UV-A radiation and blue light during growth prime leaves to cope with acute high light in photoreceptor mutants of *Arabidopsis thaliana*? *Physiologia Plantarum*, 165(3), 537–554.

Britt, A. (2002). Repair of damaged bases. *Arabidopsis Book*, 1, e0005. <https://doi.org/10.1199/tab.0005>

Brown, B. A., Cloix, C., Jiang, G. H., Kaiserli, E., Herzyk, P., Kliebenstein, D. J., & Jenkins, G. I. (2005). A UV-B-specific signaling

- component orchestrates plant UV protection. *Proceedings of the National Academy of Sciences of the United States of America*, 102(50), 18225–18230.
- Brown, B. A., & Jenkins, G. I. (2008). UV-B signaling pathways with different fluence-rate response profiles are distinguished in mature *Arabidopsis* leaf tissue by requirement for UVR8, HY5, and HYH. *Plant Physiology*, 146(2), 576–588.
- Canamero, R. C., Bakrim, N., Bouly, J. P., Garay, A., Dudkin, E. E., Habricot, Y., & Ahmad, M. (2006). Cryptochrome photoreceptors cry1 and cry2 antagonistically regulate primary root elongation in *Arabidopsis thaliana*. *Planta*, 224(5), 995–1003.
- Caputo, C., Rutitzky, M., & Ballare, C. L. (2006). Solar ultraviolet-B radiation alters the attractiveness of *Arabidopsis* plants to diamondback moths (*Plutella xylostella* L.): Impacts on oviposition and involvement of the jasmonic acid pathway. *Oecologia*, 149(1), 81–90.
- Casal, J. J. (2013). Photoreceptor signaling networks in plant responses to shade. *Annual Review of Plant Biology*, 64, 403–427.
- Casal, J., Balasubramanian, S. (2019). Thermomorphogenesis. *Annual Review of Plant Biology*, 70(1), 321–346. <http://dx.doi.org/10.1146/annurev-arplant-050718-095919>.
- Catalá, R., Medina, J., & Salinas, J. (2011). Integration of low temperature and light signaling during cold acclimation response in *Arabidopsis*. *PNAS*, 108(39), 16475–16480.
- Cecchini, E., Geri, C., Love, A. J., Coupland, G., Covey, S. N., & Milner, J. J. (2002). Mutations that delay flowering in *Arabidopsis* de-couple symptom response from cauliflower mosaic virus accumulation during infection. *Molecular Plant Pathology*, 3(2), 81–90.
- Cerrudo, I., Keller, M. M., Cargnel, M. D., Demkura, P. V., de Wit, M., Patitucci, M. S., ... Ballare, C. L. (2012). Low red/far-red ratios reduce *Arabidopsis* resistance to *Botrytis cinerea* and jasmonate responses via a CO11-JAZ10-dependent, salicylic acid-independent mechanism. *Plant Physiology*, 158(4), 2042–2052.
- Chandra-Shekara, A. C., Gupte, M., Navarre, D., Raina, S., Raina, R., Klessig, D., & Kachroo, P. (2006). Light-dependent hypersensitive response and resistance signaling against Turnip Crinkle Virus in *Arabidopsis*. *The Plant Journal*, 45(3), 320–334.
- Chisholm, S. T., Coaker, G., Day, B., & Staskawicz, B. J. (2006). Host-microbe interactions: Shaping the evolution of the plant immune response. *Cell*, 124(4), 803–814.
- Christie, J. M. (2007). Phototropin blue-light receptors. *Annual Review of Plant Biology*, 58, 21–45.
- Christie, J. M., Blackwood, L., Petersen, J., & Sullivan, S. (2015). Plant flavoprotein photoreceptors. *Plant & Cell Physiology*, 56(3), 401–413.
- Christie, J. M., Salomon, M., Nozue, K., Wada, M., & Briggs, W. R. (1999). LOV (light, oxygen, or voltage) domains of the blue-light photoreceptor phototropin (*nph1*): Binding sites for the chromophore flavin mononucleotide. *Proceedings of the National Academy of Sciences of the United States of America*, 96(15), 8779–8783.
- Chung, B., Balcerowicz, M., Di Antonio, M., Jaeger, K., Geng, F., ... Wigge, P. A. (2020). An RNA thermoswitch regulates daytime growth in *Arabidopsis*. *Nature Plants*, 6(5), 522–532.
- Conrath, U. (2006). Systemic acquired resistance. *Plant Signaling & Behavior*, 1(4), 179–184.
- Consentino, L., Lambert, S., Martino, C., Jourdan, N., Bouchet, P. E., Witczak, J., ... Ahmad, M. (2015). Blue-light dependent reactive oxygen species formation by *Arabidopsis* cryptochrome may define a novel evolutionarily conserved signaling mechanism. *The New Phytologist*, 206(4), 1450–1462.
- Correll, M. J., Coveney, K. M., Raines, S. V., Mullen, J. L., Hangarter, R. P., & Kiss, J. Z. (2003). Phytochromes play a role in phototropism and gravitropism in *Arabidopsis* roots. *Advances in Space Research*, 31(10), 2203–2210.
- Cortés, L. E., Weldegegrs, B. T., Boccalandro, H. E., Dicke, M., & Ballaré, C. (2016). Trading direct for indirect defense? Phytochrome B inactivation in tomato attenuates direct anti-herbivore defense whilst enhancing volatile-mediated attraction of predators. *New Phytologist*, 212(4), 1057–1071.
- Courcier, S., & Pierik, R. (2019). Canopy light quality modulates stress responses in plants. *iScience*, 22, 441–452.
- Crawford, T., Lehotai, N., & Strand, A. (2018). The role of retrograde signals during plant stress responses. *Journal of Experimental Botany*, 69(11), 2783–2795.
- Daszkowska-Golec, A., & Szarejko, I. (2013). Open or close the gate-stomata action under the control of phytohormones in drought stress conditions. *Frontiers in Plant Science*, 4, 138.
- Davey, M. P., Susanti, N. I., Wargent, J. J., Findlay, J. E., Paul Quick, W., Paul, N. D., & Jenkins, G. I. (2012). The UV-B photoreceptor UVR8 promotes photosynthetic efficiency in *Arabidopsis thaliana* exposed to elevated levels of UV-B. *Photosynthesis Research*, 114(2), 121–131.
- De Wit, M., Spoel, S. H., Sanchez-Perez, G. F., Gommers, C. M. M., Pieterse, C. M. J., Voesenek, L., & Pierik, R. (2013). Perception of low red:far-red ratio compromises both salicylic acid- and jasmonic acid-dependent pathogen defences in *Arabidopsis*. *The Plant Journal*, 75(1), 90–103.
- De Wit, P. (1997). Pathogen avirulence and plant resistance: A key role for recognition. *Trends in Plant Science*, 2, 452–458.
- De Wit, P. (2007). How plants recognize pathogens and defend themselves. *Cellular and Molecular Life Sciences*, 64, 2726–2732.
- Delprato, M. L., Krapp, A. R., & Carrillo, N. (2015). Green light to plant responses to pathogens: The role of chloroplast light-dependent signaling in biotic stress. *Photochemistry and Photobiology*, 91(5), 1004–1011.
- Demkura, P. V., & Ballare, C. L. (2012). UVR8 mediates UV-B-induced *Arabidopsis* defense responses against *Botrytis cinerea* by controlling sinapate accumulation. *Molecular Plant*, 5(3), 642–652.
- Devlin, P. F., & Kay, S. A. (2000). Cryptochromes are required for phytochrome signaling to the circadian clock but not for rhythmicity. *Plant Cell*, 12(12), 2499–2510.
- Dickinson, P. J., Kumar, M., Martinho, C., Yoo, S. J., Lan, H., Artavanis, G., ... Wigge, P. A. (2018). Chloroplast signaling gates thermotolerance in *Arabidopsis*. *Cell Reports*, 22(7), 1657–1665.
- Ding, L., Wang, S., Song, Z. T., Jiang, Y., Han, J. J., Lu, S. J., ... Liu, J. X. (2018). Two B-box domain proteins, BBX18 and BBX23, interact with ELF3 and regulate thermomorphogenesis in *Arabidopsis*. *Cell Reports*, 25(7), 1718–1728 e1714.
- Dong, M. A., Farre, E. M., & Thomashow, M. F. (2011). Circadian clock-associated 1 and late elongated hypocotyl regulate expression of the C-repeat binding factor (CBF) pathway in *Arabidopsis*. *Proceedings of the National Academy of Sciences of the United States of America*, 108(17), 7241–7246.
- Edelman, M., & Mattoo, A. K. (2008). D1-protein dynamics in photosystem II: The lingering enigma. *Photosynthesis Research*, 98(1–3), 609–620.
- El-Esawi, M., Arthaut, L. D., Jourdan, N., d'Harlingue, A., Link, J., Martino, C. F., & Ahmad, M. (2017). Blue-light induced biosynthesis of ROS contributes to the signaling mechanism of *Arabidopsis* cryptochrome. *Scientific Reports*, 7(1), 13875.
- Emiliani, J., Grotewold, E., Falcone Ferreyra, M. L., & Casati, P. (2013). Flavonols protect *Arabidopsis* plants against UV-B deleterious effects. *Molecular Plant*, 6(4), 1376–1379.
- Escobar-Bravo, R., Chen, G., Grosse, K., Van Dam, N. M., Leiss, K. A., & Klinkhamer, P. G. L. (2019). Ultraviolet radiation enhances salicylic acid-mediated defense signaling and resistance to *Pseudomonas syringae* DC3000 in a jasmonic acid-deficient tomato mutant. *Plant Signaling & Behavior*, 14(4), e1581560.
- Escobar-Bravo, R., Klinkhamer, P. G., & Leiss, K. A. (2017). Interactive effects of UV-B light with abiotic factors on plant growth and chemistry, and their consequences for defense against arthropod herbivores. *Frontiers in Plant Science*, 8, 278.
- Evrard A., Ndatimana T., Eulgem T. (2009). FORCA, a promoter element that responds to crosstalk between defense and light signaling. *BMC Plant Biology*, 9(1), 2. <http://dx.doi.org/10.1186/1471-2229-9-2>.

- Ezer, D., Jung, J. H., Lan, H., Biswas, S., Gregoire, L., Box, M. S., ... Wigge, P. A. (2017). The evening complex coordinates environmental and endogenous signals in Arabidopsis. *Nature Plants*, 3, 17087.
- Fahad, S., Bajwa, A. A., Nazir, U., Anjum, S. A., Farooq, A., Zohaib, A., ... Huang, J. (2017). Crop production under drought and heat stress: Plant responses and management options. *Frontiers in Plant Science*, 8, 1147.
- Favory, J. J., Stec, A., Gruber, H., Rizzini, L., Oravec, A., Funk, M., ... Ulm, R. (2009). Interaction of COP1 and UVR8 regulates UV-B-induced photomorphogenesis and stress acclimation in Arabidopsis. *The EMBO Journal*, 28(5), 591–601.
- Fernandez, A. P., & Strand, A. (2008). Retrograde signaling and plant stress: Plastid signals initiate cellular stress responses. *Current Opinion in Plant Biology*, 11(5), 509–513. <https://doi.org/10.1016/j.pbi.2008.06.002>.
- Fernandez-Milmanda, G. L., Crocco, C. D., Reichelt, M., Mazza, C. A., Kollner, T. G., Zhang, T., ... Ballaré, C. L. (2020). A light-dependent molecular link between competition cues and defence responses in plants. *Nature Plants*, 6(3), 223–230.
- Fiorucci, A.-S., Galvao, V. C., Ince, Y. C., Boccaccini, A., Goyal, A., ... Frankhauser, C. (2019). Phytochrome interacting FACTOR 7 is important for early responses to elevated temperature in Arabidopsis seedlings. *New Phytologist*, 226(1), 50–58.
- Fowler, S. G., Cook, D., & Thomashow, M. F. (2005). Low temperature induction of Arabidopsis CBF1, 2, and 3 is gated by the circadian clock. *Plant Physiology*, 137(3), 961–968.
- Frank, M., Cortleven, A., Novak, O., & Schmölling, T. (2020). Root-derived trans-zeatin cytokinin protects Arabidopsis plants against photoperiod stress. *Plant, Cell & Environment*, in press, 43, 2637–2649. <https://doi.org/10.1101/2020.03.05.978221>
- Franklin, K. A., & Whitelam, G. C. (2007a). Light-quality regulation of freezing tolerance in Arabidopsis thaliana. *Nature Genetics*, 39(11), 1410–1413.
- Franklin, K. A., & Whitelam, G. C. (2007b). Phytochrome A function in red light sensing. *Plant Signaling & Behavior*, 2(5), 383–385.
- Gallagher, S., Short, T. W., Ray, P. M., Pratt, L. H., & Briggs, W. R. (1988). Light-mediated changes in two proteins found associated with plasma membrane fractions from pea stem sections. *Proceedings of the National Academy of Sciences of the United States of America*, 85(21), 8003–8007.
- Ganguly, D. R., Crisp, P. A., Eichten, S. R., & Pogson, B. J. (2018). Maintenance of pre-existing DNA methylation states through recurring excess-light stress. *Plant, Cell & Environment*, 41(7), 1657–1672.
- Genoud, T., Buchala, A. J., Chua, N. H., & Metraux, J. P. (2002). Phytochrome signalling modulates the SA-perceptive pathway in Arabidopsis. *The Plant Journal*, 31(1), 87–95.
- Gonzalez, C. V., Ibarra, S. E., Piccoli, P. N., Botto, J. F., & Bocalandro, H. E. (2012). Phytochrome B increases drought tolerance by enhancing ABA sensitivity in Arabidopsis thaliana. *Plant, Cell & Environment*, 35(11), 1958–1968.
- Griebel, T., & Zeier, J. (2008). Light regulation and daytime dependency of inducible plant defenses in Arabidopsis: Phytochrome signaling controls systemic acquired resistance rather than local defense. *Plant Physiology*, 147(2), 790–801.
- Guo, H., Yang, H., Mockler, T. C., & Lin, C. (1998). Regulation of flowering time by Arabidopsis photoreceptors. *Science*, 279(5355), 1360–1363.
- Guy, C., Kaplan, F., Kopka, J., Selbig, J., & Hinch, D. K. (2008). Metabolomics of temperature stress. *Physiologia Plantarum*, 132(2), 220–235.
- Han, S. H., Park, Y. J., & Park, C. M. (2019a). Light primes the thermally induced detoxification of reactive oxygen species during development of thermotolerance in Arabidopsis. *Plant & Cell Physiology*, 60(1), 230–241.
- Han, S. H., Park, Y. J., & Park, C. M. (2019b). Light priming of thermotolerance development in plants. *Plant Signaling & Behavior*, 14(1), 1554469.
- Harvaux, M., & Kloppstech, K. (2001). The protective functions of carotenoid and flavonoid pigments against excess visible radiation at chilling temperature investigated in Arabidopsis npq and tt mutants. *Planta*, 213(6), 953–966.
- Hayes, S., Sharma, A., Fraser, D. P., Trevisan, M., Cragg-Barber, C. K., Tavidou, E., ... Franklin, K. A. (2017). UV-B perceived by the UVR8 photoreceptor inhibits plant thermomorphogenesis. *Current Biology*, 27(1), 120–127.
- He, Y., Li, Y., Cui, L., Xie, L., Zheng, C., Zhou, G., ... Xie, X. (2016). Phytochrome B negatively affects cold tolerance by regulating OsDREB1 gene expression through phytochrome interacting factor-like protein OsPIL16 in rice. *Frontiers in Plant Science*, 7, 1963.
- Heijde, M., & Ulm, R. (2013). Reversion of the Arabidopsis UV-B photoreceptor UVR8 to the homodimeric ground state. *Proceedings of the National Academy of Sciences of the United States of America*, 110(3), 1113–1118.
- Heil, M. (2009). Damaged-self recognition in plant herbivore defence. *Trends in Plant Science*, 14(7), 356–363.
- Hideg, E., Jansen, M. A., & Strid, A. (2013). UV-B exposure, ROS, and stress: Inseparable companions or loosely linked associates? *Trends in Plant Science*, 18(2), 107–115.
- Holmes, M. G., Smith, H. (1977). The function of phytochrome in the natural environment – I. characterization of daylight for studies in photomorphogenesis and photoperiodism. *Photochemistry and Photobiology*, 25(6), 533–538. <http://dx.doi.org/10.1111/j.1751-1097.1977.tb09124.x>.
- Holt, N. E., Fleming, G. R., & Niyogi, K. K. (2004). Toward an understanding of the mechanism of nonphotochemical quenching in green plants. *Biochemistry*, 43(26), 8281–8289.
- Hou, X., Lee, L. Y., Xia, K., Yan, Y., & Yu, H. (2010). DELLAs modulate jasmonate signaling via competitive binding to JAZs. *Developmental Cell*, 19(6), 884–894.
- Huang, J., Zhao, X., & Chory, J. (2019). The Arabidopsis Transcriptome Responds Specifically and Dynamically to High Light Stress. *Cell Reports*, 29(12), 4186–4199.
- Ito, S., Song, Y. H., & Imaizumi, T. (2012). LOV domain-containing F-box proteins: Light-dependent protein degradation modules in Arabidopsis. *Molecular Plant*, 5(3), 573–582.
- Izaguirre, M. M., Lazza, C., Astigueta, M. S., Ciarla, A. M., & Ballaré, C. L. (2013). No time for candy: Passionfruit (*Passiflora edulis*) plants down-regulate damage-induced extra floral nectar production in response to light signals of competition. *Oecologia*, 173(1), 213–221.
- Izaguirre, M. M., Mazza, C. A., Biondini, M., Baldwin, I. T., & Ballaré, C. L. (2006). Remote sensing of future competitors: Impacts on plant defenses. *Proceedings of the National Academy of Sciences of the United States of America*, 103(18), 7170–7174.
- Jelenska, J., Yao, N., Vinatzer, B. A., Wright, C. M., Brodsky, J. L., & Greenberg, J. T. (2007). A J domain virulence effector of *Pseudomonas syringae* remodels host chloroplasts and suppresses defenses. *Current Biology*, 17(6), 499–508.
- Jeong, R. D., Chandra-Shekara, A. C., Barman, S. R., Navarre, D., Klessig, D. F., Kachroo, A., & Kachroo, P. (2010). Cryptochrome 2 and phototropin 2 regulate resistance protein-mediated viral defense by negatively regulating an E3 ubiquitin ligase. *Proceedings of the National Academy of Sciences of the United States of America*, 107(30), 13538–13543.
- Jeong, R. D., Kachroo, A., & Kachroo, P. (2010). Blue light photoreceptors are required for the stability and function of a resistance protein mediating viral defense in Arabidopsis. *Plant Signaling & Behavior*, 5(11), 1504–1509.
- Jiang, B., Shi, Y., Peng, Y., Jia, Y., Yan, Y., Dong, X., ... Yang, S. (2020). Cold-induced CBF-PIF3 interaction enhances freezing tolerance by stabilizing the phyB thermosensor in Arabidopsis. *Molecular Plant*. [https://doi.org/10.1016/j.molp.2020.04.00613\(6\)](https://doi.org/10.1016/j.molp.2020.04.00613(6)), 894–906.



- Jiang, B., Shi, Y., Zhang, X., Xin, X., Qi, L., Guo, H., ... Yang, S. (2017). PIF3 is a negative regulator of the CBF pathway and freezing tolerance in *Arabidopsis*. *Proceedings of the National Academy of Sciences of the United States of America*, 114(32), E6695–E6702.
- Jones, J. D., & Dangl, J. L. (2006). The plant immune system. *Nature*, 444(7117), 323–329.
- Joshi, R., Wani, S. H., Singh, B., Bohra, A., Dar, Z. A., Lone, A. A., ... Singla-Pareek, S. L. (2016). Transcription factors and plants response to drought stress: Current understanding and future directions. *Frontiers in Plant Science*, 7, 1029.
- Jourdan, N., Martino, C. F., El-Esawi, M., Witzczak, J., Bouchet, P. E., d'Harlingue, A., & Ahmad, M. (2015). Blue-light dependent ROS formation by *Arabidopsis* cryptochrome-2 may contribute toward its signalling role. *Plant Signaling & Behavior*, 10(8), e1042647.
- Jung, J. H., Domijan, M., Klose, C., Biswas, S., Ezer, D., Gao, M., ... Wigge, P. A. (2016). Phytochromes function as thermosensors in *Arabidopsis*. *Science*, 354(6314), 886–889.
- Kampinga, H. H., Brunsting, J. F., Stege, G. J., Burgman, P. W., & Konings, A. W. (1995). Thermal protein denaturation and protein aggregation in cells made thermotolerant by various chemicals: Role of heat shock proteins. *Experimental Cell Research*, 219(2), 536–546.
- Kang, C. Y., Lian, H. L., Wang, F. F., Huang, J. R., & Yang, H. Q. (2009). Cryptochromes, phytochromes, and COP1 regulate light-controlled stomatal development in *Arabidopsis*. *Plant Cell*, 21(9), 2624–2641.
- Kangasjärvi, S., Neukermans, J., Li, S., Aro, E. M., & Noctor, G. (2012). Photosynthesis, photorespiration, and light signalling in defence responses. *Journal of Experimental Botany*, 63(4), 1619–1636.
- Karpinski, S., Gabrys, H., Mateo, A., Karpinska, B., & Mullineaux, P. M. (2003). Light perception in plant disease defence signalling. *Current Opinion in Plant Biology*, 6(4), 390–396.
- Kazan, K., & Manners, J. M. (2011). The interplay between light and jasmonate signalling during defence and development. *Journal of Experimental Botany*, 62(12), 4087–4100.
- Kazan, K., & Manners, J. M. (2012). JAZ repressors and the orchestration of phytohormone crosstalk. *Trends in Plant Science*, 17(1), 22–31.
- Kegge, W., Weldegergis, B. T., Soler, R., Vergeer-Van Eijk, M., Dicke, M., ... Pierik, R. (2013). Canopy light cues affect emission of constitutive and methyl jasmonate-induced volatile organic compounds in *Arabidopsis thaliana*. *The New Phytologist*, 200(3), 861–874.
- Kidokoro, S., Maruyama, K., Nakashima, K., Imura, Y., Narusaka, Y., Shinwari, Z. K., ... Yamaguchi-Shinozaki, K. (2009). The phytochrome-interacting factor PIF7 negatively regulates DREB1 expression under circadian control in *Arabidopsis*. *Plant Physiology*, 151(4), 2046–2057.
- Kim, H. J., Kim, Y. K., Park, J. Y., & Kim, J. (2002). Light signalling mediated by phytochrome plays an important role in cold-induced gene expression through the C-repeat/dehydration responsive element (C/DRE) in *Arabidopsis thaliana*. *Plant Journal*, 29(6), 693–704.
- Kim, J. S., Mizoi, J., Kidokoro, S., Maruyama, K., Nakajima, J., Nakashima, K., ... Yamaguchi-Shinozaki, K. (2012). *Arabidopsis* growth-regulating factor7 functions as a transcriptional repressor of abscisic acid- and osmotic stress-responsive genes, including DREB2A. *Plant Cell*, 24(8), 3393–3405.
- Kleine, T., Kindgren, P., Benedict, C., Hendrickson, L., & Strand, A. (2007). Genome-wide gene expression analysis reveals a critical role for cryptochrome1 in the response of *Arabidopsis* to high irradiance. *Plant Physiology*, 144(3), 1391–1406.
- Kliebenstein, D. J., Lim, J. E., Landry, L. G., & Last, R. L. (2002). *Arabidopsis* UVR8 regulates ultraviolet-B signal transduction and tolerance and contains sequence similarity to human regulator of chromatin condensation 1. *Plant Physiology*, 130(1), 234–243.
- Koini, M. A., Alvey, L., Allen, T., Tilley, C. A., Harberd, N. P., Whitelam, G. C., & Franklin, K. A. (2009). High temperature-mediated adaptations in plant architecture require the bHLH transcription factor PIF4. *Current Biology*, 19(5), 408–413.
- Kono, M., Noguchi, K., & Terashima, I. (2014). Roles of the cyclic electron flow around PSI (CEF-PSI) and O(2)-dependent alternative pathways in regulation of the photosynthetic electron flow in short-term fluctuating light in *Arabidopsis thaliana*. *Plant & Cell Physiology*, 55(5), 990–1004.
- Kono, M., & Terashima, I. (2014). Long-term and short-term responses of the photosynthetic electron transport to fluctuating light. *Journal of Photochemistry and Photobiology. B*, 137, 89–99.
- Kono, M., & Terashima, I. (2016). Elucidation of photoprotective mechanisms of PSI against fluctuating light photoinhibition. *Plant & Cell Physiology*, 57(7), 1405–1414.
- Kono, M., Yamori, W., Suzuki, Y., & Terashima, I. (2017). Photoprotection of PSI by far-red light against the fluctuating light-induced photoinhibition in *Arabidopsis thaliana* and field-grown plants. *Plant & Cell Physiology*, 58(1), 35–45.
- Kostaki, K. I., Coupel-Ledru, A., Bonnell, V. C., Gustavsson, M., Sun, P., McLaughlin, F. J., ... Franklin, K. A. (2020). Guard cells integrate light and temperature signals to control stomatal aperture. *Plant Physiology*, 182(3), 1404–1419.
- Kudo, M., Kidokoro, S., Yoshida, T., Mizoi, J., Todaka, D., ... Yamaguchi-Shinozaki, K. (2017). Double overexpression of DREB and PIF transcription factors improves drought stress tolerance and cell elongation in transgenic plants. *Plant Biotechnology Journal*, 15(4), 458–471.
- Kudoh, H., & Sonoike, K. (2002). Irreversible damage to photosystem I by chilling in the light: Cause of the degradation of chlorophyll after returning to normal growth temperature. *Planta*, 215(4), 541–548.
- Larkindale, J., Hall, J. D., Knight, M. R., & Vierling, E. (2005). Heat stress phenotypes of *Arabidopsis* mutants implicate multiple signaling pathways in the acquisition of thermotolerance. *Plant Physiology*, 138(2), 882–897.
- Larkindale, J., & Knight, M. R. (2002). Protection against heat stress-induced oxidative damage in *Arabidopsis* involves calcium, abscisic acid, ethylene, and salicylic acid. *Plant Physiology*, 128(2), 682–695.
- Larkindale, J., & Vierling, E. (2008). Core genome responses involved in acclimation to high temperature. *Plant Physiology*, 146(2), 748–761.
- Lau, O. S., & Deng, X. W. (2010). Plant hormone signaling lightens up: Integrators of light and hormones. *Current Opinion in Plant Biology*, 13(5), 571–577.
- Lee, C. M., & Thomashow, M. F. (2012). Photoperiodic regulation of the C-repeat binding factor (CBF) cold acclimation pathway and freezing tolerance in *Arabidopsis thaliana*. *Proceedings of the National Academy of Sciences of the United States of America*, 109(37), 15054–15059.
- Legris, M., Klose, C., Burgie, E. S., Rojas, C. C., Neme, M., Hiltbrunner, A., ... Casal, J. J. (2016). Phytochrome B integrates light and temperature signals in *Arabidopsis*. *Science*, 354(6314), 897–900.
- Leone, M., Keller, M. M., Cerrudo, I., & Ballare, C. L. (2014). To grow or defend? Low red: Far-red ratios reduce jasmonate sensitivity in *Arabidopsis* seedlings by promoting DELLA degradation and increasing JAZ10 stability. *The New Phytologist*, 204(2), 355–367.
- Levitt, J. (1980). *Responses of plants to environmental stresses*, New York, NY, Academic Press.
- Li, B., Gao, K., Ren, H., & Tang, W. (2018). Molecular mechanisms governing plant responses to high temperatures. *Journal of Integrative Plant Biology*, 60(9), 757–779.
- Li, J., Li, G., Wang, H., & Wang Deng, X. (2011). Phytochrome signaling mechanisms. *Arabidopsis Book*, 9, e0148.
- Li, N., Teranishi, M., Yamaguchi, H., Matsushita, T., Watahiki, M. K., Tsuge, T., ... Hidema, J. (2015). UV-B-induced CPD photolyase gene expression is regulated by UVR8-dependent and -independent pathways in *Arabidopsis*. *Plant & Cell Physiology*, 56(10), 2014–2023.
- Liang, T., Mei, S., Shi, C., Yang, Y., Peng, Y., Ma, L., ... Liu, H. (2018). UVR8 interacts with BES1 and BIM1 to regulate transcription and photomorphogenesis in *Arabidopsis*. *Developmental Cell*, 44(4), 512–523 e515.
- Lin, C. (2000). Photoreceptors and regulation of flowering time. *Plant Physiology*, 123(1), 39–50.

- Liu, H., Liu, B., Zhao, C., Pepper, M., & Lin, C. (2011). The action mechanisms of plant cryptochromes. *Trends in Plant Science*, 16(12), 684–691.
- Liu, H., Yu, X., Li, K., Klejnot, J., Yang, H., Lisiero, D., & Lin, C. (2008). Photoexcited CRY2 interacts with CIB1 to regulate transcription and floral initiation in Arabidopsis. *Science*, 322(5907), 1535–1539.
- Liu, Z., Zhang, Y., Wang, J., Li, P., Zhao, C., Chen, Y., & Bi, Y. (2015). Phytochrome-interacting factors PIF4 and PIF5 negatively regulate anthocyanin biosynthesis under red light in Arabidopsis seedlings. *Plant Science*, 238, 64–72.
- Lozano J. C., & Sequeira, L. (1970). Differentiation of races of *Pseudomonas solanacearum* by a leaf infiltration technique. *Phytopathology*, 60(5), 833. <http://dx.doi.org/10.1094/phyto-60-833>.
- Ma, D., Li, X., Guo, Y., Chu, J., Fang, S., Yan, C., ... Liu, H. (2016). Cryptochrome 1 interacts with PIF4 to regulate high temperature-mediated hypocotyl elongation in response to blue light. *Proceedings of the National Academy of Sciences of the United States of America*, 113(1), 224–229.
- Mahmood, T., Khalid, S., Abdullah, M., Ahmed, Z., Shah, M. K. N., Ghafoor, A., & Du, X. (2019). Insights into drought stress signaling in plants and the molecular genetic basis of cotton drought tolerance. *Cell*, 9(1), 105.
- Maibam, P., Nawkar, G., Park, J., Sahi, V. P., Lee, S. Y., & Kang, C. H. (2013). The influence of light quality, circadian rhythm, and photoperiod on the CBF-mediated freezing tolerance. *International Journal of Molecular Sciences*, 14(6), 11527–11543.
- Maier, A., & Hoecker, U. (2015). COP1/SPA ubiquitin ligase complexes repress anthocyanin accumulation under low light and high light conditions. *Plant Signaling & Behavior*, 10(1), e970440.
- Mao, J., Zhang, Y. C., Sang, Y., Li, Q. H., & Yang, H. Q. (2005). A role for Arabidopsis cryptochromes and COP1 in the regulation of stomatal opening. *Proceedings of the National Academy of Sciences of the United States of America*, 102(34), 12270–12275.
- Matthews, J. S. A., Vialat-Chabrand, S., & Lawson, T. (2020). Role of blue and red light in stomatal dynamic behaviour. *Journal of Experimental Botany*, 71(7), 2253–2269.
- McGuire, R., & Agrawal, A. A. (2005). Trade-offs between the shade-avoidance response and plant resistance to herbivores? Test with mutant *Cucumis sativus*. *Functional Ecology*, 19, 1025–1031.
- Mittler, R., Finka, A., & Goloubinoff, P. (2012). How do plants feel the heat? *Trends in Biochemical Sciences*, 37(3), 118–125.
- Mittler, R., Vanderauwera, S., Gollery, M., & Van Breusegem, F. (2004). Reactive oxygen gene network of plants. *Trends in Plant Science*, 9(10), 490–498.
- Moreno, J. E., Tao, Y., Chory, J., & Ballare, C. L. (2009). Ecological modulation of plant defense via phytochrome control of jasmonate sensitivity. *Proceedings of the National Academy of Sciences of the United States of America*, 106(12), 4935–4940.
- Mühlenbock P., Szechyńska-Hebda M., Płaszczycza M., Baudo M., Mateo A., Mullineaux P.M., Parker J. E., Karpińska B., Karpiński S. (2008). Chloroplast signaling and LESION SIMULATING DISEASE1 regulate crosstalk between light acclimation and immunity in Arabidopsis. *The Plant Cell*, 20(9), 2339–2356. <http://dx.doi.org/10.1105/tpc.108.059618>.
- Müller-Xing, R., Xing, Q., & Goodrich, J. (2014). Footprints of the sun: Memory of UV and light stress in plants. *Frontiers in Plant Science*, 5, 474.
- Munekage, Y., Hojo, M., Meurer, J., Endo, T., Tasaka, M., & Shikanai, T. (2002). PGR5 is involved in cyclic electron flow around photosystem I and is essential for photoprotection in Arabidopsis. *Cell*, 110(3), 361–371.
- Murata, N., Takahashi, S., Nishiyama, Y., & Allakhverdiev, S. I. (2007). Photoinhibition of photosystem II under environmental stress. *Biochimica et Biophysica Acta*, 1767(6), 414–421.
- Nagy, F., & Schäfer, E. (2002). Phytochromes control photomorphogenesis by differentially regulated, interacting signaling pathways in higher plants. *Annual Review of Plant Biology*, 53, 329–355.
- Nakashima, K., Yamaguchi-Shinozaki, K., & Shinozaki, K. (2014). The transcriptional regulatory network in the drought response and its crosstalk in abiotic stress responses including drought, cold, and heat. *Frontiers in Plant Science*, 5, 170.
- Navarro, L., Bari, R., Achard, P., Lison, P., Nemri, A., Harberd, N. P., & Jones, J. D. (2008). DELLAs control plant immune responses by modulating the balance of jasmonic acid and salicylic acid signaling. *Current Biology*, 18(9), 650–655.
- Nieto, C., Lopez-Salmeron, V., Daviere, J. M., & Prat, S. (2015). ELF3-PIF4 interaction regulates plant growth independently of the Evening Complex. *Current Biology*, 25(2), 187–193.
- Nitschke, S., Cortleven, A., Iven, T., Feussner, I., Havaux, M., Riefler, M., & Schmölling, T. (2016). Circadian stress regimes affect the circadian clock and cause jasmonic acid-dependent cell death in cytokinin-deficient Arabidopsis plants. *Plant Cell*, 28(7), 1616–1639.
- Nitschke, S., Cortleven, A., & Schmölling, T. (2017). Novel stress in plants by altering the photoperiod. *Trends in Plant Science*, 22(11), 913–916.
- Nomura, H., Komori, T., Uemura, S., Kanda, Y., Shimotani, K., Nakai, K., ... Shiina, T. (2012). Chloroplast-mediated activation of plant immune signalling in Arabidopsis. *Nature Communications*, 3, 926.
- Ohnishi, N., Allakhverdiev, S. I., Takahashi, S., Higashi, S., Watanabe, M., Nishiyama, Y., & Murata, N. (2005). Two-step mechanism of photo-damage to photosystem II: Step 1 occurs at the oxygen-evolving complex and step 2 occurs at the photochemical reaction center. *Biochemistry*, 44(23), 8494–8499.
- Oikawa, K., Kasahara, M., Kiyosue, T., Kagawa, T., Suetsugu, N., Takahashi, F., ... Wada, M. (2003). Chloroplast unusual positioning1 is essential for proper chloroplast positioning. *Plant Cell*, 15(12), 2805–2815.
- Outlaw, W. H. J. (2003). Integration of cellular and physiological functions of guard cells. *Critical Reviews in Plant Sciences*, 22(6), 503–529.
- Paik, I., & Huq, E. (2019). Plant photoreceptors: Multi-functional sensory proteins and their signaling networks. *Seminars in Cell & Developmental Biology*, 92, 114–121.
- Pareek, A., Khurana, A., Sharma, A. K., & Kumar, R. (2017). An overview of signaling regulons during cold stress tolerance in plants. *Current Genomics*, 18(6), 498–511.
- Pierik, R., & de Wit, M. (2014). Shade avoidance: Phytochrome signalling and other aboveground neighbour detection cues. *Journal of Experimental Botany*, 65(11), 2815–2824.
- Pieterse, C. M., Leon-Reyes, A., Van der Ent, S., & Van Wees, S. C. (2009). Networking by small-molecule hormones in plant immunity. *Nature Chemical Biology*, 5(5), 308–316.
- Pospisil, P. (2016). Production of Reactive Oxygen Species by Photosystem II as a Response to Light and Temperature Stress. *Frontiers in Plant Science*, 7, 1950.
- Qi, J., Zhang, M., Lu, C., Hettenhausen, C., Tan, Q., Cao, G., ... Wu, J. (2018). Ultraviolet-B enhances the resistance of multiple plant species to lepidopteran insect herbivory through the jasmonic acid pathway. *Scientific Reports*, 8(1), 277.
- Quint, M., Delker, C., Franklin, K. A., Wigge, P. A., Halliday, K. J., & van Zanten, M. (2016). Molecular and genetic control of plant thermomorphogenesis. *Nature Plants*, 2, 15190.
- Radhika, V., Kost, C., Mithofer, A., & Boland, W. (2010). Regulation of extrafloral nectar secretion by jasmonates in lima bean is light dependent. *Proceedings of the National Academy of Sciences of the United States of America*, 107(40), 17228–17233.
- Rai, N., Neugart, S., Yan, Y., Wang, F., Siipola, S. M., Lindfors, A. V., ... Aphalo, P. J. (2019). How do cryptochromes and UVR8 interact in natural and simulated sunlight? *Journal of Experimental Botany*, 70(18), 4975–4990.

- Rizzini, L., Favory, J. J., Cloix, C., Faggionato, D., O'Hara, A., Kaiserli, E., ... Ulm, R. (2011). Perception of UV-B by the Arabidopsis UVR8 protein. *Science*, 332(6025), 103–106.
- Roberts, M. R., & Paul, N. D. (2006). Seduced by the dark side: Integrating molecular and ecological perspectives on the influence of light on plant defence against pests and pathogens. *The New Phytologist*, 170(4), 677–699.
- Roden, L. C., & Ingle, R. A. (2009). Lights, rhythms, infection: The role of light and the circadian clock in determining the outcome of plant-pathogen interactions. *Plant Cell*, 21(9), 2546–2552.
- Rodriguez-Herva, J. J., Gonzalez-Melendi, P., Cuartas-Lanza, R., Antunez-Lamas, M., Rio-Alvarez, I., Li, Z., ... Lopez-Solanilla, E. (2012). A bacterial cysteine protease effector protein interferes with photosynthesis to suppress plant innate immune responses. *Cellular Microbiology*, 14(5), 669–681.
- Rusaczonok, A., Czarnocka, W., Kacprzak, S., Witonm, D., Slesak, I., ... Karpinski, S. (2015). Role of phytochromes A and B in the regulation of cell death and acclimatory responses to UV stress in *Arabidopsis thaliana*. *Journal of Experimental Botany*, 66(21), 6679–6695.
- Sangwan, V., Orvar, B. L., Beyerly, J., Hirt, H., & Dhindsa, R. S. (2002). Opposite changes in membrane fluidity mimic cold and heat stress activation of distinct plant MAP kinase pathways. *The Plant Journal*, 31(5), 629–638.
- Sato, R., Kono, M., Harada, K., Ohta, H., Takaichi, S., & Masuda, S. (2017). Fluctuating-light-acclimation protein1, conserved in oxygenic phototrophs, regulates H<sup>+</sup> homeostasis and non-photochemical quenching in chloroplasts. *Plant & Cell Physiology*, 58(10), 1622–1630.
- Schneider, T., Bolger, A., Zeier, J., Preiskowski, S., Benes, V., Trenkamp, S., ... Matsubara, S. (2019). Fluctuating light interacts with time of day and leaf development stage to reprogram gene expression. *Plant Physiology*, 179(4), 1632–1657.
- Schreiber, U., Hormann, H., Asada, K., & Neubauer, C. (1995). O<sub>2</sub>-dependent electron flow in spinach chloroplasts: Properties and possible regulation of the Mehler-ascorbate peroxidase cycle. *Photosynthesis*, 2, 813–818.
- Serrano, I., Audran, C., & Rivas, S. (2016). Chloroplasts at work during plant innate immunity. *Journal of Experimental Botany*, 67(13), 3845–3854.
- Sessa, G., Carabelli, M., Possenti, M., Morelli, G., & Ruberti, I. (2018). Multiple Pathways in the Control of the Shade Avoidance Response. *Plants*, 7(4), 102.
- Shamrai, S. N. (2014). Plant immune system: Basal immunity. *Cytology and Genetics*, 48, 258–271.
- Shikanai, T. (2016). Chloroplast NDH: A different enzyme with a structure similar to that of respiratory NADH dehydrogenase. *Biochimica et Biophysica Acta*, 1857(7), 1015–1022.
- Shin, D. H., Choi, M., Kim, K., Bang, G., Cho, M., Choi, S. B., ... Park, Y. I. (2013). HY5 regulates anthocyanin biosynthesis by inducing the transcriptional activation of the MYB75/PAP1 transcription factor in Arabidopsis. *FEBS Letters*, 587(10), 1543–1547.
- Silva, C. S., Nayak, A., Lai, X., Hutin, S., Hugouvieux, V., Jung, J. H., ... Zubieta, C. (2020). Molecular mechanisms of Evening Complex activity in Arabidopsis. *Proceedings of the National Academy of Sciences of the United States of America*, 117(12), 6901–6909.
- Soitamo, A. J., Piippo, M., Allahverdiyeva, Y., Battchikova, N., & Aro, E. M. (2008). Light has a specific role in modulating Arabidopsis gene expression at low temperature. *BMC Plant Biology*, 8, 13.
- Somers, D. E., Devlin, P. F., & Kay, S. A. (1998). Phytochromes and cryptochromes in the entrainment of the Arabidopsis circadian clock. *Science*, 282(5393), 1488–1490.
- Song, J., Liu, Q., Hu, B., & Wu, W. (2017). Photoreceptor PhyB Involved in Arabidopsis Temperature Perception and Heat-Tolerance Formation. *International Journal of Molecular Sciences*, 18(6), 1194.
- Song, L., Jiang, Y., Zhao, H., & Hou, M. (2012). Acquired thermotolerance in plants. *Plant Cell, Tissue and Organ Culture*, 111, 265–276.
- Song, Y. H., Estrada, D. A., Johnson, R. S., Kim, S. K., Lee, S. Y., MacCoss, M. J., & Imaizumi, T. (2014). Distinct roles of FKF1, Gigantha, and Zeitelu proteins in the regulation of Constans stability in Arabidopsis photoperiodic flowering. *Proceedings of the National Academy of Sciences of the United States of America*, 111(49), 17672–17677.
- Sonoike, K. (1996). Photoinhibition of photosystem I: Its physiological significance in the chilling sensitivity of plants. *Plant & Cell Physiology*, 37(3), 239–247.
- Sonoike, K., & Terashima, I. (1994). Mechanism of photosystem-I photoinhibition in leaves of *Cucumis sativus* L. *Planta*, 194, 287–293.
- Takahashi, S., & Badger, M. R. (2011). Photoprotection in plants: A new light on photosystem II damage. *Trends in Plant Science*, 16(1), 53–60.
- Takahashi, S., Milward, S. E., Yamori, W., Evans, J. R., Hillier, W., & Badger, M. R. (2010). The solar action spectrum of photosystem II damage. *Plant Physiology*, 153(3), 988–993.
- Takahashi, S., & Murata, N. (2008). How do environmental stresses accelerate photoinhibition? *Trends in Plant Science*, 13(4), 178–182.
- Takase, T., Nishiyama, Y., Tanihigashi, H., Ogura, Y., Miyazaki, Y., Yamada, Y., & Kiyosue, T. (2011). LOV KELCH PROTEIN2 and ZEITLUPE repress Arabidopsis photoperiodic flowering under non-inductive conditions, dependent on FLAVIN-BINDING KELCH REPEAT F-BOX1. *The Plant Journal*, 67(4), 608–621.
- Tallman, G. (2004). Are diurnal patterns of stomatal movement the result of alternating metabolism of endogenous guard cell ABA and accumulation of ABA delivered to the apoplast around guard cells by transpiration? *Journal of Experimental Botany*, 55(405), 1963–1976.
- Taylor, B. L., & Zhulin, I. B. (1999). PAS domains: Internal sensors of oxygen, redox potential, and light. *Microbiology and Molecular Biology Reviews*, 63(2), 479–506.
- Thomashow, M. F. (1999). Plant cold acclimation: Freezing tolerance genes and regulatory mechanisms. *Annual Review of Plant Physiology and Plant Molecular Biology*, 50, 571–599.
- Thomashow, M. F. (2010). Molecular basis of plant cold acclimation: Insights gained from studying the CBF cold response pathway. *Plant Physiology*, 154(2), 571–577.
- Tissot, N., & Ulm, R. (2020). Cryptochrome-mediated blue-light signalling modulates UVR8 photoreceptor activity and contributes to UV-B tolerance in Arabidopsis. *Nature Communications*, 11(1), 1323.
- Torres, M. A. (2010). ROS in biotic interactions. *Physiologia Plantarum*, 138(4), 414–429.
- Trotta, A., Rahikainen, M., Konert, G., Finazzi, G., & Kangasjärvi, S. (2014). Signalling crosstalk in light stress and immune reactions in plants. *Philosophical Transactions of the Royal Society of London. Series B, Biological Sciences*, 369(1640), 20130235.
- Tsuda, K., & Katagiri, F. (2010). Comparing signaling mechanisms engaged in pattern-triggered and effector-triggered immunity. *Current Opinion in Plant Biology*, 13, 459–465.
- Verhage, A., van Wees, S. C., & Pieterse, C. M. (2010). Plant immunity: It's the hormones talking, but what do they say? *Plant Physiology*, 154(2), 536–540.
- Walters, R. G. (2005). Towards an understanding of photosynthetic acclimation. *Journal of Experimental Botany*, 56(411), 435–447.
- Wang, F., Guo, Z., Li, H., Wang, M., Onac, E., Zhou, J., ... Zhou, Y. (2016). Phytochrome A and B function antagonistically to regulate cold tolerance via abscisic acid-dependent jasmonate signaling. *Plant Physiology*, 170(1), 459–471.
- Wang, F. F., Lian, H. L., Kang, C. Y., & Yang, H. Q. (2010). Phytochrome B is involved in mediating red light-induced stomatal opening in *Arabidopsis thaliana*. *Molecular Plant*, 3(1), 246–259.
- Wang, Q., & Lin, C. (2020). Mechanisms of cryptochrome-mediated photoresponses in plants. *Annual Review of Plant Biology*, 71, 103–129.
- Wang, X., Wang, Q., Han, Y.-J., Liu, Q., Gu, L., Yang, Z., ... Lin, C. (2017). A CRY-BIC negative feedback circuitry regulating blue light sensitivity of Arabidopsis. *The Plant Journal*, 92(3), 426–436.

- Waters, M. T., & Langdale, J. A. (2009). The making of a chloroplast. *The EMBO Journal*, 28(19), 2861–2873.
- Weston, E., Thorogoot, K., Vinti, G., & Lopez-Juez, E. (2000). Light quality controls leaf-cell and chloroplast development in *Arabidopsis thaliana* wild-type and blue-light-perception mutants. *Planta*, 211(6), 807–815.
- Wu L., Yang H.-Q. (2010). CRYPTOCHROME 1 is implicated in promoting R protein-mediated plant resistance to *Pseudomonas syringae* in *Arabidopsis*. *Molecular Plant*, 3(3), 539–548. <http://dx.doi.org/10.1093/mp/ssp107>.
- Yamamoto, Y. (2016). Quality control of photosystem II: The mechanisms for avoidance and tolerance of light and heat stresses are closely linked to membrane fluidity of the thylakoids. *Frontiers in Plant Science*, 7, 1136.
- Yang, C., & Li, L. (2017). Hormonal regulation in shade avoidance. *Frontiers in Plant Science*, 8, 1527.
- Yang, Y., Zhang, L., Chen, P., Liang, T., Li, X., & Liu, H. (2020). UV-B photoreceptor UVR8 interacts with MYB73/MYB77 to regulate auxin responses and lateral root development. *The EMBO Journal*, 39(2), e101928.
- Yang, Y. X., Wang, M. M., Yin, Y. L., Onac, E., Zhou, G. F., Peng, S., ... Zhou, Y. H. (2015). RNA-seq analysis reveals the role of red light in resistance against *Pseudomonas syringae* pv. tomato DC3000 in tomato plants. *BMC Genomics*, 16, 120.
- Yin, R. (2017). Cooling down thermomorphogenesis by UV-B signaling. *Trends in Plant Science*, 22(6), 447–449.
- Yoshinaga, N., Alborn, H. T., Nakanishi, T., Suckling, D. M., Nishida, R., Tumlinson, J. H., & Mori, N. (2010). Fatty acid-amino acid conjugates diversification in lepidopteran caterpillars. *Journal of Chemical Ecology*, 36(3), 319–325.
- Zeier, J., Pink, B., Mueller, M. J., & Berger, S. (2004). Light conditions influence specific defence responses in incompatible plant-pathogen interactions: Uncoupling systemic resistance from salicylic acid and PR1 accumulation. *Planta*, 219(4), 673–683.
- Zhang, M., Chiang, Y. H., Toruno, T. Y., Lee, D., Ma, M., Liang, X., ... Coaker, G. (2018). The MAP4 kinase SIK1 ensures robust extracellular ROS burst and antibacterial immunity in plants. *Cell Host & Microbe*, 24(3), 379–391 e375.
- Zhang, Y., Zhang, A., Li, X., & Lu, C. (2020). The role of chloroplast gene expression in plant responses to environmental stress. *International Journal of Molecular Sciences*, 21(17), E6082.

## SUPPORTING INFORMATION

Additional supporting information may be found online in the Supporting Information section at the end of this article.

**How to cite this article:** Roeber VM, Bajaj I, Rohde M, Schmölling T, Cortleven A. Light acts as a stressor and influences abiotic and biotic stress responses in plants. *Plant Cell Environ*. 2021;44:645–664. <https://doi.org/10.1111/pce.13948>