

Light-weight 3D LADAR System for Construction Robotic Operations

Yong K. Cho¹ and Diego Martinez²

¹Assistant Professor (corresponding author), Construction Engineering and Management Division, Charles Durham School of Architectural Engineering and Construction, College of Engineering, University of Nebraska-Lincoln, 1110 S. 67th St. Peter Kiewit Institute (PKI) 104C, Omaha, NE 69182; PH(402)554-3277; FAX (402)554- 3850; email: ycho2@unl.edu

²Graduate Research Assistant, Computer Engineering and Electronics Department, College of Engineering, University of Nebraska-Lincoln, 1110 S. 67th St. Peter Kiewit Institute (PKI) 118A, Omaha, NE 69182; PH(402)554-3277; FAX (402)554- 3850; email: dmartinez@mail.unomaha.edu

Abstract

This paper presents an on-going research on a light-weight 3-dimensional (3D) laser distance and ranging (LADAR) system development at the Peter Kiewit Institute (PKI) in University of Nebraska–Lincoln. The developed LADAR can be readily applied to several construction applications related to automated or robotic tasks, mobile robot navigation, reverse engineering, quality assurance/control, schedule control, and safety. A design concept of a LADAR system on a dynamic mobile platform is introduced which is especially designed for precise construction robotic operations such as welding, bolting, and connecting materials. Barriers for rapid 3D graphical workspace visualization at construction sites are discussed as well. The preliminary laboratory test results demonstrate that the 3D LADAR scanner developed in this study provides reliable scanned data. Unlike most of the heavy and bulky commercial LADAR products, the developed economical LADAR system can be used on mobile platforms and manipulators or confined area scanning applications due to its small size and light-weight characteristics.

Keywords: 3D scanner, LADAR, laser, visualization, robotics, construction automation, error

1 Introduction

In construction, significant time is spent every day on job sites to identify and track construction materials and equipment and to capture, align and compare field measured data to planned data to detect defects and improve quality control. This requires rapid recognition and accurate measurement of objects in the field so that timely, on-site decisions can be made. Especially 3-dimensional (3D) graphical visualization of the site can help to optimize material tracking and automated equipment control, significantly improve safety, and enhance a remote operator's spatial perception of the workspace. FIATECH (2008) envisions that construction sites will become more 'intelligent and integrated' as materials and equipment, and people become elements of a fully sensed and monitored work environment.

Although studies in several fields have proven that 3D visualization of the work environment can significantly enhance construction defect control, material tracking, schedule control, and automated equipment control, unstructured work areas like construction sites are difficult to visualize graphically because they contain highly unpredictable activities and change rapidly. Automated construction site operation, e.g., robotic operation, requires real-time or near real-time information about the surrounding work environment, which further complicates graphical modeling and updating. Especially, solid material handling tasks in construction require not only rapid visualization of unstructured workspace but highly accurate position data for safe and secure physical contact between a target object and an end-effector of automated mobile equipment or robots.

This paper discusses the current 3D visualization technologies and their limitations for construction applications and introduces a 3D LADAR scanner being developed for robotic applications in construction sites.

2 Current 3D Visualization Technologies

This section discusses applicability of current 3D visualization technologies at construction sites.

2.1 Machine Vision systems

CCD camera-based machine vision systems are useful to visualize a workspace under well controlled environment. However, they may not perform very well to get an accurate pose of the target objects for heavy construction applications which require long distance position measurements. Furthermore, as with any vision application, consistent lighting is critical to obtain accurate workspace information. It explains why most of the robotic applications with a vision system are mainly limited to indoor applications, including automotive, electronics, packaging, machining, and food. Getting high position data accuracy using a vision system at unstructured indoor and outdoor construction sites is impractical due to extreme or inconsistent daylight conditions, bad weather, and clouds of dust. In that case, a distance sensor, such as a laser or an ultrasonic sensor, might better enable the robot to draw a bead on the target (Sprovieri, 2007).

2.2 Flash LADAR Research

An emerging range sensing technology, called 3D range camera or Flash LADAR, is based on the time-of-flight measurement principle which uses light. The estimated accuracy in Z axis with one pixel of the Flash LADAR (SR4000) is +/- 1cm with up to 54 frame rate (FPS) under well controlled indoor lighting conditions. SR4000's measurement distance ranges from 0.3 to 5 meters (Mesa Imaging, 2008). While LADAR/LIDARs need to scan objects or scenes to collect point data sets (point clouds), flash LADAR systems do not require a scanning pointing mechanism. Compared to commercially available LADAR/LIDARs, the advantages of using a flash LADAR are that it is smaller, inexpensive, and forms 3D images in real time. The disadvantages include a limited view size and lower accuracy and resolution. In addition, SR4000, the latest version of Flash LADAR, is designed mainly for indoor applications. The noise level makes it impossible to work in direct sunlight.

2.3 ZScanner

Z Corporation (2008) has developed the first hand-held self-positioning scanner on the market. This digital scanner uses the subject part being scanned to establish its spatial reference eliminating the need for fixed-position tripods, bulky mechanical arms or external positioning devices that make hard-to-reach surfaces to scan. Uniquely part-referenced, the system allows the target object's moving during scanning and a real-time image of the surface being scanned can be seen. It captures data in one continuous scan rather than in numerous shots from fixed positions, eliminating hours of post-processing time. Scanning resolution and accuracy are within 40 μ m (microns) and detects changes in surface height down to 50 μ m. The scanner supports STL and TXT file formats. To position itself, the ZScanner uses reflective targets, which are applied to the surface of the part to be scanned and/or the area adjacent to the part. These reflective targets can be quickly and randomly applied. During the scanning process, the ZScanner locates and captures the reflective positioning targets in real time. Their respective positions are calculated in reference to the scanner and then recorded. The targets on the object create patterns recognizable by the ZScanner. The patterns defined by the positioning features do not repeat because the targets are applied randomly. This pattern recognition allows the scanner to position itself in the same way that GPS devices use known satellites to establish their position on Earth (Z Corporation, 2008).

In this study, the ZScanner is tested for scanning a fake duck model on which many reflective dots (targets) are attached. The scanner models a 3D graphical duck in real time while it is scanning a duck model (Figure 1).

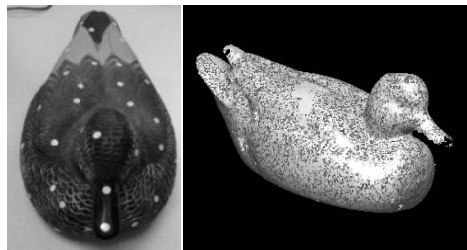

Figure 1. Example duck model scanned with ZScanner

The limitation of this scanner is its short measurement range (about less than 1 meter). Also the scanner cannot model a complex surface well like a human ear if it cannot have a clear shot from the both cameras. In this case, the camera sees just with one “eye” and not with the other, which models an incomplete shape. The example of this problem is shown in Figure 2.

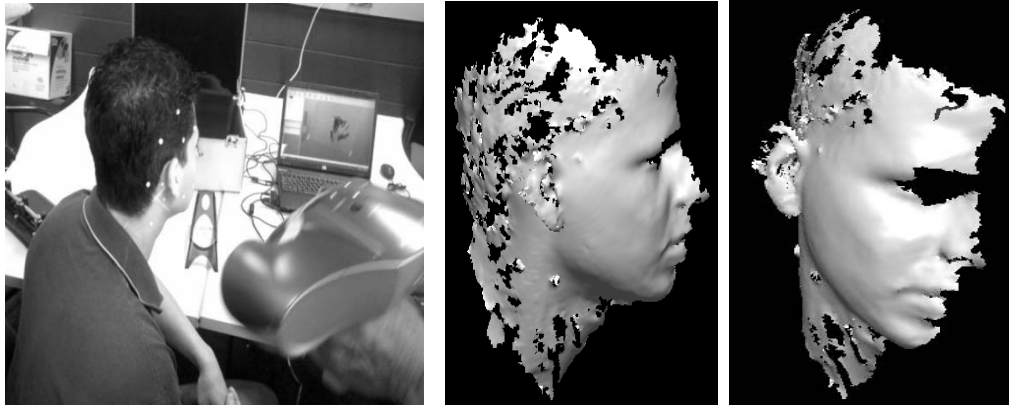

Figure 2. Example of incomplete model with complex surfaces, e.g., ear

2. 4 LADAR/LIDAR (3D Scanning) Technologies

Laser distance and ranging (LADAR) or light detection and ranging (LIDAR) technology has been used to create 3D as-built models of structures and scenes for quality control, surveying, mapping, reverse engineering, terrain characterization, autonomous vehicle navigation, and vehicle-based safety and warning systems (Cheok et. al. 2005). Time-of-flight (TOF) or phase shift measurement is generally used in these laser scanning systems which produce a data set that consists of multiple X,Y,Z, and I values, where I represents the intensity of the reflected laser return. The points in a data set are referred to as a point cloud. State-of-the art LADAR technology, e.g., Leica ScanStation and RIEGL LMS-Z390i, provides about 4mm distance accuracy and 6mm position accuracy up to 50 meters for a single measurement. The error becomes greater when point clouds are obtained from a scene. Accuracy depends on a number of additional factors beyond the underlying sensor accuracy, including measurement goal type, object size, surface orientation, and even surface material, e.g, darkness, reflectivity (Akinci et al. 2006).

2.4.1 Time-of-Flight (or Pulsed) vs. Phase Shift

The time-of-flight scanner has a capture rate of around 4,000-6,000 points per second and is able to capture between 130-200m diameter of data depending on type and reflectivity of the material/object being scanned. Unlike the time-of-flight scanner, the phase shift scanner's data capture rate is very fast, e.g., up to 625,000 points per second for Z+F laser scanner™, thus it produces high point cloud density in a short period. However, the phase shift scanner acquires shorter distance measurement (around 40m-80m). Leica ScanStation2™ and RIEGL™ are good examples of time-of-flight scanners; and Faro™ and Leica HDS 6000™ are good examples of phase shift scanners.

3. 3D LADAR Prototype development

LADAR/LIDAR system is superior to machine vision and flash LADAR under aforementioned unfavorable working condition. However, LADAR/LIDAR technology still has limitations to be applied to some automated construction applications. Most of the LADAR commercial-off-the-shelf products are difficult to apply as they are for the dynamic robotic operation in construction without reducing substantial amount of size and weight. They are too heavy and expensive to be mounted on dynamic robotic systems. For example, Leica's Scanstation with a battery pack weighs about 30 kgs. To resolve this issue, this research develops a small and light LADAR system consisting of a 2D line laser and a pan and tilt unit (PTU) which can be mounted on mobile platforms or used confined area scanning applications from an articulated robotic arm.

The 2D line laser as a main component for the LADAR system is a precise spinning mirror assembly that deflects a laser beam 90 degrees, sweeping it through a full 2D circle as the mirror rotates. When coupled with a pan and tilt unit, then, the 2D line laser creates a light-weight and economical 3D scanner. It is important to consider key factors when selecting a line laser according to application goal type. The key factors include resolution, accuracy, repeatability, distance range, and indoor or outdoor use.

In this research, the custom-built LADAR scanner provides point clouds up to 200K points per second from a scene within 8mm accuracy for about 15m distance. The design concept of the 3D LADAR scanner developed in this research can be applied to several different applications by replacing a line laser to meet application's requirement. For example, industrial welding/ bolting robots and medical scanning applications may need high resolution, accuracy, and repeatability for indoor use. A short distance range may be acceptable. The applications for cranes and construction site safety primarily need a long-range line laser designed for outdoor conditions.

To have target-focused measurements from a scene, a single-axis laser rangefinder is coupled with the 3D LADAR system. For the convenience of laboratory experiment and software development, the whole sensor and control units are mounted on a custom-built mobile cart which can be also simulated as a mobile construction platform. To scan objects which are in blind spots, or need multiple surface scans, the 3D LADAR system is mounted on a rotating steel arm controlled by an accurate actuator which can simulate a robot arm. Based on the current laser mounting configuration, multiple Degree-Of-Freedom (DOF) kinematics is solved to obtain x-y-z point values for both the LADAR and a laser rangefinder systems (Figure 3). In analyzing the kinematics for the LADAR system, the Denavit-Hartenberg (D-H) parameters (Craig, 1986) is applied. The D-H parameters describe the positions of links and joints unambiguously. Each link and joint pair can be described as a coordinate transformation from the previous coordinates system to the next coordinate system. Figure 4 shows the point clouds of the scanned room area with the developed 3D LADAR system.

3.1 Noise reduction

Parameters affecting the noise level are sampling rate, ambient light and temperature, surface orientation of the target, target surface properties including color, i.e., gray level, and material types, mixed pixels, and poor visibility conditions (Akinci et al. 2006). Ambient light and temperature did not significantly affect the range accuracy but the accuracy was turned out to be very sensitive to surface orientation, reflectivity and color (gray level) in this research. Based on the target gray level, an amplitude rate needs to be accordingly adjusted to get better results. The amplitude rate determines the intensity or brightness of light. The test results show that the amplitude rate significantly affects the noisy level when it was adjusted in advance according to target's surface color. Figure 5 shows the test results using the KUKA testbed. The KUKA robot is used to simulate welding and pick and place tasks based on the 3D scanned workspace information to evaluate the accuracy and efficiency of the developed LADAR system.

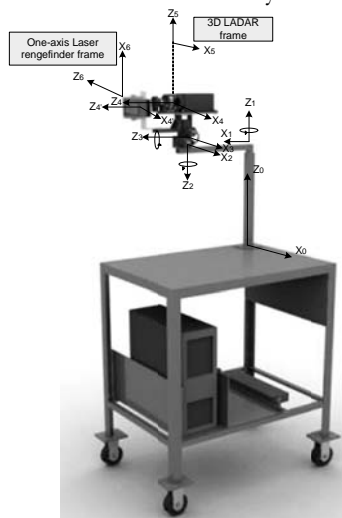

Figure 3. Prototype LADAR system on a cart



Figure 4. Photo image (top) and scanned point clouds image (bottom) for a lab meeting area

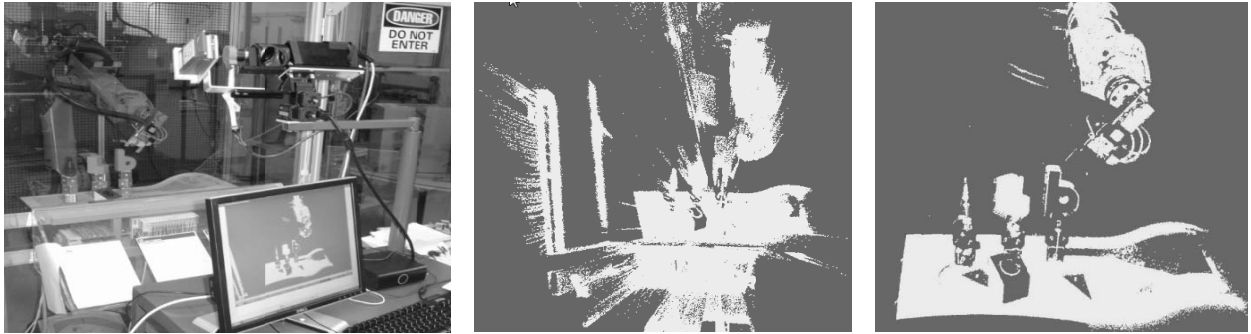

Figure 5. (a) KUKA robot testbed with targets

(b) Noisy LADAR point clouds scanned without range guidance & without amplitude adjustment

(c) Target-focused point clouds and reduced noises with amplitude adjustment

3.2 Current Research Efforts

As an on-going research, the research team currently focuses on the following two tasks:

3.2.1 Dynamic multi-scans from a robotic arm

Two or more multi-scans from different views can be theoretically achieved when a scanner is mounted on a robotic arm and the scanned scenes can be merged while scanning without losing track of the scanner's position in reference to the target. In reality, however, a robot arm or manipulator generates position errors due to accumulated feedback errors of the rotary and prismatic joint sensors, and lost actuator motion due to backlash. Presence of payloads, kinematic and dynamic states influence error attributes as well (Cho et al. 2004). The research team currently investigates how error attributes created from rotary actuators used for rotating arm and the pan and tilt unit influence theoretical kinematics solutions. Then, the identified error attributes are used to calibrate the LADAR position estimation.

3.2.2 Automatic target detection and registration

Recognizing objects by establishing point correspondences between a CAD model and a scene data set is not a new idea (Grimson, 1990). However, it is still not an easy task especially when the scene data set contains a large number of noisy point measurements. It is also a challenging task if a solid object needs to be automatically registered to that noisy scene data set. Currently, this registration process is manually done. This research is currently developing an algorithm which can estimate and predict surfaces from the noisy point measurements by rearranging the points for more effective target detection and registration processes. Figure 6 briefly illustrates this process.

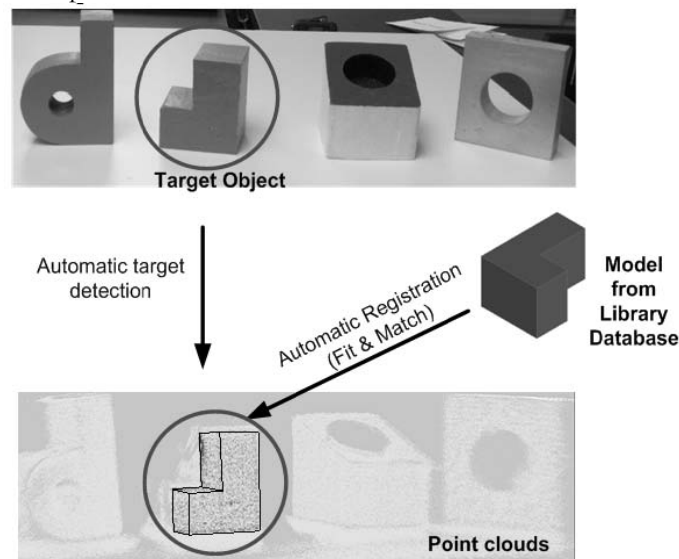

Figure 6. Automatic target detection and registration process

While the research team is considering several different approaches to register an object into the 3D space, the LADAR image processing method is introduced here.

Edge detection

To automate the target object recognition, an intensity LADAR image is measured and analyzed to automatically find target object's boundary lines (Figure 7).

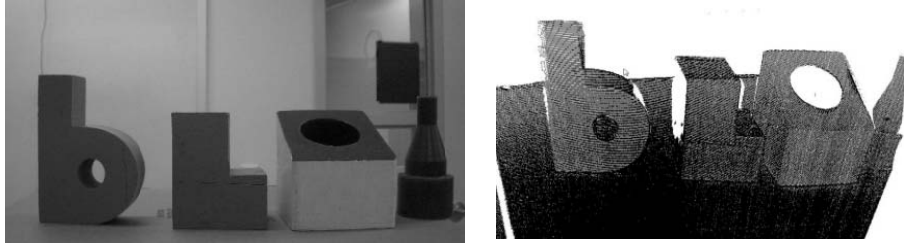

Figure 7. Target objects (left) and binary edge detection of scanned point cloud image (right).

3D model registration

To fit a 3D CAD model to the LADAR image, the model-based pose iteration process using the Iterative Inverse Perspective Matching algorithm developed by Wunsch and Hirzinger is being considered (1996). As there is no distance metric relating 3D point coordinates to 2D image coordinates, the 3D model will be projected into the LADAR image plane and to match features in image coordinates. The 2D to 3D registration problem can be formulated as follows (Wunsch et al. 1996):

$$E(\mathbf{R}, \mathbf{t}) = \sum_{p \in P} \left(d(\text{CLP}(p, \mathbf{R}\mathbf{x} + \mathbf{t})) \right)^2$$

Where, \mathbf{R} is a 3x3 rotation matrix and \mathbf{t} is a translation vector.

$$E(\mathbf{R}, \mathbf{t}) = \sum_{i=0}^N \varrho(y_i - (\mathbf{R}x_i + \mathbf{t}))$$

$$\varrho(x) = \begin{cases} 0.5x^2, & \text{if } |x| < a \\ a|x| - 0.5a^2, & \text{otherwise} \end{cases}$$

Combing the computation of closest points with a robust pose estimator leads to the following iterative registration procedure:

```

for k=0,1, ..... do
     $[x^k, y^k] = \text{CLP}(P, X^k)$ 
     $[\mathbf{R}, \mathbf{t}] = \text{register}(x^k, y^k, w^k)$ 
     $X^{k+1} = \mathbf{R} X^k + \mathbf{t}$ 
     $W^k = \text{ComputeWeight}$ 
endfor
    
```

Figure 8 illustrates the fitting and matching process using Iterative Inverse Perspective Matching algorithm (Chen and Medioni, 1992; Besl and McKay, 1992; and Wunsch and Hirzinger, 1996).

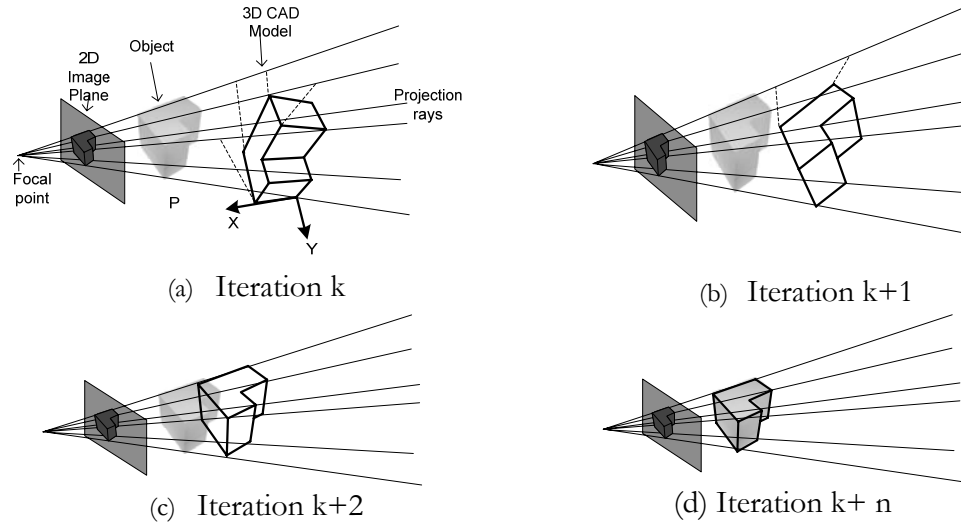

Figure 8. Establishing correspondences between an image and a 3D model based on closest points.

4. Conclusions

A 3D LADAR scanner development research is introduced in this paper. The developed small and light-weight scanner is readily applicable for several dynamic construction automation applications such as robotic manipulator control, robotic inspection, crane application, road profiling, and confined space scanning, where many of commercial scanners have not been well utilized because of their bulky and heavy mechanisms, and expensive purchasing cost. As a major contribution of this research, such a small LADAR system developed in this study can be a useful component to make more “intelligent and integrated” construction sites by providing a highly accurate rapid 3D workspace for automated construction equipment or robotic operations. As an on-going research, the research team continues to conduct the tasks including dynamic multi-scan and registration, rapid data process for real-time robotic operations, error modeling, 3D model registration algorithm development, and mobilization for construction site navigation.

References

- [1] Akinci, B., Boukamp, B., Gordon, C., Huber, D., Lyons, C., and Park, K. (2006). “A Formalism for Utilization of Sensor Systems and Integrated Project Models for Active Construction Quality Control,” *Automation in Construction*, Vol. 15, No. 2, February, pp. 124-138.
- [2] Besl, P., and McKay, D. (1992) “A method for registration of 3-D shapes,” *IEEE Trans. Pattern Analysis and Machine Intelligence*, 14(2):239-256, February.
- [3] Chen, Y. and Medioni, G. (1992). "Object Modeling by Registration of Multiple Range Images." *Image and Vision Computing*, 10(3), 145-155.
- [4] Cho, Y., Haas, C., Sreenivasan, S., and Liapi, K. (2004). “Error Analysis and Correction for Large Scale Manipulators in Construction,” *the ASCE Journal of Construction Engineering and Management* Vol. 130, (1), pp.50-58.
- [5] Craig, J. (1986). *Introduction to Robotics: Mechanics & Control*. Addison-Wesley.
- [6] FIATECH (2008). "Capital Projects Technology Roadmap: Element 4 Tactical Plan, Intelligent and Automated Construction Job Site (IACJS), <www.fiatech.org/projects/roadmap/cptri.htm> (Dec.11, 2008).
- [7] Gilsinn, D., Cheok, G., Witzgall, C., Lytle, A. (2005), “Construction Object Identification from LADAR scans: An Experimental Study Using I-beams,” *NIST Integragency Report*.
- [8] Grimson, W. (1990). *Object recognition by computer: The Role of Geometric Constraints*, MIT Press, Cambridge, MA, 1990.
- [9] Grimson, W. (1990). *Object recognition by computer: The Role of Geometric Constraints*, MIT Press, Cambridge, MA, 1990.

- [10] Johnson, A. and Hebert, M. (1998). Surface matching for object recognition in complex three-dimensional scenes. *Image and vision computing : Projection-based transforms*, vol.16, n9-10(20 ref.),pp.635-651.
- [11] Mesa Imaging (2008). SwissRanger™ SR4000, <<http://www.mesa-imaging.ch/prodview4k.php>>, (Dec. 8, 2008).
- [12] Sprovieri, J. (2007). "Vision Systems Help Robots Find, Assemble Parts," *Assembly Magazine*, issued on April 1, 2004, www.assemblymag.com/CDA/Archives/bc0975c53f5c9010VgnVCM100000f932a8c0, (September 2007).
- [13] Wunsch, P. and Hirzinger, G. (1996). "Registration of CAD-models to images by iterative inverse perspective matching," in *Proc. 13th Int. Conf. on Pattern Recognition*, Vienna, Austria, pp. 78-83.
- [14] Z Corporation (2008). ZScanner, <<http://zscanner.com> >, (Dec. 8, 2008).
- [15] Zheng, Q., Der, S., and Chellappa, R. (2001). "Model-based Target Recognition in Pulsed Ladar Imagery," *IEEE Transaction on Image processing*, vol. 10, No.4, April, pp. 565-572.