

# Limit Cycle Models for Circadian Rhythms Based on Transcriptional Regulation in *Drosophila* and *Neurospora*

Jean-Christophe Leloup, Didier Gonze, and Albert Goldbeter<sup>1</sup>

Faculté des Sciences, Université Libre de Bruxelles, Campus Plaine, C.P. 231, B-1050 Brussels, Belgium

**Abstract** We examine theoretical models for circadian oscillations based on transcriptional regulation in *Drosophila* and *Neurospora*. For *Drosophila*, the molecular model is based on the negative feedback exerted on the expression of the *per* and *tim* genes by the complex formed between the PER and TIM proteins. For *Neurospora*, similarly, the model relies on the feedback exerted on the expression of the *frq* gene by its protein product FRQ. In both models, sustained rhythmic variations in protein and mRNA levels occur in continuous darkness, in the form of limit cycle oscillations. The effect of light on circadian rhythms is taken into account in the models by considering that it triggers degradation of the TIM protein in *Drosophila*, and *frq* transcription in *Neurospora*. When incorporating the control exerted by light at the molecular level, we show that the models can account for the entrainment of circadian rhythms by light-dark cycles and for the damping of the oscillations in constant light, though such damping occurs more readily in the *Drosophila* model. The models account for the phase shifts induced by light pulses and allow the construction of phase response curves. These compare well with experimental results obtained in *Drosophila*. The model for *Drosophila* shows that when applied at the appropriate phase, light pulses of appropriate duration and magnitude can permanently or transiently suppress circadian rhythmicity. We investigate the effects of the magnitude of light-induced changes on oscillatory behavior. Finally, we discuss the common and distinctive features of circadian oscillations in the two organisms.

**Key words** circadian clock, oscillations, PER, TIM, FRQ, model

Theoretical models have long proved useful in clarifying the conditions in which periodic phenomena arise in regulated biological systems (Winfree, 1980; Goldbeter, 1996). Most models proposed so far pertain to ultradian biochemical oscillations, characterized by periods ranging from seconds to minutes, and interpret such periodic behavior in terms of limit cycle oscillations. The view that circadian rhythms represent limit cycle oscillators dates back to some four decades ago (Kalmus and Wigglesworth, 1960; Pavlidis, 1973; Winfree, 1980), before the development of studies of ultradian rhythms. Mathematical models

for circadian rhythms were first of an abstract nature and were borrowed from the physical literature, as exemplified by the use of the van der Pol oscillator as an analog for circadian oscillations (Wever, 1972). This approach is still used to study the effect of light on the human circadian system (Jewett and Kronauer, 1998).

The study of models for oscillations more directly based on biochemical processes represents a complementary line of research. One of the first molecular models for biochemical rhythms, anticipating many experimental findings on circadian clock mechanisms that were later obtained, was proposed for oscillations

1. To whom all correspondence should be addressed.

resulting from negative feedback on gene expression (Goodwin, 1965). This model was subsequently used to examine properties of circadian rhythms such as phase shifting by light pulses (Drescher et al., 1982) or temperature compensation (Ruoff and Rensing, 1996).

During the past decade, thanks to genetic and biochemical studies, remarkable advances have clarified the feedback processes that control the molecular mechanism of circadian clocks, particularly in *Drosophila* (Rosbash, 1995), *Neurospora* (Crosthwaite et al., 1997), and mammals (Dunlap, 1998). Given the increasing availability of experimental data, more detailed theoretical models can now be considered for circadian rhythms. Such models based on transcriptional regulation have been proposed for circadian oscillations of the products of the *per* and *tim* genes in *Drosophila* (Goldbeter, 1995; Leloup and Goldbeter, 1998).

The purpose of the present article is to examine limit cycle models for circadian oscillations based on the experimental observations gathered on the molecular mechanisms of circadian rhythms in *Drosophila* and *Neurospora*. We show that the minimal form of the molecular model previously proposed for circadian oscillations in *Drosophila* (Goldbeter, 1995, 1996) can be used, with a few minor modifications, to account for circadian oscillations in *Neurospora*. Beyond differences in kinetic details, the transcriptional feedback mechanism that lies at the core of the oscillations is the same as in the Goodwin model, which was recently used to study circadian rhythms in *Neurospora* (Ruoff et al., 1999).

Incorporating the effect of light on the circadian mechanism allows the comparison of theoretical predictions with experimental data in regard to several properties, including oscillations in continuous darkness or light, entrainment by light-dark cycles, and phase resetting by light pulses. We discuss the usefulness of limit cycle models based on molecular mechanisms for studying the origin and the properties of circadian rhythms.

## MODELS FOR CIRCADIAN OSCILLATIONS IN *DROSOPHILA* AND *NEUROSPORA*

Experimental observations indicate that a similar genetic control mechanism underlies circadian rhythm generation in both *Drosophila* and *Neurospora*.

In each case, it appears that circadian oscillations originate from the negative autoregulation of gene expression (Dunlap, 1998; Rosbash, 1995; Crosthwaite et al., 1997). Thus, in *Drosophila*, as schematized in Fig. 1 (left part), a complex formed by the proteins PER and TIM, products of the *per* and *tim* genes, migrates to the nucleus where it represses the transcription of these genes; light controls the circadian system by inducing the degradation of TIM (Zeng et al., 1996). Similarly, in *Neurospora* (see Fig. 1, right part), a protein known as FRQ enters the nucleus where it represses the transcription of its gene *frq* (Crosthwaite et al., 1997). Here, in contrast, light controls the circadian system by inducing the transcription of *frq* (Crosthwaite et al., 1995). The theoretical models presented below for circadian oscillations in *Drosophila* and *Neurospora* incorporate the negative autoregulatory feedback loops involving, respectively, the PER-TIM complex and FRQ, as well as the specific effects of light in these two systems.

### Model for Circadian Rhythms in *Drosophila*

The first model studied for circadian oscillations in *Drosophila* (Goldbeter, 1995, 1996) was based on the sole negative regulation exerted by PER on the expression of the *per* gene. The model also incorporated the multiple phosphorylation of PER. This model was later extended to incorporate the role of the TIM protein, which forms a complex with PER (Leloup and Goldbeter, 1998). Whereas the dynamic behavior of the former model was described by a set of 5 kinetic equations, the behavior of the extended model schematized in Fig. 1 is governed by a set of 10 kinetic equations describing the time evolution of the mRNAs of *per* and *tim*, as well as the various phosphorylated or nonphosphorylated forms of PER and TIM and the cytosolic and nuclear forms of the PER-TIM complex (see legend to Fig. 1 and Leloup and Goldbeter, 1998, for a definition of the variables and parameters that appear in these equations):

$$\frac{dM_p}{dt} = v_{sp} \frac{K_{IP}^n}{K_{IP}^n + C_N^n} - v_{mp} \frac{M_p}{K_{mP} + M_p} - k_d M_p \quad (1a)$$

$$\frac{dP_0}{dt} = k_{sp} M_p - V_{1P} \frac{P_0}{K_{1P} + P_0} + V_{2P} \frac{P_1}{K_{2P} + P_1} - k_d P_0 \quad (1b)$$

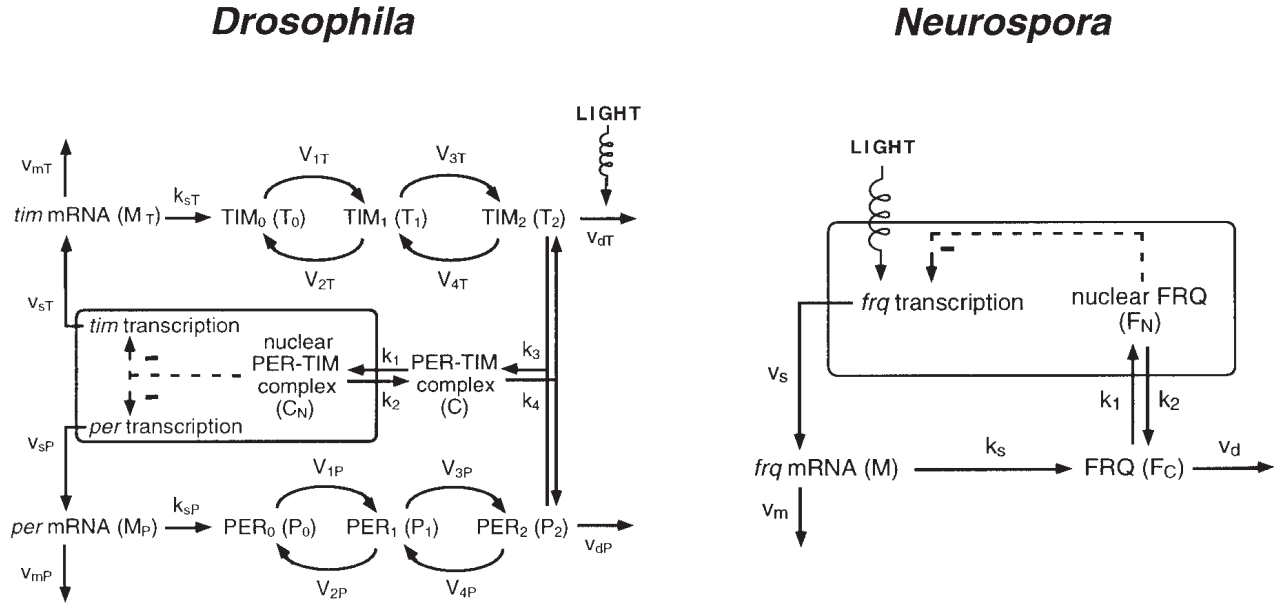

**Figure 1.** (A) Scheme of the extended model for circadian oscillations in *Drosophila* involving negative regulation of gene expression by a complex between PER and TIM (Leloup and Goldbeter, 1998). The *per* ( $M_P$ ) and *tim* ( $M_T$ ) mRNAs are synthesized in the nucleus and transferred into the cytosol, where they accumulate at the maximum rates  $v_{sP}$  and  $v_{sT}$ , respectively; there they are degraded enzymatically at the maximum rates  $v_{mP}$  and  $v_{mT}$ , with the Michaelis constants  $K_{mP}$  and  $K_{mT}$ . The rates of synthesis of the PER and TIM proteins, respectively proportional to  $M_P$  and  $M_T$ , are characterized by the apparent first-order rate constants  $k_{sP}$  and  $k_{sT}$ . Parameters  $V_{iP}$ ,  $V_{iT}$ , and  $K_{iP}$ ,  $K_{iT}$  ( $i = 1, \dots, 4$ ) denote the maximum rate and Michaelis constant of the kinase(s) and phosphatase(s) involved in the reversible phosphorylation of  $P_0$  ( $T_0$ ) into  $P_1$  ( $T_1$ ) and  $P_1$  ( $T_1$ ) into  $P_2$  ( $T_2$ ), respectively. The fully phosphorylated forms ( $P_2$  and  $T_2$ ) are degraded by enzymes of maximum rates  $v_{dP}$ ,  $v_{dT}$ , and Michaelis constants  $K_{dP}$ ,  $K_{dT}$ , and reversibly form a complex  $C$  (with the forward and reverse rate constants  $k_3$ ,  $k_4$ ), which is transported into the nucleus at a rate characterized by the apparent first-order rate constant  $k_1$ . Transport of the nuclear form of the PER-TIM complex ( $C_N$ ) into the cytosol is characterized by the apparent first-order rate constant  $k_2$ . The negative feedback exerted by the nuclear PER-TIM complex on *per* and *tim* transcription is described by an equation of the Hill type, in which  $n$  denotes the degree of cooperativity, and  $K_{iP}$  and  $K_{iT}$  the threshold constants for repression. Light enhances the maximum rate of TIM degradation. (B) Scheme of the model for circadian oscillations in *Neurospora*. The model is based on the negative feedback exerted by the protein FRQ on the transcription of the *frq* gene; the rate of gene expression is enhanced by light. The model includes gene transcription in the nucleus, accumulation of the corresponding mRNA in the cytosol with the associated protein synthesis, protein transport into and out of the nucleus, and regulation of gene expression by the nuclear form of the FRQ protein in *Neurospora*.

$$\frac{dP_1}{dt} = V_{1P} \frac{P_0}{K_{1P} + P_0} - V_{2P} \frac{P_1}{K_{2P} + P_1} - V_{3P} \frac{P_1}{K_{3P} + P_1} + V_{4P} \frac{P_2}{K_{4P} + P_2} - k_d P_1 \quad (1c)$$

$$\frac{dP_2}{dt} = V_{3P} \frac{P_1}{K_{3P} + P_1} - V_{4P} \frac{P_2}{K_{4P} + P_2} - k_3 P_2 T_2 + k_4 C - v_{dP} \frac{P_2}{K_{dP} + P_2} - k_d P_2 \quad (1d)$$

$$\frac{dM_T}{dt} = v_{sT} \frac{K_{iT}^n}{K_{iT}^n + C_N} - v_{mT} \frac{M_T}{K_{mT} + M_T} - k_d M_T \quad (1e)$$

$$\frac{dT_0}{dt} = k_{sT} M_T - V_{1T} \frac{T_0}{K_{1T} + T_0} + V_{2T} \frac{T_1}{K_{2T} + T_1} - k_d T_0 \quad (1f)$$

$$\frac{dT_1}{dt} = V_{1T} \frac{T_0}{K_{1T} + T_0} - V_{2T} \frac{T_1}{K_{2T} + T_1} - V_{3T} \frac{T_1}{K_{3T} + T_1} + V_{4T} \frac{T_2}{K_{4T} + T_2} - k_d T_1 \quad (1g)$$

$$\frac{dT_2}{dt} = V_{3T} \frac{T_1}{K_{3T} + T_1} - V_{4T} \frac{T_2}{K_{4T} + T_2} - k_3 P_2 T_2 + k_4 C - v_{dT} \frac{T_2}{K_{dT} + T_2} - k_d T_2 \quad (1h)$$

$$\frac{dC}{dt} = k_3 P_2 T_2 - k_4 C - k_1 C + k_2 C_N - k_{dc} C \quad (1i)$$

$$\frac{dC_N}{dt} = k_1 C - k_2 C_N - k_{dN} C_N \quad (1j)$$

The total (nonconserved) quantity of PER and TIM proteins,  $P_t$  and  $T_t$ , are given by

$$P_t = P_0 + P_1 + P_2 + C + C_N \quad (2)$$

$$T_t = T_0 + T_1 + T_2 + C + C_N \quad (3)$$

The effect of light can be incorporated in this extended model through modulation of parameter  $v_{dt}$ , which measures the maximum rate of TIM degradation (Leloup and Goldbeter, 1998).

### Model for Circadian Rhythms in *Neurospora*

The molecular mechanisms of circadian oscillations in *Drosophila* and *Neurospora* shown in Fig. 1 indicate that these mechanisms are closely related by the nature of the feedback loop that governs circadian rhythmicity, even if they differ by the identity of the molecules involved in the regulatory circuit. Thus, the role of the PER-TIM complex in the negative feedback on gene expression in *Drosophila* is played by FRQ in *Neurospora*. A further difference pertains to the effect of light, which controls TIM degradation in the fly (Zeng et al., 1996) and *frq* transcription in the fungus (Crosthwaite et al., 1995).

In view of the formal similarity between the two models of Fig. 1, it is natural to resort to similar equations in describing the molecular mechanism of circadian oscillations in the two systems. However, since no complex has been found between FRQ and a second protein in *Neurospora*, the model proposed below for the fungal circadian rhythm is closely related to the model initially proposed for the *Drosophila* rhythm based on the sole regulation by PER (Goldbeter, 1995, 1996).

In *Neurospora*, FRQ can be phosphorylated (Garceau et al., 1997), much as PER and TIM can be in *Drosophila* (Edery et al., 1994; Zeng et al., 1996). Given that the nonphosphorylated form of FRQ enters the nucleus (Garceau et al., 1997) and that oscillations can occur in the model in the absence of phosphorylation (Leloup and Goldbeter, 1998), we disregard in a first

step the covalent modification of the protein. The minimal model for circadian oscillations of FRQ and *frq* mRNA in *Neurospora* is then governed by the following set of three kinetic equations:

$$\frac{dM}{dt} = v_s \frac{K_1^n}{K_1^n + F_N^n} - v_m \frac{M}{K_m + M} \quad (4a)$$

$$\frac{dF_C}{dt} = k_s M - v_d \frac{F_C}{K_d + F_C} - k_1 F_C + k_2 F_N \quad (4b)$$

$$\frac{dF_N}{dt} = k_1 F_C - k_2 F_N \quad (4c)$$

In these equations, the three variables  $M$ ,  $F_C$ , and  $F_N$  denote, respectively, the concentrations (defined with respect to the total cell volume) of the *frq* mRNA and of the cytosolic and nuclear forms of FRQ. The total, non-conserved concentration of FRQ, equal to  $F_C + F_N$ , is denoted by  $F_t$ . Parameter  $v_s$  denotes the rate of *frq* transcription; this parameter increases in the light phase. The other parameters appearing in these equations are the constant  $K_1$ , related to the threshold beyond which nuclear FRQ represses *frq* transcription; the Hill coefficient  $n$ , characterizing the degree of cooperativity of the repression process; the maximum rate  $v_m$  of *frq* mRNA degradation and the Michaelis constant  $K_m$ , related to the latter process; the apparent first-order rate constant  $k_s$  measuring the rate of FRQ synthesis, which is assumed to be proportional to the amount of *frq* mRNA present in the cytosol; the maximum rate  $v_d$  of FRQ degradation and the Michaelis constant  $K_d$ , related to this process; and the apparent first-order rate constants  $k_1$  and  $k_2$  characterizing the transport of FRQ into and out of the nucleus. Phosphorylation of FRQ can readily be incorporated, as was done previously for the case of *Drosophila* (Goldbeter, 1995, 1996; Leloup and Goldbeter, 1998). In the model, this process is not required for sustained oscillations, but it affects their period as well as the magnitude of the domain in which they occur in parameter space (Leloup and Goldbeter, 1998).

The model described by equations 4a-c is closely related to the minimal model originally proposed by Goodwin (1965) for oscillations due to negative control of gene expression. The latter model has recently been used by Ruoff et al. (1999) to account for phase shifts of circadian rhythms by inhibitors of protein synthesis and degradation in *Neurospora*. The system

considered by Ruoff et al. also contains three variables, but the major difference with respect to equations 4a-c is that these authors resort to a repression function characterized by a very high value of 9 for the Hill coefficient, because of the linear nature of the other terms in their equations. Moreover, for the parameter values listed in Table 1 of Ruoff et al. (1999), oscillations are (slowly) damped rather than sustained. Here, because of the nonlinear, Michaelian nature of the degradation kinetics of the protein and its mRNA, sustained oscillations can occur for much smaller values of the Hill coefficient for repression, for example, 4 or 2, and even in the absence of cooperativity of repression when the Hill coefficient is equal to unity (Leloup and Goldbeter, 1998), although cooperativity definitely favors the occurrence of sustained oscillations.

#### EFFECT OF LIGHT-DARK CYCLES AND OF CONTINUOUS DARKNESS OR LIGHT

Shown in Fig. 2A are the oscillations in total PER protein ( $P_t$ ), *per* mRNA ( $M_p$ ), and nuclear PER-TIM complex ( $C_N$ ) obtained in the *Drosophila* model in conditions corresponding to constant darkness; such conditions are achieved in the extended model by holding parameter  $v_{dr}$  at a constant, low value. Although the environmental conditions remain constant, the PER-TIM control system generates autonomous oscillations with a period close to 24 h for the set of parameter values considered. These oscillations are of the limit cycle type (see Fig. 7A below and Goldbeter, 1995, 1996). The corresponding oscillations obtained in conditions of entrainment by light-dark cycles are shown in Fig. 2B. In such conditions, parameter  $v_{dr}$  varies in a square-wave manner as it increases up to a higher value during each light phase. As the duration of both the light and dark phases is equal to 12 h in the case considered (this particular light-dark cycle is denoted by 12:12 LD), the system is entrained precisely to the 24-h external periodicity.

As for the case of oscillations in *Drosophila* illustrated in Fig. 2 A,B in conditions of constant darkness and 12:12 cycle, panels C and D of Fig. 2 show the corresponding oscillations produced by the model for circadian rhythms in *Neurospora*. Here, the parameter that varies with light is the rate of *frq* transcription,  $v_s$ . This parameter remains at a low value during the dark phase and increases up to a higher value during the light phase. In the case considered in Fig. 2D, the sys-

tem is entrained precisely to the external period equal to 24 h, whereas it produces autonomous oscillations of a period close to 21.5 h in constant darkness (Fig. 2C), as observed in the experiments (Garceau et al., 1997).

The curves in Fig. 2C indicate that the peak in total FRQ precedes by 1.1 h the peak in nuclear FRQ. A qualitatively similar phase relationship between total PER and the nuclear PER-TIM complex is obtained in the model for circadian rhythms in *Drosophila* (Fig. 2A). While experiments in the fly show that nuclear PER reaches its peak after the total amount of protein (Curtin et al., 1995), the situation is not fully clear in the fungus. There, the only data available so far seem to indicate that nuclear FRQ reaches its peak a few hours before total FRQ (Luo et al., 1998). Since the model predicts a different phase relationship, it would be of particular interest to determine the temporal variation of *frq* mRNA, of the total amount of FRQ, and of both the nuclear and cytoplasmic forms of the protein at shorter time intervals, for example, every hour, so as to characterize more precisely the phase relationships between these variables.

The circadian models proposed for the two organisms allow us to consider additional aspects of the periodic forcing of circadian clocks by LD cycles. Experiments carried out in *Drosophila* with 8:16, 12:12, and 16:8 LD cycles (Qiu and Hardin, 1996) have shown that the peak of *per* mRNA follows by about 4 h the onset of the dark phase, regardless of the relative duration of the light and dark phases in such LD cycles of 24-h period. Simulations of the extended model schematized in Fig. 1 account for such observations and indicate that the beginning of the dark phase corresponds to a drop in TIM degradation, which allows the rise in TIM; the subsequent increase in the PER-TIM complex up to the level beyond which repression occurs and mRNA begins to decrease takes the same time in all cases, hence the locking of the peak in *per* mRNA to the onset of the dark phase (Leloup and Goldbeter, manuscript in preparation). As shown in Fig. 3A, where three values are considered for the light-induced increase in maximum rate of TIM degradation, this result is, to a large extent, independent of the magnitude of the increase in TIM degradation triggered by light.

The situation is somewhat different in the model for *Neurospora* circadian rhythms. There, as shown in Fig. 3B, the phase of the entrained rhythm in *frq* mRNA varies with respect to the phase of the LD cycle, depending on the magnitude of the increase in

## Drosophila

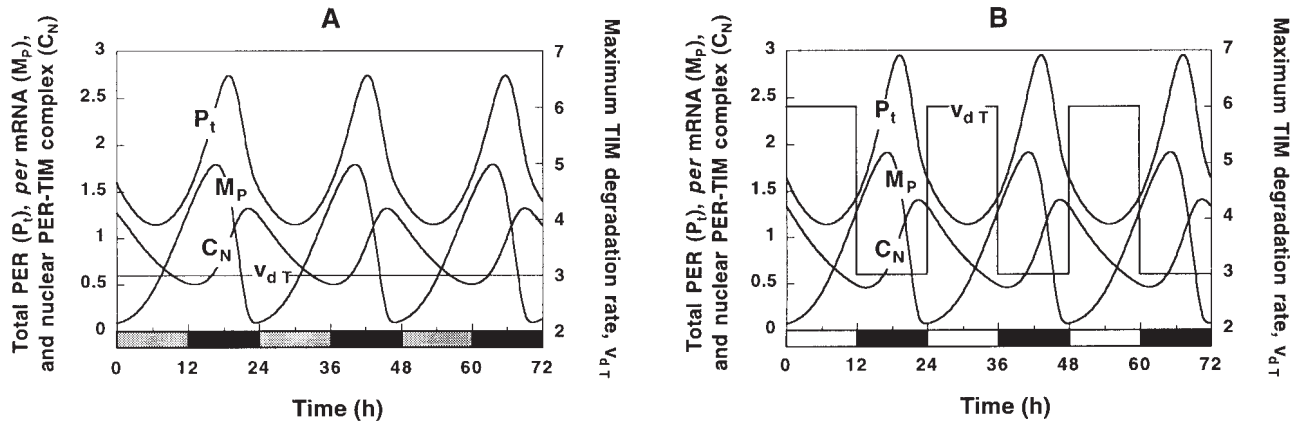

## Neurospora

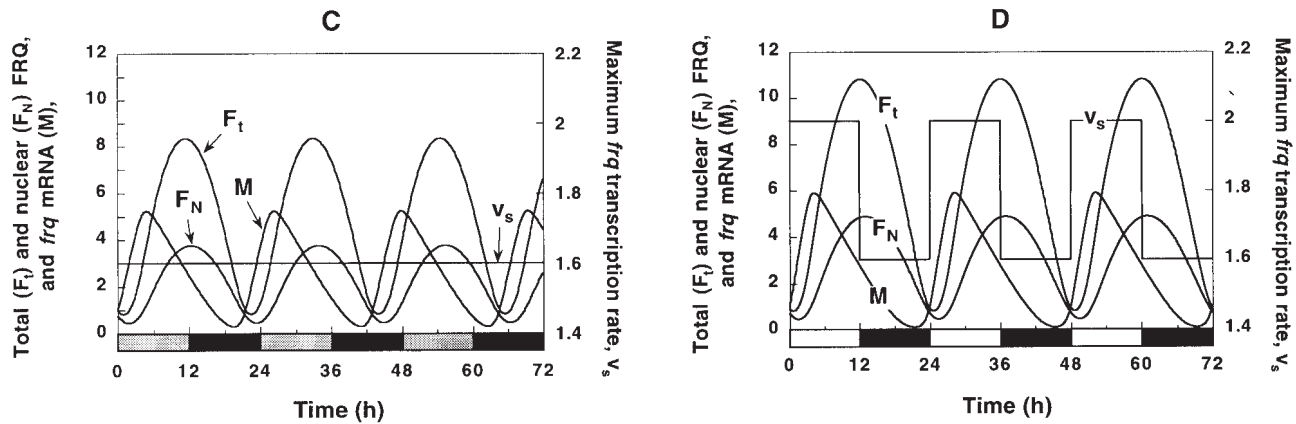

**Figure 2.** Sustained oscillations generated by the model based on negative control of *per* and *tim* expression by a PER-TIM complex in *Drosophila* (panels A and B) and *Neurospora* (panels C and D). The curves in panels A and C correspond to continuous darkness, whereas those in panels B and D correspond to entrainment by an LD cycle of a 24-h period (12:12 LD). The LD cycle is symbolized by the alternation of white and black bars at the bottom of panels B and D; continuous darkness is symbolized in panels A and C by the alternation of gray and black bars. The curves for *Drosophila* have been obtained by numerical integration of the 10 kinetic equations 1 a-j governing the dynamics of the extended model schematized in Fig. 1A. Shown is the temporal variation in *per* mRNA ( $M_P$ ) and in the total amount of PER protein ( $P_t$ ), together with the variation in nuclear PER-TIM complex ( $C_N$ ). Parameter values are  $n = 4$ ,  $v_{SP} = 1.1 \text{ nMh}^{-1}$ ,  $v_{ST} = 1 \text{ nMh}^{-1}$ ,  $v_{MP} = 1.0 \text{ nMh}^{-1}$ ,  $v_{MT} = 0.7 \text{ nMh}^{-1}$ ,  $v_{dT} = 2.2 \text{ nMh}^{-1}$ ,  $k_{SP} = k_{ST} = 0.9 \text{ h}^{-1}$ ,  $k_1 = 0.8 \text{ h}^{-1}$ ,  $k_2 = 0.2 \text{ h}^{-1}$ ,  $k_3 = 1.2 \text{ nM}^{-1} \text{ h}^{-1}$ ,  $k_4 = 0.6 \text{ h}^{-1}$ ,  $K_{MP} = K_{MT} = 0.2 \text{ nM}$ ,  $K_{IP} = K_{IT} = 1 \text{ nM}$ ,  $K_{dP} = K_{dT} = 0.2 \text{ nM}$ ,  $K_{IP} = K_{IT} = K_{2P} = K_{2T} = K_{3P} = K_{3T} = K_{4P} = K_{4T} = 2 \text{ nM}$ ,  $V_{IP} = V_{IT} = 8 \text{ nMh}^{-1}$ ,  $V_{2P} = V_{2T} = 1 \text{ nMh}^{-1}$ ,  $V_{3P} = V_{3T} = 8 \text{ nMh}^{-1}$ ,  $V_{4P} = V_{4T} = 1 \text{ nMh}^{-1}$ ,  $k_d = k_{dC} = k_{dN} = 0.01 \text{ nMh}^{-1}$ . Parameter  $v_{dT}$  (in  $\text{nMh}^{-1}$ ) remains constant and equal to 3 in (A), and is equal in (B) to 3 and 6 during the dark and light phases, respectively. For the case of *Neurospora* (bottom panels), the curves have been obtained by numerical integration of equations 4 a-c. Parameter values are  $v_m = 0.505 \text{ nMh}^{-1}$ ,  $v_d = 1.4 \text{ nMh}^{-1}$ ,  $k_s = 0.5 \text{ h}^{-1}$ ,  $k_1 = 0.5 \text{ h}^{-1}$ ,  $k_2 = 0.6 \text{ h}^{-1}$ ,  $K_m = 0.5 \text{ nM}$ ,  $K_I = 1 \text{ nM}$ ,  $K_d = 0.13 \text{ nM}$ ,  $n = 4$ . Parameter  $v_s$  (in  $\text{nMh}^{-1}$ ) remains constant and equal to 1.6 in (C), and is equal in (D) to 1.6 and 2 during the dark and light phases, respectively. The concentration scale is expressed, tentatively, in nM. Given that quantitative experimental data are still lacking, the above parameter values, which are in a physiological range, have been selected arbitrarily so as to yield a period close to 24 h in *Drosophila* and 21.5 h in *Neurospora*; these are the periods of the oscillations observed in constant darkness in these organisms.

*frq* transcription triggered by light. The four curves shown in Fig. 3B correspond to nearly equal increments in parameter  $v_s$ . Whereas the peak in mRNA after entrainment occurs before the half of the

phase of the LD cycle at the lower values of  $v_s$ , at higher values the mRNA peak shifts toward the beginning of the dark phase. In Fig. 3B, curves a and b, and curves c and d, are closer to each other than curves

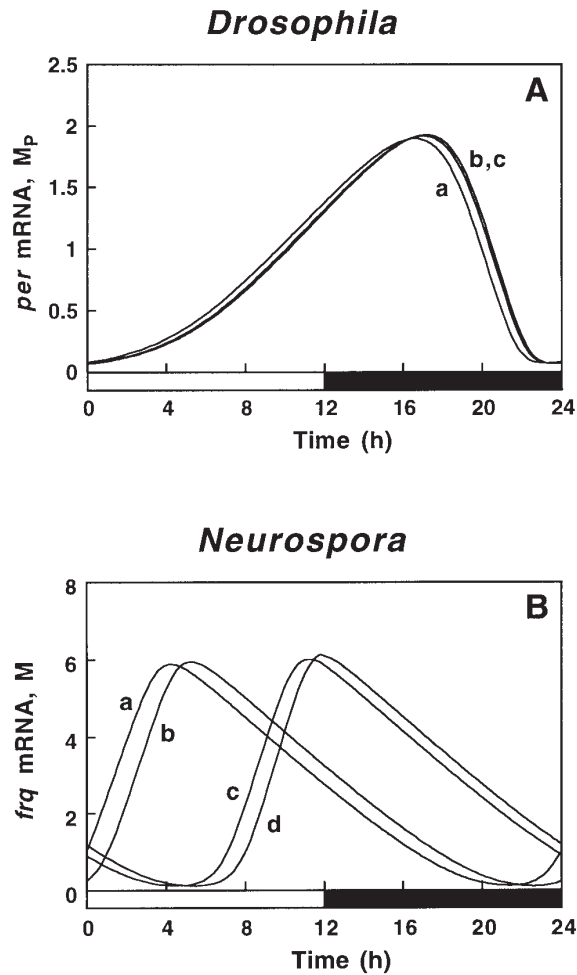

**Figure 3.** Entrainment by LD cycles: influence of the magnitude of the change in the light-dependent parameter on the phase of the entrained oscillations (A) in the *Drosophila* model and (B) in the *Neurospora* model. Curves a, b, and c in (A) are obtained by numerical integration of equations 1 a-j for LD cycles in which  $v_{dt}$  passes from a basal value of 3 to 4, 6 and 9 (in nMh<sup>-1</sup>), respectively; other parameters are as in Fig. 2A. Curves a to d in (B) are obtained by numerical integration of equations 4 a-c for LD cycles in which  $v_s$  passes from a basal value of 1.6 to 2.0, 2.15, 2.25, and 2.4 (in nMh<sup>-1</sup>), respectively; other parameters are as in Fig. 2C.

b and c, which denotes a threshold in the dependence of the phase on the magnitude of the increase in  $v_s$  triggered by light.

The difference predicted by the models for the entrainment patterns in a 12:12 LD cycle for *Drosophila* and *Neurospora* is due to the difference in free-running period in the two organisms. This period is close to 24 h in *Drosophila*, whereas, in contrast, it is of the order of 21.5 h in *Neurospora*. The latter value differs signifi-

cantly from the period of 24 h of the LD cycle, which is not the case for *Drosophila*. That the difference between free-running period and period of the LD cycle is indeed the cause of the distinct patterns of phase locking illustrated in panels A and B of Fig. 3 is shown by the fact that the pattern of panel B changes into that of panel A when the rhythm is entrained by a 11:11 LD cycle (the peak in mRNA then occurs near the end of the light phase). Conversely, when parameters for the *Drosophila* model are taken to yield a free-running period of 21.5 h, the pattern in A changes more or less into that shown in panel B: as the value of  $v_{dt}$  reached during the light phase increases, the peak in mRNA shifts from the beginning of the dark phase to some 4 h thereafter.

In contrast to what is observed in constant darkness, circadian rhythms in *Drosophila* are damped in constant light (Qiu and Hardin, 1996). Such a situation is apparently not observed in *Neurospora*. These observations are accounted for by the behavior predicted in Figs. 4A and 4C, in conditions of constant light, by the models for circadian rhythms in *Drosophila* and *Neurospora*. To explore how the models can account for these observations, we have constructed bifurcation diagrams showing the domain of sustained oscillations as a function of the light-controlled parameter in each of the two models.

Thus, in panel B of Fig. 4 the domain of existence of sustained oscillations in the *Drosophila* model is shown as a function of the light-controlled parameter,  $v_{dt}$ . For the set of parameter values considered, sustained oscillations occur in a domain bounded by two critical values of this parameter. The vertical arrows at the bottom of the figure inside and outside this domain refer to values of  $v_{dt}$  that could correspond, respectively, to the occurrence of sustained oscillations in continuous darkness (DD) and damped oscillations in continuous light (LL); the oscillations associated with these two values of  $v_{dt}$  are shown in Figs. 2A and 4A, respectively.

In *Neurospora*, the situation might be different since available data do not allow us to conclude whether oscillations are damped in constant light. The data in Fig. 5A of Crosthwaite et al. (1995) were obtained for 36 h only and do not show any clear suppression of the oscillations by then. In case oscillations were damped in LL, the bifurcation diagram as a function of the light-controlled parameter,  $v_s$ , would resemble that shown in Fig. 4B. However, for other parameter val-

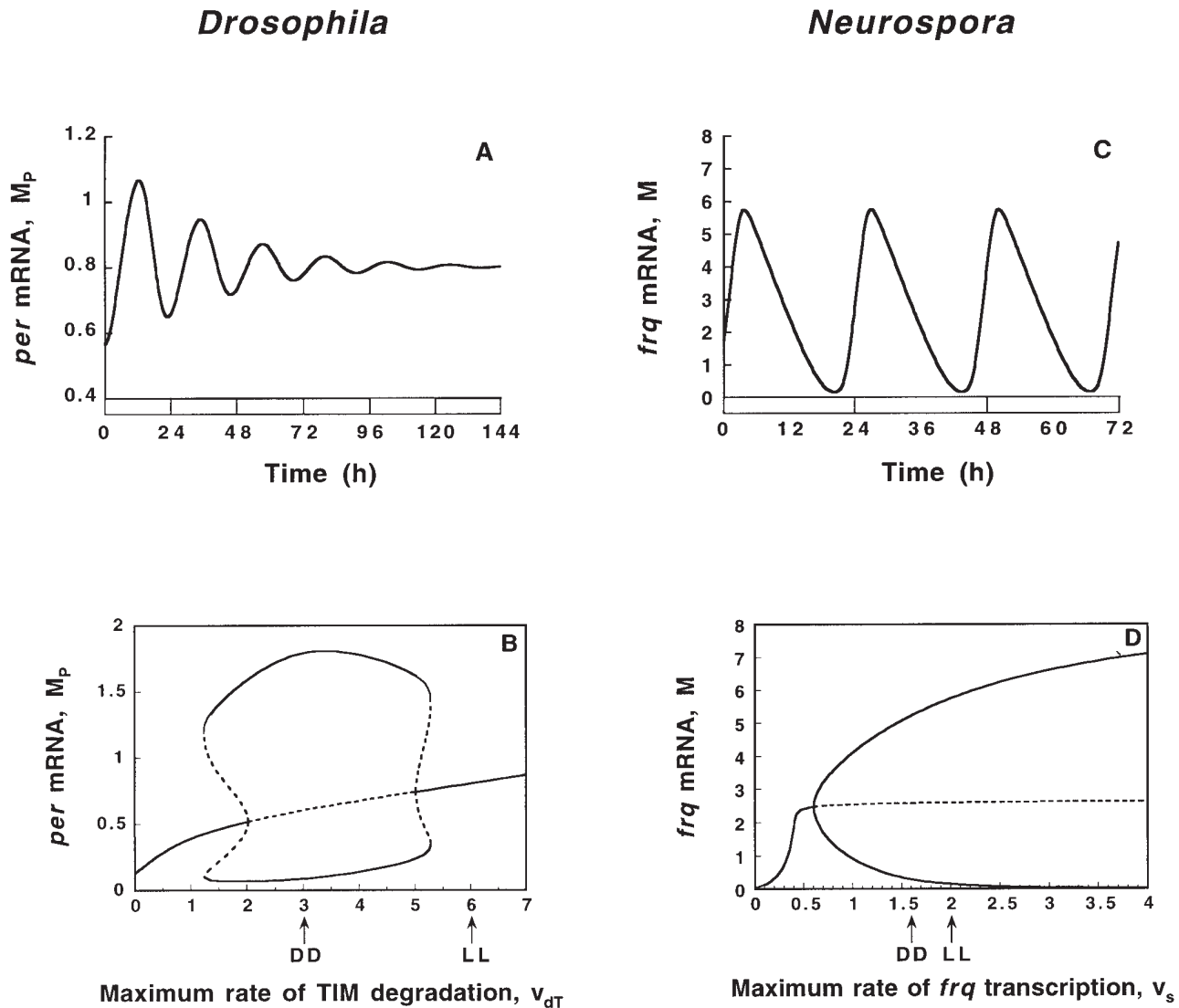

Figure 4. Effect of continuous light or darkness in the models for circadian oscillations in *Drosophila* (left column) and *Neurospora* (right column). The bottom panels show the bifurcation diagrams as a function of the light-controlled parameter,  $v_{dT}$  in *Drosophila*, and  $v_s$  in *Neurospora*. Each of these diagrams represents the steady-state value, stable (solid line) or unstable (dashed line), as well as the maximum and minimum value of *per* mRNA (B) or *frq* mRNA (D) as a function of the control parameter in the course of sustained oscillations. Other parameter values in panels A and B, and in panels C and D, are as in Figs. 2 A and C, respectively. The arrows at the bottom exemplify conditions corresponding to continuous light (LL) or darkness (DD). (A) Damped oscillations in the *Drosophila* model, obtained for the value  $v_{dT} = 6 \text{ nMh}^{-1}$  corresponding to continuous light in the diagram of panel B. (C) Sustained oscillations in the *Neurospora* model, obtained for the value  $v_s = 2 \text{ nMh}^{-1}$  corresponding to continuous light in the diagram of panel D. The curves in panels A and C are obtained as in Figs. 2 A and C, respectively.

ues, the model for *Neurospora* can also produce a bifurcation diagram such as that shown in Fig. 4D. There, oscillations are sustained in either DD or LL. In any case, the results of Fig. 4D suggest that LL should not necessarily lead to the damping of circadian oscillations, nor to a reduction in their amplitude (Peterson, 1980), even though such effects may be accounted for by the models, as shown in Fig. 4B.

#### EFFECT OF LIGHT PULSES: PHASE RESETTING AND RHYTHM SUPPRESSION

The extended model schematized in Fig. 1A has been used (Leloup and Goldbeter, 1998) to account for the altered rhythmic behavior of mutants of the *Drosophila* circadian clock, such as the long-period (*per<sup>l</sup>*) and



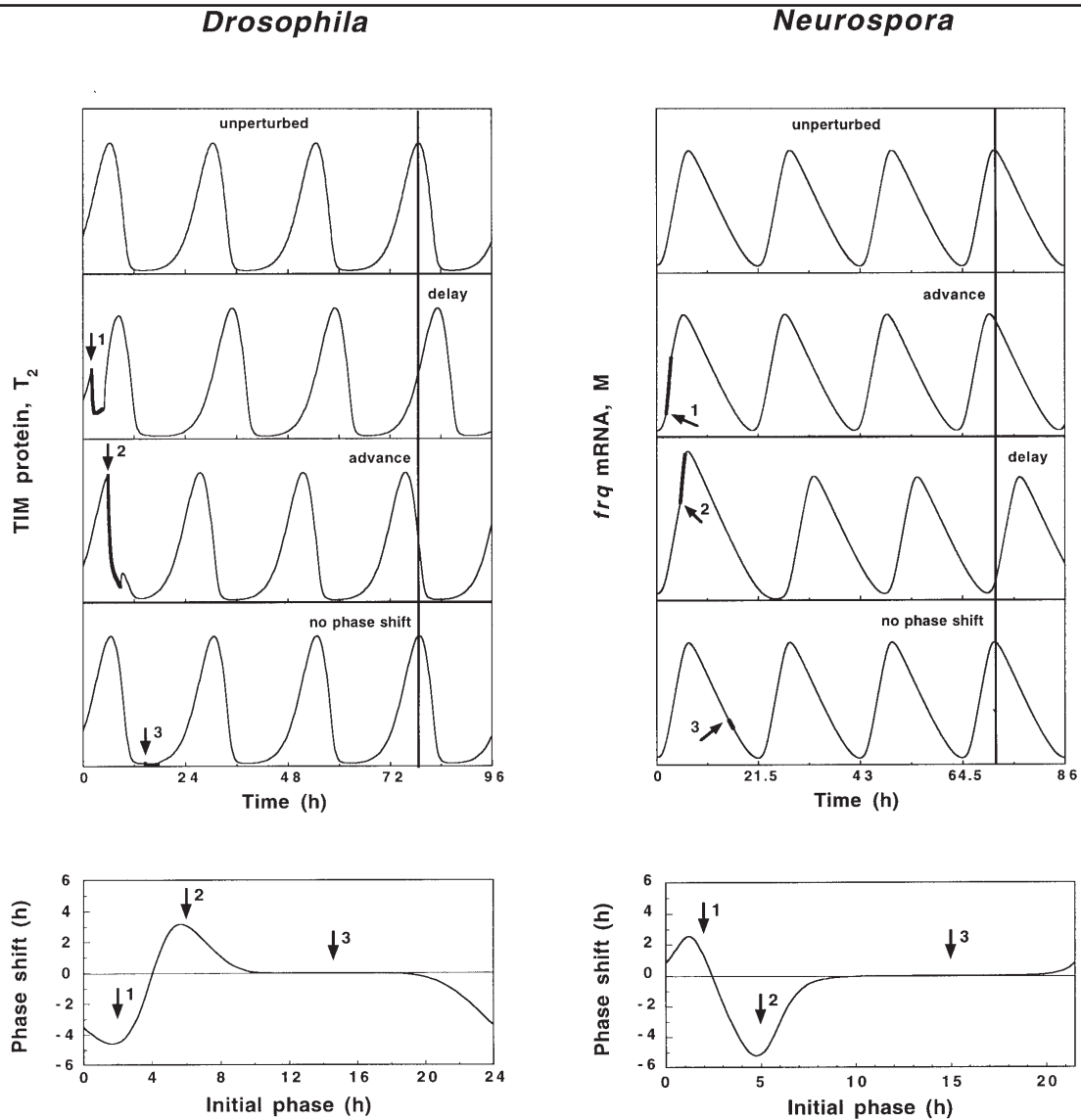

**Figure 5.** Light-induced phase shifts obtained theoretically for a perturbation (arrow) applied at three different phases of the oscillations in *Drosophila* (left column) and *Neurospora* (right column). For the *Drosophila* model, the top panel represents the unperturbed oscillations; the three panels below it illustrate, successively, the cases of phase delay, phase advance, or absence of phase shift in response to the perturbation. The bottom panel represents the full phase response curve showing the phase shift as a function of the initial phase at which the perturbation is applied; the initial phase spans the first 24-h interval of the unperturbed oscillations in the top panel. The perturbation takes the form of a 3-h long, twofold increase in TIM degradation ( $v_{dT}$ ) triggered by light. For the *Neurospora* model, the top panel represents the unperturbed oscillations; the three panels below it illustrate, successively, the cases of phase advance, phase delay, or absence of phase shift in response to the perturbation. As for the *Drosophila* model, the bottom panel represents the full phase response curve; the initial phase spans the first 21.5-h interval of the unperturbed oscillations in the top panel. The perturbation here takes the form of a 1-h long, twofold increase in *frq* transcription rate ( $v_s$ ) triggered by light. The arrows mark the beginning of the light pulse and the thick lines indicate both the duration and the effect of this perturbation. The light-controlled variable represented for *Drosophila* and *Neurospora* is the degradable form of the TIM protein ( $T_2$ ) and *frq* mRNA, respectively. Parameter values for the right column are as in Fig. 2C; for the left column, parameter values are as in Fig. 2 of our previous publication (Leloup and Goldbeter, 1998).

short-period (*per<sup>s</sup>*) mutants (Konopka and Benzer, 1971). This model also accounts for the phase response curves (PRCs) obtained experimentally for the wild type (*per<sup>+</sup>*) and for the *per<sup>s</sup>* mutant (Leloup and Goldbeter, 1998) in response to light. By varying the strength and the duration of the perturbation by light

pulses, we used the model to generate a family of PRCs yielding the phase shift of circadian oscillations as a function of the phase at which the perturbation is applied. Obtaining such a family of curves is useful, because the effect of a light pulse remains unknown in terms of both the magnitude and the effective dura-

tion of the biochemical changes that it produces. Thus, even if a light pulse is brief, it can lead to the synthesis of an enzyme that could remain active for hours.

The best agreement with experiments (Hall and Rosbash, 1987) was found when considering that the effect of a light pulse is to double the maximum rate of TIM degradation during a period of 3 h. Shown in the left part of Fig. 5, from top to bottom, are the unperturbed oscillations of the biphosphorylated form of the TIM protein, and three situations marked 1-3 in which the light pulse causes, respectively, a phase delay, a phase advance, and no phase shift, depending on the phase at which the pulse is applied. The bottom panel gives the full PRC as a function of the initial phase; the initial phase of 12 h corresponds to the minimum of *per* mRNA oscillations. A phase delay is obtained when the light pulse is given during the rising phase of TIM, since the light-induced decrease in TIM is followed by the production of a quasi-normal peak of the protein. A phase advance occurs when the light pulse is applied near the maximum of TIM or during the decreasing phase of the protein, because the latter reaches its minimum prematurely as a result of the perturbation and is not immediately followed by the production of a significant peak. No phase shift is observed when the light pulse occurs when TIM is near its minimum, because the effect of light is then negligible.

As shown previously (see Fig. 6 in Leloup and Goldbeter, 1998), the theoretical results yield excellent agreement with experimental data obtained for the PRC in wild type *Drosophila*. The agreement between model and experiment extends to the case of the *per<sup>s</sup>* mutant. The theoretical curve for this mutant is obtained by taking a larger rate of nuclear degradation of the PER-TIM complex, as suggested by experimental observations (Curtin et al., 1995). A major difference between the PRC obtained for the wild type and for the *per<sup>s</sup>* mutant is the existence in the former of a much larger "dead zone" in which no significant phase shift occurs. A comparison of these curves indicates that the larger dead zone seen in the wild type could be due to the fact that TIM levels are more depressed, and during a longer time, at the trough of the oscillations in *per<sup>+</sup>* than they are in *per<sup>s</sup>*, so that the absence of phase shift induced by light is prolonged in the wild type (Leloup and Goldbeter, 1998).

The effect of light pulses on the *Neurospora* rhythm is illustrated in the right part of Fig. 5. As for the corresponding situation in *Drosophila*, from top to bottom are the unperturbed oscillations of the *frq* mRNA

(rather than the FRQ protein, because the effect of light here is to induce *frq* transcription rather than protein degradation as in *Drosophila*) and three situations marked 1-3 in which the light pulse results, respectively, in a phase advance, a phase delay, and no phase shift, depending on the phase at which the pulse is applied. The bottom panel gives the full PRC as a function of the initial phase; as indicated in the upper panel, the initial phase of 0 h corresponds to the minimum of *frq* mRNA oscillations. When the light pulse is applied near the minimum of *frq* mRNA, enhanced transcription results in the next maximum being reached prematurely. When the light pulse occurs during the rising phase of *M* and near its maximum, the resulting peak in mRNA is larger and the following minimum is lower (because of the increased level of FRQ), so that the next maximum is delayed. No phase shift occurs when the light pulse hits the system during the decreasing phase of *M*, because the light-induced increase in mRNA synthesis cannot overcome the repression exerted by the protein FRQ that is close to its maximum level.

In the model for *Drosophila*, in conditions of Fig. 4B, a stable steady state sometimes coexists with a stable limit cycle. This situation, corresponding to hard excitation, is schematized in the upper left panel in Fig. 6. Then, when delivered at the right phase, a light pulse of appropriate duration and magnitude (modeled by a transient increase in parameter  $v_{dt}$ ) can bring the system beyond an unstable limit cycle into the basin of attraction of the stable steady state (situation a). When the perturbation is not of appropriate magnitude and duration, or when it is not applied at an appropriate phase, limit cycle oscillations resume (situation b). Case a illustrates the suppression of rhythmic behavior. Such a suppression is permanent, in contrast to what happens when the pulse is given in the more common conditions (schematized in the upper right panel in Fig. 6) in which the stable limit cycle does not coexist with a stable steady state. If the pulse brings the system back into the vicinity of the steady state, because this state is unstable, oscillations will immediately start growing in amplitude until the limit cycle is reached again (situation c). The return to the limit cycle becomes faster when the perturbation fails to bring the system close to steady state (situation d).

The analysis of the model by computer simulations shows that permanent suppression of circadian rhythmicity in conditions of hard excitation can be achieved only during a portion of the limit cycle corresponding roughly to the rising phase of TIM. In this range, at

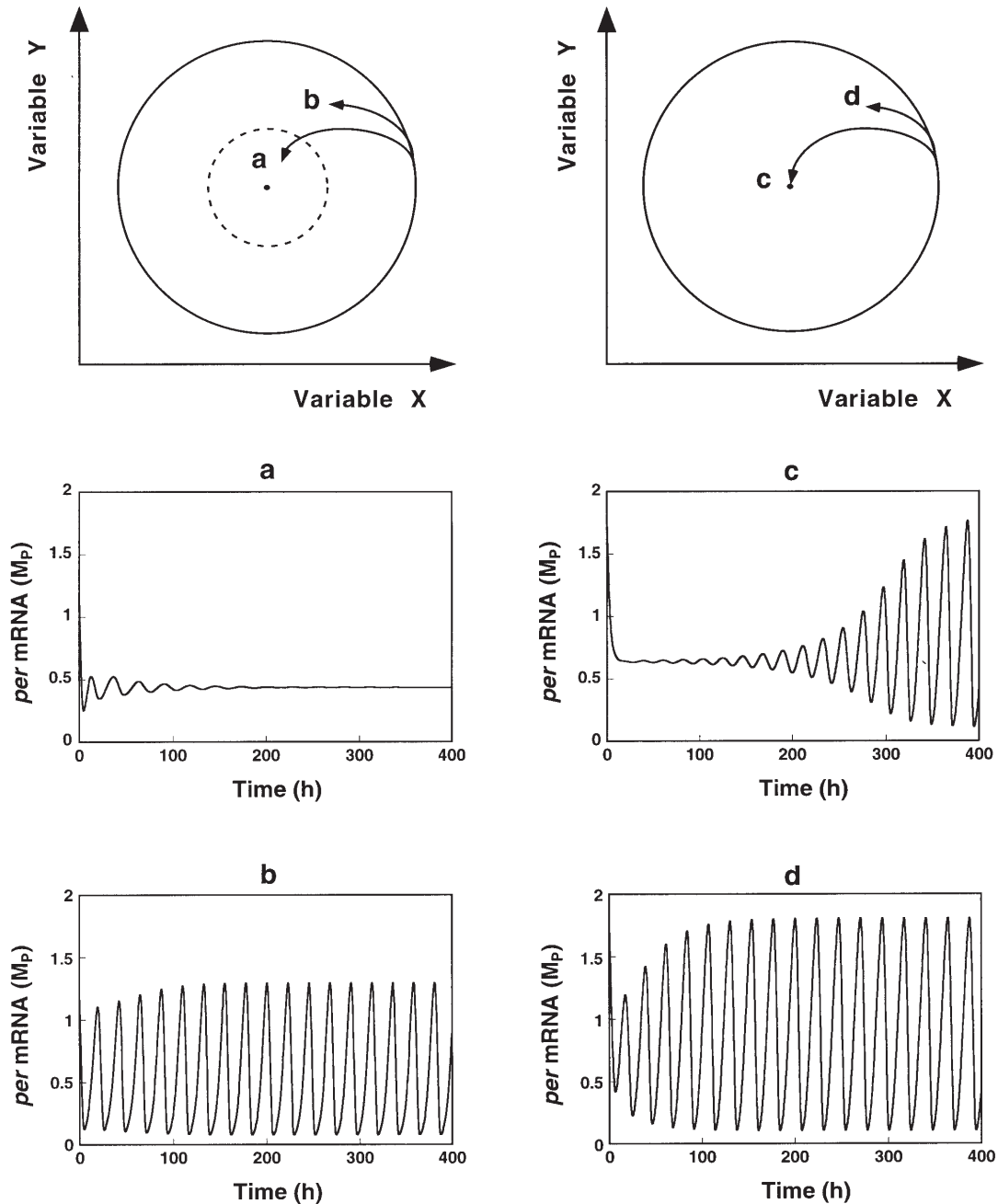
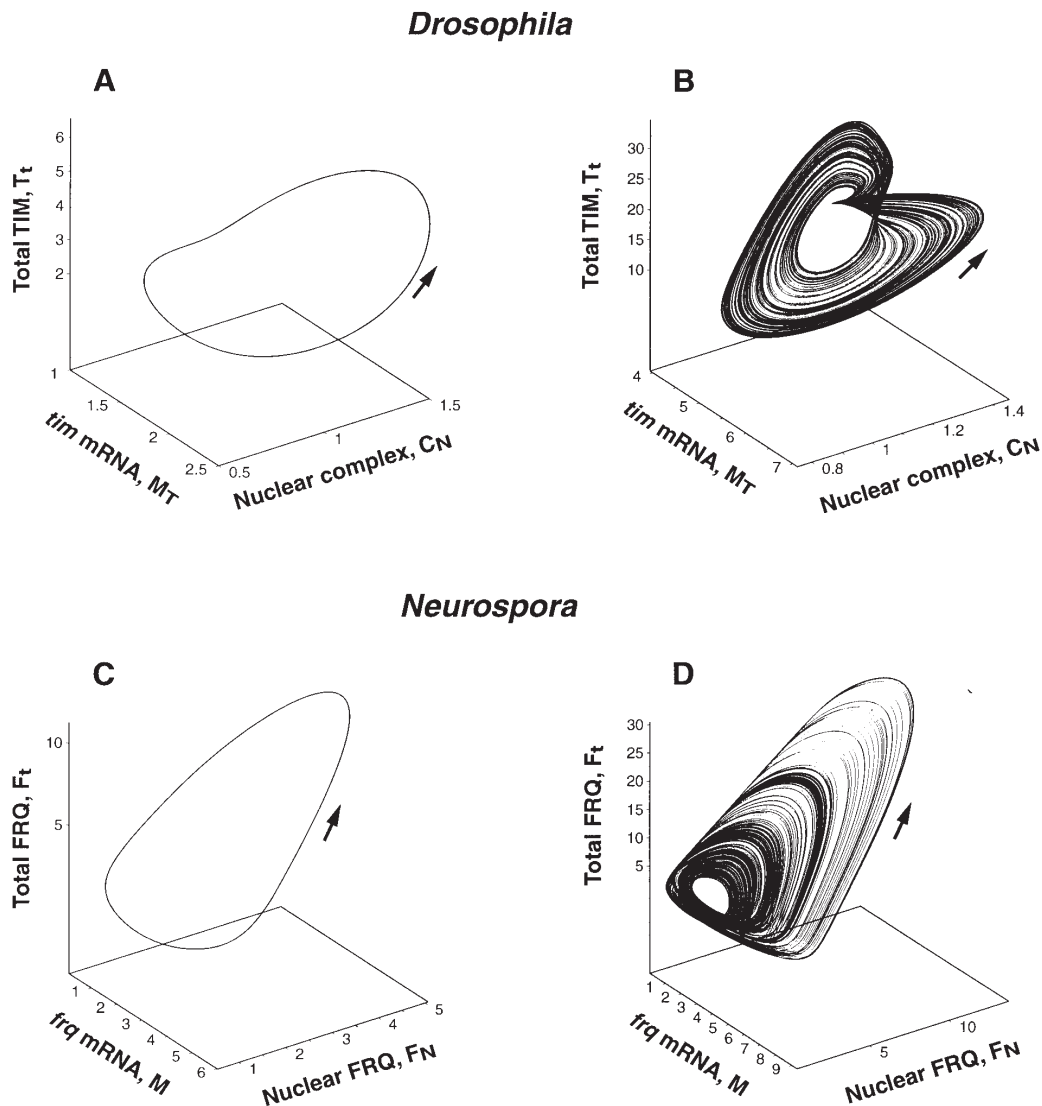

Figure 6. Permanent or transient suppression of circadian rhythmicity by light pulses in the *Drosophila* clock model. The three panels on the left refer to the coexistence between a stable limit cycle and a stable steady state (case of hard excitation). The dashed line corresponds to an unstable limit cycle. Parameter  $v_{dT}$  is increased during 2 h from the basal value of  $1.3 \text{ nMh}^{-1}$  up to  $4.0$  (a) or  $2.5$  (b)  $\text{nMh}^{-1}$ . Initial conditions correspond to a point on the limit cycle where  $M_p = 1.154$ ;  $M_T = 2.293$  (in nM). Situation a corresponds to the permanent suppression of the rhythm. The three panels on the right pertain to the situation of a stable limit cycle and an unstable steady state (case of soft excitation). Parameter  $v_{dT}$  is increased during 3.8 h from the basal value of  $3.5 \text{ nMh}^{-1}$  up to  $6.7$  (c) or  $5.0$  (d)  $\text{nMh}^{-1}$ . Initial conditions correspond to a point on the limit cycle where  $M_p = 1.711$ ;  $M_T = 3.978$  (in nM). Situation c corresponds to transient suppression of the rhythm.

each phase of the oscillations, successful perturbations correspond to a domain in the (duration-magnitude) plane that changes with the phase at which the suppressive perturbation is applied (J.-C. Leloup and A. Goldbeter, manuscript in preparation).

The suppression of rhythmic behavior by critical perturbations has long been proposed as a way to characterize limit cycle oscillations (Winfree, 1980). Suppression of circadian rhythmicity by critical light pulses has been observed in humans (Jewett et al.,



**Figure 7.** Limit cycles and strange attractors in the models for circadian oscillations in *Drosophila* (upper panels) and *Neurospora* (bottom panels). (A) Limit cycle corresponding to the sustained oscillations shown in Fig. 2A in conditions of continuous darkness. (B) Strange attractor corresponding to autonomous chaotic oscillations in conditions of continuous darkness; parameter values are as in Fig. 2 of our previous publication (Leloup and Goldbeter, 1998), with  $v_{mT} = 0.35$  and  $v_{dT} = 4.9$  (in  $\text{nMh}^{-1}$ ). (C) Limit cycle corresponding to the sustained oscillations shown in Fig. 2C in conditions of continuous darkness. (D) Strange attractor corresponding to chaotic oscillations in conditions where the system governed by equations 4 a-c is forced by a 12:12 LD cycle during which parameter  $v_s$  varies from 1.6 in the dark phase to 4.7 (in  $\text{nMh}^{-1}$ ) in the light phase.

1991). It is of interest that the model for circadian rhythms in *Drosophila* can account for this kind of observation.

#### PERIODIC OSCILLATIONS VERSUS CHAOS

Sustained oscillations that occur in the models for circadian rhythms in *Drosophila* and *Neurospora* are

generally of a periodic nature and correspond to limit cycle oscillations (see Fig. 7, panels A and C). We have found chaotic oscillations in two different instances in these models. Thus, autonomous chaos occurs in a small region of parameter space in the model for *Drosophila* rhythms (Fig. 7B), in conditions corresponding to DD (Leloup and Goldbeter, 1999). This behavior, which corresponds to the evolution toward a strange attractor, results from the interplay between the PER and TIM branches of the feedback regulatory loop that

lies at the core of the oscillatory mechanism. Nonautonomous chaos can also be obtained, both in the *Drosophila* and *Neurospora* models, in conditions of periodic forcing by LD cycles, as shown in Fig. 7D for the case of *Neurospora* (Gonze et al., 1999).

The physiological significance of chaotic oscillations remains questionable with regard to circadian rhythmicity, because such behavior is much less frequent than periodic oscillations in parameter space. Moreover, it is likely that chaos is not related to the phenotype of arrhythmic mutants in *Drosophila* in which the altered oscillatory properties appear to be related to the loss of functional PER or TIM proteins.

#### FURTHER PROPERTIES AND EXTENSIONS OF THE MODEL FOR CIRCADIAN RHYTHMS IN *DROSOPHILA*

The model for *Drosophila* circadian rhythms also allowed us to show that the phosphorylation of PER and TIM and the formation of a complex between the PER and TIM proteins favor rhythmic behavior as these processes result in the enlargement of the domain of sustained oscillations in parameter space (Leloup and Goldbeter, 1998). Finally, we examined in the simpler model based on PER alone the origin of temperature compensation (Leloup and Goldbeter, 1997). This property, by which the period remains largely independent from temperature, is characteristic of circadian rhythms and arises in the model from the antagonistic effects exerted on the period by the different kinetic parameters, which vary with temperature.

The model based on PER and TIM can further be extended by incorporating the role of newly discovered gene products. Thus, sustained oscillations are still obtained when including the CLOCK and CYCLE proteins, which behave as transcriptional activators for *per* and *tim* (Allada et al., 1998; Darlington et al., 1998; Rutila et al., 1998). In this version of the model, the PER-TIM complex binds to the CLOCK-CYCLE complex and thereby inhibits the transcription of the *per* and *tim* genes. The possibility of posttranscriptional regulation suggested by some experiments (So and Rosbash, 1997) has also been investigated; the model shows that such a regulatory mechanism can still give rise to oscillations in PER and TIM even if the negative regulation at the genetic level is impaired. Finally, the model accounts for the occurrence of sustained oscillations of PER and TIM in the presence of a

constant level of *per* mRNA (Cheng and Hardin, 1998), but only if *tim* mRNA is allowed to vary. The model shows that the oscillations in *tim* mRNA due to the still active feedback loop involving the PER-TIM complex are sufficient to give rise to periodic behavior (Leloup and Goldbeter, manuscript in preparation).

#### DISCUSSION

The analysis of circadian rhythms in terms of limit cycle oscillations has been explored along two main lines of research during the past four decades. One approach, still being pursued fruitfully, is to resort to physical models such as the van der Pol oscillator, to address properties of circadian rhythms such as the response to light pulses. The other approach, initiated by Goodwin (1965), is to examine molecular regulatory mechanisms capable of producing sustained oscillations of the limit cycle type. Thanks to the remarkable experimental advances made in recent years on the molecular bases of circadian rhythmicity in a variety of organisms such as *Drosophila* and *Neurospora*, the study of limit cycle models based on molecular regulatory mechanisms can be developed to a point where the state variables and the biochemical parameters of circadian clocks are largely identified in molecular terms.

In this article, we have discussed such limit cycle models based on transcriptional regulation for circadian rhythms in *Drosophila* and *Neurospora*. In *Drosophila*, circadian oscillations of the PER and TIM proteins and of their mRNAs are accounted for by the extended model schematized in Fig. 1A, in which negative feedback on the expression of the *per* and *tim* genes is exerted by the PER-TIM complex. A similar model (Fig. 1B) based on the negative feedback exerted by the protein FRQ on the expression of the *frq* gene may account for the origin of circadian oscillations of FRQ and *frq* mRNA in *Neurospora*. The endogenous nature of the oscillations is reflected by the fact that they occur in constant environmental conditions, for example, DD.

The models take into account the different effects of light in the two organisms. Thus, in *Drosophila*, light induces the degradation of the TIM protein, whereas in *Neurospora* light induces the expression of the *frq* gene. As a result of this differential effect of light, the peak in *per* (*tim*) and *frq* mRNA occurs during the dark and the light phases, respectively (see Fig. 2 B,D), in agreement with experimental observations in *Droso-*

*phila* (Qiu and Hardin, 1996) and *Neurospora*. The difference in the effect of light also underlies the distinctive features of the PRCs that yield the phase shifts caused by light pulses in the two organisms (compare the left and right bottom panels of Fig. 5 obtained, respectively, for the *Drosophila* and *Neurospora* models).

The interest of the models is that they allow us to study in detail the relative contribution of the different molecular processes that finally shape the various types of PRCs observed in the experiments. The *Drosophila* model accounts well for the PRCs obtained for light pulses in both the wild type and the *per<sup>s</sup>* mutant when assuming that the light pulse doubles the rate of TIM degradation during 3 h. The PRC for an inhibitor of protein synthesis in *Drosophila* should resemble the light PRCs shown in the left, bottom panel of Fig. 5, because decreased protein synthesis as well as light (which enhances protein degradation) both result in lowering the level of the PER-TIM complex.

The PRC for the perturbation by light in the model for *Neurospora* is shown in the right, bottom panel in Fig. 5. In contrast to the experimental PRC, which is of type 0 (Crosthwaite et al., 1995), the theoretical curve in Fig. 5 is of type 1, although a transition to type 0 can be observed at larger magnitudes of the effect of light on parameter  $v_s$ . Even then, however, a dead zone, not seen in the experimental curve, remains present in the PRC predicted by the model. We are currently investigating the reason for this discrepancy. PRCs for the effect of an inhibitor of protein synthesis have been obtained in the Goodwin model by Ruoff et al. (1999); the effect of such an inhibitor in this organism is somewhat complicated by the fact that it also inhibits the degradation of the FRQ protein.

The model for *Drosophila* allowed us also to account for the suppression of circadian rhythmicity by a critical light pulse delivered at the appropriate phase with the appropriate duration and magnitude, as predicted on general theoretical grounds (Winfree, 1980) and shown for human circadian rhythms (Jewett et al., 1991). The phase of such critical perturbation is not unique: suppression of the rhythm in the model is observed over a portion of the limit cycle, and the duration and magnitude of the successful pulses depend on the phase at which the perturbation is applied. Suppression was achieved by taking into account the molecular effects of the light perturbation, via a transient change in TIM degradation rate.

The models can help to explain why sustained circadian oscillations occur both in DD and (but this is less clear) in LL in *Neurospora* (Crosthwaite et al., 1995;

Garceau et al., 1997), while the oscillations are sustained in DD but damped in LL in *Drosophila* (Qiu and Hardin, 1996). The model for *Drosophila* indeed shows that circadian rhythms occur in a window bounded by two critical bifurcation values of the light-controlled parameter  $v_{dt}$  (Fig. 4B). Thus, if the value of  $v_{dt}$  in the dark lies within the oscillatory domain but goes out of it upon increasing during the light phase, this would explain why oscillations are sustained in DD but not in LL conditions. In contrast, the study of the model for circadian rhythms in *Neurospora* shows that sustained oscillations generally occur above a critical value of the light-controlled parameter  $v_s$ , although for other parameter values the situation may become analogous to that seen in the *Drosophila* model, with the appearance of a second, larger critical value of  $v_s$  providing an upper bound for the oscillatory domain. It is, however, more difficult to obtain damping of the oscillations in constant light in the model for circadian rhythms in *Neurospora* than in the model for *Drosophila*. This difference is likely due to distinct effects of light, which enhances transcription in the former system and protein degradation in the latter.

Another conspicuous property of circadian rhythms is that their period remains largely independent from temperature. As shown by the study of other models (Ruoff and Rensing, 1996) and the model for circadian oscillations of the PER protein (Leloup and Goldbeter, 1997), this property of temperature compensation can in principle arise from the antagonistic effects exerted on the period by the different kinetic parameters of the system. The value of most parameters is expected to increase with temperature. The rise in some parameters results in an increased period while a decreased period results from the rise in other parameters. If these effects roughly counterbalance each other, the period of the rhythm will not change significantly as the temperature changes (Leloup and Goldbeter, 1997).

The model for circadian rhythms in *Drosophila* incorporating the formation of a PER-TIM complex is so far the most detailed in molecular terms. This model accounts for oscillations in the wild type and in several *per* mutants such as *per<sup>l</sup>* and *per<sup>s</sup>* (Leloup and Goldbeter, 1998). Further extensions of this model are presently being studied, to incorporate the possible role of posttranscriptional regulation as well as the role of recently discovered gene products such as the activators CLOCK and CYCLE, which mediate the control exerted by the PER-TIM complex on the expression of the *per* and *tim* genes.

The model for *Neurospora* is less detailed, if only because FRQ does not appear to form a complex with another protein to exert its negative feedback action. In its simple three-variable form obtained when disregarding FRQ phosphorylation, the model is closely related to the model proposed by Goodwin (1965) for oscillations due to negative feedback on gene expression. Ruoff et al. (1999) have recently applied the Goodwin oscillator model to determine the phase-shifting effect of pulses of cycloheximide and heat shock on the *Neurospora* circadian clock. Their study focuses on the effect of inhibitors of protein synthesis and degradation and does not address the control of circadian oscillations by light, which is considered in the present study.

The models show that LD cycles can have different effects on circadian oscillations, depending on the magnitude of the periodic changes in the light-controlled parameter. First, the locking phase of the oscillations was found to depend on this magnitude in the *Neurospora* model (Fig. 3B) more than in the model for *Drosophila* rhythms (Fig. 3A). Second, as the magnitude of the light-induced changes increases, quasi-periodic oscillations, entrainment to the external cycle (Fig. 2 B,D), or aperiodic oscillations in the form of chaos (Fig. 7D) can be observed. These theoretical predictions could be verified experimentally, provided that the light-induced parameter changes required can be achieved in the experiments before saturation occurs in the effects of light.

Chaos has also been found in the extended model for circadian oscillations in *Drosophila* (Leloup and Goldbeter, 1999). Such aperiodic oscillations, however, are autonomous since they occur in this model in constant environmental conditions corresponding to DD, as a result of asymmetries in the values of the biochemical parameters characterizing the two branches of the PER-TIM control system schematized in Fig. 1.

Recent experiments suggest that in *Neurospora*, besides the negative regulation exerted by FRQ on *frq* transcription, other, still uncharacterized biochemical processes might contribute to the occurrence of conidiation rhythmicity. Supporting such a view and pointing to a role for FRQ as a component of an input pathway to the clock are the observations of a conidiation rhythm in some FRQ-deficient mutants (Lakin-Thomas, 1998; Merrow et al., 1999). More information is needed at the molecular level before incorporating such views into models for the *Neurospora* circadian clock.

We focused in the present study on the modeling of circadian rhythms in *Drosophila* and *Neurospora*. Recent experimental observations indicate that the *per* and *tim* gene products are also found in mammals, including man (Tei et al., 1997; Zylka et al., 1998). This strengthens the possibility that the models proposed for *Drosophila* may also hold for circadian rhythms in mammals. In some mammalian species, it appears that the effect of light might nevertheless be close to that seen in *Neurospora*, since light induces the expression of some of the *per* gene homologs in mice.

In addition to the recently characterized genes mentioned above, new clock genes will undoubtedly be uncovered by future experiments. Such new players will have to be included as additional variables or parameters in molecular models for circadian rhythms. These extensions will be required to accommodate the new experimental findings and to assess in detail the relative contribution of each factor involved in the circadian oscillatory mechanism. From a qualitative viewpoint, it is likely, however, that the results of such extended models will largely remain unchanged, since limit cycle oscillations are necessarily associated (in the appropriate parameter range) with the autoregulatory negative feedback on gene expression found in prototypic organisms such as *Neurospora* and *Drosophila*.

## ACKNOWLEDGMENTS

This work was supported by the program Actions de Recherche Concertée (ARC 94-99/180) launched by the Division of Scientific Research, Ministry of Science and Education, French Community of Belgium. J.-C. Leloup holds a research fellowship from F.R.I.A.

## REFERENCES

- Allada R, White NE, So WV, Hall JC, and Rosbash M (1998) A mutant *Drosophila* homolog of mammalian *clock* disrupts circadian rhythms and transcription of *period* and *timeless*. *Cell* 93:791-804.
- Cheng Y and Hardin PE (1998) *Drosophila* photoreceptors contain an autonomous circadian oscillator that can function without *period* mRNA cycling. *J Neurosci* 18:741-750.
- Crosthwaite SK, Dunlap JC, and Loros JJ (1997) *Neurospora wc-1* and *wc-2*: Transcription, photoresponses, and the origins of circadian rhythmicity. *Science* 276:763-769.

- Crosthwaite SK, Loros JJ, and Dunlap JC (1995) Light-induced resetting of a circadian clock is mediated by a rapid increase in *frequency* transcript. *Cell* 81:1003-1012.
- Curtin KD, Huang ZI, and Rosbash M (1995) Temporally regulated nuclear entry of the *Drosophila* period protein contributes to the circadian clock. *Neuron* 14:365-372.
- Darlington TK, Wager-Smith K, Ceriani MF, Staknis D, Gekakis N, Steeves TDL, Weitz CJ, Takahashi JS, and Kay SA (1998) Closing the circadian loop: CLOCK-induced transcription of its own inhibitors *per* and *tim*. *Science* 280:1599-1603.
- Drescher K, Cornelius G, and Rensing L (1982) Phase response curves obtained by perturbing different variables of a 24 hr model oscillator based on translational control. *J Theor Biol* 94:345-53.
- Dunlap JC (1998) Common threads in eukaryotic circadian systems. *Curr Opin Genet Dev* 8:400-406.
- Edey I, Zwiebel LJ, Dembinska ME, and Rosbash M (1994) Temporal phosphorylation of the *Drosophila period* protein. *Proc Natl Acad Sci USA* 91:2260-2264.
- Garceau NY, Liu Y, Loros JJ, and Dunlap JC (1997) Alternative initiation of translation and time-specific phosphorylation yield multiple forms of the essential clock protein FREQUENCY. *Cell* 89:469-476.
- Goldbeter A (1995) A model for circadian oscillations in the *Drosophila period* (PER) protein. *Proc R Soc Lond B* 261:319-324.
- Goldbeter A (1996) *Biochemical Oscillations and Cellular Rhythms: The Molecular Bases of Periodic and Chaotic Behaviour*, Cambridge University Press, Cambridge, UK.
- Gonze D, Leloup J-C, and Goldbeter A (1999) Theoretical models for circadian rhythms in *Neurospora* and *Drosophila*. *C R Acad Sci III* (in press).
- Goodwin BC (1965) Oscillatory behavior in enzymatic control processes. *Adv Enzyme Regul* 3:425-438.
- Hall JC and Rosbash M (1987) Genes and biological rhythms. *Trends Genet* 3:185-191.
- Jewett ME and Kronauer RE (1998) Refinement of a limit cycle oscillator model of the effects of light on the human circadian pacemaker. *J Theor Biol* 192:455-465.
- Jewett ME, Kronauer RE, and Czeisler CA (1991) Light-induced suppression of endogenous circadian amplitude in humans. *Nature* 350:59-62.
- Kalmus H and Wigglesworth LA (1960) Shock excited systems as models for biological rhythms. *Cold Spring Harb Symp Quant Biol* 25:211-216.
- Konopka RJ and Benzer S (1971) Clock mutants of *Drosophila melanogaster*. *Proc Natl Acad Sci USA* 68:2112-2116.
- Lakin-Thomas P (1998) Choline depletion, *frq* mutations, and temperature compensation of the circadian rhythm in *Neurospora crassa*. *J Biol Rhythms* 13:268-277.
- Leloup J-C and Goldbeter A (1997) Temperature compensation of circadian rhythms: Control of the period in a model for circadian oscillations of the PER protein in *Drosophila*. *Chronobiol Int* 14:511-520.
- Leloup J-C and Goldbeter A (1998) A model for circadian rhythms in *Drosophila* incorporating the formation of a complex between the PER and TIM proteins. *J Biol Rhythms* 13:70-87.
- Leloup J-C and Goldbeter A (1999) Chaos and birhythmicity in a model for circadian oscillations of the PER and TIM proteins in *Drosophila*. *J Theor Biol* 198:445-459.
- Luo C, Loros JJ, and Dunlap JC (1998) Nuclear localization is required for function of the essential clock protein FRQ. *EMBO J* 17:1228-1235.
- Merrow M, Brunner M, and Roenneberg T (1999) Assignment of circadian function for the *Neurospora* clock gene *frequency*. *Nature* 399:584-586.
- Pavlidis T (1973) *Biological Oscillators: Their Mathematical Analysis*, Academic Press, New York.
- Peterson EL (1980) A limit cycle interpretation of a mosquito circadian oscillator. *J Theor Biol* 84:281-310.
- Qiu J and Hardin PE (1996) *per* mRNA cycling is locked to lights-off under photoperiodic conditions that support circadian feedback loop function. *Mol Cell Biol* 16:4182-4188.
- Rosbash M (1995) Molecular control of circadian rhythms. *Curr Opin Gen Dev* 5:662-668.
- Ruoff P and Rensing L (1996) The temperature-compensated Goodwin model simulates many circadian clock properties. *J Theor Biol* 179:275-285.
- Ruoff P, Vinsjevnik M, Mohsenzadeh S, and Rensing L (1999) The Goodwin model: Simulating the effect of cycloheximide and heat shock on the sporulation rhythm of *Neurospora crassa*. *J Theor Biol* 196:483-494.
- Rutila JE, Suri V, Le M, So WV, Rosbash M, and Hall JC (1998) CYCLE is a second bHLH-PAS clock protein essential for circadian rhythmicity and transcription of *Drosophila period* and *timeless*. *Cell* 93:805-814.
- So WV and Rosbash M (1997) Post-transcriptional regulation contributes to *Drosophila* clock gene mRNA cycling. *EMBO J* 16:7146-7155.
- Tei H, Okamura H, Shigeyoshi Y, Fukuhara C, Ozawa R, Hirose M, and Sakaki Y (1997) Circadian oscillation of a mammalian homologue of the *Drosophila period* gene. *Nature* 389:512-516.
- Wever RA (1972) Virtual synchronization towards the limits of the range of entrainment. *J Theor Biol* 36:119-132.
- Winfree AT (1980) *The Geometry of Biological Time*. Springer, New York.
- Zeng H, Qian Z, Myers MP, and Rosbash M (1996) A light-entrainment mechanism for the *Drosophila* circadian clock. *Nature* 380:129-135.
- Zylka MJ, Shearman LP, Levine JD, Jin X, Weaver DR, and Reppert SM (1998) Molecular analysis of mammalian timeless. *Neuron* 21:1115-1122.