

University of Groningen

## Linear Passive Networks With Ideal Switches

Frasca, Roberto; Camlibel, M. Kanat; Goknar, I. Cem; Iannelli, Luigi; Vasca, Francesco

*Published in:*  
IEEE Transactions on Circuits and Systems I - Regular papers

*DOI:*  
[10.1109/TCSI.2010.2052511](https://doi.org/10.1109/TCSI.2010.2052511)

**IMPORTANT NOTE: You are advised to consult the publisher's version (publisher's PDF) if you wish to cite from it. Please check the document version below.**

*Document Version*  
Publisher's PDF, also known as Version of record

*Publication date:*  
2010

[Link to publication in University of Groningen/UMCG research database](#)

*Citation for published version (APA):*

Frasca, R., Camlibel, M. K., Goknar, I. C., Iannelli, L., & Vasca, F. (2010). Linear Passive Networks With Ideal Switches: Consistent Initial Conditions and State Discontinuities. *IEEE Transactions on Circuits and Systems I - Regular papers*, 57(12), 3138-3151. <https://doi.org/10.1109/TCSI.2010.2052511>

### Copyright

Other than for strictly personal use, it is not permitted to download or to forward/distribute the text or part of it without the consent of the author(s) and/or copyright holder(s), unless the work is under an open content license (like Creative Commons).

The publication may also be distributed here under the terms of Article 25fa of the Dutch Copyright Act, indicated by the "Taverne" license. More information can be found on the University of Groningen website: <https://www.rug.nl/library/open-access/self-archiving-pure/taverne-amendment>.

### Take-down policy

If you believe that this document breaches copyright please contact us providing details, and we will remove access to the work immediately and investigate your claim.

*Downloaded from the University of Groningen/UMCG research database (Pure): <http://www.rug.nl/research/portal>. For technical reasons the number of authors shown on this cover page is limited to 10 maximum.*

# Linear Passive Networks With Ideal Switches: Consistent Initial Conditions and State Discontinuities

Roberto Frasca, M. Kanat Camlibel, *Member, IEEE*, I. Cem Goknar, *Fellow, IEEE*, Luigi Iannelli, *Member, IEEE*, and Francesco Vasca, *Member, IEEE*

**Abstract**—This paper studies linear passive electrical networks with ideal switches. We employ the so-called linear switched systems framework in which these circuits can be analyzed for any given switch configuration. After providing a complete characterization of admissible inputs and consistent initial states with respect to a switch configuration, the paper introduces a new state reinitialization rule that is based on energy minimization at the time of switching. This new rule is proven to be equivalent to the classical methods of Laplace transform and charge/flux conservation principle. Also we illustrate the new rule on typical examples that have been treated in the literature.

**Index Terms**—Consistent initial conditions, energy-based jump rule, state discontinuities, state jump, switched networks.

## I. INTRODUCTION

SWITCHING circuits are encountered in various applications from power converters to signal processing. To simplify the analysis, the switching elements are typically taken as ideal elements. Such ideal switching behavior may cause discontinuities in the state variables (typically voltages across capacitors and currents through inductors). A good deal of literature on switched networks has been devoted to the problem of state *reinitialization*, i.e., determining the state after a discontinuity. The main goal of this paper is to study the state reinitialization problem for electrical networks consisting of linear passive elements, independent voltage/current sources, and ideal switches.

For an account of previous work in the literature, we give the following inevitably incomplete survey of related work within the area of circuit theory. In the classical book [1], state reinitialization problem has been addressed by utilizing the charge/flux conservation principle. A general formalization of this conservation principle has not been given; it has been explained only through examples. A set of algebraic equations was obtained in [2] for reinitialization of active RLC circuits. In case of a passive network, the method reduces to the application of charge/flux conservation principle. In [3], the principle of charge/flux conservation has been applied to periodically operated switched networks for state reinitialization problem. In [4], the authors proposed a reinitialization method that is based

on numerical inversion of Laplace transform. Their method obtains consistent initial states in two steps: one step forward in time to overcome the impulse and one step backward to the switching instant. Reference [5] uses also the Laplace transform method for reinitialization. This line of work has been extended in [6] to periodically switched nonlinear circuits. Other papers that took numerical approaches include [7]–[9]. The distributional framework has been used in [10] where current sources were excluded, in [11] an approach to calculate the energy loss after the discontinuity was developed. Other related work consists of generalizations to nonlinear setting (e.g., [12]–[15]) and calculation and interpretation of energy loss in switching instants (e.g., [16]–[18]). For internally controlled switching elements, state reinitialization was considered in [19]–[22]. Also state discontinuities were discussed in the context of switched capacitor circuits in [23], [24], in the context of robust stabilization of complex switched networks in [25], and in the context of steady-state analysis of nonlinear circuits containing ideal switches in [26]. In the literature, switched networks have been almost always treated by fixing a switch configuration and deriving the differential algebraic equations that govern the network. In order to analyze the same circuit for another switch configuration, a typical approach consists of deriving the corresponding circuit equations for the new configuration (see, e.g., [8]). In our work, we employ the so-called *linear switched systems* framework (see, e.g., [21], [27]) that allows one to obtain circuit equations for any switch configuration in a natural way. Within this framework, we assume that the network elements other than the ideal switches and sources are linear and passive. Based on this assumption, we give a complete characterization (for any given switch configuration) of *admissible inputs* (voltage/current sources), i.e., sources that are acceptable and *consistent initial states*, i.e., initial states that do not cause discontinuities in the state variable. After that, we study the *inconsistent initial states*, i.e., initial states that cause discontinuities. First, we introduce an *energy-based jump rule* for determining the state after a jump occurs. The novelty of this new rule stems from its conceptual insight and computational simplicity. Finally, the other two alternative methods for determining the state after discontinuity, namely Laplace transform method and charge/flux conservation principle have been investigated. We show that these two methods are equivalent to the new energy-based jump rule.

The structure of the paper is as follows. After introducing the notational conventions in Section II, we begin with setting a general framework for *linear switched systems* in Section III. This is followed by a quick review of the notion of passivity in Section IV. In Section V, a complete characterization of admissible inputs and consistent initial states is presented. For the inconsistent states, we introduce an energy-based jump rule and show its equivalence to charge/flux conservation principle as

Manuscript received July 29, 2009; revised January 09, 2010 and March 24, 2010; accepted April 24, 2010. Date of publication August 03, 2010; date of current version December 15, 2010. This paper was recommended by Associate Editor E. Alarcon.

R. Frasca, L. Iannelli, and F. Vasca are with the Department of Engineering, University of Sannio, Benevento, Italy (e-mail: frasca@unisannio.it; luigi.iannelli@unisannio.it; vasca@unisannio.it).

M. K. Camlibel is with the Johan Bernoulli Institute of Mathematics and Computer Science, University of Groningen, The Netherlands. He is also with the Department of Electronics and Communications Engineering, Dogus University, Istanbul, Turkey (e-mail: m.k.camlibel@rug.nl).

I. C. Goknar is with the Department of Electronics and Communications Engineering, Dogus University, Istanbul, Turkey (e-mail: cgoknar@dogus.edu.tr).

Digital Object Identifier 10.1109/TCSI.2010.2052511

well as Laplace transformation based jump rule in Section VI. After illustrating the new jump rule with several examples in Section VII, the paper closes with conclusions in Section VIII and proofs in Appendix A.

## II. PRELIMINARIES

Throughout the paper, the following notational conventions will be in force.

We denote the real numbers by  $\mathbb{R}$  and complex numbers by  $\mathbb{C}$ . The transpose of a matrix  $A$  is denoted by  $A^T$  and Hermitian by  $A^H$ . For a square invertible matrix, we write  $A^{-1}$  to denote its inverse. For a (possibly nonsquare) matrix  $A$ , the notation  $A^\dagger$  denotes the so-called Moore–Penrose pseudoinverse. For two matrices  $A$  and  $B$  with the same number columns,  $\text{col}(A, B)$  denotes the matrix obtained by stacking  $A$  over  $B$ . A square matrix  $M \in \mathbb{R}^{n \times n}$  is positive semidefinite if  $x^T M x \geq 0$ ; in this case, we write  $M \geq 0$ . It is positive definite if it is positive semidefinite and  $x^T M x = 0$  implies  $x = 0$ ; in this case, we write  $M > 0$ . Associated with a matrix  $M \in \mathbb{R}^{m \times n}$ , we define  $\ker M = \{x \in \mathbb{R}^n | Mx = 0\}$  and  $\text{im } M = \{y \in \mathbb{R}^m | y = Mx \text{ for some } x \in \mathbb{R}^n\}$ .

The notations  $\dot{x}$  and  $(d/dt)x$  denote the derivative of the function  $x : \mathbb{R} \rightarrow \mathbb{R}^n$ . We say that a function  $f$  is a *Bohl function* if there are matrices  $F$ ,  $G$ , and  $H$  with suitable sizes such that  $f(t) = H \exp(Ft)G$  for  $t \geq 0$ . Note that Bohl functions consist of polynomials, sinusoids, exponentials, and finite sums and products of these.

A pair of matrices  $(A, B) \in \mathbb{R}^{n \times n} \times \mathbb{R}^{n \times m}$  is said to be controllable if  $\text{rank}([B \ AB \ \dots \ A^{n-1}B]) = n$ . A pair of matrices  $(C, A) \in \mathbb{R}^{m \times n} \times \mathbb{R}^{n \times n}$  is said to be observable if  $(A^T, C^T)$  is controllable. A triple of matrices  $(A, B, C) \in \mathbb{R}^{n \times n} \times \mathbb{R}^{n \times m} \times \mathbb{R}^{m \times n}$  is minimal if  $(A, B)$  is controllable and  $(C, A)$  is observable.

The Laplace transform of a signal  $x(t)$  is denoted by  $\hat{x}(s)$ . We say that a rational function  $\hat{x}(s)$  is proper if the limit  $\lim_{s \rightarrow \infty} \hat{x}(s)$  exists and strictly proper if  $\lim_{s \rightarrow \infty} \hat{x}(s) = 0$ . We use the same terminology for vectors and matrices, meaning that each element has the required property.

## III. LINEAR SWITCHED SYSTEMS

In this section, we first introduce the linear switched system framework. This framework provides a compact representation of switched systems as it enables us to analyze the behavior of the system under any switching topology. After introducing this framework, we formalize the switch configuration and the solution concept we work with. We also define admissible inputs and consistent initial states for a given switch configuration. All these concepts/definitions are illustrated by examples.

Consider the systems of the form

$$\dot{x}(t) = Ax(t) + Bz(t) + Eu(t) \quad (1a)$$

$$w(t) = Cx(t) + Dz(t) + Fu(t) \quad (1b)$$

where  $x \in \mathbb{R}^n$  is the state,<sup>1</sup>  $u \in \mathbb{R}^p$  is the input, and  $(z, w) \in \mathbb{R}^{m+m}$  are *ideal switch variables*, i.e.,

$$\text{either } z_i(t) = 0 \text{ or } w_i(t) = 0 \quad (1c)$$

<sup>1</sup>The variable  $x$  is called state by abuse of terminology as depending on the switch configuration a subset of the variables will qualify as true state variables. Sometimes,  $x$  is referred to as semistate variables or candidates for state variables in the literature.

for each time instant  $t \geq 0$ . We call these systems *linear switched systems* (LSS).

This class of systems naturally appears in the context of linear electrical networks with ideal switches. Given such a network, one can first extract the switches to the ports. Then, the dynamics of the remaining circuit that contains linear circuit elements and sources (under the assumption that the resulting circuit has the proper hybrid description) can be described by the state-space form (1a), (1b) where the voltage–current pairs of the switches correspond to the external variables  $(z, w)$ , the voltage–current sources correspond to the inputs  $u$ , and the state variables are, for instance, voltages across the capacitors and the currents through inductors. The relations (1c) correspond to the constitutive laws for ideal switches. A detailed description of a possible construction procedure of the model (1) for electrical networks is given in Section VI-D1.

The typical frameworks in the study of switched systems focus on a given switch configuration and work on the governing equations of the circuit that is only valid for this configuration (see, e.g., [8], [10], [19]). Analysis of another configuration requires obtaining the governing equations for the new switch configuration. The LSS model (1), however, provides a compact representation which captures the dynamics of any possible switch configuration. Once the switch configuration is specified, one can obtain the governing equations directly from the general LSS description by deleting corresponding columns of  $B$  and  $D$  matrices, and rows of  $C$  and  $D$  matrices. In what follows we elaborate on switch configurations and the dynamics for a fixed switch configuration.

An issue of particular interest is the behavior of the network under different switch configurations. We say that LSS (1) is in the *switch configuration*  $\pi \subseteq \{1, 2, \dots, m\}$  on some interval of time if

$$w_i(t) = 0 \quad \text{if } i \in \pi \quad (2a)$$

$$z_i(t) = 0 \quad \text{if } i \notin \pi \quad (2b)$$

for all time instants  $t$  in the same interval.

*Example III.1:* Consider the circuit shown in Fig. 1. This circuit can be obtained from the classical Buck converter topology by replacing the diode with an ideal switch ( $S_2$ ). Suppose that the resistor, the capacitor, and the inductor are all linear elements. A possible LSS description (see Example VI.7) can be obtained as follows:

$$\begin{aligned} \dot{x}(t) = & \begin{bmatrix} -\frac{1}{RC} & -\frac{1}{C} \\ \frac{1}{L} & 0 \end{bmatrix} x(t) + \begin{bmatrix} 0 & 0 \\ -\frac{1}{L} & 0 \end{bmatrix} z(t) \\ & + \begin{bmatrix} 0 \\ 0 \end{bmatrix} v_E(t) \end{aligned} \quad (3a)$$

$$\begin{aligned} w(t) = & \begin{bmatrix} 0 & -1 \\ 0 & 0 \end{bmatrix} x(t) + \begin{bmatrix} 0 & 1 \\ -1 & 0 \end{bmatrix} z(t) \\ & + \begin{bmatrix} 0 \\ 1 \end{bmatrix} v_E(t) \end{aligned} \quad (3b)$$

$$\text{either } z_i(t) = 0 \text{ or } w_i(t) = 0 \quad (3c)$$

where  $x = \text{col}(v_C, i_L)$ ,  $z = \text{col}(v_{S_2}, i_{S_1})$  and  $w = \text{col}(i_{S_2}, v_{S_1})$ . As the circuit contains two switches, there are four possible switch configurations, shown in the equation at the bottom of the next page.

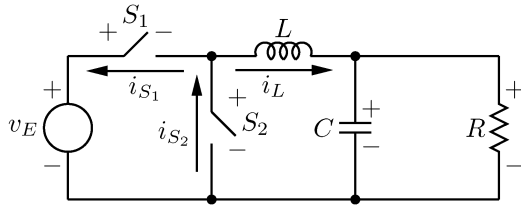

Fig. 1. Buck converter.

### A. Dynamics in a Switch Configuration

Given a fixed switch configuration  $\pi \subseteq \{1, 2, \dots, m\}$ , the dynamics of the LSS (1) is given by the differential-algebraic equations (DAEs)

$$\dot{x}(t) = Ax(t) + B_{\bullet\pi}z_\pi(t) + Eu(t) \quad (4a)$$

$$z_{\pi^c}(t) = 0 \quad (4b)$$

$$0 = w_\pi(t) = C_{\pi\bullet}x(t) + D_{\pi\pi}z_\pi(t) + F_{\pi\bullet}u(t) \quad (4c)$$

$$w_{\pi^c}(t) = C_{\pi^c\bullet}x(t) + F_{\pi^c\bullet}u(t) \quad (4d)$$

where the complement of  $\pi$  is denoted by  $\pi^c$ , that is  $\pi^c = \{1, 2, \dots, m\} \setminus \pi$ . Here, we use the notation  $v_\alpha$  where  $\alpha \subseteq \{1, 2, \dots, q\}$  to denote the elements of  $v \in \mathbb{R}^q$  that are indexed by the set  $\alpha$  and  $V_{\alpha\beta}$  where  $\alpha \subseteq \{1, 2, \dots, q\}$ ,  $\beta \subseteq \{1, 2, \dots, r\}$  to denote the submatrix obtained from  $V \in \mathbb{R}^{q \times r}$  by taking the rows indexed by  $\alpha$  and the columns indexed by  $\beta$ . Also, we denote  $V_{\alpha\beta}$  with  $\beta = \{1, 2, \dots, r\}$  by  $V_{\alpha\bullet}$  and  $V_{\alpha\beta}$  with  $\alpha = \{1, 2, \dots, q\}$  by  $V_{\bullet\beta}$ .

### B. Solution Concept

In what follows we define what we mean by a ‘‘solution’’ to the (4). To avoid certain technicalities that would blur the main message of the paper, we deal only with Bohl-type inputs (i.e., polynomials, sinusoids, exponentials, and finite sums and products of these) in the sequel.

**Definition III.2:** We say that:

- a continuously differentiable function  $x$  is a *solution* with respect to the switch configuration  $\pi$  for the initial state  $x_0$  and the input  $u$  if the DAEs (4) are satisfied for all  $t \geq 0$  and  $x(0) = x_0$ ;
- an input  $u$  is *admissible* with respect to the switch configuration  $\pi$  if the DAEs (4) admit a solution at least for an initial state  $x_0$ ;
- an initial state  $x_0$  is *consistent* with respect to the switch configuration  $\pi$  and the admissible input  $u$  if the DAEs (4) admit a solution.

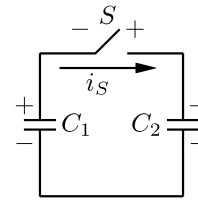

Fig. 2. Two capacitors.

Two examples that illustrate the concepts of admissibility and consistency are in order.

**Example III.3:** Consider the Buck converter of Example III.1 and suppose that both switches are closed, i.e., the switch configuration is given by  $\pi = \{2\}$ . Now  $z_\pi = i_{S_1}$  and the dynamics are governed by the following DAEs:

$$\frac{d}{dt} \begin{bmatrix} v_C \\ i_L \end{bmatrix} = \begin{bmatrix} -\frac{1}{RC} & -\frac{1}{C} \\ \frac{1}{L} & 0 \end{bmatrix} \begin{bmatrix} v_C \\ i_L \end{bmatrix} + \begin{bmatrix} 0 \\ 0 \end{bmatrix} i_{S_1} + \begin{bmatrix} 0 \\ 0 \end{bmatrix} v_E \quad (5a)$$

$$0 = \begin{bmatrix} 0 & 0 \end{bmatrix} \begin{bmatrix} v_C \\ i_L \end{bmatrix} + v_E. \quad (5b)$$

Equation (5b) imposes a constraint on the input, namely  $v_E = 0$ . As such the only admissible input with respect to this switch configuration is the zero input.

**Example III.4:** Consider the circuit depicted in Fig. 2. It can be put in the LSS form as follows:

$$\frac{d}{dt} \begin{bmatrix} v_{C_1} \\ v_{C_2} \end{bmatrix} = \begin{bmatrix} 0 & 0 \\ 0 & 0 \end{bmatrix} \begin{bmatrix} v_{C_1} \\ v_{C_2} \end{bmatrix} + \begin{bmatrix} -\frac{1}{C_1} \\ \frac{1}{C_2} \end{bmatrix} i_S \quad (6a)$$

$$v_S = \begin{bmatrix} -1 & 1 \end{bmatrix} \begin{bmatrix} v_{C_1} \\ v_{C_2} \end{bmatrix} \quad (6a)$$

$$\text{either } i_S = 0 \text{ or } v_S = 0. \quad (6c)$$

Suppose that the switch configuration  $\pi = \{1\}$ , i.e., the switch is closed. For this configuration, the DAEs (4) are given by

$$\frac{d}{dt} \begin{bmatrix} v_{C_1} \\ v_{C_2} \end{bmatrix} = \begin{bmatrix} 0 & 0 \\ 0 & 0 \end{bmatrix} \begin{bmatrix} v_{C_1} \\ v_{C_2} \end{bmatrix} + \begin{bmatrix} -\frac{1}{C_1} \\ \frac{1}{C_2} \end{bmatrix} i_S \quad (7a)$$

$$0 = \begin{bmatrix} -1 & 1 \end{bmatrix} \begin{bmatrix} v_{C_1} \\ v_{C_2} \end{bmatrix}. \quad (7b)$$

The algebraic equation (7b) implies that an initial state is consistent if and only if  $v_{C_1}(0) = v_{C_2}(0)$ . Note that given a consistent initial state  $v_{C_1}(0) = v_{C_2}(0)$  the DAEs (7) admit the unique solution  $v_{C_1}(t) = v_{C_2}(t) = v_{C_1}(0)$  for all  $t \geq 0$ .

Our first aim is to give a complete characterization of admissible inputs and consistent initial states for a given circuit and

$S_1$	$S_2$	conditions	switch configuration
open	open	$i_{S_1} = 0$ and $i_{S_2} = 0$	$\pi = \{1\}$
open	closed	$i_{S_1} = 0$ and $v_{S_2} = 0$	$\pi = \emptyset$
closed	open	$v_{S_1} = 0$ and $i_{S_2} = 0$	$\pi = \{1, 2\}$
closed	closed	$v_{S_1} = 0$ and $v_{S_2} = 0$	$\pi = \{2\}$

switch configuration. For this, we will work in the framework of LSS (1) and exploit the passivity of the underlying linear system. Next, we summarize the notion of passivity.

#### IV. PASSIVITY

This section is devoted to the notions of passivity and positive realness. We quickly review the definition of passivity and its relation to positive realness as well as the implications of passivity that will be used throughout the paper.

Having roots in circuit theory, passivity is a concept that has always played a central role in systems theory. Roughly speaking, a system is passive if the increase in the stored energy does not exceed the supplied energy.

*Definition IV.1 [28]:* A linear system  $\Sigma(A, B, C, D)$  given by

$$\dot{x}(t) = Ax(t) + Bz(t) \quad (8a)$$

$$w(t) = Cx(t) + Dz(t) \quad (8b)$$

is called *passive* if there exists a nonnegative-valued function  $V : \mathbb{R}^n \rightarrow \mathbb{R}_+$  such that for all  $t_0 \leq t_1$  and all trajectories  $(z, x, w)$  of the system (8) the following inequality holds:

$$V(x(t_0)) + \int_{t_0}^{t_1} z^T(t)w(t)dt \geq V(x(t_1)). \quad (9)$$

If it exists the function  $V$  is called a *storage function*.

An intimately related concept to passivity is positive realness.

*Definition IV.2:* A rational matrix  $G(s) \in \mathbb{R}^{m \times m}(s)$  is positive real if

- $G$  is analytic in  $\mathbb{C}_+$ ;
- $G(s) + G^H(s) \geq 0$  for all  $s \in \mathbb{C}_+$ .

Here  $\mathbb{C}_+$  denotes the open right halfplane in  $\mathbb{C}$ .

The relation between passivity and positive realness is known as the Kalman–Yakubovich–Popov lemma. The following proposition states this relation together with some other well-known implications of passivity.

*Proposition IV.3 [28]:* Consider the following statements.

- 1) The system  $\Sigma(A, B, C, D)$  is passive.
- 2) The linear matrix inequalities (LMIs)

$$K = K^T \geq 0 \text{ and } \begin{bmatrix} A^T K + KA & KB - C^T \\ B^T K - C & -(D + D^T) \end{bmatrix} \leq 0 \quad (10)$$

have a solution  $K$ .

- 3) The function  $V(x) = (1/2)x^T Kx$  defines a storage function.
- 4) The transfer matrix  $D + C(sI - A)^{-1}B$  is positive real.
- 5) The triple  $(A, B, C)$  is minimal.
- 6) The pair  $(C, A)$  is observable.
- 7) The matrix  $K$  is positive definite.

The following implications hold.

- A)  $1 \Leftrightarrow 2 \Leftrightarrow 3$ .
- B)  $2 \Rightarrow 4$ .
- C)  $4$  and  $5 \Rightarrow 2$ .
- D)  $2$  and  $6 \Rightarrow 7$ .

#### V. A COMPLETE CHARACTERIZATION OF ADMISSIBLE INPUTS AND CONSISTENT INITIAL STATES

The purpose of this section is to give a complete characterization of admissible inputs and consistent states. The two main

ingredients are the LSS framework and the notion of passivity that are discussed in the previous sections.

Note that the Laplace transform is a bijection between Bohl functions and strictly proper rational functions. By employing this correspondence, one can treat the DAEs (4) in the Laplace domain. This formulation, together with the passivity property, leads to the following complete characterization of admissible inputs and consistent initial states.

*Theorem V.1:* Consider the LSS (1). Suppose that the system  $\Sigma(A, B, C, D)$  is passive with a positive definite storage function. Then the following statements hold.

- 1) An input  $u$  is admissible with respect to the switch configuration  $\pi$  if and only if

$$F_{\pi\bullet}u(t) \in \text{im}[C_{\pi\bullet} \ D_{\pi\pi}] \text{ for all } t \geq 0. \quad (11)$$

- 2) An initial state  $x_0$  is consistent with respect to the switch configuration  $\pi$  and the admissible Bohl-type input  $u$  if and only if

$$C_{\pi\bullet}x_0 + F_{\pi\bullet}u(0) \in \text{im } D_{\pi\pi}. \quad (12)$$

*Remark V.2:* Theorem V.1 generalizes the results of [21], [27] in two respects: it allows presence of inputs and it does neither assume minimality of the triple nor injectivity of  $\text{col}(B, D + D^T)$ . Note that the latter assumption does not hold in many examples that appear in practice, see, e.g., Examples III.1 and VII.5.

*Remark V.3:* Consider the network of Example III.1 with the switch configuration  $\pi = \{2\}$ . Note that  $C_{\pi\bullet} = 0$ ,  $D_{\pi\pi} = 0$ , and  $F_{\pi\bullet} = 1$ . As such, the condition (11) states that the only admissible input for this configuration is  $v_E = 0$ .

*Remark V.4:* Consider the network in Example III.4. Since the corresponding  $F$  matrix is zero, all inputs are admissible for all configurations. Consider the switch configuration  $\pi = \{1\}$ . Note that  $C_{\pi\bullet} = [-1 \ 1]$ ,  $D_{\pi\pi} = 0$ , and  $F_{\pi\bullet} = 0$ . By applying condition (12), we see that the initial state is consistent if and only if  $v_{C_1}(0) = v_{C_2}(0)$ . Note that if  $\pi = \emptyset$  (i.e., the switch is open), condition (12) drops out and all initial states are consistent.

#### VI. INCONSISTENT INITIAL STATES

Having established complete characterization of consistent initial states, we focus on inconsistent initial states in this section. First, we begin with the well-known example of two capacitors. This is followed by the introduction of the so-called energy-based jump rule which is one of the main contributions of the paper. Finally, we show the equivalence of this new rule to those of the Laplace transform based method and the charge/flux conservation based method.

Consider the circuit given in Example III.4. When the switch is closed, the initial state  $(v_{C_1}(0^-), v_{C_2}(0^-))$  is consistent only if  $v_{C_1}(0^-) = v_{C_2}(0^-)$ . Otherwise one should expect an instantaneous jump in the state so that  $v_{C_1}(0^+) = v_{C_2}(0^+)$ . The standard ways of computing this jump is to employ charge/flux conservation principle or Laplace transform method.

In this very simple example, the former method yields

$$C_1 v_{C_1}(0^-) + C_2 v_{C_2}(0^-) = C_1 v_{C_1}(0^+) + C_2 v_{C_2}(0^+) \quad (13a)$$

$$v_{C_1}(0^+) = v_{C_2}(0^+). \quad (13b)$$

Hence, we get

$$v_{C_1}(0^+) = v_{C_2}(0^+) = \frac{C_1 v_{C_1}(0^-) + C_2 v_{C_2}(0^-)}{C_1 + C_2}. \quad (13c)$$

For the Laplace transform method, one has to solve the algebraic relations obtained by taking the Laplace transform of (6). This would result in

$$\begin{bmatrix} \hat{v}_{C_1}(s) \\ \hat{v}_{C_2}(s) \end{bmatrix} = s^{-1} \begin{bmatrix} \frac{C_1 v_{C_1}(0^-) + C_2 v_{C_2}(0^-)}{C_1 + C_2} \\ \frac{C_1 v_{C_1}(0^-) + C_2 v_{C_2}(0^-)}{C_1 + C_2} \end{bmatrix} \quad (14)$$

and hence (13c) by the initial value theorem of Laplace transform. Although the Laplace transform method yields the same results it may not be preferable for complex networks as it necessitates symbolic manipulations.

In what follows, we propose a novel approach for the computation of the state jump. This new approach is based on the stored energy of the system and gives an explicit formula for the state after the jump in terms of the LSS form (1) and the chosen switch configuration. Its main advantages are to reduce the required computational power significantly and to provide further insight to state discontinuities caused by switching.

Later, we will show that the new jump rule is equivalent to charge/flux conservation rule, as well as the Laplace transform method, for linear passive electrical networks.

#### A. Energy-Based Jump Rule

Inspired by the jump rules that are employed in the context of mechanical systems with unilateral constraints (see [29]–[31]) and of electrical networks with switching elements (see [21], [27], [32]), we introduce an energy-based jump rule in what follows.

*Theorem VI.1:* Consider the LSS (1). Suppose that  $\Sigma(A, B, C, D)$  is passive with a positive definite storage function. Let  $x_0 \in \mathbb{R}^n$  be an initial state,  $\pi \subseteq \{1, 2, \dots, m\}$  be a switch configuration, and  $u$  be an admissible Bohl-type input with respect to the switch configuration  $\pi$ . Consider the minimization problem

$$\text{minimize } \frac{1}{2}(x^+ - x_0)^T K(x^+ - x_0) \quad (15a)$$

$$\text{subject to } C_{\pi\bullet}x^+ + F_{\pi\bullet}u(0) \in \text{im } D_{\pi\pi}. \quad (15b)$$

Then, the following statements hold.

- 1) For any positive definite solution  $K$  of the LMIs (10), the quadratic program (15) has a unique solution.
- 2) The unique solution of (15),  $x_K^+$ , can be explicitly given by

$$x_K^+ = x_0 - K^{-1}C_{\pi\bullet}^T P^T (PC_{\pi\bullet}K^{-1}C_{\pi\bullet}^T P^T)^\dagger P \times (C_{\pi\bullet}x_0 + F_{\pi\bullet}u(0)) \quad (16)$$

where  $P$  is a matrix with appropriate dimensions such that  $\ker P = \text{im } D_{\pi\pi}$ . Moreover,  $x_K^+$  is the solution of (15) if and only if

$$x_K^+ - x_0 \in B_{\pi\bullet} \ker D_{\pi\pi} \quad (17a)$$

$$C_{\pi\bullet}x_K^+ + F_{\pi\bullet}u(0) \in \text{im } D_{\pi\pi}. \quad (17b)$$

- 3) If  $K_1$  and  $K_2$  are two positive definite solutions of the LMIs (10), then  $x_{K_1}^+ = x_{K_2}^+$ .

We define the unique value obtained by the above minimization problem as the *reinitialized state* for the energy-based jump rule and denote it by  $x_E^+$ . Note that if  $x_0$  is a consistent initial state with respect to an admissible Bohl-type input  $u$ , i.e.,  $C_{\pi\bullet}x_0 + F_{\pi\bullet}u(0) \in \text{im } D_{\pi\pi}$ , then  $P(C_{\pi\bullet}x_0 + F_{\pi\bullet}u(0)) = 0$ , and hence  $x_E^+ = x_0$ .

*Remark VI.2:* One of the advantages of calculating the reinitialized state using the energy-based jump rule via (16) is its computational ease. This formula gives the reinitialized state in terms of the parameters of the system description of the LSS from (1) and the stored energy defined by the matrix  $K$ . The computation based on (16) requires two ingredients: the matrices  $P$  and  $K$ . The rows of the matrix  $P$  form a basis for the null-space of the matrix  $D_{\pi\pi}^T$ . As such, one can employ standard numerical linear algebra routines, for instance MATLAB's `null` command. Computation of  $K$  is quite straightforward by efficient LMI techniques (see, e.g., [33]), for instance, via the LMI Toolbox of MATLAB. Moreover, if the state variables are taken as voltages across capacitors and currents through inductors then the matrix  $K$  can be directly obtained from the capacitances and inductors as explained in detail in Remark VI.6. Once  $P$  and  $K$  are given, the explicit formula (16) requires only matrix inversion and multiplication.

#### B. Reinitialization via Laplace Transform Method

Another common method to resolve the jump issue is to use the Laplace transform. For a given switch configuration  $\pi$ , one can take the Laplace transform of (4). This yields

$$\hat{x}(s) = (sI - A)^{-1} [x_0 + B_{\pi\bullet}\hat{z}_\pi(s) + E\hat{u}(s)] \quad (18a)$$

$$\hat{z}_{\pi^c}(s) = 0 \quad (18b)$$

$$\begin{aligned} 0 &= \hat{w}_\pi(s) \\ &= C_{\pi\bullet}(sI - A)^{-1}x_0 + T_{\pi\pi}^z(s)\hat{z}_\pi(s) \\ &\quad + T_{\pi\bullet}^u(s)\hat{u}(s) \end{aligned} \quad (18c)$$

$$\begin{aligned} \hat{w}_{\pi^c}(s) &= C_{\pi^c\bullet}(sI - A)^{-1}x_0 + T_{\pi^c\pi}^z(s)\hat{z}_\pi(s) \\ &\quad + T_{\pi^c\bullet}^u(s)\hat{u}(s) \end{aligned} \quad (18d)$$

where  $\hat{\bullet}$  is the Laplace transform of the corresponding variable, whereas  $T^z(s) = D + C(sI - A)^{-1}B$  and  $T^u(s) = F + C(sI - A)^{-1}E$  are obtained from (1). For an initial state  $x_0$  and input  $u$ , one looks for a solution of (18). The following theorem provides conditions of solvability for these equations in case the underlying linear system is passive.

*Theorem VI.3:* Consider the LSS (1). Suppose that  $\Sigma(A, B, C, D)$  is passive with a positive definite storage function. Let  $x_0 \in \mathbb{R}^n$  be an initial state,  $\pi \subseteq \{1, 2, \dots, m\}$  be a switch configuration, and  $u$  be an admissible Bohl-type input with respect to the switch configuration  $\pi$ . Then, the following statements hold.

- 1) The equations in (18) admit a solution  $(\hat{x}(s), \hat{z}(s), \hat{w}(s))$  where the pair  $(\hat{z}(s), \hat{w}(s))$  is proper and  $\hat{x}(s)$  is strictly proper.
- 2) If  $(\hat{x}^i(s), \hat{z}^i(s), \hat{w}^i(s))$  with  $i = 1, 2$  are two solutions, then

$$\hat{x}^1(s) = \hat{x}^2(s) \quad (19a)$$

$$\hat{z}^1(s) - \hat{z}^2(s) \in \ker \begin{bmatrix} B \\ D + DT \end{bmatrix} \quad (19b)$$

$$\hat{w}^1(s) - \hat{w}^2(s) \in D \ker \begin{bmatrix} B \\ D + DT \end{bmatrix}. \quad (19c)$$

We define the unique value  $x_L^\dagger := \lim_{s \rightarrow \infty} s\hat{x}(s)$  as the *reinitialized state* for the Laplace transform method.

*Remark VI.4:* In order to compute the reinitialized state with Laplace transform method, one has to solve (18c) for  $\hat{z}_\pi(s)$ . This requires symbolic manipulation which increases computational burden heavily. In the literature, semisymbolic computation methods for solving (18c) have been introduced (see, e.g., [34]). These methods are based on interpolations on the unit circle and reduce the heavy computational burden of purely symbolic computations. Since the explicit formula (16) requires only matrix inversion and multiplication, the proposed method has a clear computational advantage over the Laplace transform method regardless of whether purely symbolic or semisymbolic techniques are employed. However, the explicit formula (16) is valid only for passive networks whereas the Laplace transform method is applicable to more general networks.

#### C. Equivalence of Energy-Based Jump Rule and Laplace Transform Based Jump Rule

So far, we have introduced a jump rule based on energy minimization and discussed the Laplace transform based jump rule. It turns out that the Laplace transform based and the energy-based jump rules are equivalent as stated in the following theorem.

*Theorem VI.5:* Consider the LSS (1). Suppose that  $\Sigma(A, B, C, D)$  is passive with a positive definite storage function. Let  $x_0 \in \mathbb{R}^n$  be an initial state,  $\pi \subseteq \{1, 2, \dots, m\}$  be a switch configuration, and  $u$  be an admissible Bohl-type input with respect to the switch configuration  $\pi$ . Then

$$x_E^\dagger = x_L^\dagger.$$

#### D. Charge/Flux Conservation Principle

Our next aim is to show that the energy-based jump rule and the principle of charge/flux conservation (for linear circuits containing resistors, capacitors, inductors, independent voltage/current sources, and ideal switches) yield the same reinitialized state.

In the general framework of LSS (1), the state variable  $x$  does not necessarily consist of capacitor voltages and inductor currents. As such, one cannot directly apply the charge/flux conservation principle to a general LSS.

First, we begin with deriving a particular LSS form of an electrical network (consisting of resistors, capacitors, inductors, independent voltage/current sources, and ideal switches) in such a way that the charge/flux conservation principle can be related to this LSS form.

*1) Derivation of Circuit Equations:* Consider a network whose elements are resistors, inductors, capacitors, independent sources, and switches. Suppose that the graph<sup>2</sup> associated to the network is connected and that capacitors do not form a loop (with or without voltage sources) and inductors do not form a cut set (with or without current sources). This assumption is

<sup>2</sup>We refer to [35] and [36] for the fundamental concepts of circuit theory.

not restrictive since if such a loop is present, one can break the loop by putting a switch in series to a capacitor (in the loop) and choose the switch configuration such that this extra switch is closed. A dual approach can be taken for inductors.

In order to obtain circuit equations, we first extract the ideal switches to the ports. For the remaining circuit, we consider a *proper tree*, i.e., a tree that contains all the voltage sources and the capacitors in the network, but no inductors and no current sources. It is always possible to find a proper tree (if no loops of capacitors/voltage sources and no cut sets of inductors/current sources are present). The capacitors are included in the tree branches, while the inductors in the links. The resistors, sources, and switches are included either in the branches or in the links in order to complete the tree. We partition the links and branches into eight subsets, namely the resistive links, the inductive links, the independent current source links, the port links, the capacitive branches, the resistive branches, the independent voltage source branches, and the port branches. Let  $\ell$  be the number of the links and  $b$  be the number of the branches. The Kirchhoff voltage law (KVL) applied to the  $\ell$  fundamental loops and the Kirchhoff current law (KCL) to the  $b$  fundamental cut sets are obtained as follows:

$$\begin{bmatrix} v_R \\ v_L \\ v_J \\ v_{P_\ell} \\ v_C \\ v_G \\ v_E \\ v_{P_b} \end{bmatrix} = 0, \quad [-H^T \quad I_b] \begin{bmatrix} i_R \\ i_L \\ i_J \\ i_{P_\ell} \\ i_C \\ i_G \\ i_E \\ i_{P_b} \end{bmatrix} = 0 \quad (20)$$

where  $v_R, v_L, v_J, v_{P_\ell}, v_C, v_G, v_E$ , and  $v_{P_b}$  are subvectors representing, respectively, voltages for the resistive links, the inductive links, the independent current source links, the port links, the capacitive branches, the resistive branches, the independent voltage source branches and the port branches;  $i_R, i_L, i_J, i_{P_\ell}, i_C, i_G, i_E$ , and  $i_{P_b}$  are subvectors representing, respectively, currents for the resistive links, the inductive links, the independent current source links, the port links, the capacitive branches, the resistive branches, the independent voltage source branches, and the port branches.

For the resistors, capacitors, and inductors, the constitutive laws of are given by

$$v_R = R_R i_R, i_G = G_G v_G, i_C = C \frac{d}{dt} v_C, v_L = L \frac{d}{dt} i_L \quad (21)$$

where  $R_R, L, C$ , and  $G_G$  are diagonal matrices with positive diagonal elements (or positive definite matrices to be more general) of appropriate sizes.

For the ideal switches, the constitutive laws are given by

$$\text{either } (v_{S_\ell})_i = 0 \text{ or } (i_{S_\ell})_i = 0 \quad (22a)$$

$$\text{either } (v_{S_b})_i = 0 \text{ or } (i_{S_b})_i = 0 \quad (22b)$$

where  $v_{S_\ell} = v_{P_\ell}, v_{S_b} = v_{P_b}, i_{S_\ell} = -i_{P_\ell}$ , and  $i_{S_b} = -i_{P_b}$ .

Let

$$H = \begin{bmatrix} H_{RC} & H_{RG} & H_{RE} & H_{RP_b} \\ H_{LC} & H_{LG} & H_{LE} & H_{LP_b} \\ H_{JC} & H_{JG} & H_{JE} & H_{JP_b} \\ H_{P_\ell C} & H_{P_\ell G} & H_{P_\ell E} & H_{P_\ell P_b} \end{bmatrix} \quad (23)$$

be a partition of the matrix  $H$  that conforms with the (20).

Using the KVL/KCL (20) and constitutive laws of the elements (21), one can obtain the following LSS form for the network:

$$\frac{d}{dt} \begin{bmatrix} v_C \\ i_L \end{bmatrix} = \mathcal{A} \begin{bmatrix} v_C \\ i_L \end{bmatrix} + \mathcal{B} \begin{bmatrix} v_{S_b} \\ i_{S_\ell} \end{bmatrix} + \mathcal{E} \begin{bmatrix} v_E \\ i_J \end{bmatrix} \quad (24a)$$

$$\begin{bmatrix} i_{S_b} \\ v_{S_\ell} \end{bmatrix} = \mathcal{C} \begin{bmatrix} v_C \\ i_L \end{bmatrix} + \mathcal{D} \begin{bmatrix} v_{S_b} \\ i_{S_\ell} \end{bmatrix} + \mathcal{F} \begin{bmatrix} v_E \\ i_J \end{bmatrix} \quad (24b)$$

$$\text{either } (i_{S_b})_i = 0 \text{ or } (v_{S_b})_i = 0 \quad (24c)$$

$$\text{either } (i_{S_\ell})_j = 0 \text{ or } (v_{S_\ell})_j = 0 \quad (24d)$$

for  $i = 1, \dots, m_{S_b}$  and  $j = 1, \dots, m_{S_\ell}$ , where  $m_{S_b}$  and  $m_{S_\ell}$  are the number of switches belonging to the port branches and to the port links, respectively. Here, the matrices are reported in (24e)–(24j), shown in the equation at the bottom of the page.

*Remark VI.6:* Naturally, the linear system  $\Sigma(\mathcal{A}, \mathcal{B}, \mathcal{C}, \mathcal{D})$  given by (24a) and (24b) forms a passive system with the storage function

$$V \left( \begin{bmatrix} v_C \\ i_L \end{bmatrix} \right) = \frac{1}{2} \begin{bmatrix} v_C \\ i_L \end{bmatrix}^T \underbrace{\begin{bmatrix} C & 0 \\ 0 & L \end{bmatrix}}_{\mathcal{K}} \begin{bmatrix} v_C \\ i_L \end{bmatrix}.$$

Indeed, this choice results in

$$\begin{bmatrix} \mathcal{A}^T \mathcal{K} + \mathcal{K} \mathcal{A} & \mathcal{K} \mathcal{B} - \mathcal{C}^T \\ \mathcal{B}^T \mathcal{K} - \mathcal{C} & -(\mathcal{D} + \mathcal{D}^T) \end{bmatrix} = \quad (25)$$

$$- \begin{bmatrix} H_{RC}^T & 0 \\ 0 & H_{LG} \\ H_{RP_b}^T & 0 \\ 0 & -H_{P_\ell G} \end{bmatrix} \begin{bmatrix} \mathcal{R}^{-1} & 0 \\ 0 & \mathcal{G}^{-1} \end{bmatrix} \\ \times \begin{bmatrix} H_{RC}^T & 0 \\ 0 & H_{LG} \\ H_{RP_b}^T & 0 \\ 0 & -H_{P_\ell G} \end{bmatrix}^T \leq 0. \quad (26)$$

Note that  $\mathcal{K}$  is clearly positive definite.

*Example VI.7:* Consider the circuit depicted in Fig. 1. By taking a tree consisting of the voltage source  $v_E$ , the switch  $S_2$ , and the capacitor  $C$ ; and applying KVL, one arrives at the equations

$$\begin{bmatrix} 1 & 0 & 0 & -1 & 0 & 0 \\ 0 & 1 & 0 & -1 & 0 & 1 \\ 0 & 0 & 1 & 0 & -1 & 1 \end{bmatrix} \begin{bmatrix} v_R \\ v_L \\ v_{P_1} \\ v_C \\ v_E \\ v_{P_2} \end{bmatrix} = 0.$$

This results in

$$\frac{d}{dt} \begin{bmatrix} v_C \\ i_L \end{bmatrix} = \mathcal{A} \begin{bmatrix} v_C \\ i_L \end{bmatrix} + \mathcal{B} \begin{bmatrix} v_{S_2} \\ i_{S_1} \end{bmatrix} + \mathcal{E} v_E \\ \begin{bmatrix} i_{S_2} \\ v_{S_1} \end{bmatrix} = \mathcal{C} \begin{bmatrix} v_C \\ i_L \end{bmatrix} + \mathcal{D} \begin{bmatrix} v_{S_2} \\ i_{S_1} \end{bmatrix} + \mathcal{F} v_E$$

where

$$\mathcal{A} = \begin{bmatrix} C & 0 \\ 0 & L \end{bmatrix}^{-1} \begin{bmatrix} -\frac{1}{R} & -1 \\ 1 & 0 \end{bmatrix} = \begin{bmatrix} -\frac{1}{RC} & -\frac{1}{C} \\ \frac{1}{L} & 0 \end{bmatrix}, \\ \mathcal{B} = \begin{bmatrix} C & 0 \\ 0 & L \end{bmatrix}^{-1} \begin{bmatrix} 0 & 0 \\ -1 & 0 \end{bmatrix} = \begin{bmatrix} 0 & 0 \\ -\frac{1}{L} & 0 \end{bmatrix}, \\ \mathcal{C} = \begin{bmatrix} 0 & -1 \\ 0 & 0 \end{bmatrix}, \quad \mathcal{D} = \begin{bmatrix} 0 & 1 \\ -1 & 0 \end{bmatrix}, \\ \mathcal{E} = \begin{bmatrix} 0 \\ 0 \end{bmatrix} = \begin{bmatrix} 0 \\ 0 \end{bmatrix}, \quad \mathcal{F} = \begin{bmatrix} 0 \\ 1 \end{bmatrix}.$$

Next, we formalize the charge/flux conservation principle with the help of the special LSS form obtained above.

2) *Formulation of Charge/Flux Conservation Principle:* The principle of charge/flux conservation is applied to a network in order to obtain consistent initial conditions for the state variables (capacitance voltages and inductance currents). The principle of

$$\mathcal{A} = \begin{bmatrix} C & 0 \\ 0 & L \end{bmatrix}^{-1} \begin{bmatrix} -H_{RC}^T \mathcal{R}^{-1} H_{RC} & H_{LC}^T - H_{RC}^T \mathcal{Z} H_{LG}^T \\ -H_{LC} + H_{LG} \mathcal{Z}^T H_{RC} & -H_{LG} \mathcal{G}^{-1} H_{LG}^T \end{bmatrix} \quad (24e)$$

$$\mathcal{B} = \begin{bmatrix} C & 0 \\ 0 & L \end{bmatrix}^{-1} \begin{bmatrix} -H_{RC}^T \mathcal{R}^{-1} H_{RP_b} & -H_{P_\ell C}^T + H_{RC}^T \mathcal{Z} H_{P_\ell G}^T \\ -H_{LP_b} + H_{LG} \mathcal{Z}^T H_{RP_b} & H_{LG} \mathcal{G}^{-1} H_{P_\ell G}^T \end{bmatrix} \quad (24f)$$

$$\mathcal{C} = \begin{bmatrix} H_{RP_b}^T \mathcal{R}^{-1} H_{RC} & -H_{LP_b}^T + H_{RP_b}^T \mathcal{Z} H_{LG}^T \\ -H_{P_\ell C} + H_{P_\ell G} \mathcal{Z}^T H_{RC} & -H_{P_\ell G} \mathcal{G}^{-1} H_{LG}^T \end{bmatrix} \quad (24g)$$

$$\mathcal{D} = \begin{bmatrix} H_{RP_b}^T \mathcal{R}^{-1} H_{RP_b} & H_{P_\ell P_b}^T - H_{RP_b}^T \mathcal{Z} H_{P_\ell G}^T \\ -H_{P_\ell P_b} + H_{P_\ell G} \mathcal{Z}^T H_{RP_b} & H_{P_\ell G} \mathcal{G}^{-1} H_{P_\ell G}^T \end{bmatrix} \quad (24h)$$

$$\mathcal{E} = \begin{bmatrix} C & 0 \\ 0 & L \end{bmatrix}^{-1} \begin{bmatrix} -H_{RC}^T \mathcal{R}^{-1} H_{RE} & H_{JC}^T - H_{RC}^T \mathcal{Z} H_{JG}^T \\ -H_{LE} + H_{LG} \mathcal{Z}^T H_{RE} & -H_{LG} \mathcal{G}^{-1} H_{JG}^T \end{bmatrix} \quad (24i)$$

$$\mathcal{F} = \begin{bmatrix} H_{RP_b}^T \mathcal{R}^{-1} H_{RE} & -H_{JP_b}^T + H_{RP_b}^T \mathcal{Z} H_{JG}^T \\ -H_{P_\ell E} + H_{P_\ell G} \mathcal{Z}^T H_{RE} & -H_{P_\ell G} \mathcal{G}^{-1} H_{JG}^T \end{bmatrix} \quad (24j)$$

$$R_G = G_G^{-1}, \quad G_R = R_R^{-1}, \quad \mathcal{R} = R_R + H_{RG} R_G H_{RG}^T, \quad (24k)$$

$$\mathcal{G} = G_G + H_{RG}^T G_R H_{RG} \quad (24k)$$

$$\mathcal{Z} = G_R H_{RG} \mathcal{G}^{-1} = \mathcal{R}^{-1} H_{RG} R_G. \quad (24l)$$



TABLE I  
TRANSFERRED CHARGE/FLUX RELATIONS FOR CIRCUIT ELEMENTS

transferred	capacitor	inductor	resistor	voltage source	current source	ports
charge	$q_C = C(v_C^+ - v_C^-)$	0	0	$q_E$	0	$q_P$
flux	0	$\phi_L = L(i_L^+ - i_L^-)$	0	0	$\phi_J$	$\phi_P$

charge conservation states that the total charge transferred into a junction or out of a junction at any time is zero. Dually, the principle of flux conservation states that the flux summed over any closed loop is continuous. As such, KCL is valid in terms of the transferred charges for a node and KVL is valid in terms of the transferred fluxes for a loop with the definitions of transferred charges/fluxes for different elements shown in Table I. In this table,  $\bullet^-$  denotes the corresponding value before discontinuity and  $\bullet^+$  after discontinuity.

For the principle of charge conservation, these definitions, together with (20), yield

$$v_C^+ = v_C^- + C^{-1}q_C \quad (27a)$$

and

$$\begin{bmatrix} q_C \\ 0 \\ q_E \\ q_{P_b} \end{bmatrix} = H^T \begin{bmatrix} 0 \\ 0 \\ 0 \\ q_{P_\ell} \end{bmatrix} \quad (27b)$$

where  $q_C$ ,  $q_E$ ,  $q_{P_b}$ , and  $q_{P_\ell}$ , respectively, correspond to the charges transferred to the capacitors, voltage sources, port branches, and port links.

From (20), the KVL after the discontinuity is given by

$$\begin{bmatrix} v_R^+ \\ v_L^+ \\ v_J^+ \\ v_{P_\ell}^+ \end{bmatrix} = -H \begin{bmatrix} v_C^+ \\ v_G^+ \\ v_E^+ \\ v_{P_b}^+ \end{bmatrix}. \quad (27c)$$

Analogously, it is possible to derive a set of equations for the principle of flux conservation

$$i_L^+ = i_L^- + L^{-1}\phi_L. \quad (27d)$$

and

$$\begin{bmatrix} 0 \\ \phi_L \\ \phi_J \\ \phi_{P_\ell} \end{bmatrix} = -H \begin{bmatrix} 0 \\ 0 \\ 0 \\ \phi_{P_b} \end{bmatrix} \quad (27e)$$

where  $\phi_L$ ,  $\phi_J$ ,  $\phi_{P_b}$ , and  $\phi_{P_\ell}$ , respectively, correspond to the fluxes transferred to the inductors, current sources, port branches, and port links.

From (20), the KCL after the discontinuity is given by

$$\begin{bmatrix} i_C^+ \\ i_G^+ \\ i_E^+ \\ i_{P_b}^+ \end{bmatrix} = H^T \begin{bmatrix} i_R^+ \\ i_L^+ \\ i_J^+ \\ i_{P_\ell}^+ \end{bmatrix}. \quad (27f)$$

Finally, the constitutive laws of the switches have to be considered

$$\begin{aligned} &\text{either} \quad \left[ (i_{S_b}^+)_i = 0 \text{ and } (q_{P_b})_i = 0 \right] \\ &\text{or} \quad \left[ (v_{S_b}^+)_i = 0 \text{ and } (\phi_{P_b})_i = 0 \right] \end{aligned} \quad (27g)$$

$$\begin{aligned} &\text{either} \quad \left[ (i_{S_\ell}^+)_i = 0 \text{ and } (q_{P_\ell})_i = 0 \right] \\ &\text{or} \quad \left[ (v_{S_\ell}^+)_i = 0 \text{ and } (\phi_{P_\ell})_i = 0 \right] \end{aligned} \quad (27h)$$

where  $v_{S_\ell}^+ = v_{P_\ell}^+$ ,  $v_{S_b}^+ = v_{P_b}^+$ ,  $i_{S_\ell}^+ = -i_{P_\ell}^+$ , and  $i_{S_b}^+ = -i_{P_b}^+$ .

*Remark VI.8:* The existing methods based on the charge/flux conservation principle (see, e.g., [8], [10], [19]) require the circuit equations for the *given* switch configuration as input. When one wants to analyze *another* switch configuration, the corresponding governing equations should be derived for the new configuration. The LSS framework makes it possible to apply the charge/flux conservation principle to *any* switch configuration without deriving the circuit equations for each topology. To our knowledge, the formalization of the charge/flux conservation principle for an arbitrary switch configuration had not been studied in the literature before.

With all above preparations, we are ready to show the equivalence of the charge/flux conservation principle to the energy-based jump rule in what follows.

#### E. Equivalence of Charge/Flux Conservation Principle and Energy-Based Jump Rule

Principle of charge/flux conservation says that  $v_C^+$  and  $i_L^+$ , satisfying the relations in (27) for a given switch configuration,  $v_C^-$ ,  $i_L^-$ ,  $v_E^+$ , and  $i_J^+$ , should be taken as the reinitialized state for the network. Naturally, one should ask if there exists a solution  $v_C^+$  and  $i_L^+$  that satisfy those relations. If such a solution exists, the next natural question is to ask whether it is unique. To our knowledge, these questions have not been formally answered in the literature.

In what follows, we will show that any solution  $v_C^+$  and  $i_L^+$  for the relations in (27) coincides with the one obtained from energy-based jump rule. Hence, this solution is the unique solution.

*Theorem VI.9:* Consider the LSS  $(\mathcal{A}, \mathcal{B}, \mathcal{C}, \mathcal{D}, \mathcal{E}, \mathcal{F})$ . For any given switch configuration,  $v_C^-$ ,  $i_L^-$ ,  $v_E^+$ , and  $i_J^+$ , the reinitialized state  $\text{col}(v_C^+, i_L^+)$  obtained by charge/flux conservation principle (27) coincides with the reinitialized state obtained by energy-based jump rule. As such charge/flux conservation principle (27) always yields a unique solution.

*Remark VI.10:* Together with the general formulation of charge/flux conservation principle based on the LSS framework, above theorem indicates that the energy-based jump rule has no computational advantage over that of charge/flux conservation principle. However, the existing methods (see, e.g., [8], [10], [19]) based on charge/flux conservation principle require the derivation of corresponding circuit equations for the given configuration. Thanks to the LSS framework, the energy-based jump rule is given as an explicit formula which works for *any* switch topology without deriving governing equations of each topology separately. In this sense, the energy-based jump rule has considerable computational advantage over the existing methods based on charge/flux conservation principle.

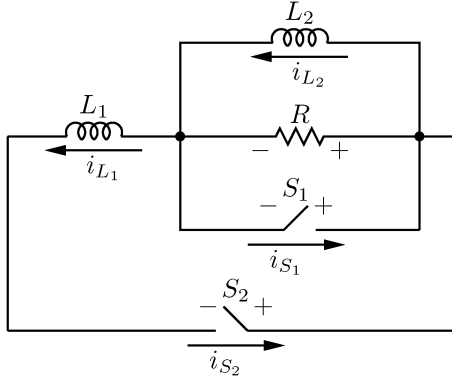

Fig. 3. Switched network of Example VII.3.

## VII. EXAMPLES

In this section, we illustrate the computational simplicity of the new method on some examples considered in the literature within the context of switched electrical networks. The first one is the ubiquitous two-capacitor example.

*Example VII.1:* Consider the circuit depicted in Fig. 2. An LSS form for this circuit was given in (6). Suppose that the switch configuration is given by  $\pi = \{1\}$ , i.e., the switch is closed. Since  $D = 0$ , one can take  $P = 1$  in Theorem VI.1. Note that  $K$  can be taken as a diagonal matrix with the diagonal elements  $C_1$  and  $C_2$ . Then, it follows from Theorem VI.1 that

$$\begin{aligned} \begin{bmatrix} v_{C_1}(0^+) \\ v_{C_2}(0^+) \end{bmatrix} &= \begin{bmatrix} v_{C_1}(0^-) \\ v_{C_2}(0^-) \end{bmatrix} - (C_1^{-1} + C_2^{-1})^{-1} \begin{bmatrix} -C_1^{-1} \\ C_2^{-1} \end{bmatrix} \\ &\quad \times (-v_{C_1}(0^-) + v_{C_2}(0^-)) \\ &= \begin{bmatrix} C_1 v_{C_1}(0^-) + C_2 v_{C_2}(0^-) \\ C_2 + C_1 \\ C_1 v_{C_1}(0^-) + C_2 v_{C_2}(0^-) \\ C_2 + C_1 \end{bmatrix}. \end{aligned} \quad (28)$$

*Example VII.2:* Consider the circuit depicted in Fig. 1. An LSS form for this circuit was given in (3). Take  $\pi = \{2\}$ . Since  $D_{22} = 0$ , one can take  $P = 1$  in Theorem VI.1. Note that  $K$  can be taken as a diagonal matrix with the diagonal elements  $C$  and  $L$ . Then, it follows from Theorem VI.1 that

$$\begin{bmatrix} v_C(0^+) \\ i_L(0^+) \end{bmatrix} = \begin{bmatrix} v_C(0^-) \\ i_L(0^-) \end{bmatrix} - L \begin{bmatrix} 0 \\ L^{-1} \end{bmatrix} i_L(0^-) = \begin{bmatrix} v_C(0^-) \\ 0 \end{bmatrix}.$$

*Example VII.3:* Consider the circuit depicted in Fig. 3 that was investigated in [10]. It can be expressed in the LSS form as follows:

$$\begin{aligned} \frac{d}{dt} \begin{bmatrix} i_{L_1} \\ i_{L_2} \end{bmatrix} &= \begin{bmatrix} -\frac{R}{L_1} & \frac{R}{L_1} \\ \frac{R}{L_2} & -\frac{R}{L_2} \end{bmatrix} \begin{bmatrix} i_{L_1} \\ i_{L_2} \end{bmatrix} + \begin{bmatrix} -\frac{R}{L_1} & \frac{1}{L_1} \\ \frac{R}{L_2} & 0 \end{bmatrix} \begin{bmatrix} i_{S_1} \\ v_{S_2} \end{bmatrix} \\ \begin{bmatrix} v_{S_1} \\ i_{S_2} \end{bmatrix} &= \begin{bmatrix} R & -R \\ 1 & 0 \end{bmatrix} \begin{bmatrix} i_{L_1} \\ i_{L_2} \end{bmatrix} + \begin{bmatrix} R & 0 \\ 0 & 0 \end{bmatrix} \begin{bmatrix} i_{S_1} \\ v_{S_2} \end{bmatrix}. \end{aligned}$$

Take  $\pi = \{2\}$ . Since  $D_{22} = 0$ , one can take  $P = 1$  in Theorem VI.1. Note that  $K$  can be taken as a diagonal matrix with the diagonal elements  $L_1$  and  $L_2$ . Then, it follows from Theorem VI.1 that

$$\begin{bmatrix} i_{L_1}(0^+) \\ i_{L_2}(0^+) \end{bmatrix} = \begin{bmatrix} i_{L_1}(0^-) \\ i_{L_2}(0^-) \end{bmatrix} - \begin{bmatrix} L_1^{-1} \\ 0 \end{bmatrix} L_1 i_{L_1}(0^-) = \begin{bmatrix} 0 \\ i_{L_2}(0^-) \end{bmatrix}.$$

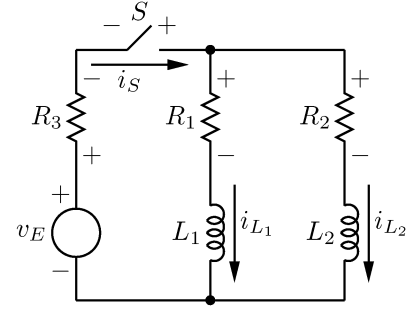

Fig. 4. Switched network of Example VII.4.

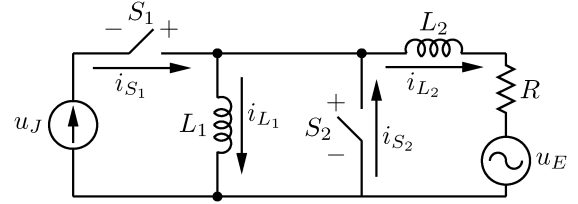

Fig. 5. Switched network of Example VII.5.

*Example VII.4:* Consider the circuit depicted in Fig. 4 that was investigated in [11]. It can be expressed in the LSS form as follows:

$$\begin{aligned} \frac{d}{dt} \begin{bmatrix} i_{L_1} \\ i_{L_2} \end{bmatrix} &= \begin{bmatrix} -\frac{R_1}{L_1} - \frac{R_3}{L_1} & -\frac{R_3}{L_1} \\ -\frac{R_3}{L_2} & -\frac{R_2}{L_2} - \frac{R_3}{L_2} \end{bmatrix} \begin{bmatrix} i_{L_1} \\ i_{L_2} \end{bmatrix} \\ &\quad + \begin{bmatrix} \frac{1}{L_1} \\ \frac{1}{L_2} \end{bmatrix} v_S + \begin{bmatrix} \frac{1}{L_1} \\ \frac{1}{L_2} \end{bmatrix} v_E \\ i_S &= [1 \quad 1] \begin{bmatrix} i_{L_1} \\ i_{L_2} \end{bmatrix} \end{aligned}$$

Take  $\pi = \{1\}$ . Since  $D = 0$ , one can take  $P = 1$ . Note that  $K$  can be taken as a diagonal matrix with the diagonal elements  $L_1$  and  $L_2$ . Then, we get

$$\begin{aligned} \begin{bmatrix} i_{L_1}(0^+) \\ i_{L_2}(0^+) \end{bmatrix} &= \begin{bmatrix} i_{L_1}(0^-) \\ i_{L_2}(0^-) \end{bmatrix} - \begin{bmatrix} L_1^{-1} \\ L_2^{-1} \end{bmatrix} (L_1^{-1} + L_2^{-1})^{-1} \\ &\quad \times (i_{L_1}(0^-) + i_{L_2}(0^-)) \\ &= \begin{bmatrix} L_1 i_{L_1}(0^-) - L_2 i_{L_2}(0^-) \\ L_1 + L_2 \\ L_2 i_{L_2}(0^-) - L_1 i_{L_1}(0^-) \\ L_1 + L_2 \end{bmatrix}. \end{aligned}$$

*Example VII.5:* Consider the circuit depicted in Fig. 5 that was investigated in [1, Sec. IV-C]. It can be expressed in the LSS form as follows:

$$\begin{aligned} \frac{d}{dt} \begin{bmatrix} i_{L_1} \\ i_{L_2} \end{bmatrix} &= \begin{bmatrix} 0 & 0 \\ 0 & -\frac{R}{L_2} \end{bmatrix} \begin{bmatrix} i_{L_1} \\ i_{L_2} \end{bmatrix} + \begin{bmatrix} 0 & \frac{1}{L_1} \\ 0 & \frac{1}{L_2} \end{bmatrix} \begin{bmatrix} v_{S_1} \\ v_{S_2} \end{bmatrix} \\ &\quad + \begin{bmatrix} 0 & 0 \\ -\frac{1}{L_2} & 0 \end{bmatrix} \begin{bmatrix} u_E \\ u_J \end{bmatrix} \\ \begin{bmatrix} i_{S_1} \\ i_{S_2} \end{bmatrix} &= \begin{bmatrix} 0 & 0 \\ 1 & 1 \end{bmatrix} \begin{bmatrix} i_{L_1} \\ i_{L_2} \end{bmatrix} + \begin{bmatrix} 0 & -1 \\ 0 & -1 \end{bmatrix} \begin{bmatrix} u_E \\ u_J \end{bmatrix}. \end{aligned}$$

Take  $\pi = \{2\}$ . Since  $D = 0$ , one can take  $P = 1$  in Theorem VI.1. Note that  $K$  can be taken as a diagonal matrix with the diagonal elements  $L_1$  and  $L_2$ . Then, it follows from Theorem

VI.1 that

$$\begin{aligned} \begin{bmatrix} i_{L_1}(0^+) \\ i_{L_2}(0^+) \end{bmatrix} &= \begin{bmatrix} i_{L_1}(0^-) \\ i_{L_2}(0^-) \end{bmatrix} - \begin{bmatrix} L_1^{-1} \\ L_2^{-1} \end{bmatrix} (L_1^{-1} + L_2^{-1})^{-1} \\ &\quad \times (i_{L_1}(0^-) + i_{L_2}(0^-) - u_J(0)) \\ &= \begin{bmatrix} \frac{L_1 i_{L_1}(0^-) - L_2 i_{L_2}(0^-) + L_2 u_J(0)}{L_1 + L_2} \\ \frac{L_2 i_{L_2}(0^-) - L_1 i_{L_1}(0^-) + L_1 u_J(0)}{L_1 + L_2} \end{bmatrix}. \end{aligned}$$

### VIII. CONCLUSIONS

A single compact framework called linear switched systems was employed for linear networks with ideal switches; this framework, which is valid for any switch configuration unifies and simplifies the analysis of such circuits. Within this framework, a complete characterization of admissible inputs and consistent states was presented. Under the passivity assumption for general systems, a new state reinitialization method based on energy minimization was developed. The advantages of the method, besides providing a clear insight to state discontinuities, are threefold.

- It is independent of any network topology and nature (applicable to any linear switch system).
- It is computationally simpler over the existing methods which need to reanalyze the circuit each time a new switch configuration is adopted.
- More importantly, it provides once more a proof that nature settles itself by consuming the minimum amount of energy.

This new method was shown to yield the same reinitialized state as:

- the one provided by using the Laplace transform techniques applied to linear switch systems (without any distribution theory or any Dirac delta functional);
- the charge/flux conservation principle based state reinitialization rules (by providing a rigorous derivation for electrical circuits).

Two main directions arise as possibilities for further research. Extensions of the presented results for networks containing other types of switching elements such as ideal diodes and thyristors forms one of these directions; the other direction is to investigate the energy-based reinitialization rule for active and/or nonlinear circuits.

### APPENDIX PROOFS

For the proofs, we need two auxiliary results. The first one is concerned with the consequences of passivity.

*Lemma A.1 [32, Lemma 2.5]:* Suppose that the system  $\Sigma(A, B, C, D)$  is passive. Let  $K$  be any solution to LMIs (10) and let  $G(s) = D + C(sI - A)^{-1}B$ . Then, the following statements hold.

- $D$  is positive semidefinite.
- $\bar{u}^T(D + D^T)\bar{u} = 0 \Rightarrow C^T\bar{u} = K B \bar{u}$ .
- $\ker \begin{bmatrix} C^T \\ D + D^T \end{bmatrix} = \ker \begin{bmatrix} K B \\ D + D^T \end{bmatrix}$ .
- $\bar{u} \in \ker K B \Rightarrow G(s)\bar{u} = D\bar{u}$  for all complex numbers  $s$ .
- $\ker[G(\sigma) + G^T(\sigma)] = \ker \begin{bmatrix} K B \\ D + D^T \end{bmatrix}$  for all real positive numbers  $\sigma$  that are not eigenvalues of  $A$ .

The second auxiliary result provides conditions for the solvability of rational equations under a passivity assumption.

*Theorem A.2:* Consider the rational equation

$$0 = C(sI - A)^{-1}x_0 + [\mathcal{F} + C(sI - A)^{-1}\mathcal{E}] \hat{u}(s) + [D + C(sI - A)^{-1}\mathcal{B}] \hat{z}(s) \quad (29)$$

where the matrices  $\mathcal{A}, \mathcal{B}, \mathcal{C}, \mathcal{D}, \mathcal{E}, \mathcal{F}$  are of appropriate sizes,  $\hat{u}$  is a strictly proper rational, and  $\hat{z}$  a rational function. Suppose that the linear system  $\Sigma(\mathcal{A}, \mathcal{B}, \mathcal{C}, \mathcal{D})$  is passive with a positive definite storage function. Then, the following statements hold.

- The following statements are equivalent.
  - The relation  $\mathcal{F}u(t) \in \text{im}[C \ D]$  is satisfied for all  $t \geq 0$ .
  - Equation (29) admits a solution  $\hat{z}$  for a given  $x_0$  and  $\hat{u}$ .
  - Equation (29) admits a proper solution  $\hat{z}$  for a given  $x_0$  and  $\hat{u}$ .

Moreover, if  $\hat{z}_1$  and  $\hat{z}_2$  are two solutions to (29), then  $\text{col}(\mathcal{B}, \mathcal{D} + \mathcal{D}^T)(\hat{z}_1(s) - \hat{z}_2(s)) = 0$ .

- The following statements are equivalent.
  - The relation  $\mathcal{F}u(t) \in \text{im}[C \ D]$  is satisfied for all  $t \geq 0$  and  $Cx_0 + \mathcal{F}u(0) \in \text{im}D$ .
  - Equation (29) admits a strictly proper solution  $\hat{z}$  for a given  $x_0$  and  $\hat{u}$ .

*Proof:* *1a*  $\Rightarrow$  *1b*: Let  $\mathcal{G}(s) = D + C(sI - A)^{-1}\mathcal{B}$  and  $\hat{q}(s) = C(sI - A)^{-1}x_0 + [\mathcal{F} + C(sI - A)^{-1}\mathcal{E}]\hat{u}(s)$ . It follows from [37, Th. 4.1] that (29) admits a solution if and only if

$$0 = \hat{q}(\sigma) + \mathcal{G}(\sigma)\hat{z}(\sigma) \quad (30)$$

admits a solution for all sufficiently large real numbers  $\sigma$ . Since  $\mathcal{F}u(t) \in \text{im}[C \ D]$  for all  $t \geq 0$ ,  $\hat{q}(\sigma) \in \text{im}[C \ D]$  for all real numbers  $\sigma$ . Therefore, it would suffice to prove that

$$\text{im } \mathcal{G}(\sigma) \subseteq \text{im}[C \ D] \quad (31)$$

for all sufficiently large real numbers  $\sigma$ . To see this, let  $\sigma$  be a positive real number greater than all real eigenvalues of  $\mathcal{A}$ . Also let  $\bar{u} \in \ker \mathcal{G}(\sigma)$ . Due to passivity,  $\mathcal{G}(\sigma)$  is positive semidefinite. This means that  $\bar{u} \in \ker(\mathcal{G}(\sigma) + \mathcal{G}^T(\sigma))$ . By using Lemma A.1 v) and iv), we get  $\mathcal{G}(\sigma)\bar{u} = D\bar{u}$ . This means  $\bar{u} \in \ker D$ . From Lemma A.1 v) and iii), we already have  $\bar{u} \in \ker C^T$ . Then, we get

$$\ker \mathcal{G}(\sigma) \subseteq \ker C^T \cap \ker D. \quad (32)$$

To see the reverse inclusion, let  $\bar{u} \in \ker C^T \cap \ker D$ . Thus,  $C^T\bar{u} = 0$  and  $D\bar{u} = 0$ . From Lemma A.1 i), we know that  $D$  is positive semidefinite. This allows us to say that  $\bar{u} \in \ker(D + D^T) \cap \ker C^T$ . By invoking Lemma A.1 iii), iv), and v), we get  $D\bar{u} = \mathcal{G}(\sigma)\bar{u}$ . This means that  $\bar{u} \in \ker \mathcal{G}(\sigma)$ . Therefore,

$$\ker \mathcal{G}(\sigma) \supseteq \ker C^T \cap \ker D. \quad (33)$$

Then, (31) follows from (32) and (33).

*1b*  $\Rightarrow$  *1c*: Let  $\hat{z}$  be a solution to (29). Suppose that  $\hat{z}(s) = \hat{z}_p s^p + \hat{z}_{p-1} s^{p-1} + \hat{z}'(s)$  where  $\lim_{s \rightarrow \infty} s^{-p+1} \hat{z}'(s) = 0$ . If  $p \leq 0$  then  $\hat{z}$  is proper. Suppose that  $p \geq 1$ . Note that (29) implies that

$$D\hat{z}_p = 0 \quad (34)$$

$$D\hat{z}_{p-1} + C\mathcal{B}\hat{z}_p = 0 \quad (35)$$

since these are the coefficients of  $s^p$  and  $s^{p-1}$  of the right hand side. By left-multiplying the latter by  $\hat{z}_p^T$  and using Lemma A.1 ii) and iv), one gets

$$\mathcal{G}(s)\hat{z}_p = 0. \quad (36)$$

This means that  $\hat{z}_{p-1}s^{p-1} + \hat{z}'(s)$  is also a solution of (29). Clearly, one can find a proper solution by employing the above argument repeatedly.

*1c*  $\Rightarrow$  *1a*: Let  $\hat{z}(s)$  be a proper solution to (29). Note that  $\mathcal{F}\hat{u}$  lies in  $\text{im}[\mathcal{C} \ \mathcal{D}]$ .

*the rest of 1*: It follows from (29) that

$$\mathcal{G}(s)(\hat{z}_1(s) - \hat{z}_2(s)) = 0. \quad (37)$$

From Proposition IV.3.4 and Lemma A.1.i), we get that

$$\hat{z}_1(\sigma) - \hat{z}_2(\sigma) \in \ker \begin{bmatrix} \mathcal{B} \\ \mathcal{D} + \mathcal{D}^T \end{bmatrix} \quad (38)$$

for all sufficiently large positive real numbers  $\sigma$ . Since  $\hat{z}_i(s)$  is rational, we can further conclude that

$$\hat{z}_1(s) - \hat{z}_2(s) \in \ker \begin{bmatrix} \mathcal{B} \\ \mathcal{D} + \mathcal{D}^T \end{bmatrix}. \quad (39)$$

*2a*  $\Rightarrow$  *2b*: From the first part of the theorem, we know that (29) admits a proper solution, say  $\hat{z}$ . Let  $\hat{z}(s) = \hat{z}_0 + \hat{z}_{-1}s^{-1} + \hat{z}'(s)$  where  $\lim_{s \rightarrow \infty} s\hat{z}'(s) = 0$ . From (29), we get

$$\mathcal{D}\hat{z}_0 = 0 \quad (40)$$

$$\mathcal{C}x_0 + \mathcal{F}u(0) + \mathcal{D}\hat{z}_{-1} + \mathcal{C}\mathcal{B}\hat{z}_0 = 0. \quad (41)$$

By left-multiplying the latter by  $\hat{z}_0^T$ , using Lemma A.1 ii) and iv), and the fact that  $\mathcal{C}x_0 + \mathcal{F}u(0) \in \text{im}\mathcal{D}$ , one gets

$$\mathcal{G}(s)\hat{z}_0 = 0. \quad (42)$$

Consequently,  $\hat{z}_{-1}s^{-1} + \hat{z}'(s)$  is a strictly proper solution to (29).

*2b*  $\Rightarrow$  *2a*: The relation  $\mathcal{F}u(t) \in \text{im}[\mathcal{C} \ \mathcal{D}]$  readily follows from the first part of the theorem. Let  $\hat{z}$  be a strictly proper solution with  $\hat{z}(s) = \hat{z}_{-1}s^{-1} + \hat{z}'(s)$  where  $\lim_{s \rightarrow \infty} s\hat{z}'(s) = 0$ . It follows from (29) that

$$\mathcal{C}x_0 + \mathcal{F}u(0) + \mathcal{D}\hat{z}_{-1} = 0. \quad (43)$$

Hence,  $\mathcal{C}x_0 + \mathcal{F}u(0) \in \text{im}\mathcal{D}$ . ■

#### A. Proof of Theorem V.1

1) Necessity readily follows from (4c). For sufficiency, let  $x_0$  be such that  $\mathcal{C}_{\pi\bullet}x_0 + \mathcal{F}_{\pi\bullet}u(0) \in \text{im}D_{\pi\pi}$ . Take  $\mathcal{A} = A$ ,  $\mathcal{B} = B_{\pi\bullet}$ ,  $\mathcal{C} = C_{\pi\bullet}$ ,  $\mathcal{D} = D_{\pi\pi}$ ,  $\mathcal{E} = E$ , and  $\mathcal{F} = F_{\pi\bullet}$ . Since  $\Sigma(\mathcal{A}, \mathcal{B}, \mathcal{C}, \mathcal{D})$  is passive with some positive storage function, so is  $\Sigma(\mathcal{A}, \mathcal{B}, \mathcal{C}, \mathcal{D})$  with the same storage function. By applying Theorem A.2, we get the desired solution for the initial state  $x_0$  and the input  $u$ .

2) Similar to the previous case, necessity immediately follows from (4c) and sufficiency can be proven by applying the very same argument. ■

#### B. Proof of Theorem VI.1

1) Let  $P$  be a matrix of appropriate dimensions such that  $\ker P = \text{im}D_{\pi\pi}$ . Then, the constrained minimization problem (15) can be rewritten as

$$\begin{aligned} & \text{minimize } \frac{1}{2}(x^+ - x_0)^T K(x^+ - x_0) \\ & \text{subject to } P(\mathcal{C}_{\pi\bullet}x^+ + \mathcal{F}_{\pi\bullet}u(0)) = 0. \end{aligned}$$

Let  $L$  be the Lagrangian associated to this problem, i.e.,

$$L = \frac{1}{2}(x^+ - x_0)^T K(x^+ - x_0) + \lambda^T P(\mathcal{C}_{\pi\bullet}x^+ + \mathcal{F}_{\pi\bullet}u(0)).$$

By differentiating  $L$  with respect to the unknown  $x^+$  and the Lagrange multiplier  $\lambda$  and equating these derivatives to zero, one gets

$$0 = K(x^+ - x_0) + \mathcal{C}_{\pi\bullet}^T P^T \lambda \quad (44a)$$

$$0 = P(\mathcal{C}_{\pi\bullet}x^+ + \mathcal{F}_{\pi\bullet}u(0)). \quad (44b)$$

These conditions are known as Karush–Kuhn–Tucker conditions (see, e.g., [38]) and they are known to be necessary conditions for optimality. When the cost function is convex and the constraint set closed, they are also known to be sufficient conditions for optimality (see, e.g., [38]). Note that the cost function of (15) is (even strictly) convex as  $K$  is positive definite and the constraint set is closed as it is given by linear equations. Hence, we can conclude that the above Karush–Kuhn–Tucker conditions are necessary and sufficient for  $x^+$  being a solution of (15). By solving  $x^+$  from the first condition, one obtains

$$PC_{\pi\bullet}K^{-1}\mathcal{C}_{\pi\bullet}^T P^T \lambda = PC_{\pi\bullet}x_0 + PF_{\pi\bullet}u(0). \quad (45)$$

It follows from elementary linear algebra that  $\text{im}PC_{\pi\bullet}K^{-1}\mathcal{C}_{\pi\bullet}^T P^T = \text{im}PC_{\pi\bullet}$ . This means that this linear equation has a solution if and only if  $PF_{\pi\bullet}u(0) \in \text{im}PC_{\pi\bullet}$ . To see that this condition holds, note that

$$F_{\pi\bullet}u(0) \in \text{im}[\mathcal{C}_{\pi\bullet} \ D_{\pi\pi}]$$

since  $u$  is admissible. As  $PD_{\pi\pi} = 0$  by definition, one gets

$$PF_{\pi\bullet}u(0) \in \text{im}PC_{\pi\bullet}.$$

Hence (45) has always a solution. To conclude the proof, it remains to show the uniqueness of this solution. Let  $\lambda_i$  and  $x_i^+$  be two solutions of the Karush–Kuhn–Tucker conditions. It follows from (45) that

$$PC_{\pi\bullet}K^{-1}\mathcal{C}_{\pi\bullet}^T P^T(\lambda_1 - \lambda_2) = 0.$$

Since  $K$  is positive definite,  $PC_{\pi\bullet}K^{-1}\mathcal{C}_{\pi\bullet}^T P^T$  is positive semidefinite and hence  $\ker PC_{\pi\bullet}K^{-1}\mathcal{C}_{\pi\bullet}^T P^T = \ker \mathcal{C}_{\pi\bullet}^T P^T$ . Therefore, one gets

$$K(x_1^+ - x_2^+) = 0.$$

from the first of the Karush–Kuhn–Tucker conditions. Since  $K$  is positive definite, this yields  $x_1^+ = x_2^+$ .

2) The expression (16) readily follows from (44a) and (45). To prove that (17) holds, observe first that (17b) immediately follows. For (17a), note that

$$x_K^+ - x_0 \in \text{im } K^{-1}C_{\pi\bullet}^T P^T$$

due to (44a). Since  $\ker P = \text{im } D_{\pi\pi}$  and  $D$  is positive semidefinite [Lemma A.1 i)], one gets  $\text{im } P^T = \ker D_{\pi\pi}^T = \ker D_{\pi\pi}$ . Hence, one has

$$x_K^+ - x_0 \in \text{im } K^{-1}C_{\pi\bullet}^T P^T = K^{-1}C_{\pi\bullet}^T \ker D_{\pi\pi}.$$

It follows from Lemma A.1 ii) that  $C_{\pi\bullet}^T \ker D_{\pi\pi} = KB_{\pi\bullet} \ker D_{\pi\pi}$  and hence

$$x_K^+ - x_0 \in K^{-1}C_{\pi\bullet}^T \ker D_{\pi\pi} = B_{\pi\bullet} \ker D_{\pi\pi}.$$

3) Let  $K_1$  and  $K_2$  are two positive definite solutions of the LMIs (10). Also let  $x_{K_1}^+$  and  $x_{K_2}^+$  be the corresponding solutions of (15). It follows from (17)

$$\begin{aligned} x_{K_i}^+ - x_0 &\in B_{\pi\bullet} \ker D_{\pi\pi} \\ C_{\pi\bullet} x_{K_i}^+ + F_{\pi\bullet} u(0) &\in \text{im } D_{\pi\pi}. \end{aligned}$$

Hence, we get

$$\begin{aligned} x_{K_1}^+ - x_{K_2}^+ &\in B_{\pi\bullet} \ker D_{\pi\pi} \\ C_{\pi\bullet} (x_{K_1}^+ - x_{K_2}^+) &\in \text{im } D_{\pi\pi}. \end{aligned}$$

Let  $K$  be any positive definite solution to the LMIs (10). The former relation, together with Lemma A.1 iii), results in

$$K (x_{K_1}^+ - x_{K_2}^+) \in (C_{\pi\bullet})^T \ker D_{\pi\pi} \quad (46)$$

whereas the latter yields

$$x_{K_1}^+ - x_{K_2}^+ \in (C_{\pi\bullet})^{-1} \text{im } D_{\pi\pi}. \quad (47)$$

where  $M^{-1}\mathcal{Y} = \{y \in \mathcal{Y} | \text{there exists } x \text{ such that } y = Mx\}$ . Since  $D$  is positive semidefinite due to passivity, we have  $\ker D_{\pi\pi} = (\text{im } D_{\pi\pi})^\perp$  where  $\perp$  denotes the orthogonal subspace. Then, basic linear algebra implies that

$$((C_{\pi\bullet})^{-1} \text{im } D_{\pi\pi})^\perp = (C_{\pi\bullet})^T \ker D_{\pi\pi}. \quad (48)$$

Thus, (46) and (47) imply that

$$(x_{K_1}^+ - x_{K_2}^+)^T K (x_{K_1}^+ - x_{K_2}^+) = 0. \quad (49)$$

As  $K$  is positive definite, we finally get

$$x_{K_1}^+ = x_{K_2}^+. \quad (50)$$

### C. Proof of Theorem VI.3

1) Note that (18) admits a solution if and only if (18c) admits a solution. Then, the claim follows from Theorem A.2 by choosing  $\mathcal{A}$ ,  $\mathcal{B}$ ,  $\mathcal{C}$ ,  $\mathcal{D}$ ,  $\mathcal{E}$ , and  $\mathcal{F}$  as in the proof of Theorem V.1.

2) Note that (19b) readily follows from Theorem A.2.1. The relations (19a) and (19c) follow from (18a), (18d), (19b), and Lemma A.1 v). ■

### D. Proof of Theorem VI.5

We know from Theorem VI.3 that (18) admits a solution  $(\hat{x}(s), \hat{z}(s), \hat{w}(s))$  where the pair  $(\hat{z}(s), \hat{w}(s))$  is proper and  $\hat{x}(s)$  is strictly proper. Let  $\hat{z}(s)$  have the expansion

$$\hat{z}(s) = z^0 + z^1 s^{-1} + z^2 s^{-2} + \dots \quad (51)$$

From (18a) and (18c), we get

$$x_L^+ = x_0 + B_{\pi\bullet} z_\pi^0 \quad (52a)$$

$$D_{\pi\pi} z_\pi^0 = 0 \quad (52b)$$

$$C_{\pi\bullet} x_0 + C_{\pi\bullet} B_{\pi\bullet} z_\pi^0 + D_{\pi\pi} z_\pi^1 + F_{\pi\bullet} u(0) = 0. \quad (52c)$$

Equivalently

$$x_L^+ - x_0 \in B_{\pi\bullet} \ker D_{\pi\pi} \quad (53a)$$

$$C_{\pi\bullet} x_L^+ + F_{\pi\bullet} u(0) \in \text{im } D_{\pi\pi}. \quad (53b)$$

Consequently, the claim follows from Theorem VI.1.2. ■

### E. Proof of Theorem VI.9

For notational simplicity, we give a proof of the case for which all switches on the links are closed and on the branches are open. The general case follows in the same lines.

Since all switches on the links are closed and on the branches are open, we get

$$v_{P_\ell}^+ = 0 \text{ and } \phi_{P_\ell} = 0 \quad (54a)$$

$$i_{P_b}^+ = 0 \text{ and } q_{P_b} = 0. \quad (54b)$$

In view of Theorem VI.1, we need to show that

$$\begin{bmatrix} v_C^+ - v_C^- \\ i_L^+ - i_L^- \end{bmatrix} \in \mathcal{B} \ker \mathcal{D} \quad (55)$$

$$\mathcal{C} \begin{bmatrix} v_C^+ \\ i_L^+ \end{bmatrix} + \mathcal{F} \begin{bmatrix} v_E^+ \\ i_J^+ \end{bmatrix} \in \text{im } \mathcal{D}. \quad (56)$$

To do so, we first claim that

$$\ker \mathcal{D} = \ker \begin{bmatrix} H_{RP_b} & 0 \\ 0 & H_{P_\ell G}^T \\ H_{P_\ell P_b} & 0 \\ 0 & H_{P_\ell P_b}^T \end{bmatrix}. \quad (57)$$

To see this, note that

$$\ker \mathcal{D} \subseteq \ker(\mathcal{D} + \mathcal{D}^T) \quad [\text{since } \mathcal{D}] \geq 0 \quad (58)$$

$$= \ker \begin{bmatrix} H_{RP_b} & 0 \\ 0 & H_{P_\ell G}^T \end{bmatrix}. \quad (59)$$

Thus, we also get

$$\ker \mathcal{D} \subseteq \begin{bmatrix} H_{P_\ell P_b} & 0 \\ 0 & H_{P_\ell P_b}^T \end{bmatrix}. \quad (60)$$

As a result,

$$\ker \mathcal{D} \subseteq \ker \begin{bmatrix} H_{RP_b} & 0 \\ 0 & H_{P_b^T G} \\ H_{P_b P_b} & 0 \\ 0 & H_{P_b^T P_b} \end{bmatrix}. \quad (61)$$

Since the reverse inclusion readily follows from the structure of  $\mathcal{D}$ , (57) holds.

To establish (55), first note that we get

$$\begin{bmatrix} \phi_{P_b} \\ -q_{P_b} \end{bmatrix} \in \ker \mathcal{D} \quad (62)$$

from the second and fourth row blocks of (27b), the first and the fourth row blocks of (27e), and (57). Then, we have

$$\mathcal{B} \begin{bmatrix} \phi_{P_b} \\ -q_{P_b} \end{bmatrix} = \begin{bmatrix} C & 0 \\ 0 & L \end{bmatrix}^{-1} \begin{bmatrix} 0 & -H_{P_b^T C} \\ -H_{LP_b} & 0 \end{bmatrix} \begin{bmatrix} \phi_{P_b} \\ -q_{P_b} \end{bmatrix}. \quad (63)$$

Since  $H_{P_b^T C} q_{P_b} = q_C$  due to the first row block of (27b) and  $-H_{LP_b} \phi_{P_b} = \phi_L$  due to the second row block of (27c), we get

$$\begin{bmatrix} v_C^+ - v_C^- \\ i_L^+ - i_L^- \end{bmatrix} = \mathcal{B} \begin{bmatrix} \phi_{P_b} \\ -q_{P_b} \end{bmatrix}. \quad (64)$$

In view of (62), this implies (55).

To establish (56), note first that

$$\text{im } \mathcal{D} = \text{im} \begin{bmatrix} H_{RP_b}^T & 0 & H_{P_b^T P_b} & 0 \\ 0 & H_{P_b G} & 0 & H_{P_b P_b} \end{bmatrix} \quad (65)$$

due to the semidefiniteness of  $\mathcal{D}$  and (57). Since

$$\mathcal{C} \begin{bmatrix} v_C^+ \\ i_L^+ \end{bmatrix} + \mathcal{F} \begin{bmatrix} v_E^+ \\ i_J^+ \end{bmatrix} + \begin{bmatrix} H_{LP_b}^T v_L^+ + H_{JP_b}^T i_J^+ \\ H_{P_b C} v_C^+ + H_{P_b E} v_E^+ \end{bmatrix} \in \text{im } \mathcal{D} \quad (66)$$

due to the structure of  $\mathcal{D}$ , it is enough to show that the last summand on the left-hand side lies in  $\text{im } \mathcal{D}$ . This, however, follows from (54) and the last row blocks of (27c) and (27f). ■

## REFERENCES

- [1] S. Seshu and N. Balabanian, *Linear Network Analysis*. New York: Wiley, 1964.
- [2] A. Dervisoglu, "State equations and initial values in active RLC networks," *IEEE Trans. Circuit Theory*, vol. CT-18, no. 5, pp. 544–547, 1971.
- [3] M. Liou, "Exact analysis of linear circuits containing periodically operated switches with applications," *IEEE Trans. Circuit Theory*, vol. 19, no. CT-2, pp. 146–154, 1972.
- [4] A. Opal and J. Vlach, "Consistent initial conditions of linear switched networks," *IEEE Trans. Circuits Syst.*, vol. 37, no. 3, pp. 364–372, Mar. 1990.
- [5] A. Opal, "The transition matrix for linear circuits," *IEEE Trans. Comput.-Aided Design Integr. Circuits Syst.*, vol. 16, no. 5, pp. 427–436, May 1997.
- [6] Q. Li and F. Yuan, "Time-domain response and sensitivity of periodically switched nonlinear circuits," *IEEE Trans. Circuits Syst. I, Fundam. Theory Appl.*, vol. 50, no. 11, pp. 1436–1446, Nov. 2003.
- [7] Z. Zuhao, "ZZ model method for initial condition analysis of dynamics networks," *IEEE Trans. Circuits Syst.*, vol. 38, no. 8, pp. 937–941, Aug. 1991.
- [8] A. Massarini, U. Reggiani, and M. K. Kazimierzczuk, "Analysis of networks with ideal switches by state equations," *IEEE Trans. Circuits Syst. I, Fundam. Theory Appl.*, vol. 44, no. 8, pp. 692–697, Aug. 1997.
- [9] B. De Kelper, L. A. Dessaint, K. Al-Haddad, and H. Nakra, "A comprehensive approach to fixed-step simulation of switched circuits," *IEEE Trans. Power Electron.*, vol. 17, no. 2, pp. 216–224, Mar. 2002.
- [10] Y. Murakami, "A method for the formulation and solution of circuits composed of switches and linear RLC elements," *IEEE Trans. Circuits Syst.*, vol. 34, no. 5, pp. 496–509, May 1987.
- [11] J. Tolsa and M. Salichs, "Analysis of linear-networks with inconsistent initial conditions," *IEEE Trans. Circuits Syst. I, Fundam. Theory Appl.*, vol. 40, no. 12, pp. 885–894, Dec. 1993.
- [12] A. Opal and J. Vlach, "Consistent initial conditions of nonlinear networks with switches," *IEEE Trans. Circuits Syst.*, vol. 38, no. 7, pp. 698–710, Jul. 1991.
- [13] J. Vlach, J. M. Wojciechowski, and A. Opal, "Analysis of nonlinear networks with inconsistent initial conditions," *IEEE Trans. Circuits Syst. I, Fundam. Theory Appl.*, vol. 42, no. 4, pp. 195–200, Apr. 1995.
- [14] A. Opal, "Sampled data simulation of linear and nonlinear circuits," *IEEE Trans. Comput.-Aided Design Integr. Circuits Syst.*, vol. 15, no. 3, pp. 295–307, Mar. 1996.
- [15] F. Del Aguila Lopez, P. Schonwilder, J. Dalmau, and R. Mas, "A discrete-time technique for the steady state analysis of nonlinear switched circuits with inconsistent initial conditions," in *IEEE Int. Symp. Circuits Syst.*, 2001, vol. 3, pp. 357–360.
- [16] I. C. Goknar, "Conservation of energy at initial time for passive RLC network," *IEEE Trans. Circuit Theory*, vol. CT-19, no. 4, pp. 365–367, Jul. 1972.
- [17] P. Mayer, J. Jeffries, and G. Paulik, "The two-capacitor problem reconsidered," *IEEE Trans. Educ.*, vol. 36, no. 3, pp. 307–309, Aug. 1993.
- [18] A. M. Sommariva, "Solving the two capacitor paradox through a new asymptotic approach," *IEE Proc. Circuits Devices Syst.*, vol. 150, no. 3, pp. 227–231, 2003.
- [19] D. G. Bedrosian and J. Vlach, "Time-domain analysis of networks with internally controlled switches," *IEEE Trans. Circuits Syst. I, Fundam. Theory Appl.*, vol. 39, no. 3, pp. 199–212, Mar. 1992.
- [20] M. K. Camlibel, W. P. M. H. Heemels, and J. M. Schumacher, "On the dynamic analysis of piecewise-linear networks," *IEEE Trans. Circuits Syst. I, Fundam. Theory Appl.*, vol. 49, no. 3, pp. 315–327, Mar. 2002.
- [21] M. K. Camlibel, W. P. M. H. Heemels, A. J. van der Schaft, and J. M. Schumacher, "Switched networks and complementarity," *IEEE Trans. Circuits Syst. I, Fundam. Theory Appl.*, vol. 50, no. 8, pp. 1036–1046, Aug. 2003.
- [22] F. Vasca, L. Iannelli, M. K. Camlibel, and R. Frasca, "A new perspective for modeling power electronics converters: Complementarity framework," *IEEE Trans. Power Electron.*, vol. 24, no. 2, pp. 465–468, Feb. 2009.
- [23] S.-C. Tan, S. Bronstein, M. Nur, Y. Lai, A. Ioinovici, and C. Tse, "Variable structure modeling and design of switched-capacitor converters," *IEEE Trans. Circuits Syst. I, Reg. Papers*, vol. 56, no. 9, pp. 2132–2142, Sep. 2009.
- [24] J. Ruiz-Amaya, M. Delgado-Restituto, and A. Rodriguez-Vazquez, "Accurate settling-time modeling and design procedures for two-stage miller-compensated amplifiers for switched-capacitor circuits," *IEEE Trans. Circuits Syst. I, Reg. Papers*, vol. 56, no. 6, pp. 1077–1087, Jun. 2009.
- [25] Y. Wang, M. Yang, H. Wang, and Z. Guan, "Robust stabilization of complex switched networks with parametric uncertainties and delays via impulsive control," *IEEE Trans. Circuits Syst. I, Reg. Papers*, vol. 56, no. 6, pp. 2100–2108, Jun. 2009.
- [26] F. del-Águila López, P. Palà-Schönwälder, P. Molina-Gaudó, and A. Mediano-Heredia, "A discrete-time technique for the steady-state analysis of nonlinear class-E amplifiers," *IEEE Trans. Circuits Syst. I, Reg. Papers*, vol. 54, no. 6, pp. 1358–1366, Jun. 2007.
- [27] K. M. Gerritsen, A. J. van der Schaft, and W. P. M. H. Heemels, "On switched Hamiltonian systems," presented at the 15th Int. Symp. Math. Theory Netw. Syst., South Bend, IN, 2002.
- [28] J. C. Willems, "Dissipative dynamical systems part I: General theory," *Arch. Ration. Mech. Anal.*, vol. 45, no. 5, pp. 321–351, 1972.
- [29] J. J. Moreau, "Quadratic programming in mechanics: Dynamics of one-sided constraints," *SIAM J. Control*, vol. 4, pp. 153–158, 1966.
- [30] J. J. Moreau, "Liaisons unilaterales sans frottement et chocs inélastiques," *C. R. Acad. Sci., Paris, Ser. II*, vol. 296, no. 19, pp. 1473–1476, 1983.
- [31] J. J. Moreau, "Unilateral contact and dry friction in finite freedom dynamics," in *Nonsmooth Mechanics and Applications*, ser. CISM Courses and Lectures, J. Moreau and P. Panagiotopoulos, Eds. Wien, New York: Springer-Verlag, 1988, vol. 302, pp. 1–82.
- [32] M. K. Camlibel, L. Iannelli, and F. Vasca, "Passivity and complementarity," *Math. Program. A*, 2008, submitted for publication.

- [33] S. Boyd, L. E. Ghaoui, E. Feron, and V. Balakrishnan, *Linear Matrix Inequalities in System and Control Theory*, ser. Studies in Applied Mathematics 15. Philadelphia, PA: SIAM, 1994.
- [34] J. Vlach and K. Singhal, *Computer Methods for Circuit Analysis and Design*. Dordrecht, The Netherlands: Kluwer Academic, 2003.
- [35] C. Desoer and E. Kuh, *Basic Circuit Theory*. New York: McGraw-Hill, 1969.
- [36] L. O. Chua, C. A. Desoer, and E. S. Kuh, *Linear and Nonlinear Circuits*. New York: McGraw-Hill, 1987.
- [37] W. P. M. H. Heemels, J. M. Schumacher, and S. Weiland, "The rational complementarity problem," *Linear Algebr. Its Appl.*, vol. 294, no. 1–3, pp. 93–135, 1999.
- [38] O. Mangasarian, *Nonlinear Programming*. New York: McGraw-Hill, 1969.



**Roberto Frasca** (S'05-M'08) was born in Benevento, Italy, in 1976. He received the M.S. degree in electronic engineering from the Università di Napoli Federico II, Naples, Italy, in 2003 and the Ph.D. degree in Automatic Control from the Università del Sannio, Benevento, Italy, in 2007.

In 2006 and 2007, he was a Visiting Scholar at the Department of Mechanical Engineering—Dynamics and Control, Eindhoven University of Technology, The Netherlands. Since 2008 he has been with AnsaldoBreda SpA, Naples, as a Propulsion System

Designer. His research interests include modeling and design of power electronic converters, rapid control prototyping, and hardware in the loop simulations.



**M. Kanat Camlibel** was born in Istanbul, Turkey, in 1970. He received the B.Sc. and M.Sc. degrees in control and computer engineering from the Istanbul Technical University, Istanbul, Turkey, in 1991 and 1994, respectively, and the Ph.D. degree from Tilburg University, Tilburg, The Netherlands, in 2001.

Between 2001 and 2007, he held postdoctoral positions at the University of Groningen and Tilburg University, Assistant Professor positions at Dogus University, Istanbul, and Eindhoven University of Technology. Since 2007, he has been an Assistant Pro-

fessor at the University of Groningen, The Netherlands. He is a Subject Editor for the *International Journal of Robust and Nonlinear Control*. His main research interests include the analysis and control of nonsmooth dynamical systems, in particular piecewise linear and complementarity systems.



**I. Cem Goknar** (S'66–M'71–SM'77–F'05) was born in Istanbul, Turkey. He received the B.Sc. and M.Sc. degrees from Istanbul Technical University, Turkey, and the Ph.D. degree from Michigan State University, East Lansing, in 1969.

He was a Visiting Professor at the University of California, Berkeley; University of Illinois at Urbana-Champaign; University of Waterloo, Canada; Technical University of Denmark at Lyngby; and a Full Professor at Istanbul Technical University from 1979 to 2000. Currently he is a Professor, and was

the Electronics and Communications Engineering Department Founding Head, at Dogus University, Istanbul, Turkey.

Prof. Goknar is a Member of European Circuit Society Council, a Member of the IEEE Technical Committee on Nonlinear Circuits and Systems, and IEEE-CAS Chapter Chair, Turkey Section.



**Luigi Iannelli** (S'01–M'03) was born in Benevento, Italy, in 1975. He received the Laurea degree in computer engineering from the University of Sannio, Benevento, in 1999, and the Ph.D. degree in information engineering from the University of Napoli Federico II, Naples, Italy, in 2003.

During 2002 and 2003 he visited, as a Guest Researcher, the Department of Signals, Sensors, and Systems, Royal Institute of Technology, Stockholm, Sweden. He was a Research Assistant at the Dipartimento di Informatica e Sistemistica, University

of Napoli Federico II, and since 2004, he has been an Assistant Professor of Automatic Control with the Department of Engineering, University of Sannio, Benevento. His current research interests include analysis and control of switched and nonsmooth systems, and automotive control and applications of control theory to power electronics.

Dr. Iannelli is a Member of the IEEE Control Systems Society, the IEEE Circuits and Systems Society, and the Society for Industrial and Applied Mathematics.



**Francesco Vasca** (S'94–M'95) was born in Giugliano, Napoli, Italy, in 1967. He received the M.Sc. and Ph.D. degrees in Electronic and Automatic Control Engineering from the University of Napoli Federico II, Italy, in 1991 and 1995, respectively.

Since 2000 he has been an Associate Professor of Automatic Control with the Department of Engineering, University of Sannio, Benevento, Italy. His research interests include automotive control, modeling and control for power converters, and averaging of switched systems through dithering.

Prof. Vasca is currently an Associate Editor for the IEEE TRANSACTIONS ON CONTROL SYSTEMS TECHNOLOGY.