

NASA Technical Memorandum 88805

NASA-TM-88805 19870004993

Liquid Oxygen Cooling of High Pressure LOX/Hydrocarbon Rocket Thrust Chambers

Harold G. Price and Philip A. Masters
Lewis Research Center
Cleveland, Ohio

August 1986

LIBRARY COPY

OCT 23 1986

LANGLEY RESEARCH CENTER
LIBRARY, NASA
HAMPTON, VIRGINIA

NASA

LIQUID OXYGEN COOLING OF HIGH PRESSURE LOX/HYDROCARBON

ROCKET THRUST CHAMBERS

Harold G. Price and Philip A. Masters
National Aeronautics and Space Administration
Lewis Research Center
Cleveland, Ohio 44135

SUMMARY

An experimental program using liquid oxygen (LOX) and RP-1 as the propellants and supercritical LOX as the coolant was conducted at 4.14, 8.27, and 13.79 MN/m² (600, 1200, and 2000 psia) chamber pressure. The objectives of this program were to evaluate the cooling characteristics of LOX with the LOX/RP-1 propellants, the buildup of soot on the hot-gas-side chamber wall and the effect of an internal LOX leak on the structural integrity of the combustor.

Five thrust chambers with throat diameters of 6.6 cm (2.6 in.) were tested successfully. The first three were tested at 4.14 MN/m² (600 psia) chamber pressure over a mixture ratio range of 2.25 to 2.92. One of these three was tested for over 22 cyclic tests after the first through crack from the coolant channel to the combustion zone was observed with no apparent metal burning or distress. The fourth chamber was tested at 8.27 MN/m² (1200 psia) chamber pressure over a mixture ratio range of 1.93 to 2.98. The fourth and fifth chambers were tested at 13.79 MN/m² (2000 psia) chamber pressure over a mixture ratio range of 1.79 to 2.68.

INTRODUCTION

Preliminary design studies by NASA and its contractors (refs. 1 to 4) for vehicles such as the mixed-mode, single-stage-to-orbit (SSTO), and the heavy lift launch vehicle (HLLV), have shown a requirement for a new high pressure (27.58 MN/m² - 4000 psia chamber pressure) booster engine using a hydrocarbon fuel and oxygen for propellants. Furthermore, ongoing studies are evaluating hydrocarbon fueled propulsion systems applicable to operations for a quick response, highly maneuverable launch vehicle. These systems would ultimately lead to a truly economical means of accomplishing many of the space missions envisioned in the 1990 time period and beyond. The candidate hydrocarbon fuels for these assumed systems appear to be RP-1, propane, and methane. One specific hydrocarbon fuel or propulsion system has not been selected at this time.

One characteristic of LOX/RP-1 and LOX/propane combustion over the mixture range (O/F) of interest is the formation of soot and the buildup of a carbon layer along the hot thrust chamber wall. This carbon layer acts as an insulator reducing the heat transfer into the combustor walls. The carbon layer thickness will vary with different axial locations and may be affected by chamber pressure level and by the start and shutdown sequences of the test firings. A reasonable assumption, supported by experimental evidence, relating to hot gas deposits is that an equilibrium is reached between the depositing layer and that which is being eroded away. There is evidence that chemical reaction plays a significant role in determining the equilibrium when molecular

E-3149

787-17426 #

and/or atomic oxygen is present in the hot gas stream. However, some deposit would likely flake off the wall by the erosion effect of the gas moving over the deposit surface resulting in hot spots.

The requirements for a very high chamber pressure, (very high heat flux) hydrocarbon fueled rocket engine has necessitated that the engine designer consider evaluating the cooling capability of both the fuel and the oxidizer. An inherent disadvantage of RP-1 and even the lighter paraffinic hydrocarbon propane, is the tendency for these hydrocarbons to undergo decomposition (coking) in the coolant passages. They form barrier coatings from the decomposition (coking), thereby greatly reducing their cooling capability. A further complication with hydrocarbon propellant cooling recently identified in reference 5 is the corrosion of copper by chemical attack caused by trace metallic impurities in the fuel.

Because of the coking cooling limitation and chemical attack problems associated with using a hydrocarbon as the regenerative coolant, it is necessary to consider the oxidant (oxygen) as a possible coolant option for the advanced LOX-hydrocarbon engine. Supercritical liquid oxygen is a desirable heat transfer candidate due to its generally favorable thermodynamic and transport properties. However, a concern with the use of oxygen as a coolant is what would happen if a through-crack formed in the wall allowing oxygen to enter the combustor. One hypothesis offered is that the oxygen upon entering the combustion chamber through the crack could potentially oxidize the carbon layer or react with the fuel rich combustor products which in turn could heat the thrust chamber wall to its ignition temperature and cause a catastrophic failure. Another scenario offered is that the LOX entering through the crack would film-cool the carbon layer with no oxidation of either the carbon layer or the metal wall.

The purposes of the present program were to evaluate the cooling characteristics of liquid oxygen with LOX/RP-1 propellants, determine the buildup of soot on the hot-gas-side chamber wall, and observe the effect of an internal LOX leak on the structural integrity of the combustor.

This program focused on LOX/RP-1 propellant combustion and achieved test results at a chamber pressure approximately half the chamber pressure of an advanced system. The effort concentrated on the design and test of small thrust chambers (22 241 to 75 619 N - 5000 to 17 000 lbs force thrust) and involved developing procedures for smooth starts and shutdowns and the design of resonator hardware for combustion stability as well as injectors to assess combustion efficiency comparisons.

A series of experimental tests in which soot deposit on the wall was determined were conducted at 4.14, 8.27, and 13.79 MN/m² (600, 1200, and 2000 psia) chamber pressure with LOX/RP-1 as the propellants and using LOX as the coolant. The 4.14 MN/m² (600 psia) chamber pressure tests covered an O/F range of 2.2 to 2.9, the 8.27 MN/m² (1200 psia) chamber pressure tests covered an O/F range of 1.9 to 3.0 and the 13.79 MN/m² (2000 psia) chamber pressure tests covered an O/F range of 1.8 to 2.7. To evaluate the effect of a LOX leak on structural integrity, a cyclic hot fire test series at 4.14 MN/m² (600 psia) chamber pressure was conducted until a crack developed in the hot gas wall.

HEAT TRANSFER CORRELATION

Heat transfer to supercritical oxygen has been investigated (ref. 6) with a series of heated tubes at high pressures ranging from 17 to 34.5 MN/m² (2460 to 5000 psia) and bulk temperature of 96 to 217 K (173 to 391 °R). From this test data and previously existing data (refs. 7 and 8) which increased the range from 2 to 34.5 MN/m² (290 to 5000 psia) and bulk temperature of 96 to 566 K (173 to 1019 °R), a multiple regression analysis was conducted as part of the work done in reference 6 which led to the following design correlation for calculating supercritical oxygen heat transfer coefficients:

$$Nu_b = 0.0025 Re_b Pr_b^{0.4} \left(\frac{P_b}{P_w}\right)^{-1/2} \left(\frac{K_b}{K_w}\right)^{1/2} \left(\frac{\overline{Cp}}{Cp_b}\right)^{2/3} \left(\frac{P_b}{P_{cr}}\right)^{-1/5} \left(1 + \frac{2}{L/D}\right)$$

where

Cp constant pressure specific heat

\overline{Cp} integrated average specific heat from T_w to T_b

D inside tube diameter

h heat transfer coefficient

K thermal conductivity

L heated tube length

Nu Nusselt number, hD/K

P pressure (local static)

Pr Prandtl number, $Cp \mu/K$

Re Reynolds number, $\rho DV/\mu$

T temperature

V fluid velocity

μ viscosity

ρ density

Subscripts:

b evaluated at bulk temperature

cr critical state

w evaluated at wall temperature

The thrust chambers used in this investigation were designed and fabricated using this cooling side heat transfer correlation. Refer to reference 9 for design details. This correlation was validated by the work of reference 10, where the measured wall temperatures agreed with the analytically predicted wall temperature.

APPARATUS AND PROCEDURES

Injectors

A typical injector used in this program (ref. 11) at 4.14 MN/m^2 (600 psia) chamber pressure is shown in figure 1. This injector is a 37 element oxidizer-fuel-oxidizer triplet injector with an impingement half angle of the oxidizer onto the fuel of 30° . The triplet element pattern was arranged to provide mutually perpendicular LOX fans.

To obtain a more uniform flow distribution behind the injector face for the higher chamber pressures, a 61 element injector as shown in figure 2 was used for the 8.27 MN/m^2 (1200 psia) chamber pressure testing. This injector was originally fabricated with the 61 elements as triplets arranged in a pattern to provide LOX tangential fans. However, this injector pattern resulted in a high temperature of the hot-gas wall. As a result, the injector was modified in the outer ring of elements by welding closed all the holes and then redrilling the fuel holes and inner LOX holes as showerheads. The outer zone then consisted of 24 fuel holes and 24 oxidant holes. This pattern provided 25 percent of the total fuel flow and 13 percent of the oxygen flow in the outer zone. At an overall O/F of 2 there was an O/F of 1.03 in the outer zone and an O/F of 2.32 in the core.

Figure 3 shows a 61 element injector used for the 13.79 MN/m^2 (2000 psia) chamber pressure testing. This injector was modified in the outer ring of elements as the 8.27 MN/m^2 (1200 psia) chamber pressure injector was. The outer ring of elements were welded closed and the fuel holes and inner LOX holes redrilled as showerheads. This pattern provided 30 percent fuel flow in the outer zone and 18 percent oxygen in the outer zone. At an overall O/F of 2, there was an O/F of 1.18 in the outer zone and an O/F of 2.35 in the core.

The hole sizes, areas, and pressure drops for the three injectors are shown in table I.

Combustion Chambers

The thrust chamber hot gas liners were fabricated of an oxygen-free, high-conductivity (OFHC) copper and contained 100 axial milled slots for the coolant passages. The passages were closed out with electroformed nickel. The details of the coolant channel dimensions are given in reference 9.

Because of the higher heat releases at 8.27 MN/m^2 (1200 psia) and 13.79 MN/m^2 (2000 psia) chamber pressure, a shorter combustion chamber was used at these chamber pressures than at 4.14 MN/m^2 (600 psia) chamber pressure. The dimensions of the thrust chambers are shown in figure 4 and table II.

Five thrust chambers were used during this program. A photograph of a chamber in the test stand being fired vertically downward is shown in figure 5. A photograph of a chamber, resonator, and injector is shown in figure 6. The thrust chambers were instrumented with Chromel/Constantan thermocouples imbedded in the rib between coolant channels approximately 1.27 mm (0.05 in.) from the hot gas wall as described in reference 12. All of the chambers had 16 thermocouples evenly spaced circumferentially in 4 axial positions, 2 upstream of the throat, 1 at the throat, and 1 downstream of the throat. In the shorter chambers, the two planes upstream of the throat were at 16.5 and 26.0 cm (6.5 and 10.25 in.), the throat was 29.2 cm (11.5 in.), and the downstream plane was 31.8 cm (12.5 in.) from the injector face. In the longer chambers the 2 planes upstream of the throat were at 26.0 and 36.2 cm (10.25 and 14.25 in.), the throat was 39.4 cm (15.5 in.), and the downstream plane was 41.9 cm (16.5 in.) from the injector face. These positions provide temperature instrumentation in the cylindrical, convergent, throat, and divergent portions of the thrust chamber. The instrumentation can be seen in the thrust chamber portion of figure 6.

Resonators

A water-cooled resonator, as shown in the middle portion of figure 6, was used in this investigation to provide stable combustion. It was composed of 16 cavities arranged evenly around its inside surface. The resonator was coaxial with, and placed between the chamber and the injector. The cavities were in line with the thrust chamber at its edge and were 3.63 cm (1.43 in.) long. The injector formed the inner wall of the cavities which were 2.54 cm (1 in.) long (see fig. 4). This corresponded to a quarter wave tube to dampen the second tangential frequency of 9700 cycles/sec which was the expected frequency of the combustion oscillations causing the instability. The same type of resonator had been used in the work described in reference 13.

Igniter

Propellant ignition was accomplished with a hydrogen/oxygen spark torch igniter inserted through the resonator wall just downstream of the cavities. This igniter was started just prior to the main propellant flow and supplied the energy necessary to start the LOX/RP-1 combustion. After LOX/RP-1 combustion was initiated the torch flows were turned off and a small inert purge gas flow started to prevent hot combustion gas from backing up into the igniter.

Test Facility and Procedures

This program was conducted in a 222 410 N (50 000 lbf) thrust, sea-level rocket test stand equipped with an exhaust-gas muffler and scrubber. The facility used pressurized propellant storage tanks to supply the propellants to the combustion chamber. The propellants were liquid oxygen (LOX) and ambient-temperature RP-1. A separate source of LOX was used as the coolant. Installation of the thrust chamber on the facility thrust stand can be seen in figure 7.

Two types of tests, cyclic and steady state, were performed during this program. In the cyclic tests, the chamber was brought up to the desired pres-

sure and maintained at that pressure for 0.5 sec and then the propellant valves were closed for a duration of 2 sec. The fuel valve was closed first to avoid fuel contamination of the LOX portion of the injector when cyclic tests were performed. This was followed immediately by a second cycle to the same operating condition. As many as 25 consecutive cycles at a time were performed in this manner. The LOX coolant flow continued during both firing and nonfiring portions of the cycle. This type of test was used to first produce a crack in to the combustion chamber and then to investigate the effect of a LOX leak through the crack on thrust chamber wall integrity with the chamber still firing.

In the steady-state tests, the pressure was brought up in the chamber and maintained at the desired level for a duration from 1.3 to 10 sec. The heat transfer information was obtained from this type of test. The thermocouples imbedded in the channel ribs reached steady values in approximately 1 sec and remained constant while the data were recorded.

Test cycles were programmed into a solid-state timer that was accurate and repeatable to within ± 0.001 sec. Fuel and oxidizer flows were controlled by fixed-position valves and propellant tank pressure. Coolant inlet pressure was controlled by coolant tank pressure. Coolant exit pressure was kept constant by a closed-loop controller modulating a back pressure valve. With this arrangement, the coolant flow rate started high and decreased to the desired value as the final combustion conditions were reached. The coolant was vented after use.

Control room operation of the test included monitoring of the test hardware by means of three closed-circuit television cameras. The output of one television camera was recorded on magnetic tape for later playback.

Data was recorded every 0.02 sec, averaged over five recordings, and the average reported every 0.10 sec.

TEST RESULTS

Test Conditions

Five thrust chambers were tested during this program. The conditions for these tests are shown in table II. Chambers S/N 1, 2, and 3 were operated at 4.14 MN/m^2 (600 psia) chamber pressure. Chamber S/N 4 was operated at 8.27 MN/m^2 (1200 psia) chamber pressure and chamber S/N 4 and 5 were operated at 13.79 MN/m^2 (2000 psia) chamber pressure. One of these thrust chambers (S/N 3) was cyclically tested until a crack through the cooling channel to the combustion chamber was observed. The crack developed sometime between the 42nd and 71st cycle. It was further tested until 93 cycles had been accumulated. At this time testing was stopped, but further tests could have been run. Chamber S/N 1 was tested 9 times, chamber S/N 2 - 13 times, chamber S/N 4 - 31 times, and chamber S/N 5 - 1 time. Only chamber S/N 3 developed a crack. Thus, successfully cooling with LOX was demonstrated with no catastrophic failures.

Injector Performance

Figure 8 is a plot of the C^* efficiency which was determined from chamber pressure versus the mixture ratio tested. The measured performance of three different injectors are plotted on this graph. The differences in these injectors were explained in the Injector section.

Except for some data scatter, it can be seen that the 4.14 MN/m² (600 psia) injector developed over 99 percent efficiency, the 8.27 MN/m² (1200 psia) injector 95 percent efficiency, and the 13.79 MN/m² (2000 psia) injector 96 percent efficiency. The lower efficiency for the two higher chamber pressures resulted from the injector modifications to reduce the wall temperatures and the shorter chamber lengths. Reference 14 gives a further explanation of why zone cooling of a rocket thrust chamber can reduce the injector efficiency.

Soot Thickness Analysis

Because of uncertainty of effects of startup and shutdown on soot deposition, an analytical approach was utilized to determine the deposit thickness. A calculation was performed to predict the temperature distribution in the thrust chamber walls at the four axial locations where the instrumentation was located. This was done with a modified SINDA (a two-dimensional, finite difference, relaxation heat transfer) computer code for a slotted copper liner configuration with an electroformed nickel close-out as the thrust chambers used in this program were fabricated. The predictions were performed at the chamber pressure and mixture ratio operating conditions that were experimentally run. A value of 0.00125 cal/cm sec °C (7×10^{-6} BTU/in. sec °F) was used for the thermal conductivity of soot. The axial locations were in the cylindrical section, the converging section, the throat, and the diverging section. A soot coating of various (1, 2, and 3 mils, i.e., 0.001, 0.002, and 0.003 in.) thickness was assumed on the hot gas wall. From these calculations, figures 9(a) to (e) for the cylindrical section, figures 10(a) to (e) for the converging, figures 11(a) to (e) for the throat, and figures 12(a) to (e) for the diverging section were constructed showing the predicted wall temperature at the location of the rib thermocouples for various soot deposit thicknesses. Then the plot was entered with the experimentally measured rib temperature and the soot thickness determined.

Figures 13(a) to (e) is a plot of the soot thickness at the various chamber axial locations for the chamber pressure and mixture ratio range experimentally covered in this investigation.

Figures 14(a) to (d) shows the soot thickness over the chamber pressure range covered at an O/F of nominally 2.8. Figure 14(a) shows the soot thickness in the cylindrical portion of the chamber to be uniform at 4 mils thick. Figure 14(b) shows that in the convergent section, the soot thickness decreases from 2 mils at 4.14 MN/m² (600 psia) chamber pressure down to 0 thickness at 13.79 MN/m² (2000 psia) chamber pressure. Figure 14(c) shows the same conditions at the throat over the pressure range, and figure 14(d) indicates that the soot thickness decreases from around 4 mils at 4.14 MN/m² (600 psia) down to 1 mil at 13.79 MN/m² (2000 psia) chamber pressure in the divergent section.

Figures 15(a) to (d) shows the soot thickness over the mixture ratio range covered at a nominal chamber pressure of 8.27 MN/m² (1200 psia). Figure 15(a) shows the soot thickness in the cylindrical portion of the chamber to decrease from 6.5 mils thick at an O/F of nominally 2 down to a thickness of 4 mils at an O/F of nominally 3. Figure 15(b) shows that in the convergent section, the soot thickness decreases from just over 2 mils at an O/F of nominally 2 down to a thickness of 1 mil at an O/F of nominally 3. Figure 15(c) shows that at the throat the thickness varies from 1.5 mils at an O/F of nominally 2 down to a thickness of just over 0.5 mil at an O/F of nominally 3. Finally, in the diverging section figure 15(d) shows that the thickness varies from 3 mils at an O/F of nominally 2 down to a thickness of 1.5 mils at an O/F of nominally 3.

Effects of LOX Leaks on the Thrust Chamber Integrity

Cyclic test operation was performed to determine what effect a crack in the combustion chamber wall would have if it allowed oxygen to enter the combustion zone. It was postulated that there would be no effect if the metal wall were maintained below its ignition temperature. From table II it can be seen that one of the chambers was operated until cracks developed. These cracks were in the throat region. Leakage through these cracks was very evident by observing the large amounts of vapors leaving the chamber between cycles and at the beginning of the tests. This was particularly true from cycle 71 to 93 after the cracks had been visually identified. The chamber showed no signs of apparent metal burning or distress. In fact, upon post inspection the lack of discoloration revealed that the area around the crack was overcooled by the leaking oxygen. This was also observed in thrust chamber tests with cracks in which hydrogen was used as the coolant, and thrust chamber tests with cracks in which LOX was used to cool hydrogen/oxygen propellants (ref. 10). There was no catastrophic failure.

CONCLUDING REMARKS

The present phase of the LOX cooling program has demonstrated that supercritical LOX is capable of cooling thrust chambers using LOX/RP-1 as the combustion propellants. These propellants were thought to perhaps present a more severe operating environment if a small crack developed in the chamber wall because of the presence of a soot layer. The concern was that the leaking coolant, LOX, entering the combustion chamber through the crack, could oxidize the soot film which could in turn heat the chamber wall to its ignition temperature. From the soot analysis at the 4.14 MN/m² (600 psia) chamber pressure, a soot layer was indeed present in the area where the cracks developed (the throat), however, this did not aggravate the situation. The metal wall was maintained below its ignition temperature and no catastrophic failure resulted.

SUMMARY OF RESULTS

Five thrust chambers with identical coolant passage geometries were tested with LOX/RP-1 as the propellants and LOX as the coolant. Three of these thrust chambers were tested at 4.14 MN/m² (600 psia) chamber pressure and over a mixture ratio range of 2.25 to 2.92. One thrust chamber was tested at 8.27 MN/m²

(1200 psia) chamber pressure over a mixture range of 1.93 to 2.98. Two of the thrust chambers were tested at 13.79 MN/m² (2000 psia) chamber pressure over a mixture ratio range of 1.79 to 2.68. The results of these tests were as follows:

1. Successful cooling with LOX was demonstrated.
2. One chamber was cyclically tested 93 times. During this testing, cracks appeared in the hot-gas wall that permitted oxygen to flow into the combustion region with no catastrophic failures. With this chamber, more than 22 cyclic tests were made after the first through-crack was observed with no apparent metal ignition or distress.
3. The LOX passing through the crack in the hot-gas wall did not react with the carbon layer at the throat on the combustion wall, thereby, raising the metal wall temperature to its ignition temperature and causing a catastrophic failure. It also did not react directly with the metal wall.
4. The thrust chamber wall cracks that formed as a result of the cyclic testing with LOX as the coolant, appeared to have similar characteristics as those from a previous program where liquid hydrogen was the coolant.
5. The LOX cooling of LOX/RP-1 propellants was very similar to the LOX cooling of hydrogen/oxygen propellants.
6. At a nominal O/F of 2.8, soot thickness decreases as chamber pressure increases, except in the cylindrical portion of the thruster where it remained a constant thickness.
7. Soot deposition was the least in the throat region at all chamber pressures and mixture ratios.
8. Soot thickness decreased at a given thrust chamber axial location as mixture ratio increased in the range from two to three.

REFERENCES

1. Luscher, W.P.; and Mellish, J.A.: Advanced High Pressure Engine Study for Mixed-Mode Vehicle Applications. NASA CR-135141, 1977.
2. Haefeli, R.C., et al.: Technology Requirements for Advanced Earth-Orbital Transportation Systems. NASA CR-2866, 1977.
3. Hepler, A.K.; and Bangsund, E.L.: Technology Requirements for Advanced Earth Orbital Transportation Systems. NASA CR-2878, 1978.
4. Caluori, V.A.; Conrad, R.T.; and Jenkins, J.C.: Technology Requirements for Future Earth-to-Geosynchronous Orbit Transportation Systems. NASA CR-3265, 1980.
5. Giovantetti, A.J.; Spadaccini, L.J.; and Szetela, E.J.: Deposit Formation and Heat Transfer in Hydrocarbon Rocket Fuels. (R83-956152-10, United Technologies Research Center; NASA Contract NAS3-23344) NASA CR-168277, 1983.

6. Spencer, R.G.; and Rousar, D.C.: Supercritical Oxygen Heat Transfer, NASA CR-135339, 1977.
7. Rousar, D.C.; and Miller, E.: Cooling with Supercritical Oxygen. AIAA Paper 75-1248, September 1975.
8. Powell, W.B.: Heat Transfer to Fluids in the Region of the Critical Temperature. Jet Propulsion Laboratory, JPL-PR-20-285, 1956.
9. Spencer, R.G.; Rousar, D.C.; and Price, H.G.: LOX-Cooled Thrust Chamber Technology Developments, AIAA Paper 78-1035, July 1978.
10. Price, H.G.: Cooling of High Pressure Rocket Thrust Chambers with Liquid Oxygen. AIAA Paper 80-1260, June 1980.
11. Pavli, A.J.: Design Evaluation of High Performance Rocket Engine Injectors for Use with Hydrocarbon Fuels. NASA TM-79319, 1979.
12. Hannum, N.P.; Kasper, H.J.; and Pavli, A.J.: Experimental and Theoretical Investigation of Fatigue Life in Reusable Rocket Thrust Chambers. AIAA Paper 76-685, July 1976.
13. LaBotz, R.J.; Rousar, D.C.; and Valler H.W.: High Density Fuel Combustion and Cooling Investigation. NASA CR-165177, 1980.
14. Winter, J.M.; Pavli, A.J.; and Shinn, A.M., Jr.: Design and Evaluation of an Oxidant-Fuel-Ratio-Zoned Rocket Injector for High Performance and Ablative Engine Compatibility. NASA TN D-6918, 1972.

TABLE I. - INJECTOR HOLES SIZES, AREAS, AND PRESSURE DROPS

Injector number	Number of elements	Pattern	Fuel hole diameter, mm (in.)			Fuel area, mm ² (in. ²)			LOX hole diameter, mm (in.)			LOX area, mm ² (in. ²)			ΔP at O/F = 2.8	
			24 Outer holes	36 Core holes	1 Center hole	Outer	Core	Center	24 Outer holes	72 Core holes	3 Center holes	Outer	Core	Center	Fuel MN/m ² (psid)	LOX MN/m ² (psid)
1	37	Triplet 0-F-0 LOX fans mutually perpendicular	1.702 (0.067)			84.129 (0.1304)			1.489 (0.059)			130.5 (0.2023)			0.414 (60)	1.311 (190)
2	61	Triplet 0-F-0 Tangential LOX fans	Zone hole diameters			Zone hole areas			Zone hole diameters			Zone hole areas			1.932 (280)	4.071 (590)
			24 Outer holes	36 Core holes	1 Center hole	Outer	Core	Center	24 Outer holes	72 Core holes	3 Center holes	Outer	Core	Center		
			1.168 (0.046)	1.600 (0.063)	1.600 (0.063)	25.715 (0.040)	72.382 (0.112)	2.011 (0.0031)	1.168 (0.046)	1.702 (0.067)	1.397 (0.055)	25.735 (0.040)	163.74 (0.254)	4.581 (0.0071)		
3	61	Triplet 0-F-0 Tangential LOX fans	24 Outer holes	36 Core holes	1 Center hole	Outer	Core	Center	24 Outer holes	72 Core holes	3 Center holes	Outer	Core	Center	ΔP at O/F = 2.65	
			1.626 (0.064)	2.007 (0.079)	2.007 (0.079)	49.806 (0.077)	113.89 (0.177)	3.164 (0.0049)	1.588 (0.062)	1.950 (0.077)	1.702 (0.067)	47.534 (0.073)	216.32 (0.335)	6.839 (0.011)	2.346 (340)	4.485 (650)

TABLE II. - TEST CONDITIONS AND HISTORY

Chamber, S/N	Chamber length injector to throat, cm, (in.)	Nominal chamber pressure, MN/m ² (psia)	Nominal mixture ratio range	Number of cycles thrust chamber tested	Nominal coolant flow rate, kg/sec, (lb/sec)	Nominal coolant inlet pressure, MN/m ² (psia)	Nominal coolant outlet pressure, MN/m ² (psia)
1 2 3	39.4(15.5) 39.4(15.5) 39.4(15.5)	4.14 (600)	2.25 to 2.92	9 13 93 (cracked between 42-71)	7.3 (16)	16.20 (2350)	12.07 (1750)
4	29.2(11.5)	8.27 (1200)	1.93 to 2.98	26	11 (25)	24.13 (3500)	17.93 (2600)
4 5	29.2(11.5) 29.2(11.5)	13.79 (2000)	1.79 to 2.68	5 1	18 (39)	20.68 (3000)	5.86 (850)

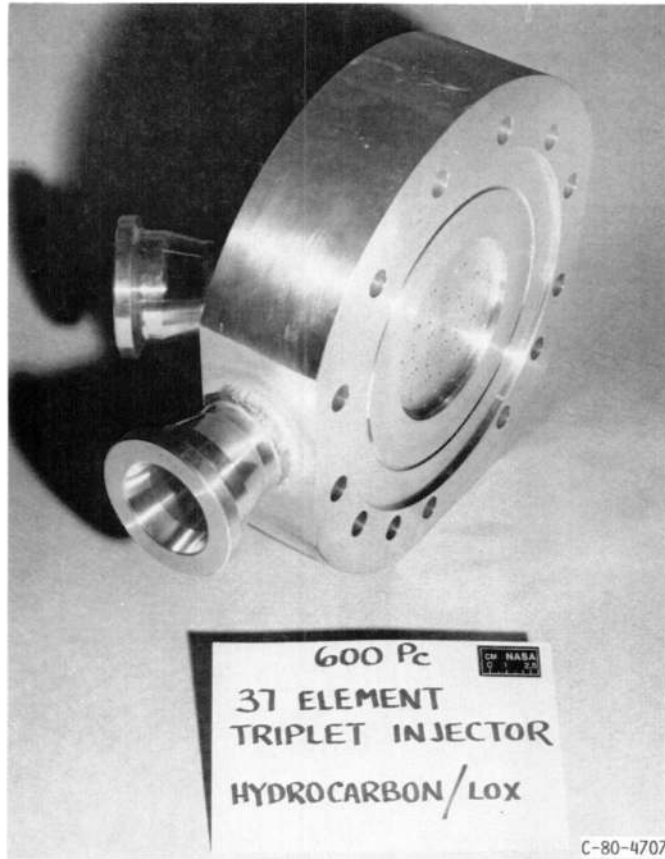

FIGURE 1. - TYPICAL 4.14 MN/m^2 (600 PSIA) CHAMBER PRESSURE INJECTOR.

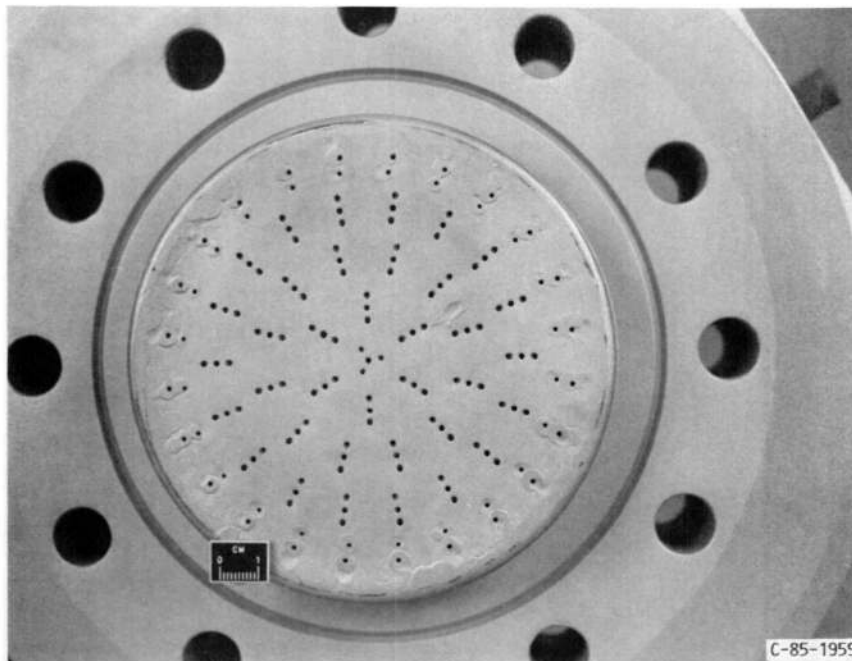

FIGURE 2. - TYPICAL 8.27 MN/m^2 (1200 PSIA) CHAMBER PRESSURE INJECTOR.

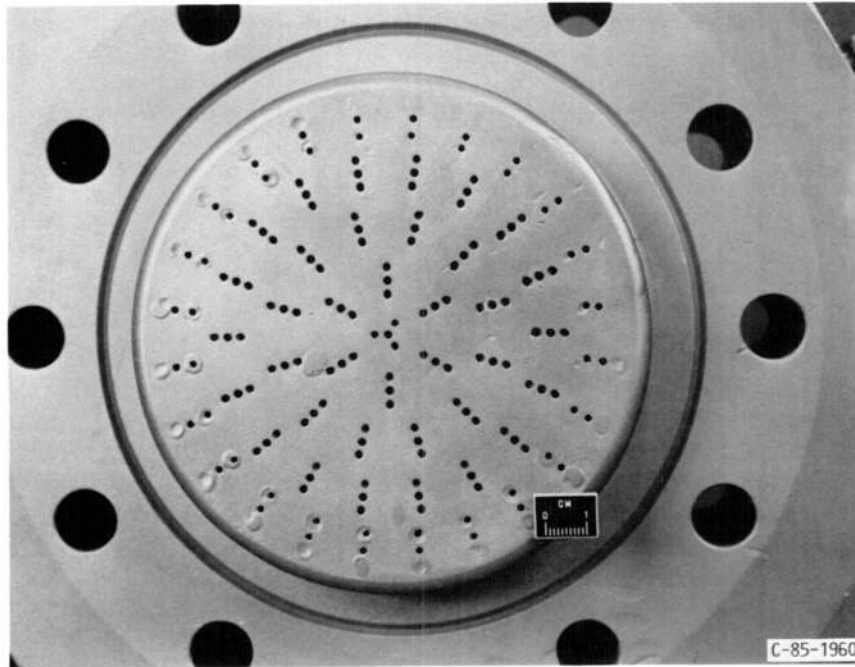

FIGURE 3. - TYPICAL 13.79 MN/m^2 (2000 PSIA) CHAMBER PRESSURE INJECTOR.

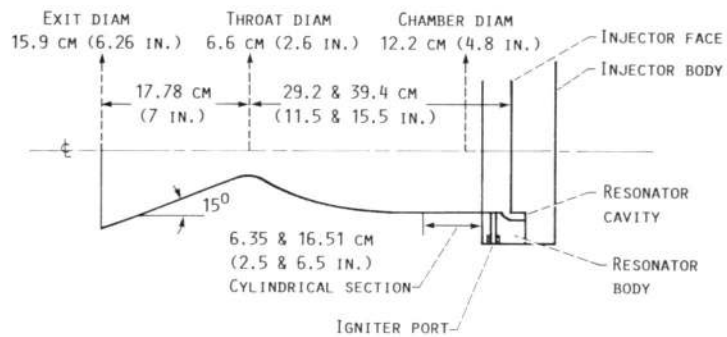

FIGURE 4. - THRUST CHAMBER DIMENSIONS.

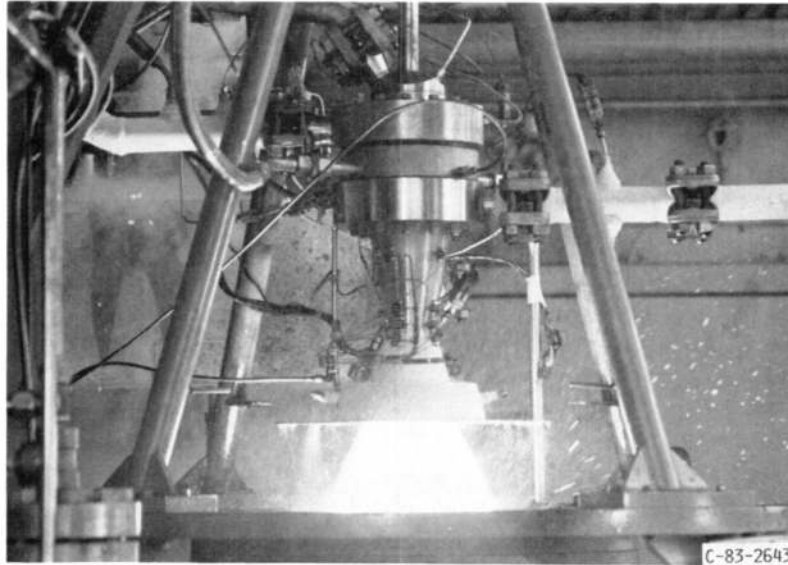

FIGURE 5.- LOX COOLED CHAMBER FIRING LOX/RP-1 PROPELLANTS AT 8.27 MN/m^2 (1200 PSIA) CHAMBER PRESSURE.

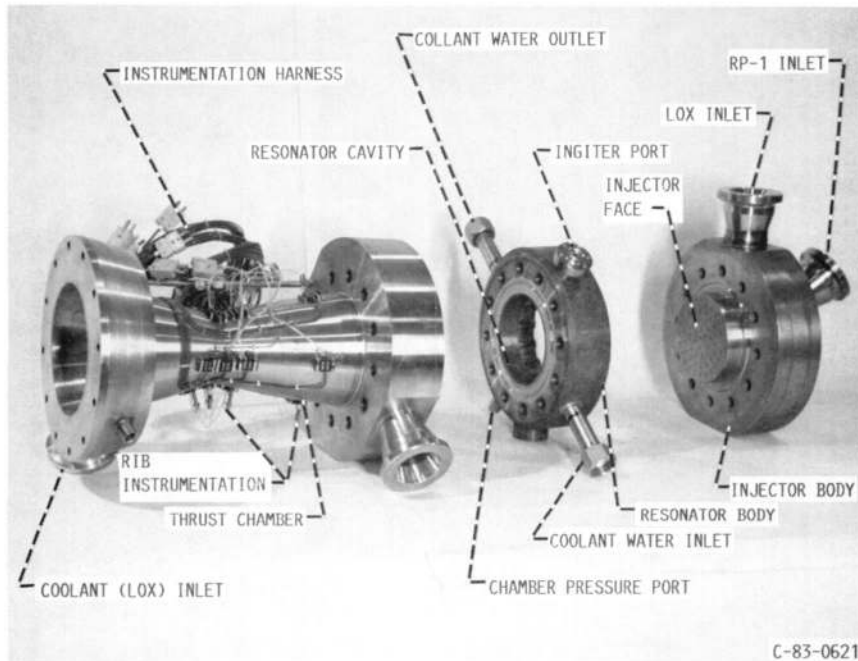

FIGURE 6.- THRUST CHAMBER, RESONATOR, AND INJECTOR.

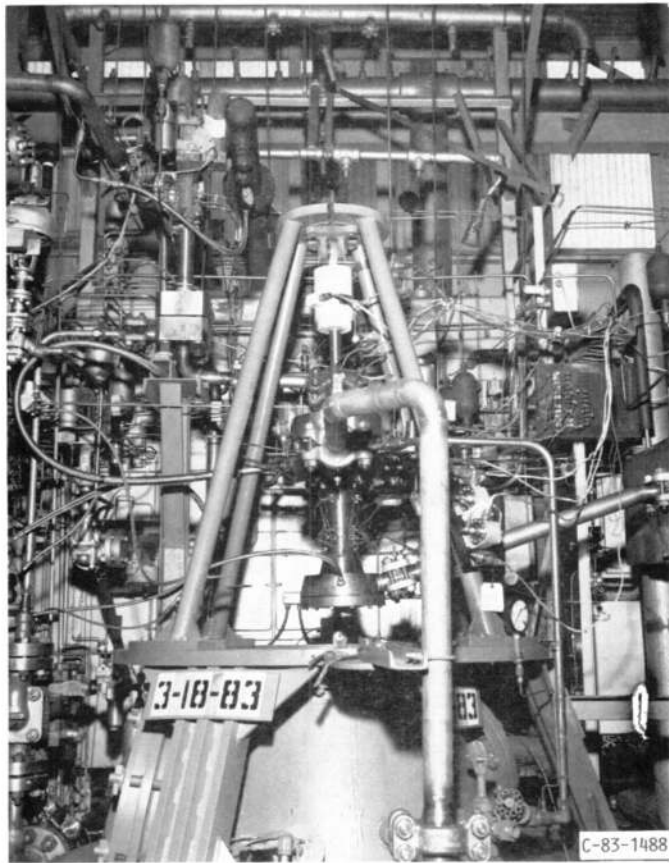

FIGURE 7. - THRUST CHAMBER MOUNTED IN THE TEST FACILITY.

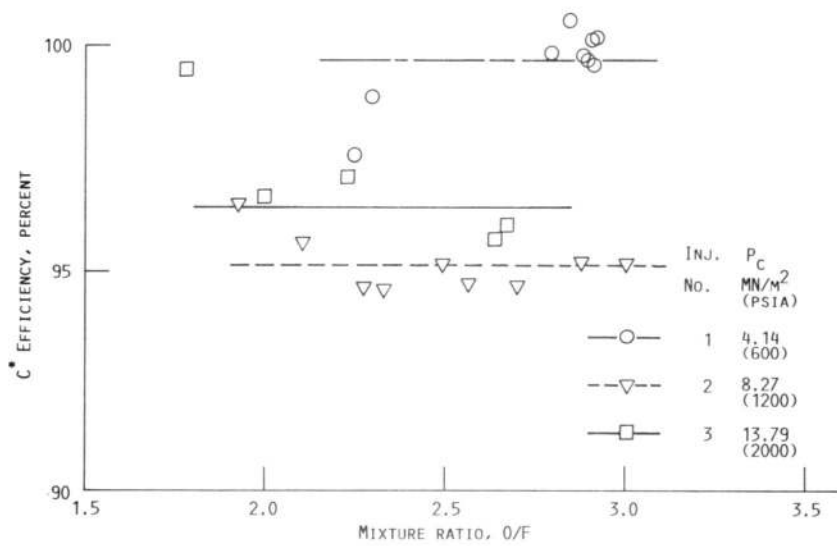
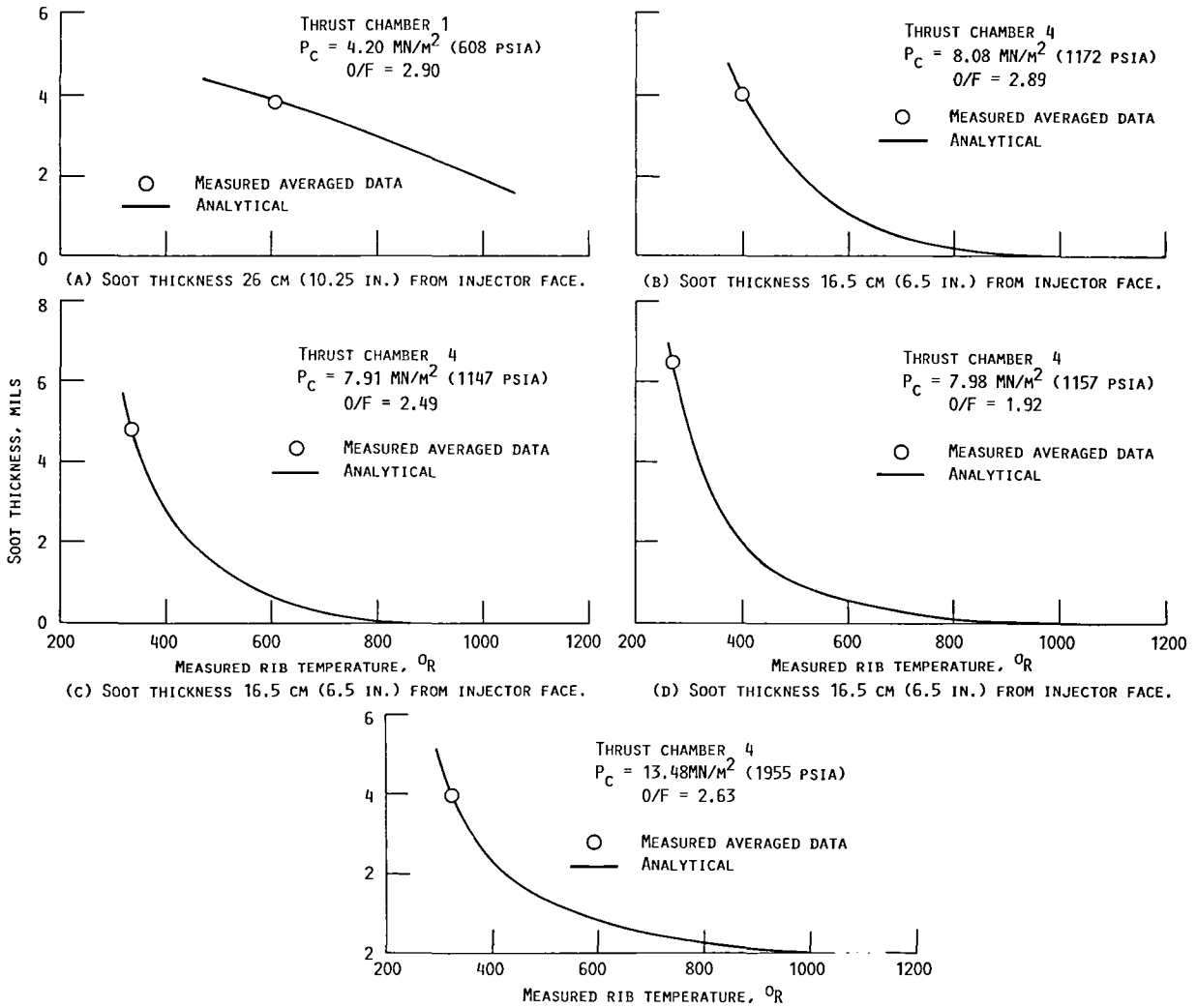

FIGURE 8.- INJECTOR PERFORMANCE.



(E) SOOT THICKNESS 16.5 CM (6.5 IN.) FROM INJECTOR FACE.
 FIGURE 9.- SOOT THICKNESS DISTRIBUTION FOR CYLINDRICAL SECTION.

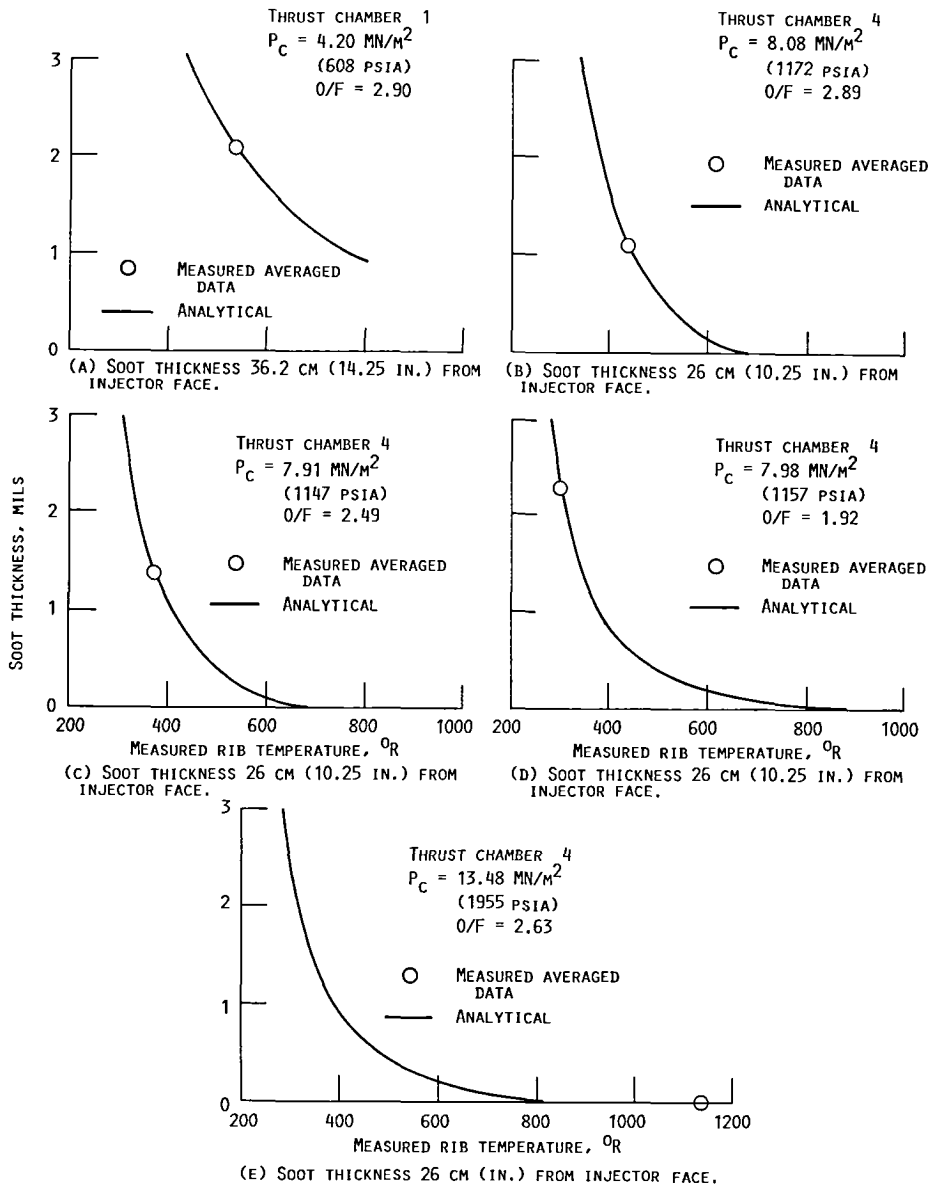

FIGURE 10.- SOOT THICKNESS DISTRIBUTION IN CONVERGING SECTION.

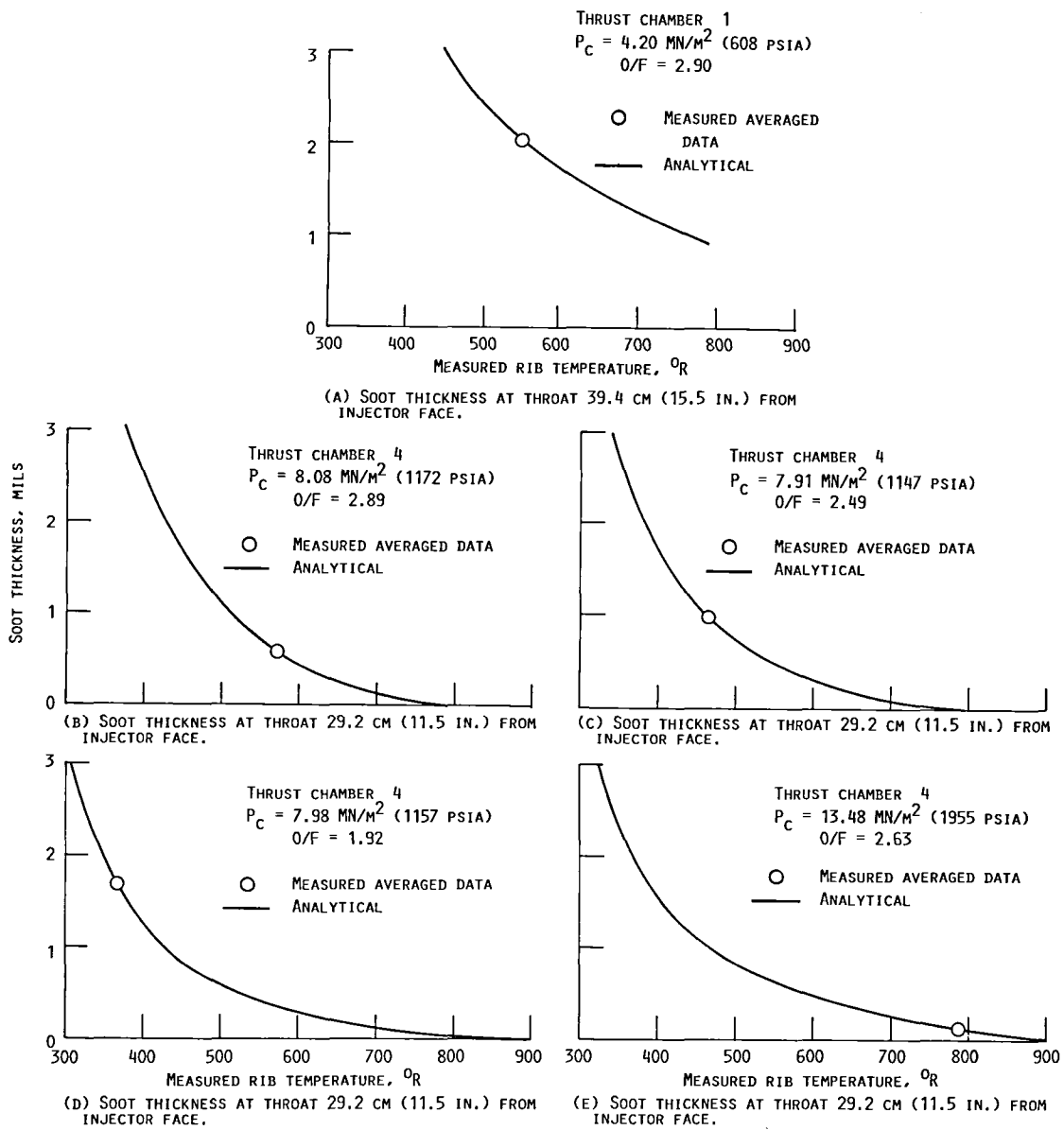
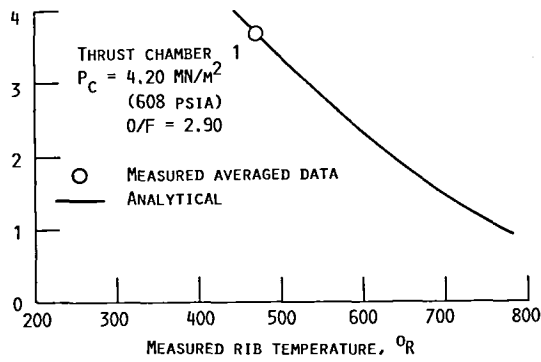
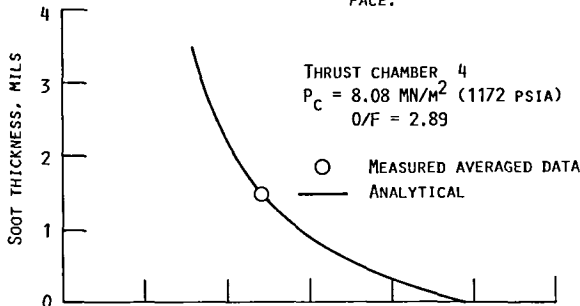

FIGURE 11.- SOOT THICKNESS DISTRIBUTION AT THROAT.



(A) SOOT THICKNESS 41.9 CM (16.5 IN.) FROM INJECTOR FACE.



(B) SOOT THICKNESS 31.8 (12.5 IN.) FROM INJECTOR FACE.

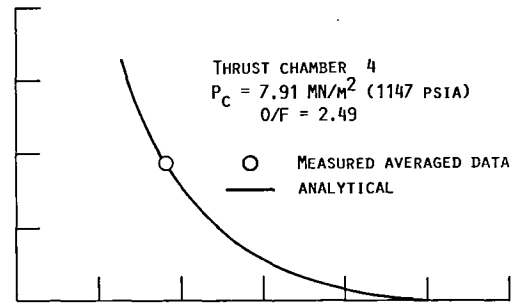

(C) SOOT THICKNESS 31.8 (12.5 IN.) FROM INJECTOR FACE.

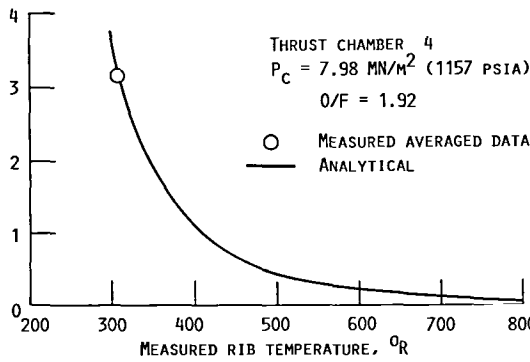

(D) SOOT THICKNESS 31.8 (12.5 IN.) FROM INJECTOR FACE.

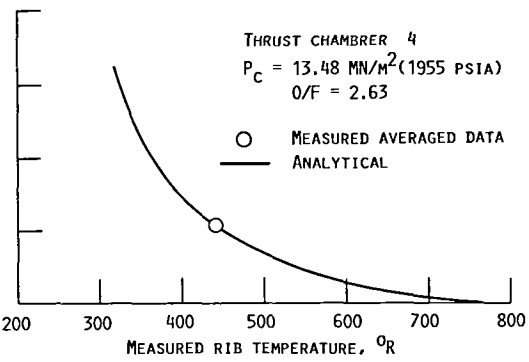

(E) SOOT THICKNESS 31.8 (12.5 IN.) FROM INJECTOR FACE.

FIGURE 12.- SOOT THICKNESS DISTRIBUTION IN DIVERGING SECTION.

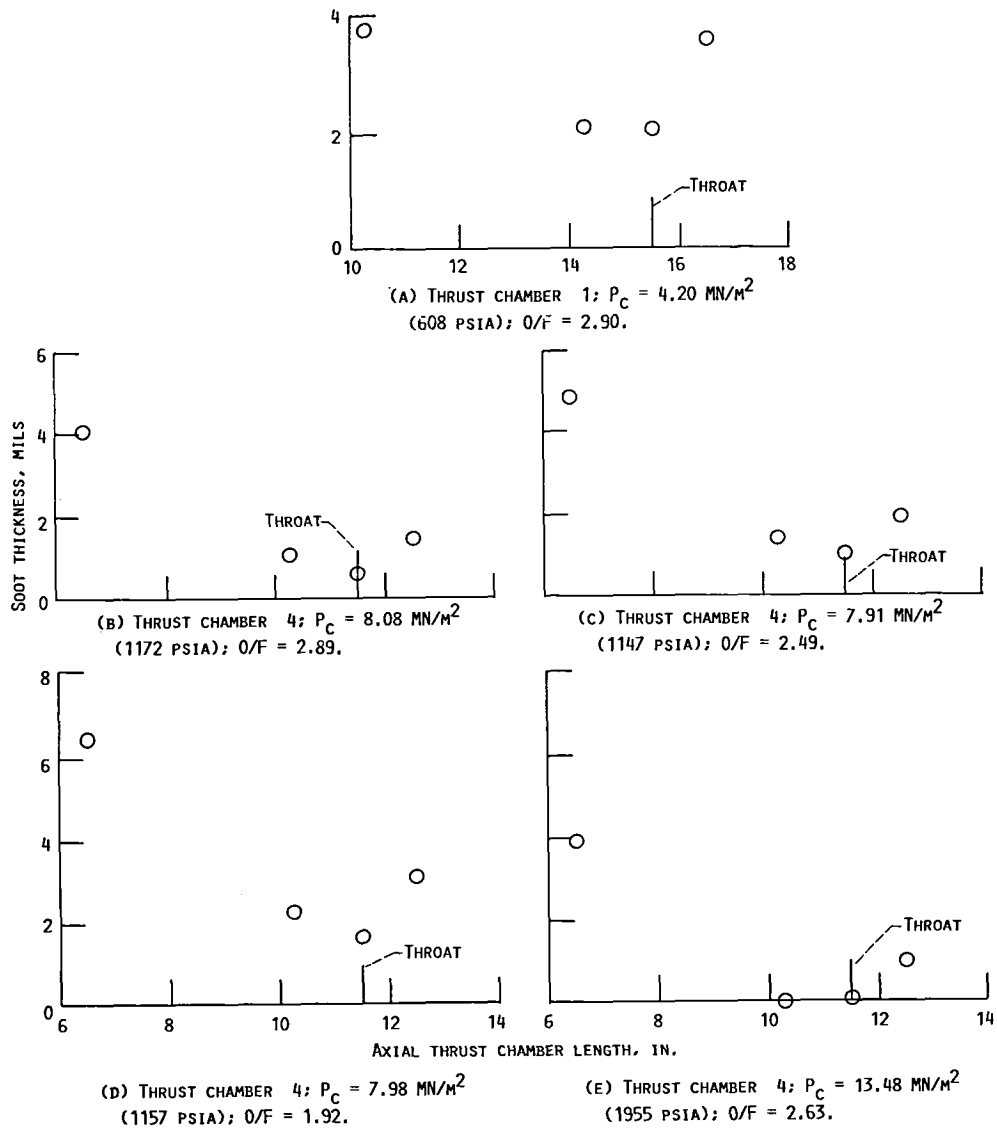

FIGURE 13.- AXIAL SOOT BUILD UP ON HOT GAS WALL SURFACE OF ROCKET THRUST CHAMBER.

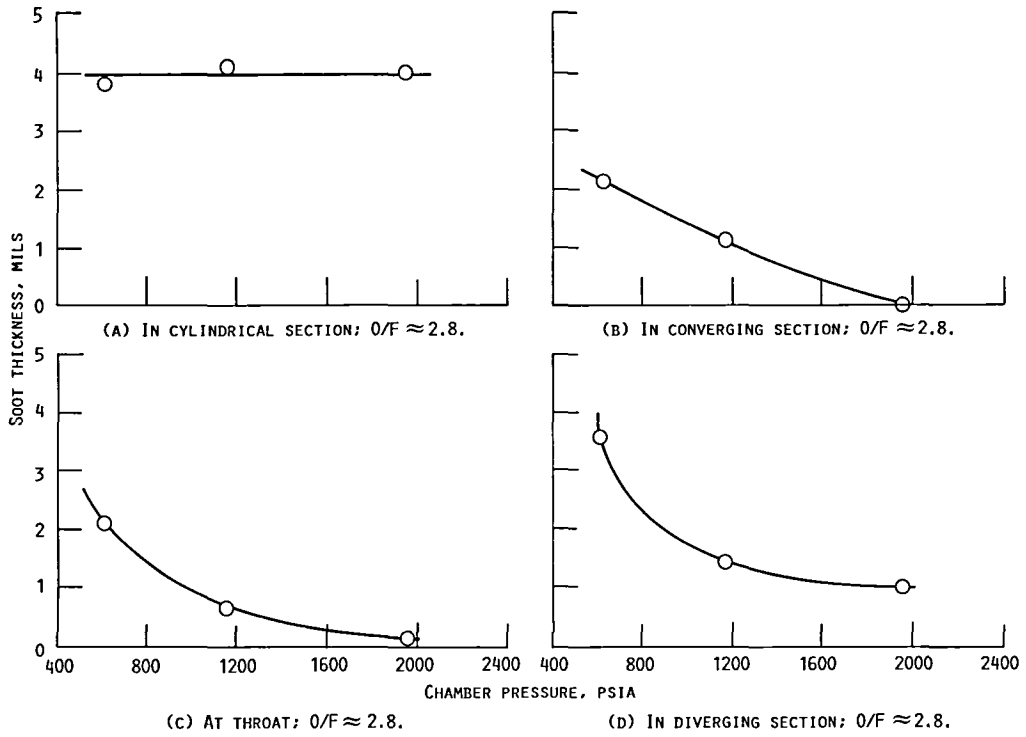

FIGURE 14.- SOOT THICKNESS ON THE HOT GAS WALL VERSUS CHAMBER PRESSURE.

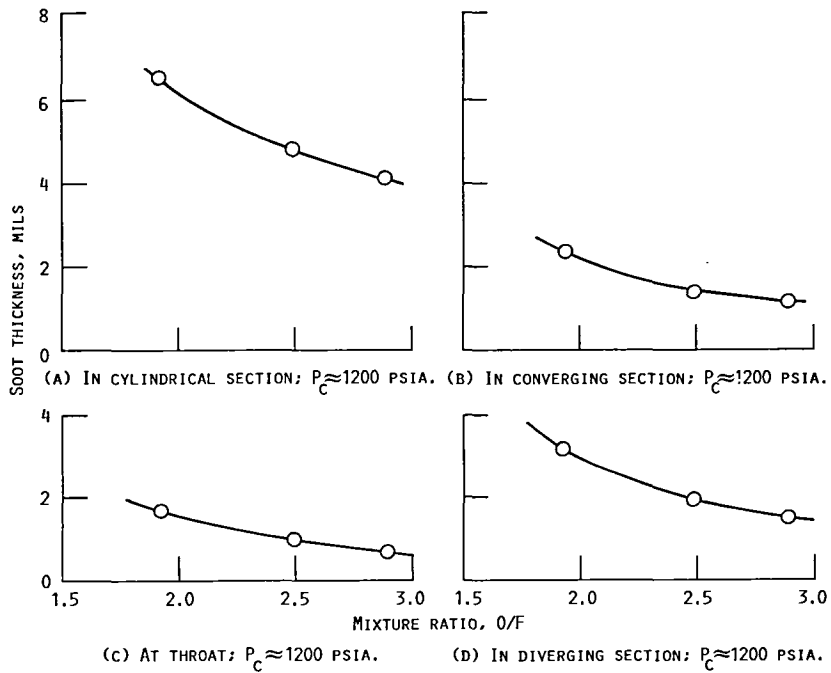
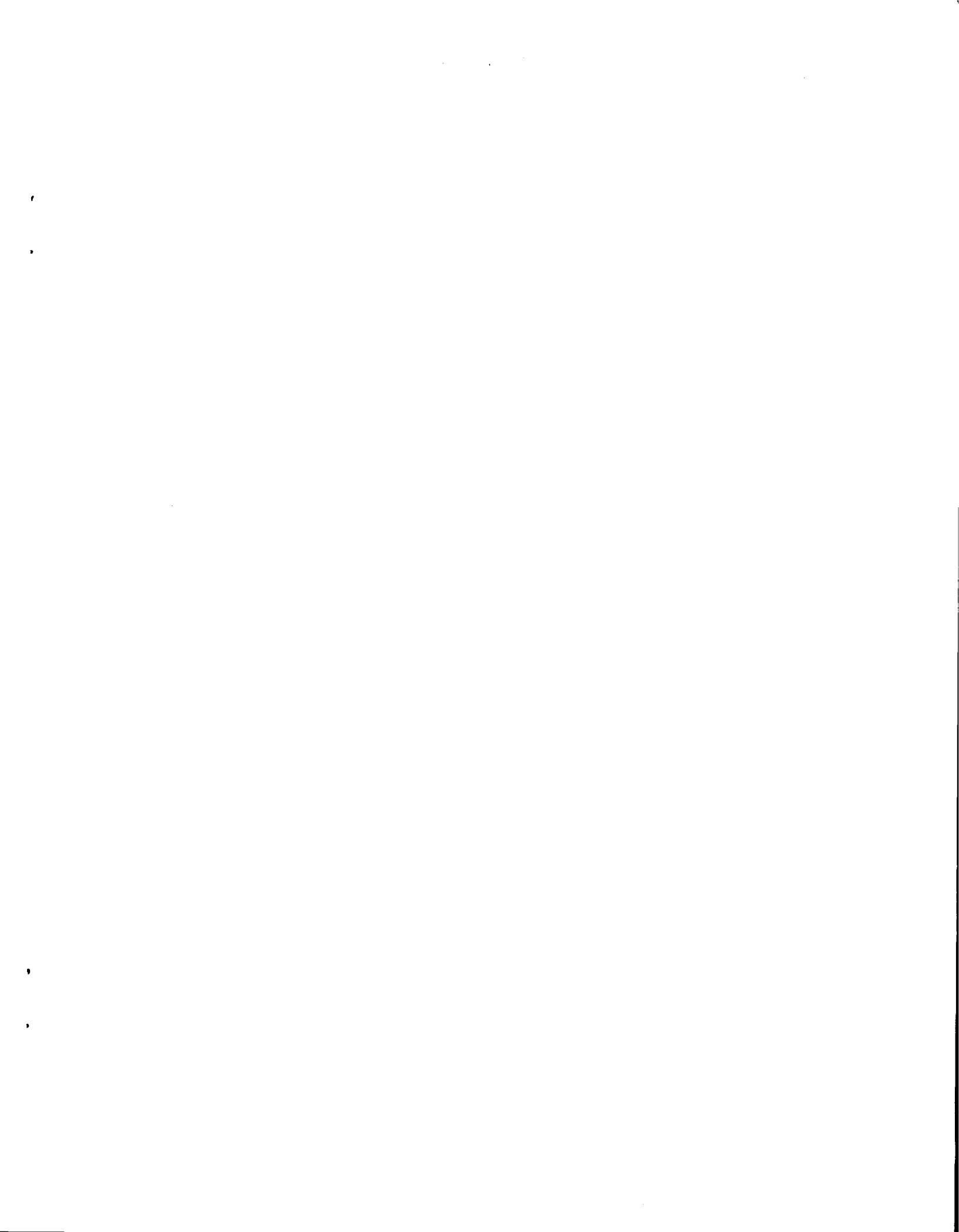

FIGURE 15.- SOOT THICKNESS ON THE HOT GAS WALL VERSUS MIXTURE RATIO.

1. Report No. NASA TM-88805		2. Government Accession No.		3. Recipient's Catalog No.	
4. Title and Subtitle Liquid Oxygen Cooling of High Pressure LOX/Hydrocarbon Rocket Thrust Chambers				5. Report Date August 1986	
				6. Performing Organization Code 553-13-00	
7. Author(s) Harold G. Price and Philip A. Masters				8. Performing Organization Report No. E-3149	
				10. Work Unit No.	
9. Performing Organization Name and Address National Aeronautics and Space Administration Lewis Research Center Cleveland, Ohio 44135				11. Contract or Grant No.	
				13. Type of Report and Period Covered Technical Memorandum	
12. Sponsoring Agency Name and Address National Aeronautics and Space Administration Washington, D.C. 20546				14. Sponsoring Agency Code	
15. Supplementary Notes					
16. Abstract An experimental program using liquid oxygen (LOX) and RP-1 as the propellants and supercritical LOX as the coolant was conducted at 4.14, 8.27, and 13.79 MN/m ² (600, 1200, and 2000 psia) chamber pressure. The objectives of this program were to evaluate the cooling characteristics of LOX with the LOX/RP-1 propellants, the buildup of soot on the hot-gas-side chamber wall and the effect of an internal LOX leak on the structural integrity of the combustor. Five thrust chambers with throat diameters of 6.6 cm (2.6 in.) were tested successfully. The first three were tested at 4.14 MN/m ² (600 psia) chamber pressure over a mixture ratio range of 2.25 to 2.92. One of these three was tested for over 22 cyclic tests after the first through crack from the coolant channel to the combustion zone was observed with no apparent metal burning or distress. The fourth chamber was tested at 8.27 MN/m ² (1200 psia) chamber pressure over a mixture range of 1.93 to 2.98. The fourth and fifth chambers were tested at 13.79 MN/m ² (2000 psia) chamber pressure over a mixture ratio range of 1.79 to 2.68.					
17. Key Words (Suggested by Author(s)) Rocket engine cooling LOX cooling			18. Distribution Statement Unclassified - unlimited STAR Category 20		
19. Security Classif. (of this report) Unclassified		20. Security Classif. (of this page) Unclassified		21. No. of pages	22. Price*



National Aeronautics and
Space Administration

Lewis Research Center
Cleveland, Ohio 44135

Official Business
Penalty for Private Use \$300

SECOND CLASS MAIL

ADDRESS CORRECTION REQUESTED



Postage and Fees Paid
National Aeronautics and
Space Administration
NASA-451

NASA
