

Lawrence Berkeley National Laboratory

Recent Work

Title

Localization of Quenches and Mechanical Disturbances in the Mu2e Transport Solenoid Prototype Using Acoustic Emission Technique

Permalink

<https://escholarship.org/uc/item/0gj2449n>

Journal

IEEE Transactions on Applied Superconductivity, 26(4)

ISSN

1051-8223

Authors

Marchevsky, M
Ambrosio, G
Lamm, M
[et al.](#)

Publication Date

2016-06-01

DOI

10.1109/tasc.2016.2530039

Peer reviewed

Localization of Quenches and Mechanical Disturbances in the Mu2e Transport Solenoid Prototype Using Acoustic Emission Technique

M. Marchevsky, G. Ambrosio, M. Lamm, M. A. Tartaglia, and M. L. Lopes

Abstract—Acoustic emission (AE) detection is a noninvasive technique allowing the localization of the mechanical events and quenches in superconducting magnets. Application of the AE technique is especially advantageous in situations where magnet integrity can be jeopardized by the use of voltage taps or inductive pickup coils. As the prototype module of the transport solenoid (TS) for the Mu2e experiment at Fermilab represents such a special case, we have developed a dedicated six-channel AE detection system and accompanying software aimed at localizing mechanical events during the coil cold testing. The AE sensors based on transversely polarized piezoceramic washers combined with cryogenic preamplifiers were mounted at the outer surface of the solenoid aluminum shell, with a 60° angular step around the circumference. Acoustic signals were simultaneously acquired at a rate of 500 kS/s, prefiltered and sorted based on their arrival time. Next, based on the arrival timing, angular and axial coordinates of the AE sources within the magnet structure were calculated. We present AE measurement results obtained during cooldown, spot heater firing, and spontaneous quenching of the Mu2e TS module prototype and discuss their relevance for mechanical stability assessment and quench localization.

Index Terms—Acoustic emission, acoustic sensors, superconducting magnets.

I. INTRODUCTION

LOCALIZING quenches in superconducting magnets is essential for understanding magnet performance limitations and providing feedback to the magnet designers. Normally, this task is accomplished using voltage taps placed in the windings to monitor the subsequent sections of the magnet. While this technique is straightforward for determining the quenching cable segment, an accurate localization of a hot spot with this technique normally requires introduction of a larger number of taps into windings, which is invasive and often impractical. This is especially true for magnets built in a production environment for permanent installation in a complex system, of which the

Mu2e transport solenoid (TS) is an example. A primary purpose of the TS is to guide muons from the production solenoid to the detector solenoid of the Mu2e experiment [1]. The TS will be constructed of 27 individual modules, each having two superconducting solenoid coils; the modules will be joined axially thus forming a continuous transport line for the muon particles [2]. To ensure consistent operation of this line, it is critical to understand possible quench scenarios in TS solenoids and determine the quench locations [3]. However, the TS module coil windings are fully enclosed within the aluminum shell and do not allow for external access or voltage tap installation—a situation also common to other large solenoid magnet systems [4]. Also, magnetic quench antennas that are common for accelerator magnets [5] cannot be used here either, as any transient magnetic disturbance due to a quench development will be effectively shielded by the thick aluminum shell enclosing the windings. Therefore, the acoustic emission (AE) technique was chosen as a simple, non-invasive way of quench localization. A working principle of this technique is based upon time-domain analysis of AE signals associated with the quench development [6]. These emissions are primarily generated by local mechanical disturbances in the magnet, showing up as characteristic “spikes” followed by a gradual decay in amplitude. A disturbance that dissipates energy in excess of the minimum quench energy initiates quenching, in which case AE being a signature of the mechanical quench precursor is generated just prior or simultaneously to the onset of magnet resistance. Alternatively, quenching can be induced by other mechanism, such as, for example, local conductor degradation or external heating. In those cases AE is still generated due to a rapid thermal expansion causing local pressure build-up and micro-cracking of epoxy resin around the developing hotspot. However, it happens only after quenching has already started, and hot spot development is in progress. AE generally lags behind the onset of magnet resistance in this case, its amplitude is generally weaker, and it rises gradually without the characteristic initial “spike.” Possible links between AE and quenching in superconducting magnets are discussed in [7]. In order to localize a quench, a dedicated AE detection system has been designed, built, and installed on the Mu2e TS prototype. System operation has been tested in various modes, including localization of mechanical disturbances during cooldown, firing of spot heaters, and spontaneous thermally-induced quenching of the magnet.

Manuscript received October 20, 2015; accepted February 3, 2016. Date of publication March 12, 2016; date of current version March 24, 2016. This work was supported in part by FRA under DOE Contract DE-AC02-07CH11359.

M. Marchevsky is with the Lawrence Berkeley National Laboratory, Berkeley, CA 94720 USA (e-mail: mmartchevskii@lbl.gov).

G. Ambrosio, M. Lamm, M. A. Tartaglia, and M. Lopes are with the Fermi National Accelerator Laboratory, Batavia, IL 80510 USA.

Color versions of one or more of the figures in this paper are available online at <http://ieeexplore.ieee.org>.

Digital Object Identifier 10.1109/TASC.2016.2530039

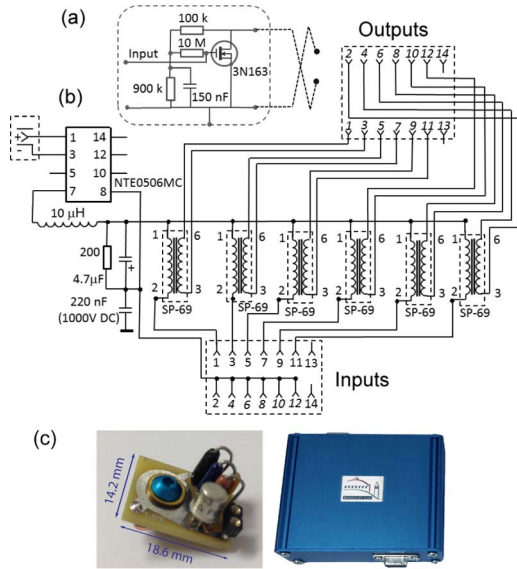

Fig. 1. (a) Electrical schematic of the cryogenic preamplifier of the AE piezosensor. (b) Electrical schematics of the coupling box. (c) View of the assembled AE sensor and the coupling box.

II. AE HARDWARE, SOFTWARE, AND CALIBRATION

A. AE Sensor Hardware and Installation

The Mu2e AE detection and acquisition hardware includes six amplified piezo-sensors, a coupling interface box, and a fast synchronous data acquisition system (DAQ). Transversely-polarized piezo-transducers (PZT)—ceramics ring elements of 10 mm in diameter and 1 mm in thickness are used as sensing elements. PZT elements are interfaced to MOSFET-based cryogenic preamplifiers with a bandwidth of 100 Hz–300 kHz and operational temperature range of 300–1.9 K [8]. Use of MOSFETs allows converting a high piezo-element impedance down to ~ 1 k Ω , thus significantly improving signal-to-noise ratio, and allowing for regular “twisted pair” cables being used instead of coax for instrumenting the sensors to the cryostat header and then further on to the coupling box. Schematics of the AE sensor and coupling box electronics are shown in Fig. 1(a) and (b). The system comprising six AE sensors (plus one spare) and the coupling box ready for installation on the magnet is shown in Fig. 1(c). The sensors were bolted directly to the outer surface of the TS aluminum shell, with a uniform 60 deg. angular step around the coil circumference. Axially, the sensors were displaced sequentially up and down from the median line. Sensor coordinates (θ_i, y_i) relative to a single point reference were measured directly on the magnet after installation, and later used for triangulating the AE source locations.

B. Data Acquisition

Given typical sound velocity in metal structures of 2–5 km/s, the spatial accuracy of determining the AE source is defined by the sensor bandwidth of ~ 300 kHz, yielding ± 2 cm of spatial resolution in the ideal case of a uniform metal cylinder representing the magnet. In practice, since magnet structure

is heterogeneous, sound velocity variation along the acoustic wave path leads to a reduced localization accuracy. Recent AE experiments conducted on superconducting accelerator magnets [9] allowed matching of acoustically determined quench location to those identified with the voltage taps, and the localization accuracy was estimated as $\sim \pm 5$ –10 cm. The DAQ system for AE studies should be adequately fast to not limit the spatial resolution of the technique. For the Mu2e TS module prototype experiments a NI PXI-8360 simultaneous DAQ card operating at 500 kHz was used. The data were acquired in a triggered mode, having a window of 0.5–2 s centered on the trigger event. The acquisition triggering was either internal set by any of the six sensor signals rising above the preset threshold level, or external from the main trigger line of the quench detection system. In addition to AE sensor signals, the magnet current (analog) was simultaneously acquired.

C. Software

Custom software was written in LabVIEW to process the AE signals. For analyzing a particular acoustic “event,” the following sequence was implemented:

- 1) High-pass filtering at 5 kHz (to eliminate vibrations due to structural mechanical resonances of the solenoid, showing peaks at 2210–2380 Hz and at 1550 Hz), followed by rectification of the signals.
- 2) Measurement of relative timing of level threshold crossing $\Delta t_{S_a S_i}$ for every sensor (assuming t_{S_a} is the minimal arrival time measured by the sensor S_a closest to the AE source). The level threshold was typically chosen in the range at 5σ of the noise amplitude within the acquisition window preceding the event.
- 3) Determination of the event source azimuthal angle, assuming uniform angular sound velocity $\theta = c/r$, (where c is the sound velocity, and r is the mean solenoid radius), and ignoring axial displacement of the sensors. The angular sound velocity is determined as $\theta = (\pi/3)\Delta t_{S_c S_b}$, such that S_a , S_b , and S_c are three azimuthally consecutive sensors at the coil circumference.
- 4) Determination of the event location in 2D, using a triangulation procedure. The outer cylindrical surface of the TS module is projected on a plane ($x' = r\theta$, $y' = y$), the three sensors closest to the AE source are selected based on signal arrival timing, and then a set of quadratic equations for the event coordinate (x_0, y_0) in the form:

$$(x_0 - x_1)^2 + (y_0 - y_3)^2 = R_1^2$$

$$(x_0 - x_3)^2 + (y_0 - y_3)^2 = R_2^2$$

$$(x_0 - x_3)^2 + (y_0 - y_3)^2 = R_3^2$$

$$|R_1 - R_2| = c|t_2 - t_1|; |R_1 - R_3| = c|t_3 - t_1|$$

is solved for (x_0, y_0) assuming uniform sound velocity c in the structure found with the angular calibration procedure. Finally, the azimuthal angle found in (3) and the 2D coordinate found in (4) are projected back onto a 3D CAD model of the TS module, and the result is displayed by superimposing the AE source location to the model drawing.

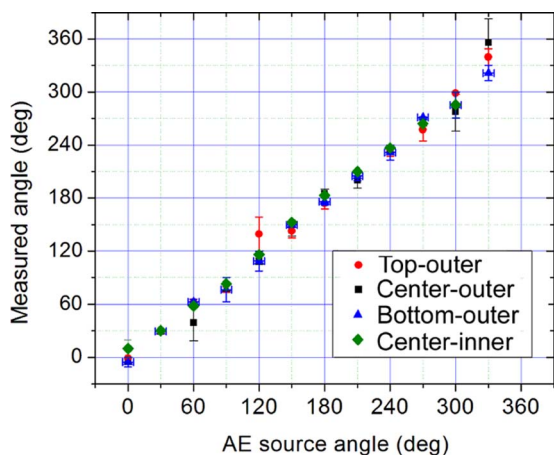

Fig. 2. Verification of testing results for the series of “knocks” made along the inner and outer circumferences of TS prototype: azimuthal angles determined with the AE system are plotted against the actual ones of the “knocking” locations. Horizontal bars represent typical inaccuracy of the actual angle ($\pm 5^\circ$), whereas vertical bars are computed as plus and minus the differences between expected and measured values.

D. Calibration

For calibration of the AE signal threshold level and adjusting the DAQ settings, the TS module prototype was suspended from a crane on ropes to mechanically isolate it from supports. Then the aluminum shell surfaces were knocked with a small hammer along the inner and outer circumference of each coil at multiple locations separated angularly by $30 (\pm 5)$ deg.; for each “knock” AE signals were recorded and angular locations calculated based on signal arrival timing. Result of such tests are shown in Fig. 2. The sensor S1 azimuthal coordinate is taken as zero. While occasional discrepancies are observed due to the intrinsic uncertainty of the manual excitation technique, overall a very good agreement between the actual and measured AE source azimuthal angle is found.

III. EXPERIMENTAL

A. Cooldown

The TS solenoid is wrapped in 40 layers of multi-layer insulation and cooled in vacuum with liquid helium flowing through the two pipeline encircling the aluminum shell of the solenoid [10]. The cooldown rate was mostly stable at ~ 4 K/h. Two examples of AE signals generated by the mechanical events during cooldown are shown in Fig. 3(a), and the polar histogram plot summarizing the intensity distribution of AE events over the entire cooldown is shown in Fig. 3(b). Only the AE events resulting in a detected voltage of above 0.2 V by all six sensors (1132 events in total) were counted. Clearly, the azimuthal distribution of the AE sources is anisotropic, and shows prominent peaks at 95, 190, 246, and 276 deg. The latter two peaks are pointing azimuthally toward the injection and venting point of the liquid helium line, and thus may be associated with high thermal gradients in those areas causing intermittent mechanical disturbances. The origin of the other two peaks is presently unclear, but they may be linked to the locations of the structural support.

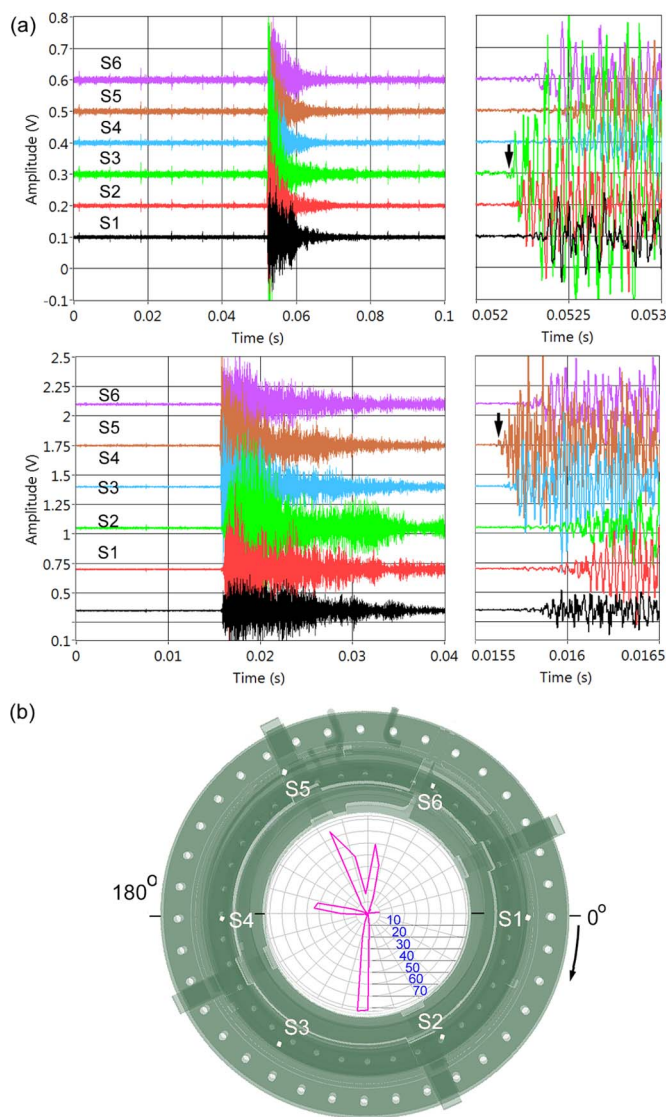

Fig. 3. (a) Examples of AE signals generated by mechanical events during cooldown (top plots) and their relative timing around the arrival time. The first arriving signal is marked with an arrow. (b) Polar histogram plot of the AE source distribution acquired during magnet cooldown to 4.5 K, matched to the coil geometry.

B. Spot Heater Firing

The TS prototype module has four spot heaters installed on each coil in their inner bore at 90° azimuthal increments. Spot heaters were fired with a 1.5 s dc current pulse during the cold test to induce a quench, and at the same time an attempt was made to use them as location calibration sources for our AE system. AE signals due to spot heater firing are only of ~ 20 mV in amplitude, which is about twice the background noise. Moreover, the long interval (typically 300–1000 ms) required for spot heaters to initiate a quench had to be properly accounted for when acquiring AE data. Only one of the three single heater firing attempts generated AE of sufficient amplitude for azimuthal localization of the source. The result is shown in Fig. 4. A heater in the “upper” coil [10] was fired, and the quench in this coil followed in ~ 320 ms. The fairly large discrepancy of ~ 30 deg. between measured and actual azimuthal locations can

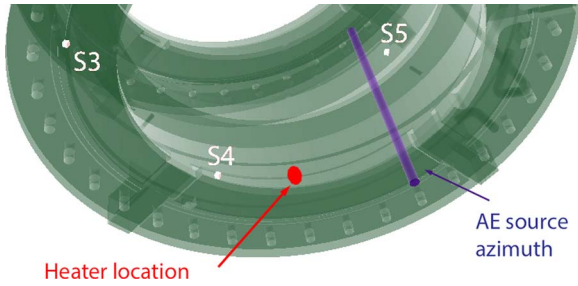

Fig. 4. Azimuthal location of the AE source due to a spot heater firing, superimposed on a 3-D magnet projection. The difference between the experimentally determined azimuth and the actual heater azimuth is $\sim 30^\circ$.

be attributed to the low signal-to-noise ratio of this AE event introducing error in the timing. Next, another heater located at 90 deg. clockwise (per Fig. 4 drawing) in the “lower” coil was fired. Compared to the previous heater experiment, it generated AE of lower amplitude at all six sensors, of which the largest AE signal corresponded to sensor S3 closest to the heater. Unambiguous arrival timing of the AE signals in this case was not possible due to the low amplitude of the signals.

C. Spontaneous Quench

No mechanically generated quenches were observed during cold testing of the TS module prototype at the nominal (4.5 K) operating temperature. However, during temperature margin studies a spontaneous quench was initiated by gradually increasing coil temperature (up to 8.0 K) while holding the current at the nominal (1730 A). The results are shown in Fig. 5. The quench detection system (QDS) was set up to monitor total magnet voltage and imbalance voltage between the coil halves. It would trigger current extraction upon detecting voltages above 0.5 V threshold for 1 s of validation time. A burst of AE was detected by all six sensors, starting ~ 25 ms after the arrival of QDS trigger, and simultaneously with an onset of current decay in the coil. The arrival times t_1 , t_2 , and t_3 of the three earliest arriving signals were detected using the same amplitude threshold [Fig. 5(b)], and the azimuthal position as well as the triangulated axial position were found [Fig. 5(c)]. The AE source appeared to be in the vicinity of sensor S4, at ~ 11 deg. azimuthal angle toward S5. The axial location appeared to be near the middle of the magnet, matching the interface between the central cooling channel and the lower coil.

IV. CONCLUSION

An AE detection and localization system for the prototype Mu2e transport solenoid has been built, installed, and tested. Room temperature experiments showed reliable azimuthal localization of mechanical disturbances to the magnet shell surfaces. During cooldown, the angular distribution of mechanical events in the magnet caused by thermal stresses has been measured. AE location associated with the spontaneous magnet quench has been successfully localized. In the future, the AE quench localization system may be used for monitoring mechanical disturbances, and providing continuous feedback on

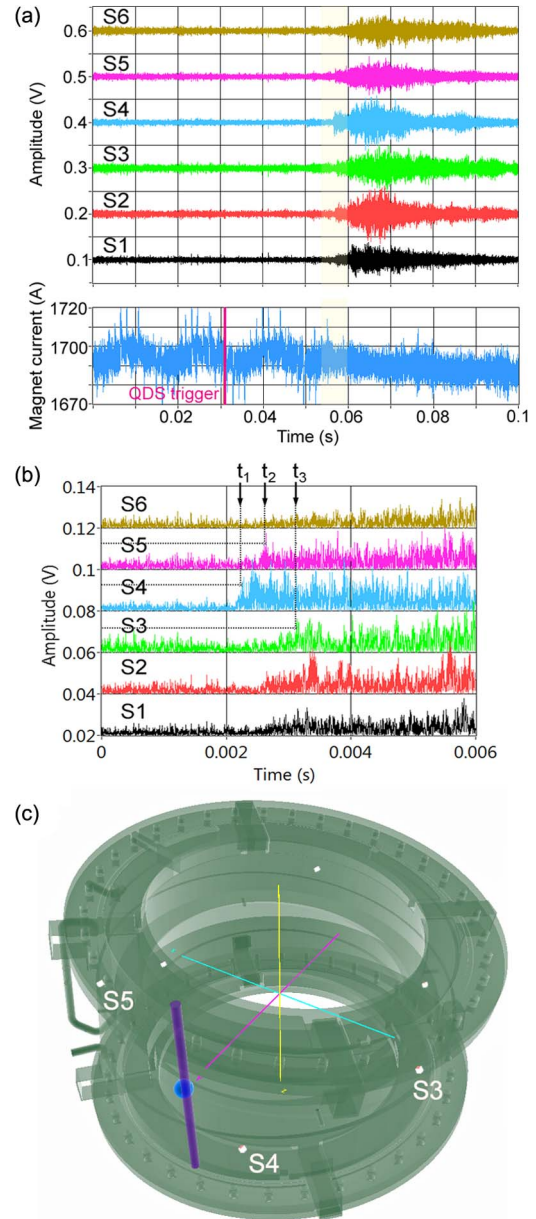

Fig. 5. AE source localization during a spontaneous quench. (a) (Top) High-pass-filtered AE signals acquired by the sensors (S1–S6) showing a burst of AE due to a developing quench. Signal traces have been progressively offset by 0.1 V for clarity. (Bottom) Time dependence of the magnet current with a superimposed rising edge of the quench detection trigger signal. (b) Zoomed-in rectified AE signals showing the onset of the quench. Signal traces have been progressively offset by 0.02 V for clarity. Arrival times were determined as threshold crossings of the same dc level (~ 12 mV) for all channels. The earliest arriving signal is at sensor S4, followed by sensors S5 and S3. (c) (Line) Azimuthal and (dot) 3-D triangulated locations of the AE source shown on the magnet model.

the mechanical integrity of the TS assembly during operation. Should a spontaneous quench occur, such a system can quickly provide valuable information about quench location that may be inaccessible using other techniques.

ACKNOWLEDGMENT

The authors are thankful to all members of the Mu2e team at Fermilab, and especially C. Sylvester, L. Kokoska, D. Orris

and D. Walbridge for their hospitality and technical assistance in installation and interfacing the AE system. The help of T. Lipton and M. Turqueti of LBNL with setup and transportation of the DAQ system is gratefully acknowledged. We are grateful to F. Porter for careful proofreading of the manuscript.

REFERENCES

- [1] D. Brown, "Mu2e: A muon to electron conversion experiment at Fermilab," *Nucl. Phys. B, Proc. Suppl.*, vol. 248–250, pp. 41–46, 2014.
- [2] "Mu2e conceptual design report," Mu2e Collab., Washington, DC, USA, arXiv:1211.7019. [Online]. Available: <http://arxiv.org/abs/1211.7019>.
- [3] G. Ambrosio *et al.*, "Challenges and design of the transport solenoid for the Mu2e experiment," *IEEE Trans. Appl. Supercond.*, vol. 24, no. 3, Jun. 2014, Art. no. 4101405.
- [4] Q. Wang *et al.*, "A superconducting magnet system for whole-body metabolism imaging," *IEEE Trans. Appl. Supercond.*, vol. 22, no. 3, Jun. 2012, Art. no. 4400905.
- [5] T. Ogitsu *et al.*, "Quench antenna for superconducting particle accelerator magnets," *IEEE Trans. Magn.*, vol. 30, no. 4, pp. 2273–2276, Jul. 1994.
- [6] O. Tsukamoto and Y. Iwasa, "Acoustic emission triangulation of disturbances and quenches in a superconductor and a superconducting magnet," *Appl. Phys. Lett.*, vol. 40, pp. 538–540, 1982.
- [7] O. Tsukamoto and Y. Iwasa, "Sources of acoustic emission in superconducting magnets," *J. Appl. Phys.*, vol. 54, pp. 997–1007, 1983.
- [8] M. Marchevsky, G. Sabbi, H. Bajas, and S. Gourlay, "Acoustic emission during quench training of superconducting accelerator magnets," *Cryogenics*, vol. 69, pp 50–57, 2015.
- [9] M. Marchevsky *et al.*, "Test of the high-field Nb3Sn dipole magnet HD3b," *IEEE Trans. Appl. Supercond.*, vol. 24, no. 3, 2014, Art. no. 4002106.
- [10] M. L. Lopes *et al.*, "Mu2e transport solenoid prototype tests results," *IEEE Trans. Appl. Supercond.*, vol. 26, no. 4, Jun. 2016, Art. no. 4101105.