

5-29-2017

# Low Cost Air Quality Monitoring: Exploration and Development of Prototype

Mimi Shang  
*Portland State University*

Follow this and additional works at: <https://pdxscholar.library.pdx.edu/honorsthesis>

Let us know how access to this document benefits you.

---

## Recommended Citation

Shang, Mimi, "Low Cost Air Quality Monitoring: Exploration and Development of Prototype" (2017).  
*University Honors Theses*. Paper 479.  
<https://doi.org/10.15760/honors.478>

This Thesis is brought to you for free and open access. It has been accepted for inclusion in University Honors Theses by an authorized administrator of PDXScholar. Please contact us if we can make this document more accessible: [pdxscholar@pdx.edu](mailto:pdxscholar@pdx.edu).



# **Low Cost Air Quality Monitoring**

*Exploration and Development of Prototype*

*Mimi Shang*

An undergraduate honors thesis submitted in partial fulfillment of the requirements for the degree of Bachelor of Science in University Honors and Mechanical Engineering.

Portland State University June 2017

Thesis Advisor: Olyssa Starry

## **ABSTRACT**

The high cost of environmental monitoring is often a barrier to data collection for researchers as well as citizen scientists. As sensor technology becomes more accessible, the development of low cost data collection systems is becoming more useful. This thesis explored the utility of low cost air monitoring. A low cost sensor platform air monitoring system, with a total cost of less than \$200, was designed and implemented. A number of sensors were considered and evaluated, and a final sensor platform was assembled, programmed, and calibrated to measure Ozone (O<sub>3</sub>), Carbon Monoxide (CO), Carbon Dioxide (CO<sub>2</sub>) and particulate matter (PM 2.5) sensors. Data from the resulting system was collected and compared with data from documented high accuracy instrumentation to assess the viability of using these low cost sensors for ambient air quality monitoring. The accuracy of these sensors varied greatly, but some sensors were accurate enough to gather quality lab data for a fraction of the cost of industry standard instruments.

## ACKNOWLEDGMENTS

I would like to thank Olyssa Starry for introducing me to this project, mentoring me through this thesis and many other projects, and taking time to work with me on integrating ecology and engineering. I would also like to thank Elliot Gall for giving me access and resources of the Green Building Research laboratory and teaching me about air quality monitoring and sensing. Additionally, I would like to acknowledge Sam Salin, Pradeep Ramasubramanian, Craig Lardiere, and all the members of the Green Building Research lab who have supported me on this project in big and small ways. I would like to thank the NSF for their generous funding (CBET grant #[1605843](#)) of environmental research, and the Maseeh College of Engineering and Computer Science for providing the education and resources for my success.

## Contents

|  |           |
|--|-----------|
| <b>1 Introduction and Background .....</b>                 | <b>1</b>  |
| <b>2. Methods .....</b>                                    | <b>5</b>  |
| <b>2.1 Sensor Selection .....</b>                          | <b>5</b>  |
| <b>2.2 Sensor Calibration .....</b>                        | <b>6</b>  |
| <b>2.2.1 SHT31-D Temperature and Humidity Sensor .....</b> | <b>6</b>  |
| <b>2.2.2 SM-50 Aeroqual Ozone Sensor .....</b>             | <b>7</b>  |
| <b>2.2.3 MiCS-2614 Ozone Sensor .....</b>                  | <b>8</b>  |
| <b>2.2.4 EC4-500-CO Carbon Monoxide Sensor .....</b>       | <b>11</b> |
| <b>2.2.5 K30 Carbon Dioxide Sensor .....</b>               | <b>11</b> |
| <b>2.2.6 PPD42 Particulate Matter Sensor .....</b>         | <b>12</b> |
| <b>2.3 Data Acquisition .....</b>                          | <b>12</b> |
| <b>2.4 System Assembly .....</b>                           | <b>12</b> |
| <b>3. Results .....</b>                                    | <b>14</b> |
| <b>4. Conclusion .....</b>                                 | <b>15</b> |
| <b>4.1 Future Steps .....</b>                              | <b>15</b> |
| <b>4.2 Implications .....</b>                              | <b>16</b> |
| <b>References .....</b>                                    | <b>16</b> |

## List of Figures

|   |   |    |
|---|---|----|
| 1 | Diagram of Air Quality Egg Sensor Platform (Left) and M-Pod mobile sensor plat-form (right) ..... | 2  |
| 2 | SHT31-D Temperature and humidity sensor by Adafruit .....   | 6  |
| 3 | First Calibration of SM50 Ozone Sensor .....  | 7  |
| 4 | Calibration apparatus for SM50 Ozone sensor .....   | 8  |
| 5 | MiCS-2614 Ozone Sensor by Sensortech .....  | 9  |
| 6 | First Calibration of MiCS-2614 Ozone Sensor.....  | 10 |
| 7 | Verification of Calibration of CO2 Sensor .....   | 11 |
| 8 | Diagram of low cost air quality monitoring platform.....  | 13 |
| 9 | Diagram of low cost air quality monitoring platform.....  | 13 |

## List of Tables

|   |   |    |
|---|---|----|
| 1 | Overview of 2 existing low cost air quality monitoring platforms, the Mimi V1 platform developed in this thesis, and an industry standard air quality management system ..... | 4  |
| 2 | Specifications of Selected Air Quality Monitoring Sensors.....  | 5  |
| 3 | Data collected at Lafayette DEQ station and collocated with industry standard in-instrumentation.....   | 14 |

## **1 Introduction and Background**

In February 2016, a study of moss reflecting air pollution in Portland, Oregon sent the city into a panic. High levels of toxic heavy metals were revealed to be present in both industrial and residential areas (Gatziolis, Jovan, Donovan, Amacher, & Monleon, 2016). This research began in 2013, but was not published publicly until three years later. The public health implications of these results were frightening. Residential areas, some with schools, were being exposed to quantities of toxins far beyond the acceptable amount. The result was public outrage. Residents of these neighborhoods attended city council meetings to protest that they had been unknowingly exposing themselves and their kids to these toxins. Public pressure forced a glass factory to change their manufacturing processes to reduce their emissions, and larger studies of heavy metals in air and soil in Portland are currently underway. This example reflects a larger environmental challenge that many communities, especially urban ones, are facing with respect to air quality. The need for urban air quality monitoring is becoming more pertinent as cities continue to expand (Kumar et al., 2015).

The moss study panic in Portland reflects a larger problem in Science, Technology, Engineering and Mathematics (STEM): Research with huge implications on public health is not accessible to the general public. Compounding this, communities most affected by these public health issues often have the least access to STEM resources. One factor limiting accessibility is the cost of precision measurement tools.

The development of low cost sensors is becoming more widespread in air quality research. These sensors typically monitor air quality indicators such as O<sub>3</sub>, NO<sub>2</sub> or CO<sub>2</sub>. High levels of these chemicals indicate pollution due to automobiles, factories, fewer organic materials, and other typical urban development.

A 2014 research publication at the University of Colorado Boulder summarized the development of a low-cost personal air quality monitor called “M-Pods (Figure 1).” These units measured Ozone (O<sub>3</sub>), Nitrogen Dioxide (NO<sub>2</sub>) Carbon



Monoxide (CO), Carbon Dioxide (CO<sub>2</sub>) and volatile organic compounds (VOCs). Through a series of user studies, the M-Pod was determined to be an effective low-cost tool for assessing personal pollutant exposure (Piedrahita et al., 2014). Later, the release of the crowd funded Air Quality Egg (Figure 1) marked a huge leap forward in community led urban air quality monitoring. This platform measures Nitrogen Dioxide (NO<sub>2</sub>) and Carbon Monoxide (CO), as well as temperature and humidity. Users remotely log data on a public online server (“Air Quality Egg,” n.d.).

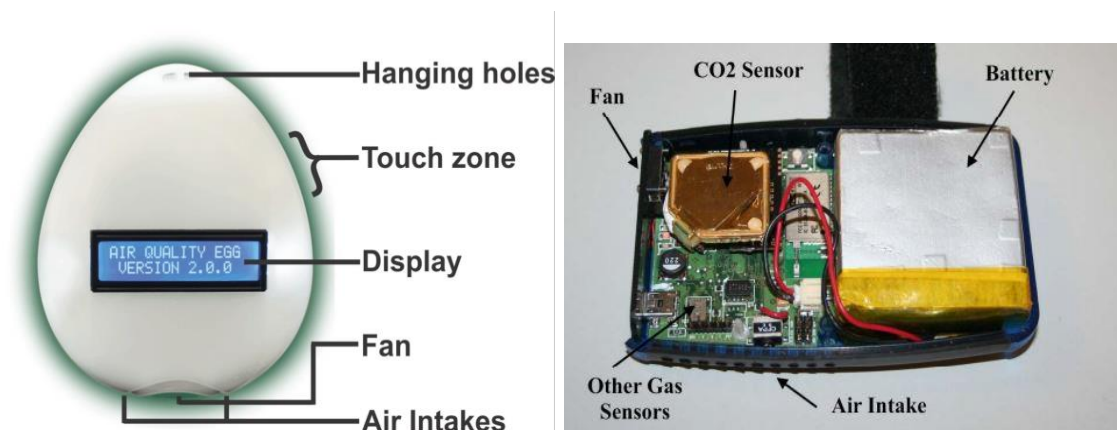

Figure 1: Diagram of Air Quality Egg Sensor Platform (Left) and M-Pod mobile sensor platform (right)

The Air Quality Egg illustrates another advantage of low cost sensor platforms: Driving down the cost of data collection implies a greater amount of data can be collected. If data can be collected by more people, the data can be combined to create more comprehensive analyses of urban environments and achieve greater spatial resolution. Projects such as the Citizen Science Alliance have attempted to leverage this, collecting widespread data while providing learning tools to those without classic STEM educations (“Citizen Science,” n.d.).

This project intends to explore the feasibility of using low-cost sensors and generic microcontrollers to create a more accessible system platform for measuring air quality. A number of potential trade-offs need to be considered when selecting sensors for a low-cost system (Table 1). Some significant disadvantages of using lower cost sensors include increased noise, lower

precision, and high cross-sensitivity. The objective of this thesis is to assess the feasibility of improving these platforms by lowering their cost to below \$200 and increasing their precision. In addition, the design of a new platform aims to open source all of its components to increase accessibility. In tandem with the Green Building Research Lab at Portland State University, sensors were surveyed, assessed through lab calibration, and integrated into a wireless data acquisition system. The result is a prototype low cost air quality monitoring system affectionately named "Mimi V1."

| <b>Platform</b>                | <b>Measurement</b>   | <b>Price</b> | <b>Advantages</b>   | <b>Disadvantage</b>  |
|--------------------------------|--|--------------|---|--|
| M-Pod                          | CO, CO2, VOCs, NO2, O3   | \$ 200       | Extremely low-cost metal oxide sensors (\$10 for several)       | Proprietary data acquisition system, high sensor drift, high cross-sensitivity interaction |
| Air Quality Egg                | NO2, CO  | \$ 100       | Low Cost, Connects to wide network                              | Sensor platform is limited to NO2 and CO   |
| Mimi V1                        | CO, CO2, T, RH, O3, PM 2.5   | \$200        | Wide variety of pollutant sensing, open source platform         | Some sensitivity interaction, higher cost, needs wifi network for remote data logging      |
| Portland Lafayette DEQ Station | T, BP, NEPH, NO, NO2, NOX, O3, PM 10, PM 2.5, RH, SIG, SOL RD, CO, SO2, WD, WS | \$30000      | High precision data of a large pallet of air quality parameters | Extremely high cost  |

*Table 1: Overview of 2 existing low cost air quality monitoring platforms, the Mimi V1 platform developed in this thesis, and an industry standard air quality management system*

## 2 Methods

### 2.1 Sensor Selection

Strategy for this project began with a thorough review of available off the shelf low cost air monitoring sensors. A docket of sensors was assembled for the monitoring of CO, CO<sub>2</sub>, O<sub>3</sub>, NO<sub>2</sub>, and particulate matter (PM), as well as temperature and humidity sensors. Review of these sensors was challenging. Most available low cost air monitoring sensors are designed for alerting the user to toxic levels of a substance. The range of these sensors lacked tolerances capable of accurately measuring ambient air conditions. In many cases, the tolerance of the sensor was larger than typical ambient air quantities. Pairing down of the sensors consisted of evaluating each sensor based on cost, range, accuracy, precision, and function. Table 2 summarizes these evaluations for the chosen sensors.

| Sensor     | Manufacturer | Function              | Range       | Precision            | Cost   |
|------------|--------------|-----------------------|-------------|----------------------|--------|
| SHT31-D    | Adafruit     | Temperature, Humidity | NA          | RH ± 2%, Temp ± 0.3% | 13.95  |
| SM50       | Aeroqual     | Ozone                 | 0-0.15PPM   | ±10 PPM              | 420.00 |
| MiCS-2614  | SensorTech   | Ozone                 | 10-10000PPM | NA                   | 33.15  |
| EC4-500-CO | SensorTech   | Carbon Monoxide       | 0-500PPM    | ±1 %                 | 49.92  |
| NA         | SenseAir     | Carbon Dioxide        | NA          | NA                   | NA     |
| PPD42      | Shinyei      | PM 2.5                | 1µm         | NA                   | 15.00  |

*Table 2: Specifications of Selected Air Quality Monitoring Sensors*

Evaluation of sensors resulted in a final design to monitor Ozone (O<sub>3</sub>), Carbon Monoxide (CO), Carbon Dioxide (CO<sub>2</sub>) and particulate matter (PM 2.5), as well as temperature and humidity.

Each sensor has unique challenges regarding wiring and signal processing. The following sections review wiring and calibration of each sensor.

## 2.2 Sensor Calibration

Sensor calibration took place in the Green Building Research Laboratory, which maintains air temperature and humidity of 23-25 C and 23-27 % respectively. The following calibrations give a rough idea of the response of the selected sensors. Realistically, metal oxide sensors are notorious for their cross sensitivity including reactions which vary by temperature and humidity. A temperature and humidity sensor are included in this platform to add cross sensitivity analysis to the sensor calibrations in future iterations.

### 2.2.1 SHT31-D Temperature and Humidity Sensor

The SHT31-D 2 is one of the most well documented sensors of the Mimi V1 platform. This sensor communicates using I2C and is pre-calibrated for temperature and relative humidity. This calibration was verified by placing the sensor in a range of temperature and humidity conditions while comparing the sensor reading to an industry standard instrument.

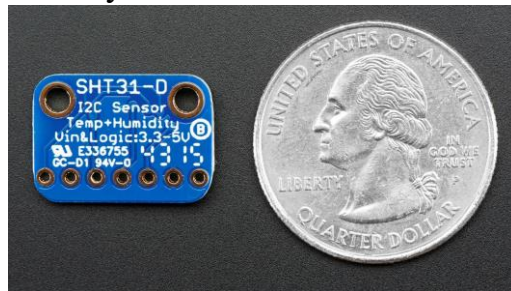
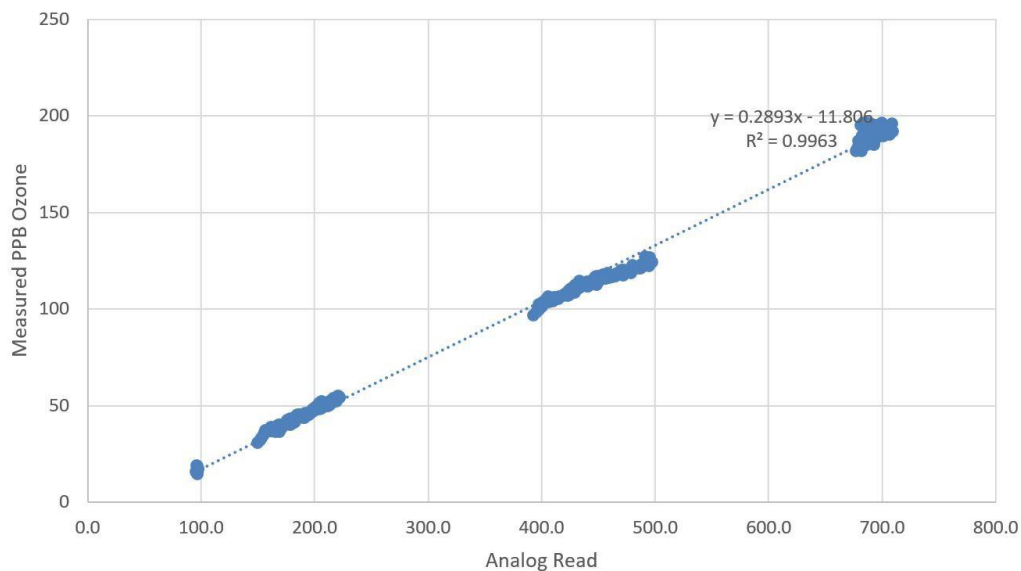

Figure 2: SHT31-D Temperature and humidity sensor by Adafruit

The calibration of the SHT31-D revealed a relatively long transient response time (up to 30 minutes) especially at high humidity levels.

### 2.2.2 SM50 Aeroqual Ozone Sensor

The Aeroqual SM50 Ozone sensor is one of the highest priced sensor explored in this project. This sensor includes a breakout board which can translate data into an analog read or several digital languages. Calibration of the SM50 was done using the analog read option of the pre- packaged sensor board. This reading was correlated to a 1023 bit reading on the Arduino MKR 1000 microcontroller (Figure3).



*Figure 3: First Calibration of SM50 Ozone Sensor*

The reference for this reading was a high quality ozone sensor attached to the same system. Compressed air flowed through tubing and filters, then through a chamber creating UV light. Ozone is created in this chamber. The amount of UV light applied to the chamber changed the

concentration of O<sub>3</sub> in the air. After the UV light chamber, air was sent through the high quality ozone sensor and through a sealed chamber containing the SM50 sensor 4. A waiting period of 45-60 minutes was necessary for a stable O<sub>3</sub> reading. The reading of the high quality sensor and the raw reading of the SM50 were compared to create the calibration curve used for Mimi V1.

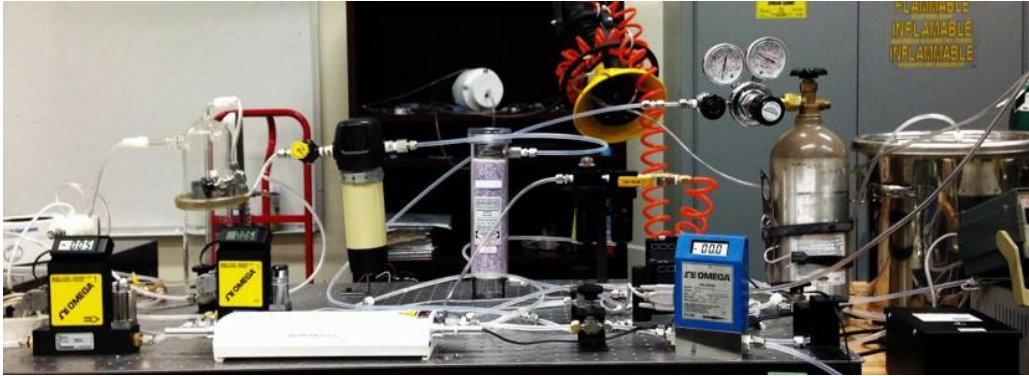

*Figure 4: Calibration apparatus for SM50 Ozone sensor*

A linear relationship is observed between the sensor output and the measured ozone concentration. Error increased as the sensor reached values above 160 PPB. This behavior is expected, as the specified range of the sensor is 0-150 PPB. Ambient ozone regulations set healthy levels below 70 PPB, and levels rarely exceed 100 PPB (EPA.gov).

### **2.2.3 MiCS-2614 Ozone Sensor**

The MiCS-2614 (Figure 5) is a metal oxide semiconductor sensor which responds to elevated levels of Ozone in the surrounding air. As Ozone levels change, oxidation occurs on the surface of the semiconductor changing the resistance of the sensor (Morrison, 1981). By measuring this change in resistance, a relationship is developed between the sensor output and ambient levels of ozone in the environment.



*Figure 5: MiCS-2614 Ozone Sensor by Sensortech*

Similarly to the SM50 sensor in the previous section, calibration of this sensor was performed using a stainless steel chamber circulating air and ozone. Air was filtered before continuously entering a chamber with a UV light. The reaction to this light causes ozone to be formed in the air. Varying the amount of UV light present changes the concentration of ozone 4. This concentration was varied and a voltage output was received by the Arduino MKR1000 microcontroller. This voltage reading was compared to a high quality ozone sensor reading to create a calibration curve (Figure 6).



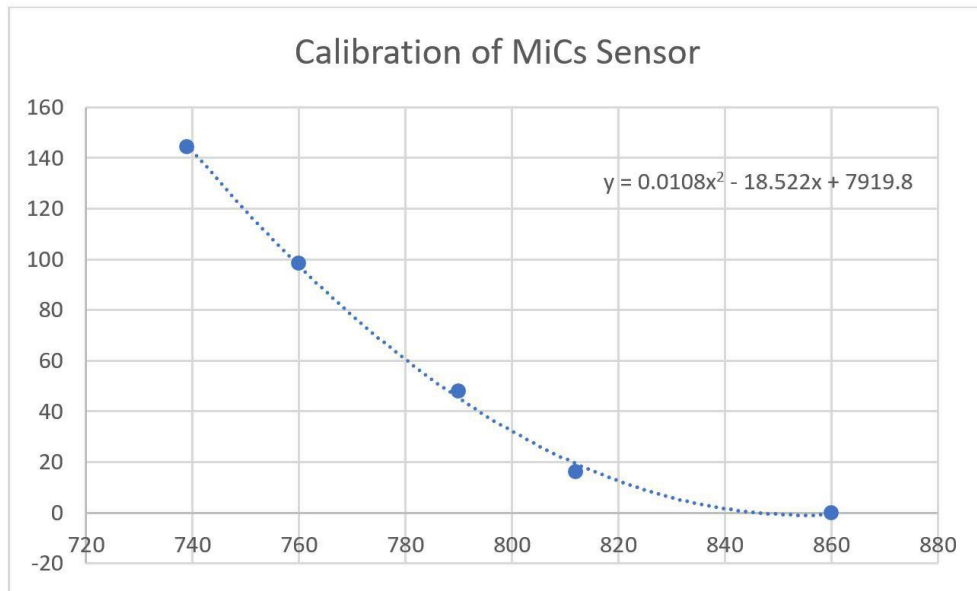

*Figure 6: First Calibration of MiCS-2614 Ozone Sensor*

Sensor drift appeared to be an issue with these tests. When the sensor receives constant power, the semiconductor gradually gains heat, which reduces the resistance of the sensor. Over time, the sensor output increases due to this change in resistance. Future iterations of this project will incorporate a real time clock (RTC) in an attempt to save power by only providing power to the sensor while taking readings. In this case, sensor drift as a result of time will not be an issue. To simulate this response, a second calibration for future iterations is scheduled to be performed. In this test, the sensor will be powered down for 1 hour between readings.

### 2.2.4 EC4-500-CO Carbon Monoxide Sensor

Data on the EC4-500-CO Carbon Monoxide Sensor was incomplete at the publishing of this thesis.

### 2.2.5 K30 Carbon Dioxide Sensor

The K30 CO<sub>2</sub> sensor includes a calibration which has already been uploaded to the sensor breakout board. This calibration was verified by creating known concentrations of CO<sub>2</sub> and comparing these concentrations with the sensor reading (Figure 7). Data collected illustrated a strong correlation between the calibrated sensor reading and the actual CO<sub>2</sub> calibration. A systematic error is present, with the sensor reading a mean of 112 PPM higher than the CO<sub>2</sub>

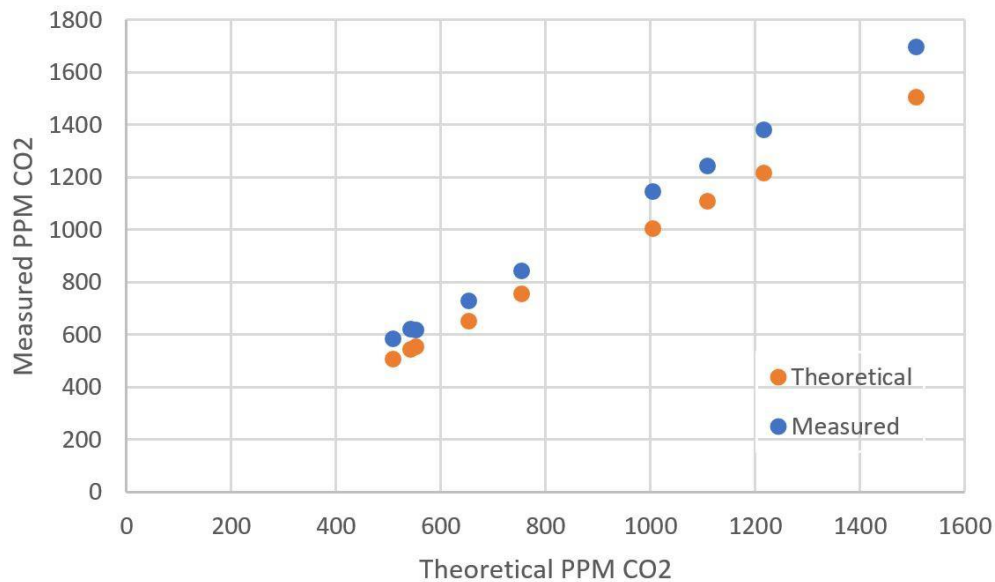

concentration.

Figure 7: Verification of Calibration of CO<sub>2</sub> Sensor

Integration of the CO<sub>2</sub> sensor included compensation of this systematic error.

Communication with the CO<sub>2</sub> sensor takes place over a serial I<sup>2</sup>C connection with the MKR1000.

### **2.2.6 PPD42 Particulate Matter Sensor**

*Calibration data of the Shinyei PM 2.5 sensor was unavailable during the writing of this draft.*

## **2.3 Data Acquisition**

Data acquisition and open loop controls for this system were done using the Arduino MKR1000. This microcontroller was chosen for its low cost (\$34.99), fast processing speed, and built in wifi chip. The wifi chip allows the system to log data remotely in any area with a wifi connection. The first prototype of this system reads each sensor and sends data via wifi to a shared Google Sheet. This sheet can be accessed to monitor the air quality of any remote location with a wifi connection. In addition, data is logged through a hardwired serial connection from the microcontroller to a computer. During system performance analysis, this connection serves as a redundancy in case of failure in remote data logging.

## **2.4 System Assembly**

The final sensor platform produced in this project contains the sensors reviewed in previous sections integrated with the MKR1000 to wirelessly transmit data via wifi network (Figure 8). For the tests performed, serial connection to a laptop was used as a redundancy against failure of wifi communication. The sensors and microcontrollers are packaged in a small box to minimize effects of ambient light. A small DC fan is also included in the system to help mix air that is entering the box (Figure 9).

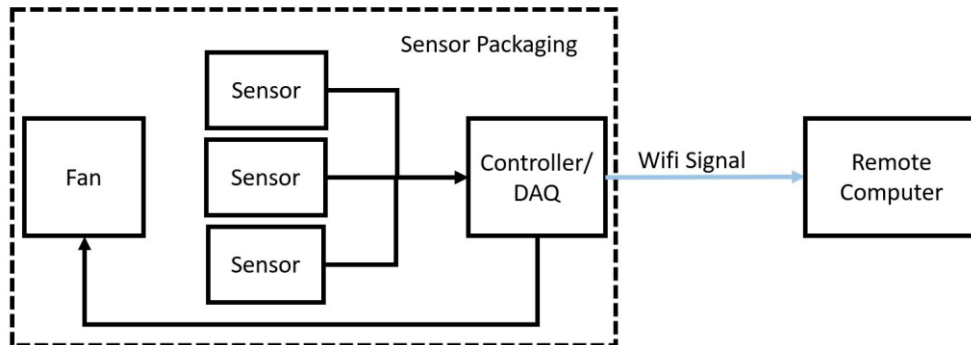

*Figure 8: Diagram of low cost air quality monitoring platform*

Mimi V1 required a standard AC wall power source to supply the platform continuously. Conversely, a port is available on the MKR 1000 to connect to a 3.3V Lithium Ion battery with approximately 8 hours of battery life. Future iterations of this platform plan to reduce power requirements of this system.

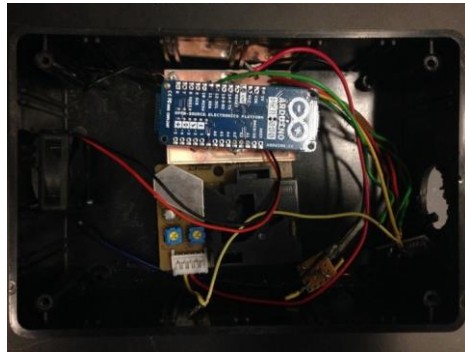

*Figure 9: Diagram of low cost air quality monitoring platform*

The calibrated system is tested at the Portland Lafayette DEQ Station in Southeast Portland. This state run weather station logs data hourly on the public Oregon DEQ website. Tests at this station occur over several hours on days with varying weather conditions. Collected data was

collocated with data collected by the industry standard weather station at this site.

### 3 Results

Data was collected hourly at the Portland Lafayette DEQ station and collocated with the industry standard equipment used at this station (Table 3). The PM 2.5 sensor collected data with average deviation from the DEQ data of 4.06 %. Although the SHT31-D claimed high accuracy, this sensor was had an average error of 32.8 percent. The SM50 sensor also failed to make accurate measurements at atmospheric levels of O<sub>3</sub>. Collocation of the K30 CO<sub>2</sub> sensor, MiCS-2614 O<sub>3</sub> sensor, and EC4-500-CO sensor were not completed due to time constraints.

| Sensor     | Function              | Spec Precision          | Actual % Deviation |
|------------|-----------------------|-------------------------|--------------------|
| SHT31-D    | Temperature, Humidity | RH +-2 %, Temp +- 0.3 % | Tem -32.8<br>RH NA |
| SM50       | Ozone                 | + -10 PPB               | -130               |
| MiCS-2614  | Ozone                 | NA                      | NA                 |
| EC4-500-CO | Carbon Monoxide       | + -1 %                  | NA                 |
| KG30       | Carbon Dioxide        | NA                      | NA                 |
| PPD42      | PM 2.5                | NA                      | -4.06 %            |

Table 3: Data collected at Lafayette DEQ station and collocated with industry standard instrumentation

## **4 Conclusion**

Results of the DEQ colocated data suggest that development of lower cost air quality monitoring equipment is feasible. Readings from the PM 2.5 sensor were with 5 percent of the industry standard calibration. More experiments are needed to determine the meaningfulness of data collected from the O<sub>3</sub>, CO<sub>2</sub>, and CO sensors. Verification of Mimi V1 was incomplete due to time constraints. This verification is necessary, as illustrated by the results of the SHT31-D temperature and humidity sensor. This sensor deviated over 30 % from its manufacturer's specification of error.

### **4.1 Future Steps**

Further verification experiments are required to determine the meaningfulness of the O<sub>3</sub>, CO<sub>2</sub>, and CO sensors. These experiments are scheduled to be conducted in Summer of 2017 in the Portland State University Green Building Research Laboratory. In addition, the circuit board has been debugged and revised for the next version of this prototype. Manufacturing and deployment is scheduled for Summer 2017.

Another future step is to reduce the power requirements of this system. Mimi V1 runs continuously, and is limited by battery power if it is not plugged into a continuous power source. Future iterations intend to explore systems with "sleep" options. In this scenario, the module would power down in between readings to save battery power. Remote data acquisition will also be addressed in future iterations of this project. The current

prototype uses wifi to transmit data, and is unable to remotely transmit data when a wifi network is not present. Future iterations will explore more versatile techniques for data transmission.

After the summer 2017 revision and deployment of this platform, data will be collected remotely over several months to monitor spatial difference in air pollution over urban ecoroofs and their traditional counterparts. These data will be processed as part of a project to model pollutants over ecoroofs and explore potential correlation between roof choice and indoor air quality.

## 4.2 Implications

The development of Mimi V1 is promising for the future of low cost, spatially specific air quality monitoring. Improvements to this system could result in more widespread use. It's affordability, mobility, and open source nature have potential for a great push forward in citizen science.

## References

- Air Quality Egg. (n.d.). Retrieved June 13, 2017, from <https://airqualityegg.wickeddevice.com/>
- Citizen Science. (n.d.). Retrieved June 13, 2017, from <http://citizenscience.org/>
- Gatziolis, D., Jovan, S., Donovan, G., Amacher, M., & Monleon, V. (2016). Elemental Atmospheric Pollution Assessment Via Moss-Based Measurements in Portland, Oregon. Retrieved from [https://www.fs.fed.us/pnw/pubs/pnw\\_gtr938.pdf](https://www.fs.fed.us/pnw/pubs/pnw_gtr938.pdf)
- Kumar, P., Morawska, L., Martani, C., Biskos, G., Neophytou, M., Di Sabatino, S., ... Britter, R. (2015). The rise of low-cost sensing for managing air pollution in cities. *Environment International*, 75, 199–205. <https://doi.org/10.1016/j.envint.2014.11.019>
- Morrison, S. R. (1981). Semiconductor gas sensors. *Sensors and Actuators*, 2, 329–341. [https://doi.org/10.1016/0250-6874\(81\)80054-6](https://doi.org/10.1016/0250-6874(81)80054-6)
- Piedrahita, R., Xiang, Y., Masson, N., Ortega, J., Collier, A., Jiang, Y., ... Shang, L. (2014). The next generation of low-cost personal air quality sensors for quantitative exposure

monitoring. *Atmospheric Measurement Techniques*, 7(10), 3325–3336.

<https://doi.org/10.5194/amt-7-3325-2014>