

Low Cost Obstacle Avoidance Robot

Vivek Hanumante, Sahadev Roy, Santanu Maity

Abstract— This paper deals with a low cost solution to obstacle avoidance for a mobile robot. This paper also presents a dynamic steering algorithm which ensures that the robot doesn't have to stop in front of an obstacle which allows robot to navigate smoothly in an unknown environment, avoiding collisions. The obstacle avoidance strategy has been described. Obstacle avoidance strategy and working of robot is greatly dependent on the detection of obstacles by sensors and corresponding response of robot. Working principle of sensors, limitation of their use and obstacle avoidance algorithm has been discussed in detail.

Index Terms— AVR Studio, Binary Logic, Dynamic steering algorithm, RS232.

I. INTRODUCTION

There are some very famous methods for robot navigation like wall-following, edge. One recently introduced commercial system uses wall-following method on a floor cleaning robot for long hallways [1]. A more general and commonly employed method for obstacle avoidance is based on edge detection [2, 3]. Real-time obstacle avoidance is one of the key issues to successful applications of mobile robot systems. A disadvantage with obstacle avoidance based on edge detecting is the need of the robot to stop in front of an obstacle in order to allow for a more accurate measurement. All mobile robots feature some kind of collision avoidance, ranging from primitive algorithms that detect an obstacle and stop the robot short of it in order to avoid a collision, through sophisticated algorithms, that enable the robot to detour obstacles. The latter algorithms are much more complex, since they involve not only the detection of an obstacle, but also some kind of quantitative measurements concerning the obstacle's dimensions. Once these have been determined, the obstacle avoidance algorithm needs to steer the robot around the obstacle and resume motion toward the original target [4]. In this paper the dynamic steering algorithm ensures that the robot doesn't have to stop in front of an obstacle during its navigation. Hence the robots may overcome some of the problems during navigation, discussed above and it can navigate smoothly during its operation avoiding the collisions. We have presented a basic algorithm and design which can be further improved depending upon the required applications.

II. BASIC DESIGN OF ROBOT

This obstacle avoidance robot was built with an ATMEGA-8 microcontroller development board. This board consists of two sensor ports connected to pin PC0 and PC3 of PORT C of ATMEGA-8 microcontroller.

Manuscript received September, 2013.

Vivek Hanumante, Department of Electronics & Communication Engineering, National Institute of Technology Arunachal Pradesh, India.

Sahadev Roy, Department of Electronics & Communication Engineering, National Institute of Technology Arunachal Pradesh, India.

Santanu Maity, Department of Electronics & Communication Engineering, National Institute of Technology Arunachal Pradesh, India.

There are two 60rpm DC motors used, positive terminal of right motor is connected to pin PB1, its negative terminal to pin PB2 and negative terminal of left motor is connected to pin PB3, its positive terminal to the pin PB4 of PORT B of the microcontroller.

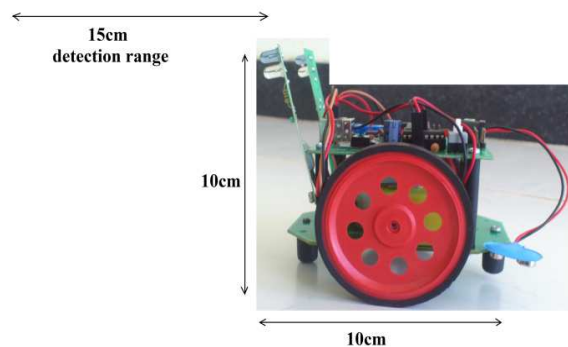

Fig.1: Range and Height of sensors

Detection range of sensors is 15cm which are 10cm above the surface level as shown in Fig.1.

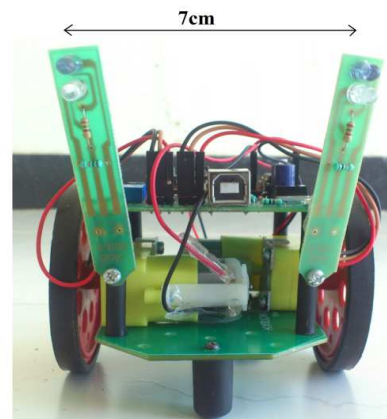

Fig.2: Position of sensors

Fig.2 shows the positions of the two sensors and distance between them, which can be altered to vary the effective area for obstacle detection.

III. SENSORS FOR OBSTACLE AVOIDANCE

There are varieties of sensor available those can be implemented for detection of obstacle. Some of the very popular sensors are: Infrared sensors, Cameras, which can be used as a part of Computer Vision, Sonar, LIDAR which can directly measure the distance of thousands to hundreds of thousands of points in its field of view [5]. Since reduction of cost is an important factor in the design of robot, we opted Infrared (IR) sensors for our low cost obstacle avoidance robot. IR sensors occupy lower ground in cost as compared other sensors. IR sensors provide the distance of objects directly in front of the sensor beam. This sensor can be used for most indoor applications where no important ambient Infrared light is present.

The IR sensor used, basically is of ‘always ON’ type. The sensor can be divided into two parts: Transmitter and Receiver. Transmitter has an IR LED (Tx), constantly emitting light and hence this sensor is known as always ON type.

The second part, Receiver consists of a photodiode (Rx). Transmitter keeps on emitting IR light, when there is any obstacle in the front of sensor, the emitted light get reflected back to the sensor. When reflected IR light beam falls on the photodiode, the voltage drop increases and the cathode’s voltage of photodiode goes low depending on the intensity of reflected light beam. This voltage drop can be detected using an Op-Amp (operational Amplifier LM358). From the working principle of Op-Amps, we can notice that the output will go High when the volt at the cathode of diode drops under a certain voltage. So the output will be High when IR light is detected, which is the purpose of the receiver [6]. Detection range of the sensor can adjusted using potentiometer/variable resistor (Vr) present in the sensor. An LED is also mounted for the indication of detection of obstacle. The circuit diagram for an IR sensor is shown in Fig.3.

Two IR Sensors were attached in front side of robot. Sensors were optimized in such a way that robot can detect the obstacle up to the range of 15cm.

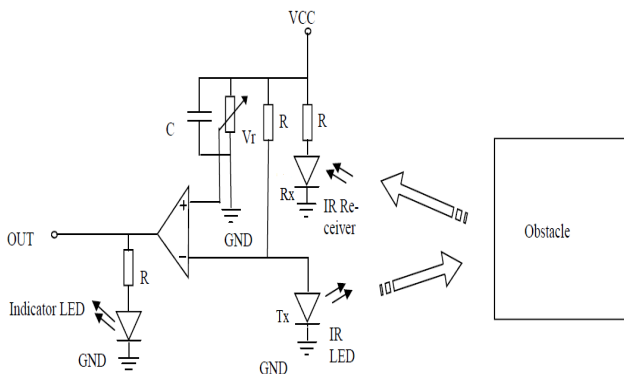

Fig.3: Functional Block Diagram /Schematic Diagram

IV. ALGORITHM - WORKING PRINCIPLE

By the virtue of working of sensors, when obstacle is detected, the reflected IR beam of can be considered as an input to the sensor. Taking the convention of Binary Logic, we can assume input to the sensor as logical ‘1’ when obstacle is detected and input can be called ‘0’ when there is no obstacle. Since two IR sensors have been used let us name them as LS for sensor in the left hand side and RS for sensor in the right hand side of the robot.

Similar to the sensors we can name the positive and negative terminals of DC motor in Left hand side as LMP and LMN respectively and positive and negative terminals of motor in Right hand side as RMP and RMN respectively. Here ‘1’ can be taken as output from microcontroller to the terminals of motor.

The robot will continuously roam detecting the obstacles and avoiding collision. When there is no obstacle both the sensors receives the input as ‘0’ and robot keeps on moving forward. If only Left sensor detects the obstacle i.e. LS=1, the robot turns right to avoid collision by keeping right wheel still (RMP=0) and moving left wheel (LMP=1). Similarly if only Right sensor detects the obstacle i.e. RS=1, the robot turns left

to avoid collision by keeping left wheel still (LMP=0) and moving Right wheel (RMP=1). In case if there comes an obstacle in front of the robot, both the sensors sense the obstacle i.e. LS=1, RS=1. At this stage robot turns back since left and right movement will not be possible.

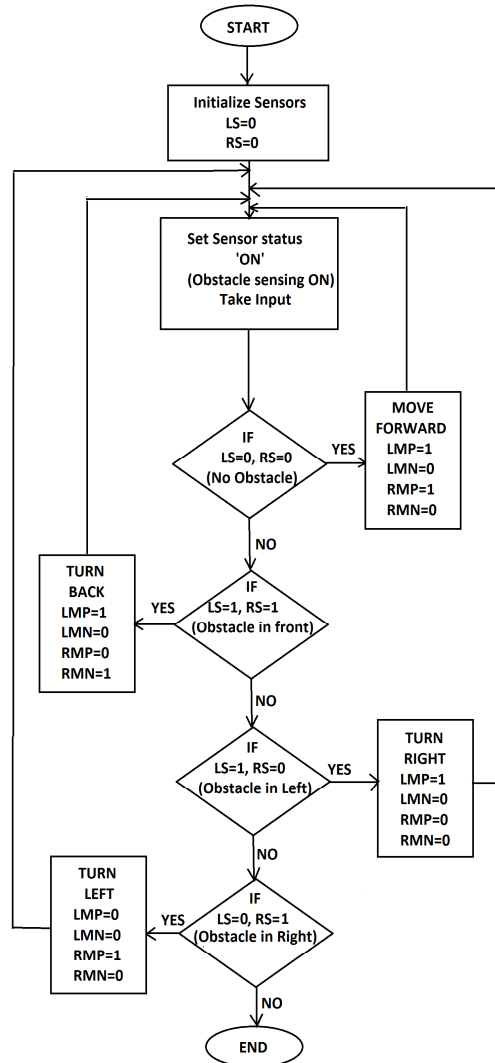

Fig.4: Flow chart for obstacle avoidance strategy. This can be achieved by moving left wheel in forward direction and right wheel in backward direction resulting in-place turning. The robot will continuously navigate and does not have to stop. The algorithm presented here defines the infinitely continuous movement of robot without any need to reach any specific target. Infinite loop of continuous obstacle detection has been presented. The obstacle avoidance strategy can be concluded in the flow chart shown in the fig.4.

V. IMPLEMENTATION

The implementation of obstacle avoidance strategy for robot involves the writing and compilation of program using software AVRStudio (version4). The compiled program from the PC has to be written on microcontroller on PCB or development board of the robot for which a serial communication has to be established. This is done by using a USB to RS232 conversion cable, and RS232 port is then connected to the MAX232 present on PCB which converts

TT Logic to Binary Logic [7]. Software HIDBootFlash (version1.0.0.1) was used to write program on development board using USB cable. Hence the program through MAX232 is written in microcontroller. Once program has been loaded to the microcontroller the robot can now roam around.

During the operation of robot, it continuously takes the input from photodiode of the IR Sensor. The input is compared in the LM358 comparator IC present in the IR Sensor. The output of the comparator is given to the microcontroller.

Microcontroller based upon the program takes decision and provides output for controlling the direction of robot. The output has to be sent to the motors but the output signal from microcontroller is not capable to drive the motors hence IC L293D is used for driving motors, it is also known as driver IC. All inputs of it are TTL compatible.

The general block diagram for the complete execution is as Follow:

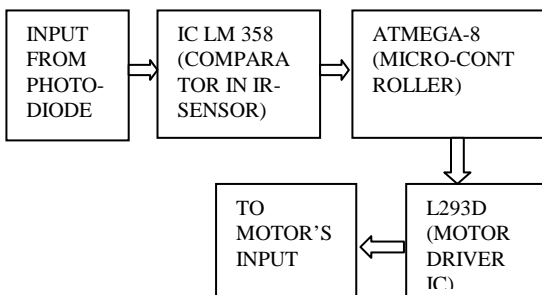

Fig.5: Block Diagram of obstacle avoidance robot

VI. SOFTWARE IMPLEMENTATION

The embedded C program code for the implementation of obstacle avoidance robot is given as follow:

```

/*connection setup for the obstacle avoidance robot
RMP(+ve terminal of right motor) ----- PB1
RMN(-ve terminal of right motor) ----- PB2
LMN(-ve terminal of left motor) ----- PB3
LMP(+ve terminal of left motor) ----- PB4
LEFT SENSOR(LS) ----- PC0
RIGHT SENSOR(RS) -----PC3
*/
#include<avr/io.h>
#include<util/delay.h>
void main()
{
    DDRC=0b0000000; /*set PORT C as input port*/
    DDRB=0b00011110; /*set PB1, PB2, PB3, PB4 as output pins*/
    int LS=0, RS=0; /* to acquire the left sensor status in LS and right sensor status in RS, define & initialize LS, RS integer as 0 */
    while(1) /* create infinite loop */
    {
        LS=(PINC&0b00000001); /*acquire only left sensor status, LS connected at PC0 */
        RS=(PINC&0b00001000); /* acquire only right sensor status, RS connected at PC3 */
        if((ls==0b00000001)&(rs==0b00001000)) /*check sensor status for both sensor ON- obstacle in front*/
        {
            PORTB=0b00010100; /* in-place turning of robot */
            _delay_ms(1800); /* keep on turning for 1.8 sec */

```

```

        LS=0; /*set sensor status OFF to further detect obstacle */
        RS=0; /*set sensor status OFF to further detect obstacle */
    }
    if((ls==0b00000001)&(rs==0b00000000)) /* check sensor status for left sensor(LS)=ON and right sensor(RS)=OFF */
    {
        PORTB=0b00010000; //turn right
        _delay_ms(500); //keep on turning right for 0.5 sec
        LS=0; /*set sensor status OFF to further detect obstacle */
        RS=0; /*set sensor status OFF to further detect obstacle */
    }
    if((ls==0b00000000)&(rs==0b00001000)) /* check sensor status for left sensor(LS)=OFF and right sensor(RS)=ON */
    {
        PORTB=0b00000010; /* turn left */
        _delay_ms(500); /*keep on turning left for 0.5 sec */
        LS=0; /*set sensor status OFF to further detect obstacle */
        RS=0; /*set sensor status OFF to further detect obstacle */
    }
    if((ls==0b00000000)&(rs==0b00000000)) /* check sensor status for both sensor OFF - no obstacle */
    {
        PORTB=0b00010010; //move forward
        LS=0; /* set sensor status OFF to further detect obstacle*/
        RS=0; /* set sensor status OFF to further detect obstacle*/
    }
}
}
}

```

VII. LIMITATION TO USE AND FURTHER IMPROVEMENTS

This robot has been successfully implemented for many obstacles like wall, chair, vessels, doors etc. but due to use of IR sensor it has certain limitation. We know that black and some other dark colours are good absorbent of light. IR light beams are also not reflected back from these coloured objects resulting into obstacle remaining undetected. Also efficient application of robot is limited only to indoor purposes.

Performance of this robot can be improved with the help of Bump sensors, for slow moving robots, Ultrasonic range sensors for large range up to 6m or LASER range finders [8]. One of the prevailing fields is the use of camera in robot, Computer vision can be implemented for better performance [5].

Differential Drive System: A mobile robot which uses differential drive has separate speed and direction control for the left and right sets of wheels. Such a system is very flexible for a mobile robot because it does not have a minimum turning radius, it can execute a turn around its own centre. Arc turning is achieved by driving the left and right wheels at different speeds. This ensures that the wheel speeds of the robot are lower while turning and faster when moving straight. Turning at high speeds can result in slipping and inaccurate turns, this prevents it from such happening [8]. Further improvements are Certainty Grid and The Virtual Force Field (VFF) Method [4].

VIII. CONCLUSION

Almost all navigation robot demands the some sort of obstacle detection, hence obstacle avoidance strategy is of utter importance. Obstacle avoidance robot has a vast field of application. They can be used as services robots, for the

purpose of household work and so many other indoor applications. Equally they have great importance in scientific exploration and emergency rescue, there may be places that are dangerous for humans or even impossible for humans to reach directly, then we should use robots to help us. In those challenging environments, the robots need to gather information about their surroundings to avoid obstacles. Nowadays, even in ordinary environments, people also require that robots can detect and avoid obstacles. For example, an industrial robot in a factory is expected to avoid workers so that it won't hurt them. In conclusion, obstacle avoidance is widely researched and applied in the world, and it is probable that most robots in the future should have obstacle avoidance function.

REFERENCES

- [1] Engelberger, J., Transitions Research Corporation, private communication, 1986.
- [2] Borenstein, J., "The Nursing Robot System." Ph. D. Thesis, Technion, Haifa, Israel, 1987.
- [3] Borenstein, J. and Koren, Y., "Obstacle Avoidance With Ultrasonic Sensors." IEEE Journal of Robotics and Automation. Vol. RA-4, No. 2, 1988, pp. 213-218.
- [4] Borenstein, J. and Koren, Y., "Real-time Obstacle Avoidance for Fast Mobile Robots." IEEE Transactions on Systems, Man, and Cybernetics, Vol. 19, No. 5, Sept./Oct. 1989, pp. 1179-1187.
- [5] Paul Kinsky and Quan Zhou, "Obstacle Avoidance Robot." Major Qualifying Project Report, WORCESTER POLYTECHNIC INSTITUTE, Project Number: YR-11E1.
- [6] Ibrahim KAMAL, "Infra-Red Proximity Sensor Part 1." Article, Sensor & Measurement, January 22, 2008. Available: <http://www.ikalogic.com>
- [7] Harivardhagini S., Pranavanand S and Ghali Bharadwaja Sharma, "Voice Guided Robot Using LabVIEW." CVR Journal of Science and Technology, Volume 3, December 2012.
- [8] Jnaneshwar Das, Mrinal Kalakrishnan and Sharad Nagappa, "Obstacle Avoidance for a Mobile Exploration Robot with Onboard Embedded Ultrasonic Range Sensor", PES Institute of Technology, Bangalore.



Vivek Hanumante is currently pursuing B.Tech degree in the Department of Electronics & Communication Engineering at NIT, Arunachal Pradesh and would be graduating in summer 2014. He has undertaken various microcontroller and FPGA based projects. His field of interest includes Embedded System & VLSI Design, Microwave. He was selected 9th BEST among top 50 performers of Winter Internship & Training Program-2012 by Techinnovates Embedded Solutions, Chennai.



Sahadev Roy is currently working as an Assistant Professor in the Department of Electronics & Communication Engineering at NIT, Arunachal Pradesh, India. He has more than 9 years Experience in research and teaching field. He received his B.Tech degree in ECE and M.Tech, in Mechatronics from Bengal Engineering and Science University, Shibpur, India. He is pursuing PhD in VLSI from NIT, AP. He has published a number of scientific papers in National and International Journals. His research interest includes Robotics, Microwave and VLSI design.



Santanu Maity, obtained his M.Tech in Radiophysics and Elec-tronics from Calcutta University, Rajabazar Science college and perusing Ph.D. in Solar photovoltaics from Center of Excellence for Green Energy and Sensor Systems(CEGESS),kolkata. He worked on RF MEMS based switch, MEMS based gas sensor, Crystalline solar cell etc. He has more than three years re-search experience on Microelectronics. Currently he is working as an Assistant professor of in Department of Electronics & Communication Engineering at National Institute of Technology, Arunachal Pradesh.