

Low-Power Wearable ECG Monitoring System for Multiple Patient Remote Monitoring

G. Karthikeyni
Applied Electronics/ECE
Selvam College of Technology

S. Arulmurugan /AP/ECE
AP/ECE
Selvam College of Technology

Abstract- Many devices and solutions for remote ECG monitoring have been proposed in the literature. These solutions typically have a large marginal cost per added sensor and are not seamlessly integrated with other smart home solutions. Here we propose an ECG remote monitoring system that is dedicated to non-technical users in need of long-term health monitoring in residential environments and is integrated in a broader Internet of-Things (IoT) infrastructure. Our prototype consists of a complete vertical solution with a series of advantages with respect to the state of the art, considering both prototypes with integrated front end and prototypes realized with off-the-shelf

components: i) ECG prototype sensors with record-low energy per effective number of quantized levels, ii) an architecture providing low marginal cost per added sensor/user, iii) the possibility of seamless integration with other smart home systems through a single internet-of-things infrastructure.

1.INTRODUCTION

Electrocardiography (ECG or EKG) is the process of recording the electrical activity of the heart over a period of time using electrodes placed on the skin. These electrodes detect the tiny electrical changes on the skin that arise from the heart muscle's electrophysiological pattern of depolarizing and repolarizing during each heartbeat. It is a very commonly performed cardiology test.

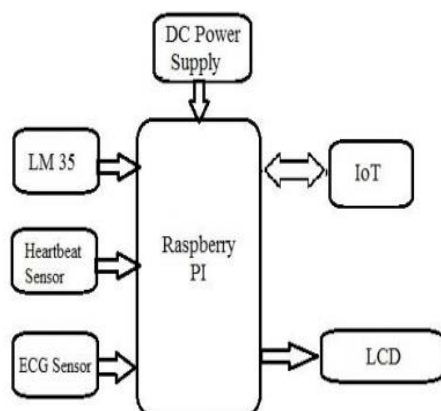

Fig 1. Block Diagram of Proposed System

During each heartbeat, a healthy heart has an orderly progression of depolarization that starts with pacemaker cells in the sinoatrial node, spreads out through the atrium, passes through the atrioventricular node down into the bundle of His and into the Purkinje

fibers, spreading down and to the left throughout the ventricles. This orderly pattern of depolarization gives rise to the characteristic ECG tracing. To the trained clinician, an ECG conveys a large amount of information about the structure of the heart and the function of its electrical conduction system.^[5] Among other things, an ECG can be used to measure the rate and rhythm of heartbeats, the size and position of the heart chambers, the presence of any damage to the heart's muscle cells or conduction system, the effects of cardiac drugs, and the function of implanted pacemakers.

2.LITERATURE REVIEW

Literature review cardiovascular diseases (CVDs) account for 45% of all deaths in the western world according to the 2004 World Health Organization statistics report. Heart failure (HF), CVD's primary paradigm, mainly affects people older than 65. The European My Heart Project's mission is to empower citizens to fight CVD by leading a preventative lifestyle and allowing early diagnosis. This paper presents the iterative design and development of the HF management system, part of MyHeart Project. The system daily measures vital body signals to assess HF. The methodology applied herein has involved stakeholders in an iterative process: concept validation, feasibility, efficiency, patients' experience, and patients' acceptance. The final solution allows patient self-management of their chronic condition.

In the existing system, ECG sensor nodes are based on a dedicated integrated front end, that sometimes includes a DSP, and require a second off-the-shelf chip to implement the radio link. However, power consumption mostly in such sensors is mainly due to the radio link and therefore the optimization obtained by the use of the dedicated front-end has a limited impact on the power performance of the complete sensor. In addition, the following sections will show that a general purpose high-performance and high resolution standard ADC can outperform the noise performance of many dedicated front-end chips. The disadvantage of this system is it increases cost per patient. It may not work, if the wireless infrastructure of the system gets changed.

There are many important health aspects in human body. If one of them has any change, sometimes it shows heavy effects in human health condition. In that case, breathing rate, blood pressure and temperature variations. By measuring the health aspects, the overall

body condition has been controlled. These are considered as important health aspects. Blood pressure level, temperature variation, heartbeat rate and breathing rate are monitored using the application of embedded system and the captured signals are transferred using GSM based communication technology.

3.SYSTEM DESIGN

Development of Smart Case for a health monitoring system with Raspberry PI has been discussed in this section. The platform has three main parts: the sensor and actuator networks, the IoT server and the user interfaces for visualization and management. Lightweight wearable ECG sensors and other ambient sensors collect data and send them in real time via a wireless protocol to a gateway connected to the home router. The architecture has been developed with the aim of enabling the integration of sensor networks based on different networks protocols. The IoT server converts the raw payload from heterogeneous nodes into a “universal” format, containing object identifier, object type, measurement unit, data field, geographical position, and timestamp.

Then, it makes the data available to applications and users. The wearable ECG sensor consists of a dry plastic electrodes and the electronic printed circuit board. The circuit extracts, filters, amplifies and digitizes the ECG signal, which is then acquired by the microcontroller and wireless sent to the IoT server.

The sensor and actuator networks, the IoT server and the user interfaces for visualization and management. Lightweight wearable ECG sensors and other ambient sensors collect data and send them in real time via a wireless protocol to a gateway connected to the home router. The architecture has been developed with the aim of enabling the integration of sensor networks based on different networks protocols. The IoT server converts the raw payload from heterogeneous nodes into a “universal” format, containing object identifier, object type, measurement unit, data field, geographical position, and timestamp. Then, it makes the data available to applications and users. The wearable ECG sensor consists of a dry plastic electrodes and the electronic printed circuit board. The circuit extracts, filters, amplifies and digitizes the ECG signal, which is then acquired by the microcontroller and wireless sent to the IoT server.

The PIC start plus development system from microchip technology provides the product development engineer with a highly flexible low cost microcontroller design tool set for all microchip PIC micro devices. The pic start plus development system includes PIC start plus development programmer and MPLAB IDE.

The PIC start plus programmer gives the product developer ability to program user software in to any of the supported microcontrollers. The PIC start

plus software running under MPLAB provides for full interactive control over the programmer. PCB stands for Printed Circuit Board. The naming convention will be clear once steps for the design are understood. On a lower level of project, PCBs are usually designed on a board whose one side is lined with copper. But on the industrial scale or on a professional level, it is preferred to have a double sided PCB. This also complexes the procedure through which PCBs are made. This document only emphasizes on PCB designing in PROTEUS 7.10 sp0. Other versions of PROTEUS may have similar steps but you might need to be cautious anyway.

4.HARDWARE DESIGN

4.1 Heartbeat Sensor

The Heart Beat Sensor provides a simple way to study the heart's function. This sensor monitors the flow of blood through Finger. As the heart forces blood through the blood vessels in the Finger, the amount of blood in the Finger changes with time. The sensor shines a light lobe (small High Bright LED) through the ear and measures the light that is transmitted to LDR. The signal is amplified, inverted and filtered, in the Circuit .By graphing this signal, the heart rate can be determined, and some details of the pumping action of the heart can be seen on the graph which is shown below.

In old versions, when a heart beat is detected a radio signal is transmitted, which the receiver uses to determine the current heart rate. This signal can be a simple radio pulse or a unique coded signal from the chest strap (such as Bluetooth, ANT, or other low-power radio link); the latter prevents one user's receiver from using signals from other nearby transmitters (known as cross-talk interference).

Newer versions include a microprocessor which is continuously monitoring the heartbeat rate and calculating the heart rate, and other parameters. These may include accelerometers which can detect speed and distance eliminating the need for foot worn devices. The sample result of heartbeat sensor is shown below.

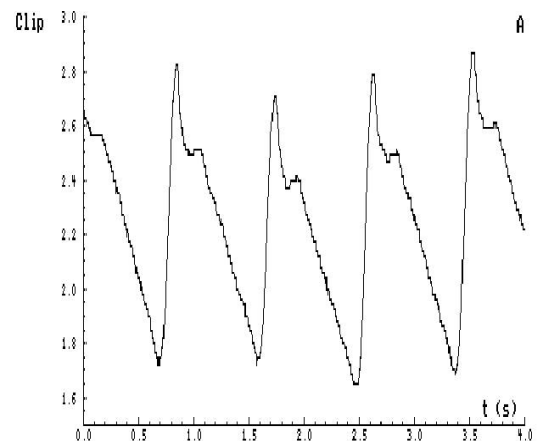

Fig 3.The Sample Result of Heartbeat Sensor

The above figure shows that the blood flowing through the Finger rises at the start of the heartbeat. This is caused by the contraction of the ventricles forcing blood into the arteries. Soon after the first peak a second, smaller peak is observed. This is caused by the shutting of the heart valve, at the end of the active phase, which raises the pressure in the arteries and the earlobe.

There are a wide number of receiver designs, with various features. These include average heart rate over exercise period, time in a specific heart rate zone, calories burned, breathing rate, built-in speed and distance, and detailed logging that can be downloaded to a computer.

4.2. Temperature sensor

The LM35 series are precision integrated-circuit temperature sensors, whose output voltage is linearly proportional to the Celsius (Centigrade) temperature. The LM35 thus has an advantage over linear temperature sensors calibrated in ° Kelvin, as the user is not required to subtract a large constant voltage from its output to obtain convenient Centigrade scaling.

The LM35 does not require any external calibration or trimming to provide typical accuracies of $\pm 1/4^{\circ}\text{C}$ at room temperature and $\pm 3/4^{\circ}\text{C}$ over a full -55 to $+150^{\circ}\text{C}$ temperature range. Low cost is assured by trimming and calibration at the wafer level. The LM35's low output impedance, linear output, and precise inherent calibration make interfacing to readout or control circuitry especially easy. It can be used with single power supplies, or with plus and minus supplies. As it draws only $60\ \mu\text{A}$ from its supply, it has very low self-heating, less than 0.1°C in still air.

The LM35 is rated to operate over a -55° to $+150^{\circ}\text{C}$ temperature range, while the LM35C is rated for a -40° to $+110^{\circ}\text{C}$ range (-10° with improved accuracy). The LM35 series is available packaged in hermetic TO-46 transistor packages, while the LM35C, LM35CA, and LM35D are also available in the plastic TO-92 transistor package. The LM35D is also available in an 8-lead surface mount small outline package and a plastic TO-220 package.

The LM35 can be applied easily in the same way as other integrated-circuit temperature sensors. It can be glued or cemented to a surface and its temperature will be within about 0.01°C of the surface temperature. These devices are sometimes soldered to a small lightweight heat fin, to decrease the thermal time constant and speed up the response in slowly-moving air. On the other hand, a small thermal mass may be added to the sensor, to give the steadiest reading despite small deviations in the air temperature. This is especially true if the circuit may operate at cold temperatures where condensation can occur.

4.3 Pressure Module

Home monitoring could be used for many purposes instead of ambulatory blood pressure monitoring. Home monitoring may be used to improve hypertension management and to monitor the effects of lifestyle changes and medication related to blood pressure. Ambulatory

monitoring is recommended for most patients before the start of antihypertensive drugs. When measuring blood pressure, an accurate reading requires that one not drink coffee, smoke cigarettes, or engage in strenuous exercise for 30 minutes before taking the reading. A full bladder may have a small effect on blood pressure readings; if the urge to urinate arises, one should do so before the reading. For 5 minutes before the reading, one should sit upright in a chair with one's feet flat on the floor and with limbs uncrossed. The blood pressure cuff should always be against bare skin, as readings taken over a shirt sleeve are less accurate. During the reading, the arm that is used should be relaxed and kept at heart level, for example by resting it on a table.

For the pressure threshold, we want to use a value representing the full weight of the subject's arm, indicating that their muscles are completely relaxed. By observing the values generated by lightweight users, and set the cut-off slightly below these values, at 500 out of a maximum of 1023. If support is provided, most people will automatically relax their arm fully. For the purpose of the user study, this thread also keeps a counter that is used to calculate the percentage of the time each metric was correct at the end of the measurement.

5. IOT BOARD

Introducing a new ESP8266 Development Board with an ESP-12, a 3x AA battery holder, a voltage regulator, an RGB LED, several red LEDs, and a light sensor LDR on the ADC input all on one board. The board can be controlled by an open source Android App which is available from the AI-THINKER Website. GPIO pins are extended with berg pins for easy external connections. RXD, TXD & GND pins are provided for programming / firmware upgrading. A yellow jumper is provided to pull GPIO0 pin to GND during programming. During normal operation this jumper must be removed. The board is powered by 3 nos AA batteries, for which a battery box is already wired. On board 3.3v regulator is provided for a stable power supply. No power switch or Reset switch is provided. To switch off you need to pull out one of the batteries. The board comes pre-loaded with a demo which does actually seem to work. If you have an Android based phone or tablet you can download AI-Thinker's app to control and mix the color balance on the RGB LED and to switch the other LEDs on and off.

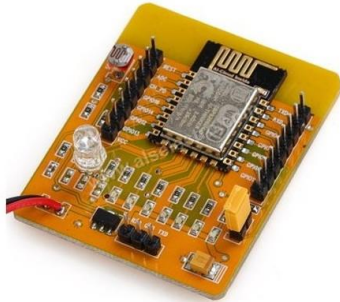

Fig 4.IOT Board

6.CONCLUSION

We have proposed a wireless wearable ECG monitoring system embedded in an IOT platform that integrates heterogeneous nodes and applications, has a long battery life, and provides a high-quality ECG signal. The system allows monitoring multiple patients on a relatively large indoor area (home, building, nursing home, etc.). Another remarkable feature of our system is a very low marginal cost per added sensor, since our architecture enables a single low-cost gateway to manage multiple sensors. Future work will focus on monitoring additional health related parameters using a broader combination of transducers, sensors, and correlation techniques, and on improving system reliability and robustness to patient movement and connectivity losses.

REFERENCES

- [1] S. Adibi, "Link Technologies and BlackBerry Mobile Health (mHealth) Solutions: A Review," *IEEE Trans. Inf. Technol. Biomed.*, vol. 16, no 4, Jul. 2012.
- [2] C. C. Y. Poon, Y.-T. Zhang, and S.-D. Bao, "A Novel Biometrics Method to Secure Wireless Body Area Sensor Networks for Telemedicine and M-Health," *IEEE Commun.Mag.*, April 2006.
- [3] A. J. Jara, M. A. Zamora-Izquierdo, and A. F. Skarmeta, "Interconnection Framework for mHealth and Remote Monitoring Based on the Internet of Things," *IEEEJSAC*, vol. 31, no. 9, Sept. 2013.
- [4] R. Carroll *et al.*, "Continua: An Interoperable Personal Healthcare Ecosystem," *IEEE Pervasive Computing*, vol.6, no. 4, Oct.-Dec. 2007.
- [5] M. Chen *et al.*, "Body Area Networks: A Survey," *ACM/Springer Mobile Networks and Applications (MONET)*, Feb. 2011, DOI: 10.1007/s11036-010-0260-8.
- [6] L. Pecchia, P. Melillo, and M. Bracale, "Remote Health Monitoring of Heart Failure with Data Mining via CART Method on HRV Features," *IEEE Trans. Biomed. Eng.*, vol. 58, no. 3, March 2011, pp.800-04, doi: 0.1109/TBME.2010.2092776.
- [7] M. K. Suh *et al.*, "A Remote Patient Monitoring System for Congestive Heart Failure," *J. Medical Systems (JOMS)*, May 2011.

5.1 Piezo buzzer

A piezo buzzer is a device that uses the piezoelectric effect, to measure the changes that occur in pressure, acceleration, strain or force by converting them to an electrical charge.



Fig 5.Piezoelectric Effect

5.2 Piezoelectric effect

The piezoelectric effect is understood as the linear electromechanical interaction between the mechanical and the electrical state in crystalline materials with no inversion symmetry (the internal generation of electrical charge resulting from an applied mechanical force). The contacts are closed by a magnetic field generated when current passes through a coil around the glass tube. Reed relays are capable of faster switching speeds than conventional relays. See also reed switch.