

Low Power Wireless Sensor Network for Building Monitoring

Tom Torfs, Tom Sterken*, Steven Brebels, Juan Santana[†], Richard van den Hoven[†], Chris Van Hoof

IMEC, Leuven, Belgium;

*IMEC / Ghent University, Ghent, Belgium;

[†]IMEC / Holst Centre, Eindhoven, The Netherlands

Contact e-mail : torfst@imec.be

Nicolas Sailien, Nicolas Bertsch*, Davide Trapani⁺, Daniele Zonta[†], Paris Marmaras^o, Matthaios Bimpas^x

Thermo Fisher Scientific, Enschede, The Netherlands

*MEMSCAP, Crolles, France;

⁺University of Trento, Trento, Italy;

^oNetScope Solutions, Athens, Greece; ^xICCS, Athens, Greece

Abstract— A wireless sensor network is proposed for monitoring buildings to assess earthquake damage. The sensor nodes use custom-developed capacitive MEMS strain and 3D acceleration sensors and a low power readout ASIC for a battery life of up to 12 years. The strain sensors are mounted at the base of the building to measure the settlement and plastic hinge activation of the building after an earthquake. They measure periodically or on-demand from the base station. The accelerometers are mounted at every floor of the building to measure the seismic response of the building during an earthquake. They record during an earthquake event using a combination of the local acceleration data and remote triggering from the base station based on the acceleration data from multiple sensors across the building. A low power network architecture was implemented over an 802.15.4 MAC in the 900MHz band. A custom patch antenna was designed in this frequency band to obtain robust links in real-world conditions.

I. INTRODUCTION

Buildings can progressively accumulate damage during their operational lifetime, due to seismic events, unforeseen foundation settlement, material aging, design error, etc. Periodic monitoring of the structure for such damage is therefore a key step in rationally planning the maintenance needed to guarantee an adequate level of safety and serviceability. However, in order for the installation of a permanently installed sensing system in buildings to be economically viable[1], the sensor modules must be wireless to reduce installation costs, must operate with a low power consumption to reduce servicing costs of replacing batteries, and use low cost sensors that can be mass produced such as MEMS sensors. The capability of MEMS and wireless networking for monitoring civil structures is well documented [2][3][4]. The presented work addresses all of the above requirements.

II. SYSTEM ARCHITECTURE

A. Network architecture

The monitoring system consists of two types of sensor modules: strain sensing modules and acceleration sensing

modules. They are placed in the building as shown in Fig. 1. The strain sensor modules are mounted at the lowest level of the building, to estimate the vertical column loads and any variation due to settlement. Horizontal acceleration is measured by two 3D acceleration sensing modules (where only the two horizontal axes are really required) at each level during an earthquake, allowing analysis of the seismic response of the whole structure. A typical 7-story, 24-column building requires approx. 72 strain sensors (3 per column) and 14 accelerometer modules (2 per floor).

The data is wirelessly transmitted to a nearby base station using a line of sight link with a range of >1km. The line of sight link uses directional antennas to improve the link budget, but not so directional that alignment is required, which could pose a problem during seismic events. The receiver base station can store and process the data or forward them, immediately or later, using classical wide area network connection technology. In this way, provided all modules as well as the receiver base station have battery back-up power, the data acquired during seismic events can be properly recorded even in case of outages of the electric power and/or communication networks.

In order to form a robust wireless link from all modules, including the strain sensor modules at the basement of the building, towards the receiver base station, a multi-hop network architecture is used as shown in Fig. 1. On the roof of

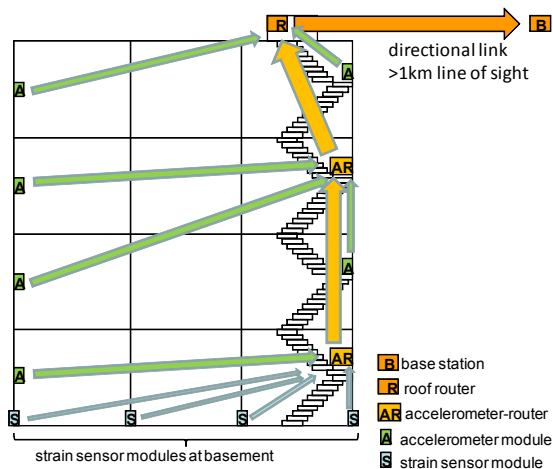

Figure 1. Architecture of the sensor network for building monitoring

the building a dedicated router module (without sensor) is placed to forward the data between the sensor network and the receiver base station. Some accelerometer modules on intermediate floors can be configured as additional intermediate routers when required to obtain a robust link from all sensor modules in the building towards the roof router module. As shown on Fig. 1, it is recommended to place the router modules in or close to the stairwell for improved vertical floor-to-floor propagation through the building.

For lowest power consumption in the sensor modules, the network is implemented using indirect data transfer using polling on top of a standard 802.15.4 MAC. In this way, the end nodes' radio is powered down most of the time. Only the routers and base station have their receivers constantly on. To avoid rapid battery depletion, the modules with router functionality are mains-powered through an AC/DC adapter, with the battery serving only for back-up power in case mains power is interrupted. The end nodes are battery powered only.

B. Sensor module architecture

The block diagram of the sensor modules is shown in Fig. 2 and a picture in Fig. 3. Both the accelerometer and strain sensing variants of the module use the same core components. For installation into the building these components are placed into a standard off-the-shelf plastic casing that can be conveniently mounted on the floor, wall or ceiling using screws, and offering access for sporadic battery replacement if needed. The core components are:

1) A custom-developed low power capacitive sensor read-out ASIC [5]. This ASIC can be matched to either MEMS-based comb finger capacitive accelerometers or strain sensors in a half-bridge configuration. Its gain can be set by a number of integration pulses N , optimizing signal-to-noise ratio and bandwidth with power. In addition, the architecture suppresses residual motion artifacts. In combination with the MEMS strain sensor, it can measure a range of $\pm 20,000\mu\epsilon$ with a resolution of $10\mu\epsilon$ and non-linearity $<0.6\%$. In combination with the MEMS accelerometer it can measure an acceleration range of $\pm 2.5g$ with a resolution of 80dB (13-bit) for vibrations between 10-100Hz and a non-linearity $<1\%$.

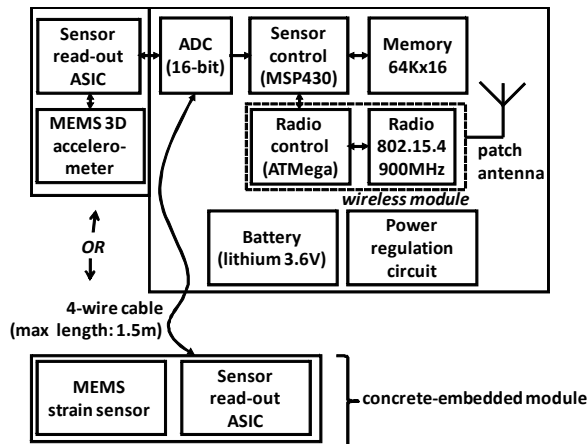

Figure 2. Block diagram of the sensor module with either a built-in accelerometer or a separate strain sensor module embedded in the concrete

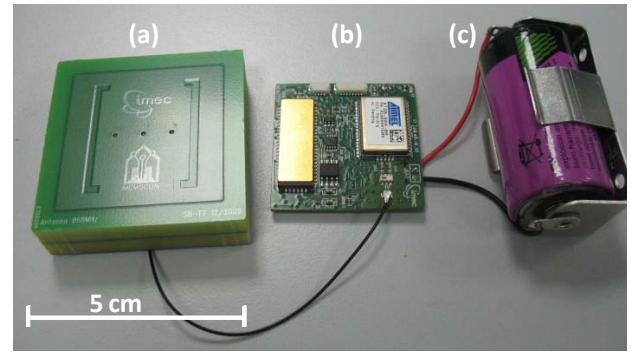

Figure 3. Picture of the wireless sensor module: (a) antenna, (b) electronics, (c) battery

- 2) A low power 16-bit successive-approximation analog-to-digital converter (Analog Devices AD7683).
- 3) A low power microcontroller (TI MSP430) to control the sensor data acquisition and temporarily store the data in a 64Kx16bit SRAM memory (Cypress CY62126).
- 4) A low power wireless IEEE 802.15.4-compatible module (Atmel ATZB-900) operating in the 900MHz band. This frequency band was chosen in preference to the more common 2.4GHz band because it offers a larger propagation range for the wireless communication. The wireless module includes a radio chip (Atmel AT86RF212) and a baseband microcontroller (Atmel AVR) which needs to be active only during wireless communication events.
- 5) A custom patch antenna was designed for the modules. The patch antenna is tuned for 868MHz operation with an efficiency of 51% using standard FR4 material as the substrate. Its size is $5 \times 5 \times 1.3 \text{ cm}^3$. Its shape and radiation pattern is optimized for wall-, floor- and ceiling-mounting in the building.
- 6) The modules are powered by a an 8.5Ah C-cell long operating life primary Lithium Thionyl Chloride battery (Tadiran SL-2770), suitable for 10 to 25 years of operation.

The accelerometer consists of 2 transverse comb finger structures for the X and Y axis and a pendulating one for the Z axis and was fabricated with a surface micro-machined process from a $85\mu\text{m}$ thick SOI wafer. It has 78 fingers with a total sensitivity of 2.02pF/g . The Z sensor has an area of 2.17mm^2 per plate. Innovative cap through connections were used. The main tradeoff in the design of the accelerometer is the sensitivity-bandwidth-linearity in all three axes, a challenge for the design given the different used structures. The XY and Z accelerometers are packaged together with the readout ASIC into a system-in-a-package and then mounted onto the printed circuit board as can be seen on Fig. 3.

The MEMS strain sensor is a longitudinal comb finger capacitor. The strain sensor fabrication procedure starts with a SOI wafer with a $500\mu\text{m}$ thick handle, $50\mu\text{m}$ thick fingers and $2\mu\text{m}$ thick oxide layer with 400 fingers in the sensor and it has a sensitivity of $0.133\text{fF}/\mu\epsilon$. Two anchors were etched-out of the surface to create the necessary clamps to attach the sensor to the rebar of a pillar. The fingers are protected with a borosilicate class cap.

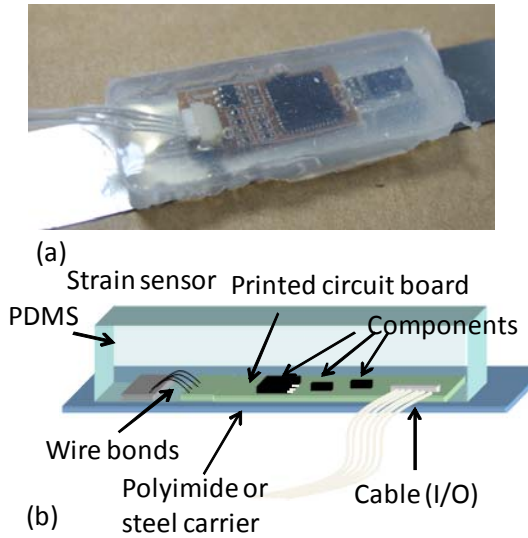

Figure 4. Strain sensing front-end module
 (a) picture of a realization on a steel carrier (b) diagram

The MEMS strain sensor is packaged together with the readout ASIC into a special front-end strain sensing module (Fig. 4) which is to be embedded inside the reinforced concrete onto the reinforcing bar, preferably prior to the pouring of the concrete. The sensor is mounted on a polyimide or steel carrier which in turn is glued (or in case of steel, could also be welded) onto the reinforcing bar. The module is molded in PDMS silicone to protect the components from the environment during installation and pouring of concrete, while remaining a mechanically compliant package to avoid distorting the strain sensor measurement. This front-end strain sensing module is connected to the rest of the module with a small 4-wire cable with a maximum length of 1.5m.

The use of custom-developed MEMS sensors and read-out ASIC allows to meet the specific requirements of the building monitoring application and differentiates the presented system from the earlier prototype system presented in [6] and [7].

C. Measurement initiation and radio polling

1) Accelerometer modules

The main trigger for the recording of an acceleration measurement is the detection of the start of an earthquake. The detection can happen in two ways:

a) The output of the built-in accelerometer in a selected number of monitoring nodes exceeds a certain minimum threshold, during a certain minimum time; these monitoring nodes alert the base station which will decide whether to wake up the entire network of acceleration sensing nodes over the radio. The monitoring nodes are selected based on their location and amount of environmental noise; ground-level nodes may be suitable candidates, provided they are sufficiently far removed from disturbance sources such as heavy traffic. The selection of monitoring nodes can be done dynamically from the base station. This allows for example to disable the monitoring function on nodes that report

unusually high numbers of false alarms. To that purpose, the hardware and software of the monitoring nodes are identical to that of the non-monitoring nodes. The monitoring function is an optional function which can be enabled or disabled during operation by the base station.

b) An external source of earthquake detection can be coupled to the base station, which can use such information in addition to possible information from monitoring nodes to decide whether to wake up the entire network or not.

In both of these cases the wake-up of (most of) the acceleration sensing nodes to initiate measurement has to be done over the radio link. This also implies that it is possible to wake up the nodes via the base station over the radio link at any chosen time independent of the presence of an earthquake, which is a desired functionality for testability and monitoring of the system. It also means that all modules in the network will be woken up during a detected event, even if the accelerations locally at some modules have not (yet) reached a value exceeding the trigger threshold.

It is required to be able to record the early onset of an earthquake event, even before and certainly no later than 1 ms after it reaches a pre-set trigger threshold. In order to do this, the accelerometer is constantly running at 3 x 200Hz sample rate with the measurements recorded in a 54-second loop buffer. This requires an ultra low power sensor and readout. The power consumption of the 3D accelerometer and 3-channel readout operating continuously is 125 μ A at 3V.

The node must be woken up within 54 seconds after the start of the recording of interest to avoid the loop buffer overflowing which would lead to data loss. To respond timely to an event triggered from the base station, the radio polling interval of the accelerometer modules is set to 15 seconds. Once the event trigger is reached the loop buffer contents are preserved and once the buffer is full recording will continue in

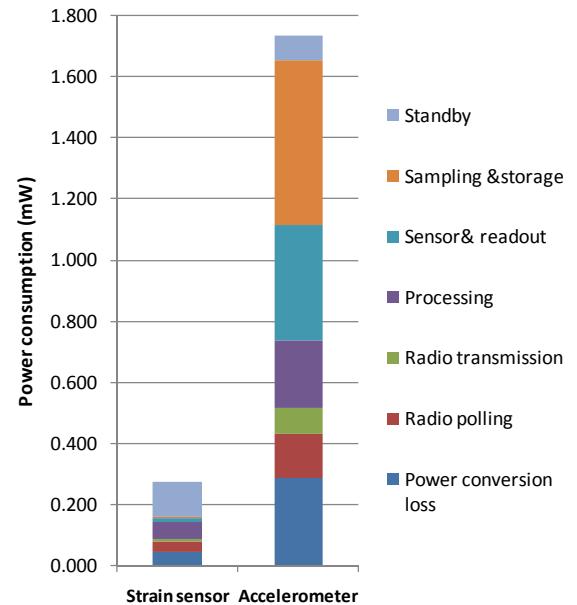

Figure 5. Sensor module power consumption breakdown

a secondary 54-second buffer until the next event trigger.

2) Strain sensor modules

The main measurement scenario for the strain sensor is a periodic readout. Samples are taken at a configurable sample rate between 2 seconds and 18 hours. The strain sensor modules use a radio polling interval of 60 seconds. This also allows manual wake-up functionality from the base station, again useful for monitoring and testability reasons. Unlike for the accelerometers, in the case of the strain sensors the sensor and read-out ASIC can be entirely shut down between measurements. This results in a lower power consumption and longer battery life. Since a typical building requires many more strain sensors than accelerometer modules, it is useful for the strain sensors to have the longest battery service life.

III. RESULTS

A. Power consumption

Fig. 5 shows the breakdown of the power consumption in the sensor modules for strain sensor and accelerometer modules. The total average power consumption is 0.274mW for the strain sensor modules and 1.73mW for the accelerometer modules. With the abovementioned C-cell size battery this implies a battery life of 12 years for the strain sensor modules and 2 years for the accelerometer modules.

B. Laboratory validation

Fig. 6 shows a lab setup on a scale model of the building used to validate the accelerometer modules. For this test, the custom patch antenna was not used, but a standard whip antenna was used instead. The result shows a very good correlation between the reference accelerometers and the proposed wireless modules.

The strain sensor modules were preliminarily validated in a calibration setup and show sensitivities between 10 and 20

$\mu\epsilon/mV$, varying from sensor to sensor.

CONCLUSION

The presented wireless system for building monitoring takes advantage of the unique features of custom-developed MEMS sensors and read-out ASIC combined with an optimized network and module architecture, to realize a solution which offers long battery lifetime and potentially low cost in manufacturing, installation and maintenance, while providing high-quality sensor data at the right time.

REFERENCES

- [1] Pozzi M., D. Zonta, W. Wang and G. Chen. 2010. "A framework for evaluating the impact of structural health monitoring on bridge management". Proc. 5th International Conf. on Bridge Maintenance, Safety and Management (IABMAS2010), Philadelphia, 11-15 Jul 2010.
- [2] Lynch, J.P. and K.J. Loh. 2006. "A summary review of wireless sensors and sensor networks for structural health monitoring." The shock and vibration digest, 38(2):91-128.
- [3] Zonta, D., M. Pozzi, and P. Zanon. 2008. "Managing the Historical Heritage Using Distributed Technologies," International Journal of Architectural Heritage, 2:200-225.
- [4] Kruger, M., C.U. Grosse and P.J. Marron, 2005. "Wireless Structural Health Monitoring Using MEMS", Key Engineering Materials 293-294: 625-634.
- [5] J. Santana, R. van den Hoven, C. van Liempd, M. Colin, N. Saillen, C. Van Hoof, "A 3-axis accelerometer and strain sensor system for building integrity monitoring", Proc. 16th International Conference on Solid-State Sensors, Actuators, Microsystems, Beijing, June 5-9, 2011.
- [6] A. Amditis, Y. Stratakos, D. Bairaktaris, M. Bimpas, S. Camarinopolos, S. Frondistou-Yannas, et al., "An overview of MEMSCON project: an intelligent wireless sensor network for after-earthquake evaluation of concrete buildings", Proc. "14th European Conference on Earthquake Engineering (14ECE)", Ohrid, FYROM, 30 Aug - 03 Sep, 2010.
- [7] A. Amditis, Y. Stratakos, D. Bairaktaris, M. Bimpas, S. Camarinopolos, S. Frondistou-Yannas, et al. "Wireless sensor network for seismic evaluation of concrete buildings", Proc. "5th European Workshop on Structural Health Monitoring (EWSHM 2010)", Sorrento, Italy, 29 Jun - 02 Jul, 2010.

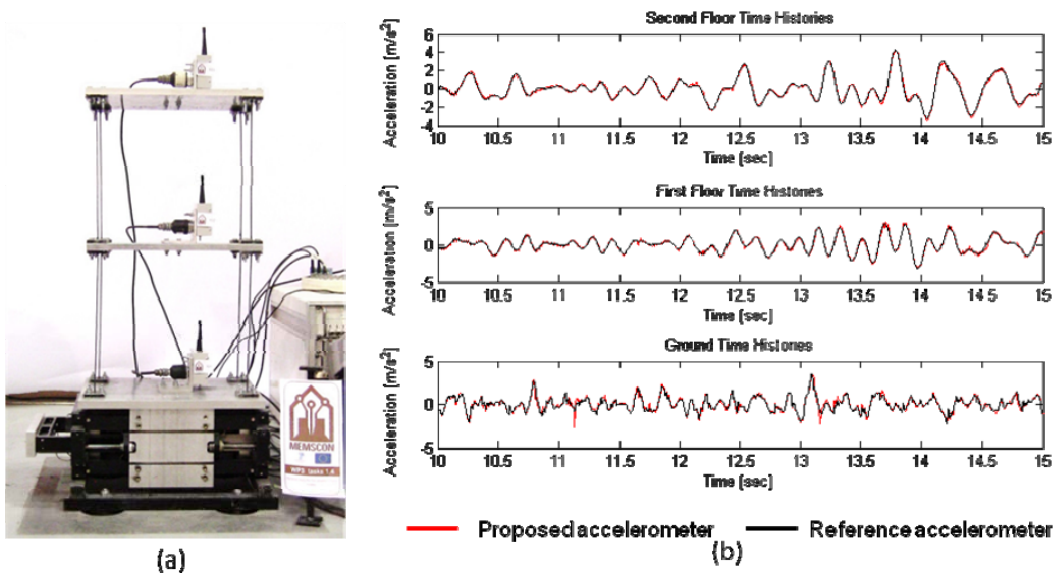

Figure 6. (a) Building scale model in the lab with the wireless accelerometer modules and reference accelerometers installed (b) Evaluation result comparing the proposed wireless accelerometer to the reference accelerometer output