

## Luminescence of multiple modulation-doped GaAs-Al<sub>x</sub>Ga<sub>1-x</sub>As heterojunctions in high magnetic fields

F. Meseguer

*Departamento de Optica y Estructura de la Materia and Instituto de Física del Estado Sólido,  
Universidad Autónoma, 28049 Madrid, Spain*

J. C. Maan

*Max-Planck-Institut für Festkörperforschung, Hochfeldmagnetlabor,  
166X F-38042 Grenoble Cedex, France*

K. Ploog

*Max-Planck-Institut für Festkörperforschung, Heisenbergstrasse 1,  
D-7800 Stuttgart, Federal Republic of Germany*

(Received 15 July 1986; revised manuscript received 8 October 1986)

The luminescence of wide-modulation (500 Å) *n*-doped multiple quantum wells under high magnetic fields (up to 23 T) shows the recombination of the electrons and the holes in the lowest Landau level of the three electronic subbands occupied. The luminescence intensity shows an oscillatory behavior with magnetic field corresponding to the depopulation of successive subbands. At a fixed luminescence frequency, the intensity shows a synchronical behavior with magnetoresistance oscillations when the luminescence energy corresponds to deexcitation of electrons with the Fermi energy.

The optical properties of undoped quantum wells and superlattices have been studied extensively, while in modulation-doped heterostructures mainly transport experiments have been performed.<sup>1</sup>

In magneto-optical experiments of two-dimensional (2D) systems, mainly absorption in the far-infrared (FIR) region<sup>2,3</sup> by inter-Landau-level transitions and magneto-luminescence<sup>4,5</sup> experiments have been reported.

The mechanisms responsible for the behavior of the luminescence in doped quantum wells are only partially understood. It is one of our goals to contribute to the clarification of this matter by studying the magnetoluminescence. Therefore, we report here magnetoluminescence experiments of modulation-doped GaAs-Al<sub>x</sub>Ga<sub>1-x</sub>As multiple quantum wells with large well width. Special interest has been paid to the behavior of the luminescence intensity as a function of the energy at fixed magnetic field. We also report here simultaneous magnetotransport and luminescence oscillations, at fixed energy, while sweeping the magnetic field. The experimental results are analyzed in the frame of the transition probability of recombination of electrons coming from the different subbands occupied and the photoexcited holes at the top of the valence band.

The samples studied here are modulation-doped heterostructures with ten alternating GaAs-Al<sub>x</sub>Ga<sub>1-x</sub>As layers with 500-Å GaAs-layer thickness, an *n*-doped Ga<sub>1-x</sub>Al<sub>x</sub>As layer of 200 Å thick, and an undoped Ga<sub>1-x</sub>Al<sub>x</sub>As spacer layer of 100 Å. The electronic properties of these types of samples are basically that of two weakly coupled heterojunctions. The results shown here are observed with a sample with  $7.5 \times 10^{11}$  cm<sup>-2</sup> electron density per junction and mobility at 4 K of  $\mu = 61.000$  cm<sup>2</sup>/sec V, as measured from magnetotransport measure-

ments. Similar results have been obtained in the other samples. In the luminescence experiments, the samples were mounted in an immersion cryostat at 1.7 K with the magnetic field parallel to the superlattice axis. Photoluminescence was excited with LD-700 dye laser pumped with a Kr<sup>+</sup> laser. The pumping wavelength was kept close to the luminescence emission in order to avoid electron heating by the laser.<sup>6,7</sup> Negligible differences were found in the Shubnikov-de Haas oscillations in darkness, and when the laser was shining on the sample with a power density of  $\sim 0.1$  W/cm<sup>2</sup> at energies a few tens of millielectron-volts above the luminescence frequency. We also measured the Raman scattering of a 2D plasma<sup>6</sup> in a back-scattering configuration with the K vector of the light parallel to the superlattice axis. We used the red lines of a Kr<sup>+</sup> laser, and the scattered light of the sample at 4 K was detected with a Jarrell-Ash double monochromator and a photon-counting system.

Figure 1 shows the luminescence profile for different magnetic fields. At zero magnetic field the luminescence shows a single peak at 1518 meV. This energy is slightly smaller than that of the bulk band gap GaAs luminescence (1519 meV). The width of the luminescence is much less (2.2 meV) than that reported by Pinczuk and co-workers<sup>8,9</sup> and Worlock *et al.*<sup>10</sup> ( $\sim 20$  meV) in GaAs-Al<sub>x</sub>Ga<sub>1-x</sub>As 2D electron systems with narrower wells, which we attribute to the heterojunction character of our sample, as we will discuss later. The results of luminescence intensity as a function of the fixed magnetic field can be summarized as follows (see Figs. 1 and 2). From  $B = 0$  to 6 T the luminescence linewidth becomes narrow, its maximum intensity increases, and its position shifts to higher energies. Above 6 T a new peak appears at 5.5 meV at a lower energy than the previous one, which in-

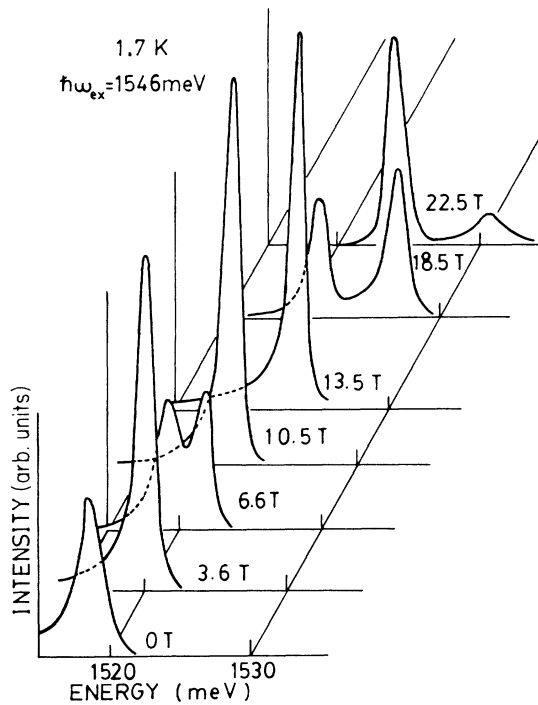

FIG. 1. Luminescence spectra of modulation-doped GaAs- $\text{Al}_x\text{Ga}_{1-x}\text{As}$  multiple quantum wells for different magnetic fields.

creases in intensity and has the same field dependence as the former peak. This former peak decreases in intensity for  $B > 4$  T and disappears at 8 T. At  $B = 16$  T the same phenomenon is observed with another new peak, this time at 12 meV lower energy than the first one. The integrated luminescence intensity remains roughly constant, independent of the magnetic field.

Figure 2 shows the energy position (lower part) and intensity of luminescence (upper part) as a function of the magnetic field. The three sets of points can be described by straight lines of slope 0.85 meV/T and which interception with the energy axis at  $B = 0$  T is 1517, 1511.5, and 1505 meV, respectively. However, no luminescence peaks at these energies below the gap have been observed at zero magnetic field. We interpret the magnetoluminescence peaks as being due to the recombination of electrons coming from the lowest Landau levels of the electronic subbands which are separated in energy by  $E_2 - E_1 = 1517 - 1511.5 = 5.5$  meV and  $E_2 - E_0 = 1517 - 1505 = 12$  meV. These energy differences are in good agreement with the results of the intersubband Raman scattering<sup>6</sup> which showed maxima at energy shifts of 5 and 11 meV. Note that these experimental results are surprising because we observe luminescence at the fundamental energy gap, despite the fact that we seem to observe a significant quantization of energy levels, due to confinement, which would lead to states at energies higher than the gap. Electron acceptor recombination is rejected because at zero magnetic field only a single peak has been found, and none below it.

Figure 3 shows simultaneous magnetoresistance and

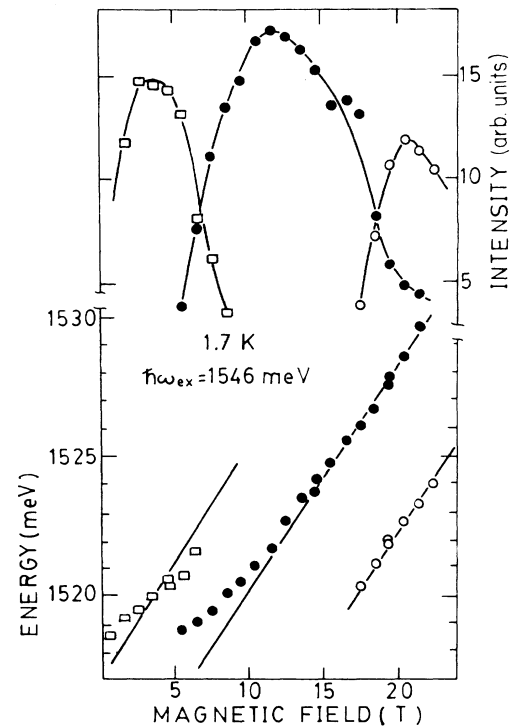

FIG. 2. Luminescence energies (lower part) and intensities (upper part) of the transitions shown in Fig. 1 as the function of the magnetic field.

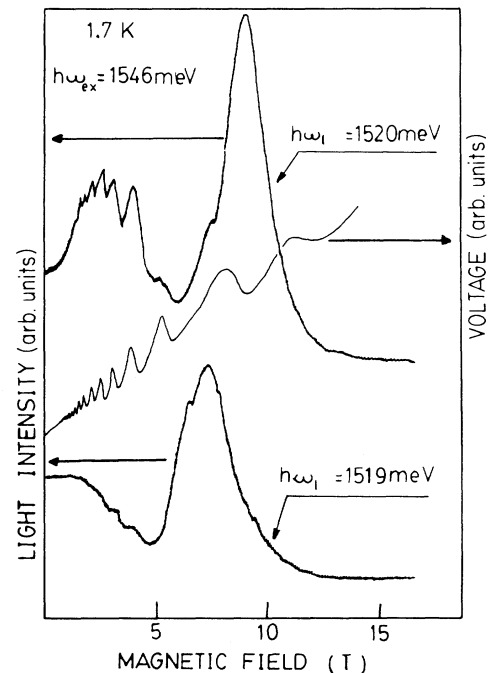

FIG. 3. Magnetoresistance and oscillations of the luminescence intensity at a fixed energy as a function of the magnetic field for different luminescence frequencies. Note the synchronicity in the oscillations between these two experiments at  $h\nu_l = 1520$  meV.

luminescence intensity measurements at a fixed energy as a function of magnetic field. The luminescence shows for low-magnetic-field oscillations similar to the magnetoresistance oscillations. However, only when the luminescence energy is tuned at  $\hbar\omega_l = 1520$  meV, the luminescence oscillations behave synchronically with those of the magnetoresistance and their amplitude is maximal. When luminescence energy is tuned 1 meV below or above (not shown in Fig. 3)  $\hbar\omega_l = 1520$  meV, the oscillations of light intensity smear out, and the synchronism with magnetoresistance is lost. This synchronicity does not depend essentially on the excitation energy. However, at excitation energies far above the gap, the amplitude of the luminescence oscillations decreases, probably due to electron heating. Smith, Petrou, Perry, and Worlock<sup>5</sup> have also observed oscillations in the luminescence from GaAs-Al<sub>x</sub>Ga<sub>1-x</sub>As samples, but without the synchronical behavior with the magnetotransport measurements reported here.

In order to explain the results obtained we assume that the photoexcited electrons relax rapidly to the Fermi energy and the photoexcited holes relax rapidly to the top of the valence band. At zero field the Fermi energy lies slightly higher than subband  $E_2$  (see Fig. 4), and we consider the recombination of carriers from  $E_2$  to the valence band. Schematically, one can distinguish three possible

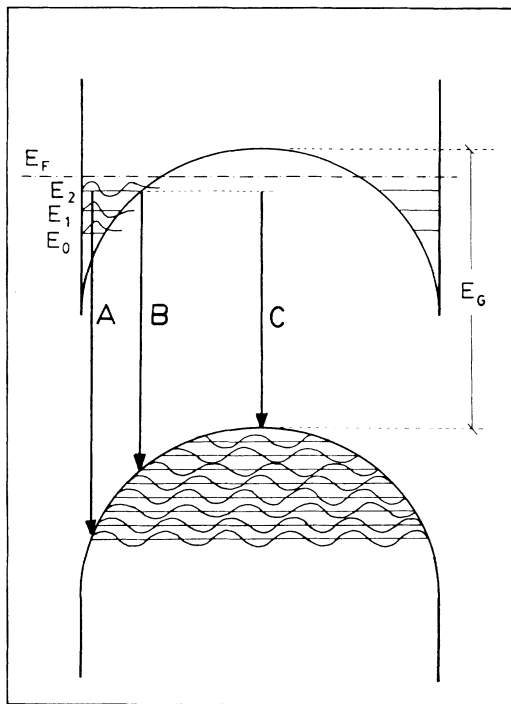

FIG. 4. Schematic band structure and wave function for a modulation-doped heterostructure of 500-Å GaAs thickness. The arrows A, B, and C denote different types of recombination processes as discussed in the text.  $E_G$  is the band-gap energy.  $E_F$  is the Fermi energy, taken as origin of energies.  $E_2 = -3$  meV,  $E_1 = -8.5$  meV, and  $E_0 = -15$  meV are the three subbands obtained from the results (see text).

processes to recombine with valence-band states, at different energies, indicated as A, B, and C in Fig. 4. The luminescence intensity is proportional to the wave-function overlap integral which determines the transition-matrix element and to the occupation of the initial and the final states. In process A, whose energy corresponds to  $E_G + E_2$ , the overlap integral is large but the population of photoexcited holes is small. To the contrary, in process C, whose transition energy is below the gap due to the Franz-Keldish effect,<sup>11</sup> the overlap integral is small but the population of photoexcited holes is large. The real process should be like B, near the gap, that is a compromise between a high overlap integral and a large population of photoexcited holes. This process should be more probable for electronic states whose wave functions are more extended toward the center of the well, i.e., the optical recombination from  $E_2$  is more probable than from  $E_1$ , and from  $E_1$  more probable than from  $E_0$ . Consequently, the heterojunction character of our samples would lead to luminescence near the gap. This effect should depend on the well width. For narrow wells like those used in Refs. 8, 9, and 10, the effect of the electric field in the interfaces is much less important than in our case. Therefore, the electrons and photoexcited holes are not so spacially separated and, as observed, the luminescence band would cover the energy range from  $E_G$  to  $E_G + E_F$ .

The magnetic field splits the subbands into Landau levels, but does not affect the wave function in the  $z$  direction. Therefore, the argument of the overlap integral along the  $z$  direction also stands here. As the magnetic field increases, luminescence is allowed for  $\Delta n = 0$  transition between Landau levels of electrons and holes, but thermalization makes more probable the recombination of electronic states in the lowest Landau levels ( $n = 0$ ). However, the magnetic field also changes the Fermi energy and depopulates successive Landau levels. Therefore, as the magnetic field is increased the Landau levels of  $E_2$  subband would be emptied, and then the most probable luminescence comes from the recombination of the lowest Landau level of the  $E_1$  subband due to the overlap-integral argument stated above (see Fig. 4). At even higher magnetic fields the same process is repeated for the  $E_0$  subband. In order to prove this argument we have done a simple calculation of the variation of the Fermi energy with magnetic field for three subbands occupied like that in Fig. 4. The carrier concentration has been taken as  $7.7 \times 10^{11} \text{ cm}^{-2}$  per junction and the separation between subbands were  $E_2 - E_1 = 5.5$  meV and  $E_1 - E_0 = 6.2$  meV. As expected, and as proof of confidence, the calculation shows that oscillations of the Fermi energy agree with those of Shubnikov-de Haas measurements. This calculation also shows that at  $B = 7$  T the Fermi energy changes from the lowest Landau level of the  $E_2$  to the lowest Landau level of the  $E_1$  subband. Therefore at 7 T a quenching of the luminescence coming from the recombination of electrons at  $n = 0$  Landau level of  $E_2$  subband is expected. This effect has been observed as shown in Fig. 2 together with the simultaneous onset of the luminescence coming from the recombination of the electron at the lowest Landau level of  $E_1$ . At  $B = 17$  T the calculation shows again the depopulation of the lowest Landau level of the  $E_1$  subband that is consistent with the in-

tensity measurements observed in Fig. 2. It is important to stress that there is internal consistency between all experimental results [the total carrier density, the relative energy of the subbands, and the fields at which the subbands are emptied, determined optically and with resistance maxima in the Shubnikov-de Haas (SdH) oscillations] as verified by calculation of the Fermi energy described above. The consistency of experimental results precludes other explanations involving impurities, inhomogeneities, and the like. Finally, within our analysis of the data it is immediately understandable that we observe only synchronism between the intensity variation at fixed energy as a function of the magnetic field and the magnetoresistance when we tune the spectrometer at 1520 meV. This energy corresponds to the recombination of electrons from the Fermi energy and, therefore, the synchronicity with the SdH oscillations is not surprising. However, this luminescence is observed close to the fundamental gap despite the fact that  $E_F$  lies at least 15 meV above the lowest subband as obtained by the periodicity of the SdH oscillations.

In conclusion, we believe we have given a comprehensive explanation for the apparently contradictory results, that

the luminescence in wide-doped quantum wells is observed at energies near  $E_G$  and not at  $E_G$  plus the subband energy. Our mechanism provides a natural explanation for this effect based entirely on the one-electron theory and without recurrence to band-gap renormalization due to many-body effects. Our results indicate clearly the importance of the strong electric field responsible for the band bending in doped heterostructures and may contribute toward a better understanding of the results of this type of experiments. Furthermore, it is possible to obtain information about subbands energies and their occupation through optical experiments in such a way that magnetoluminescence may be a complementary method in the more usual magnetotransport studies.

These experiments were performed at the Hochfeldmagnetlabor des Max-Planck-Institut in Grenoble. One of us (F.M.) acknowledges the hospitality and assistance received from the High Magnet Laboratory staff and especially thanks Professor P. Wyder for enthusiastic encouragement and M. Krath for the excellent technical assistance.

<sup>1</sup>See, for instance, *Proceedings of the Twelfth Yamada Conference on Modulated Semiconductor Structures (Second International Conference)*, Kyoto, Japan, 1985, edited by Harry C. Gatos [Surf. Sci. **174**, Nos. 1-3 (1986)]; *Proceedings of the Two-Dimensional Semiconductor Conference*, Kyoto, Japan, 1985 (unpublished).

<sup>2</sup>Th. Englert, J. C. Maan, Ch. Uihlein, D. C. Tsui, and A. C. Gossard, *Solid State Commun.* **46**, 545 (1983).

<sup>3</sup>Z. Schlesinger, J. C. M. Hwang, and S. J. Allen, Jr., *Phys. Rev. Lett.* **50**, 2098 (1983).

<sup>4</sup>M. C. Smith, A. Petrou, C. H. Perry, J. M. Worlock, and R. L. Aggarwal, in *Proceedings of the Seventeenth International Conference on the Physics of Semiconductors, San Francisco, 1984*, edited by D. J. Chadi and W. A. Harrison (Springer-Verlag, New York, 1985).

<sup>5</sup>M. C. Smith, A. Petrou, C. H. Perry, and J. M. Worlock, *Surf.*

*Sci.* **174**, 136 (1986).

<sup>6</sup>G. Abstreiter, M. Cardona, and A. Pinczuk, in *Light Scattering in Solids IV*, Topics in Applied Physics, Vol. 54, edited by M. Cardona and G. Güntherodt (Springer-Verlag, New York, 1984).

<sup>7</sup>R. Ulbrich, *Phys. Rev. B* **8**, 5719 (1973).

<sup>8</sup>A. Pinczuk, J. Shah, H. L. Störmer, R. C. Miller, A. C. Gossard, and W. Wiegmann, *Surf. Sci.* **142**, 492 (1984).

<sup>9</sup>A. Pinczuk, J. Shah, R. C. Miller, A. C. Gossard, and W. Wiegmann, *Solid State Commun.* **50**, 735 (1984).

<sup>10</sup>J. M. Worlock, A. C. Maciel, A. Petrou, C. H. Perry, R. L. Aggarwal, M. Smith, A. C. Gossard, and W. Wiegmann, *Surf. Sci.* **142**, 486 (1984).

<sup>11</sup>D. A. B. Miller, D. S. Chemla, and S. Schmitt-Rink, *Phys. Rev. B* **33**, 6976 (1986).