

Lynx Mission Concept Status

Jessica A. Gaskin (NASA MSFC)



Presented on behalf of the Lynx Team

Community STDT

F. Özel, Arizona (Co-Chair)

A. Vikhlinin, SAO (Co-Chair)

S. Allen, Stanford

M. Bautz, MIT

W. N. Brandt, Penn State

J. Bregman, Michigan

M. Donahue, MSU

J. Gaskin, MSFC (Study Sci.)

Z. Haiman, Columbia

R. Hickox, Dartmouth

T. Jeltema, UCSC

J. Kollmeier, OCIW

A. Kravtsov, U. Chicago

L. Lopez, Ohio State

R. Osten, STScI

F. Paerels, Columbia

D. Pooley, Trinity

A. Ptak, GSFC

E. Quataert, Berkeley

C. Reynolds, UMD

D. Stern, JPL

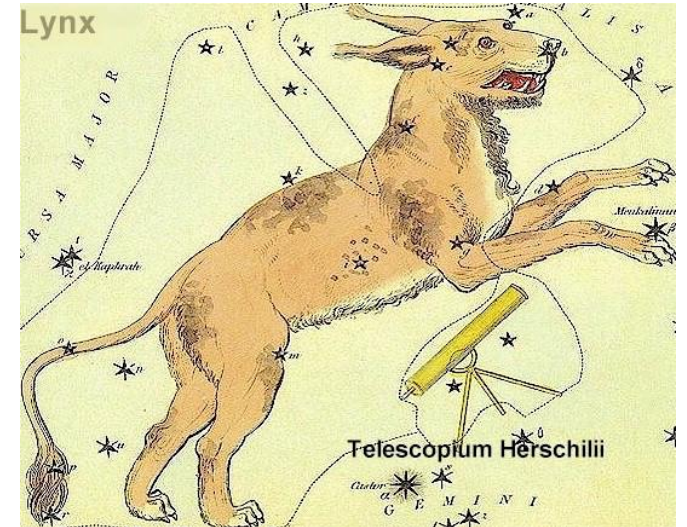

- ❖ A symbol of great insight with the ability to see through solid objects to **reveal the true nature of things.**
- ❖ Much of the baryonic matter and the settings of the most active energy release in the Universe are visible primarily or exclusively in the X-rays

Lynx and the Concept Study

The *Lynx* X-Ray Observatory

- × 50 higher throughput while maintaining *Chandra's* angular resolution.
- × 16 larger solid angle for sub-arcsec imaging
- × 800 higher survey speed at the *Chandra* Deep Field limit
- × ~1000 more power in grating spectroscopy
- High-resolution, spatially resolved spectroscopy on fine scales

Astro2020 Decadal Study Output:

1. A **science case** for the mission
2. A **notional mission** and observatory, including a report on any tradeoff analyses
3. A **design reference mission**, including strawman payload trade studies.
4. A **technology assessment** including: current status, roadmap for maturation & resources
5. A **cost assessment** and listing of the top technical risks to delivering the science capabilities
6. A **top level schedule** including a notional launch date and top schedule risks.

The Dawn of Black Holes

Lynx will observe the birth of the first seed black holes at redshift up to 10 and provide a census of the massive black hole population in the local and distant universe, follow their growth and assembly across cosmic time, and measure the impact of their energy input on all scales. Of interest to all astronomers working on the early universe, galaxy formation, black holes.

Simulated 2x2 arcmin deep fields

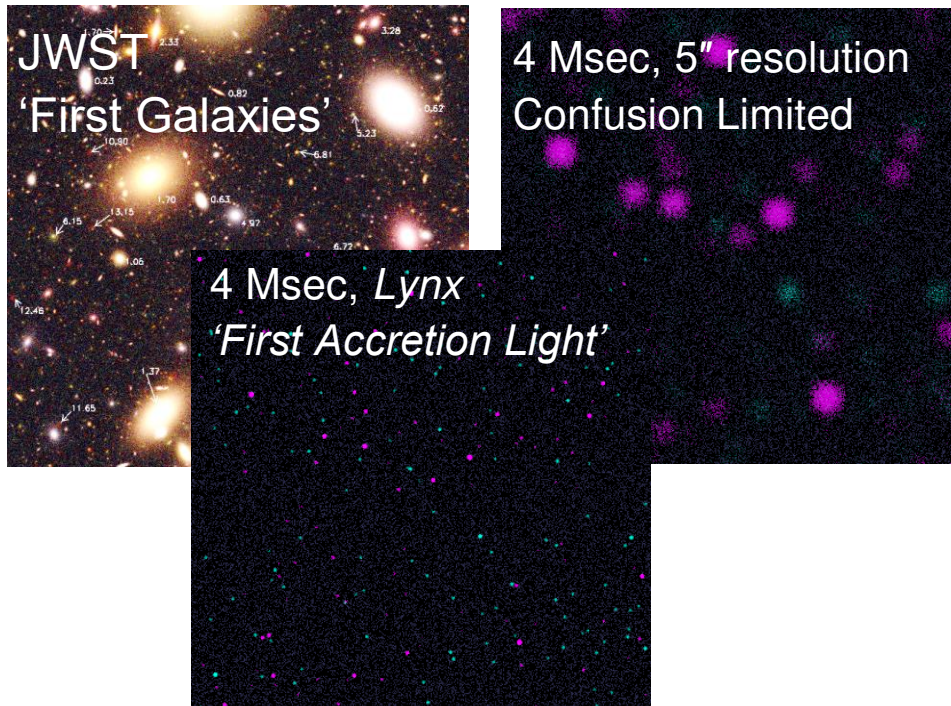

The Invisible Drivers Behind Galaxy Formation and Evolution

The assembly, growth, and the state of visible matter in the cosmic structures is largely driven by violent processes that produce energy that heats the gas in the CGM and IGM. The exquisite spectral and angular resolution of *Lynx* will make it a unique instrument for mapping the hot gas around galaxies and in the Cosmic Web.

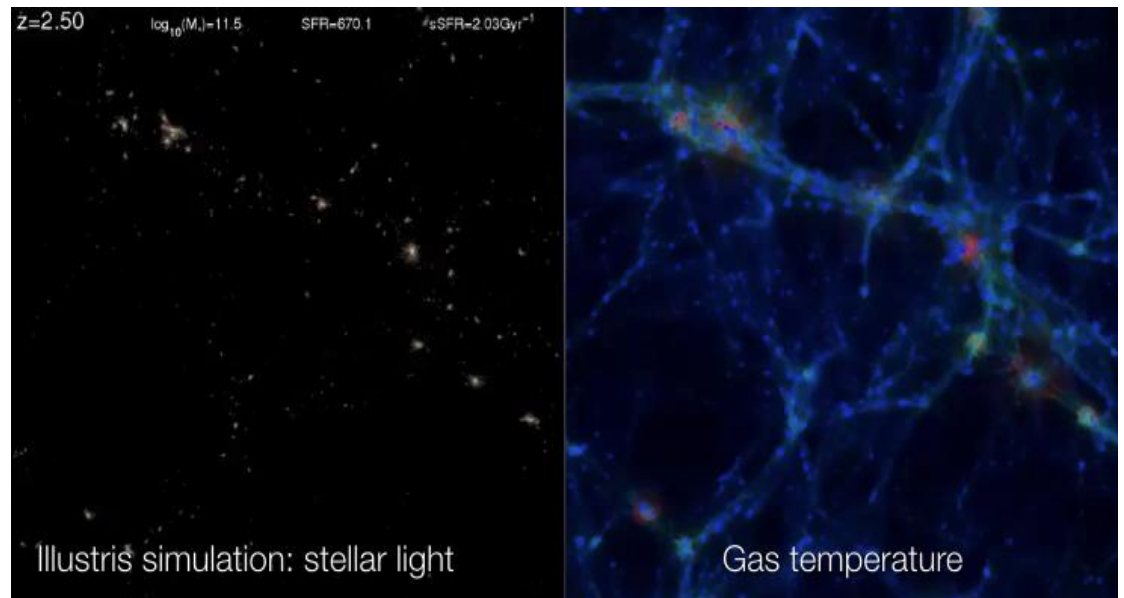

Facility Class Science

Exploration Science with a Rich Community-Driven Observer Program!

- First Black Holes and their Co-evolution with Galaxies
- Cycles of (Hot) Baryons in and out of Galaxies
- Feedback from Stars, Supernovae, and Black Holes
- Origin and Evolution of Stars and their Local Environments
- X-ray Counterparts of GW Events and Multi-Wavelength Phenomena
- Physics of Accretion and Compact Objects

Lynx Optical Assembly

High-resolution X-ray Optical Assembly: 3 Viable Architectures – Trade Study

- Meta-Shell Si Optics (W. Zhang/GSFC)
- Adjustable Optics (P. Reid/SAO)
- Full Shell (K. Kilaru/USRA, G. Pareschi (Brera))

OWG will make a formal recommendation to STDT: 6/1/18
STDT Finalizes their decision: 7/1/18

Up-select will be based on Science, Technical and Programmatic criteria (TBF)

- *Does the configuration Satisfy Science Requirements?*
- *Is there a feasible path for development?*
- *Are there existing X-ray measurements and/or analyses?*
- *Can it interface with the spacecraft and survive launch?*

Science Driven Requirements

Lynx Optical Assembly

Angular resolution (on-axis)	0.5 arcsec” HPD (or better)
Effective area @ 1 keV	2 m ² (met with 3-m OD)
Off-axis PSF (grasp), A*(FOV for HPD < 1 arcsec)	≥ 2 m ² * 300 arcmin ²
Wide FOV sub-arcsec Imaging	10 arcmin radius

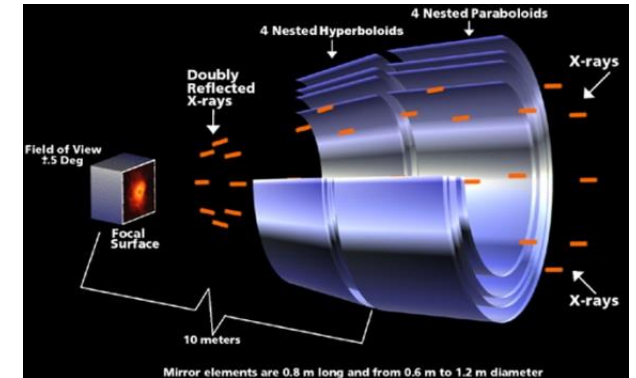
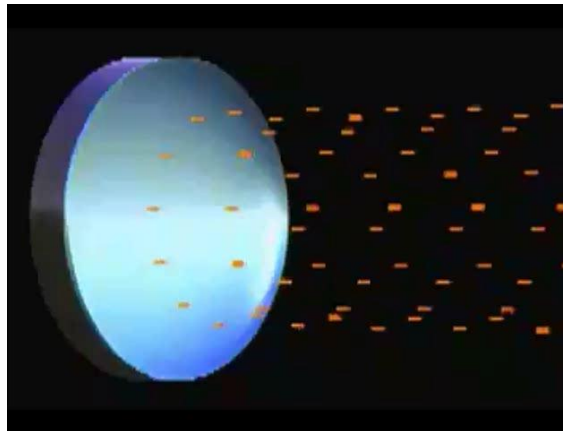

CXC/D. Berry

Meta-Shell Approach

(Zhang et al. NASA/GSFC)



Component	Predicted Contribution to HPD (")	
	Lynx Rqrmnt	Status
Mirror segments	0.2	2.0
Alignment	0.1	1.5
Bonding	0.1	0.5
Thermal	0.2	0.2
Gravity release	0.1	0.1
Total	0.3	2.5

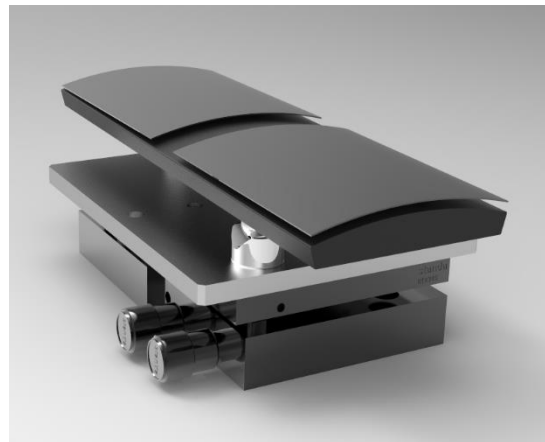

Single-Pair X-ray Test Module

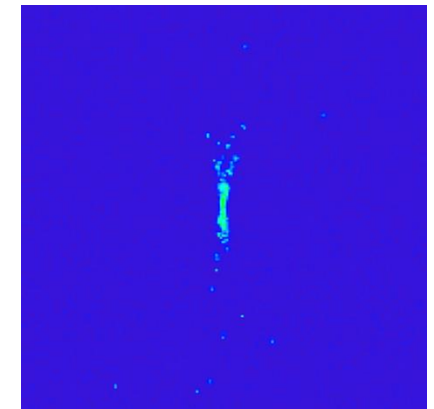

**Full Illumination
4.5keV X-rays
3.8" HPD**

See Talks:

Adjustable Shell Approach

(Reid et al. SAO)

Adjustable X-ray Optics – Quick Intro I



SAO



Schematic X-section

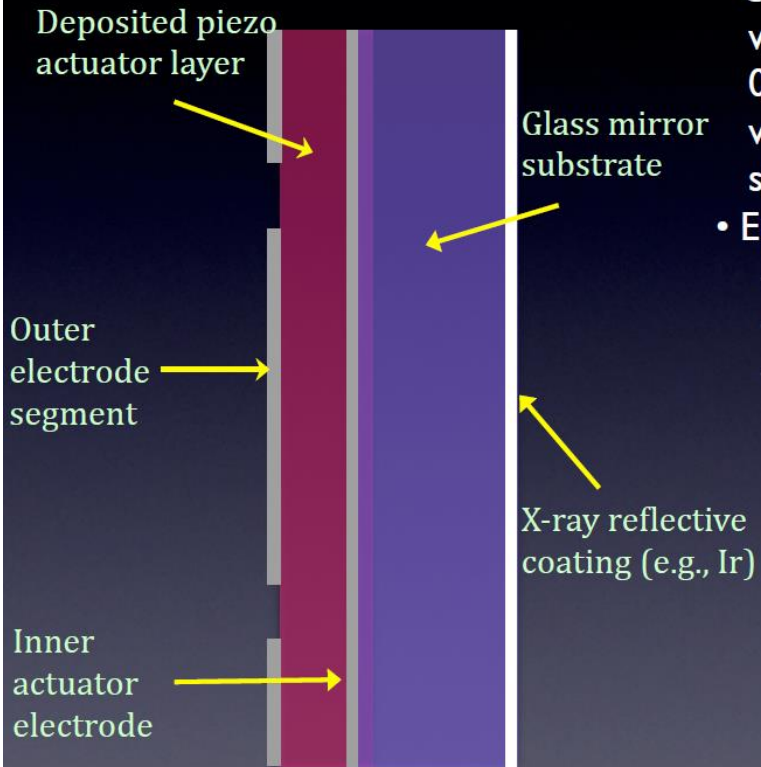

- Continuous, thin film ($1.5 \mu\text{m}$) piezo actuators with independently addressable electrodes on 0.4 mm thick mirror substrate. Low (<10) DC voltage thru piezo thickness produces in-plane stress in piezo, yielding localized bending of mirror.
- Enables efficient correction of mirror figure for:
 - fabrication errors
 - mounting induced distortions
 - *on-orbit* changes due to thermal environment
 - *on-orbit* correction enabled by integral strain gauges directly on piezo cells.

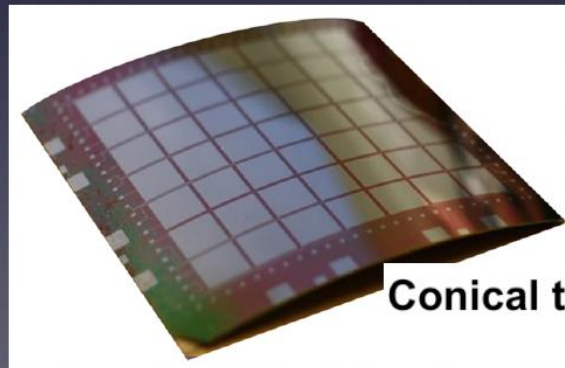

Conical test mirror

Design Parameters:

- Wolter-Schwarzschild
- 3 radial sets of modules (inner, middle, outer) ranging from 200 mm radius to 1500 mm radius
- 292 shells (allowing for space between module rows)
- 42 modules (6 inner, 12 middle, 24 outer)
- ~ 8200 segments (P and S combined)
- Azimuthal spans range from $\sim 200 \text{ mm}$ to $\sim 400 \text{ mm}$
- Axial length 200 mm
- $\sim 10^7$ piezoelectric adjuster cells in total
- Modeled performance $\sim 2.3 \text{ m}^2 @ 1 \text{ keV}$ with Ir coating

See Talks:

Full shell Optical Design

Brera

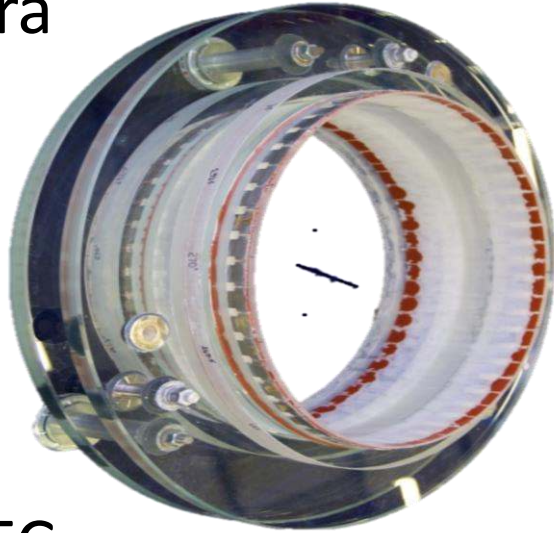

- Fused Silica: low density, low CTE
- Procure high-quality quartz (or, hot slump)
- Fine-grinding to $1.5\mu\text{m}$ OOR (P-V) + polish to 5-6 nm RMS microroughness
- Ion beam figuring corrections
- Coating

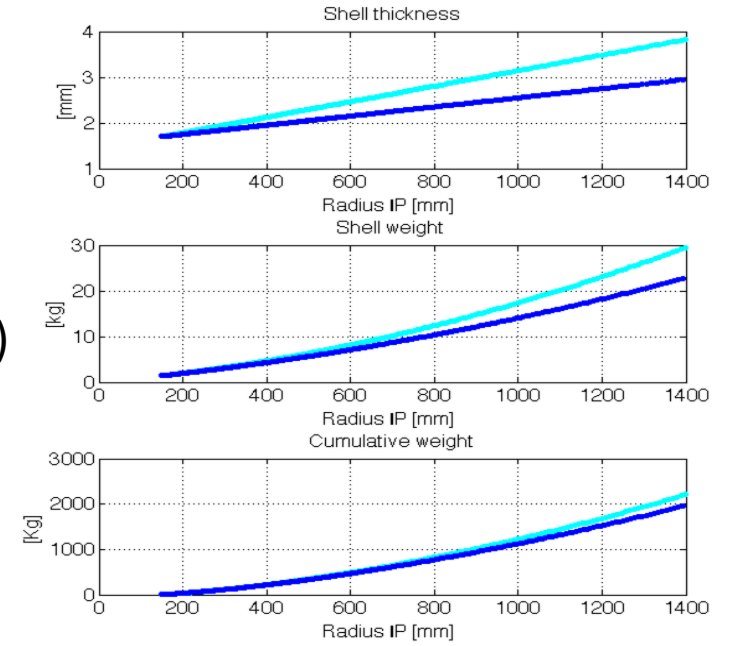

MSFC

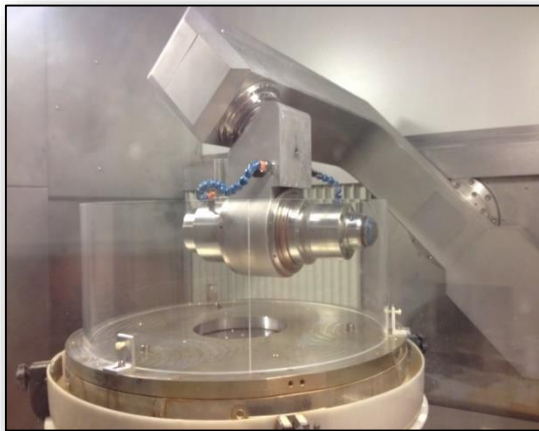

- Be, BeAl: low density, CTE; high modulus, yield strength
- Procure diamond-turned, heat treated, NiP coated shells ($<100\mu\text{m}$ RMS)
- Diamond-turn and Zeeko polish
- Differential deposition corrections

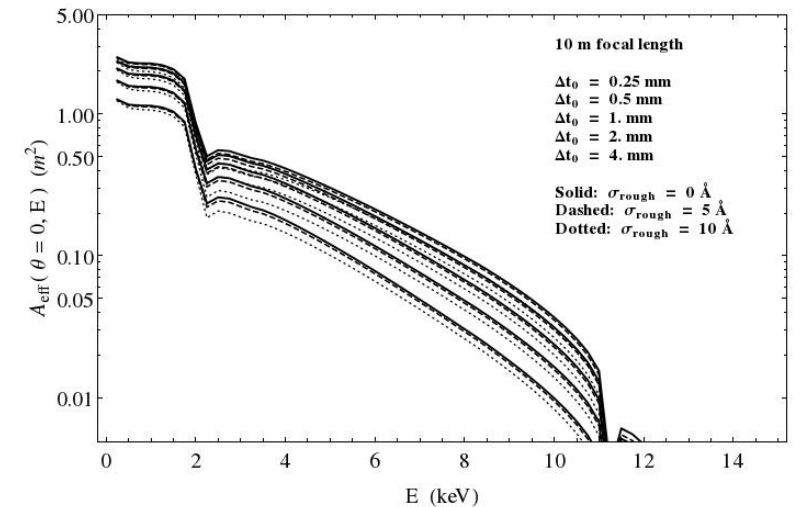

See Talks:

Lynx Optical Assembly

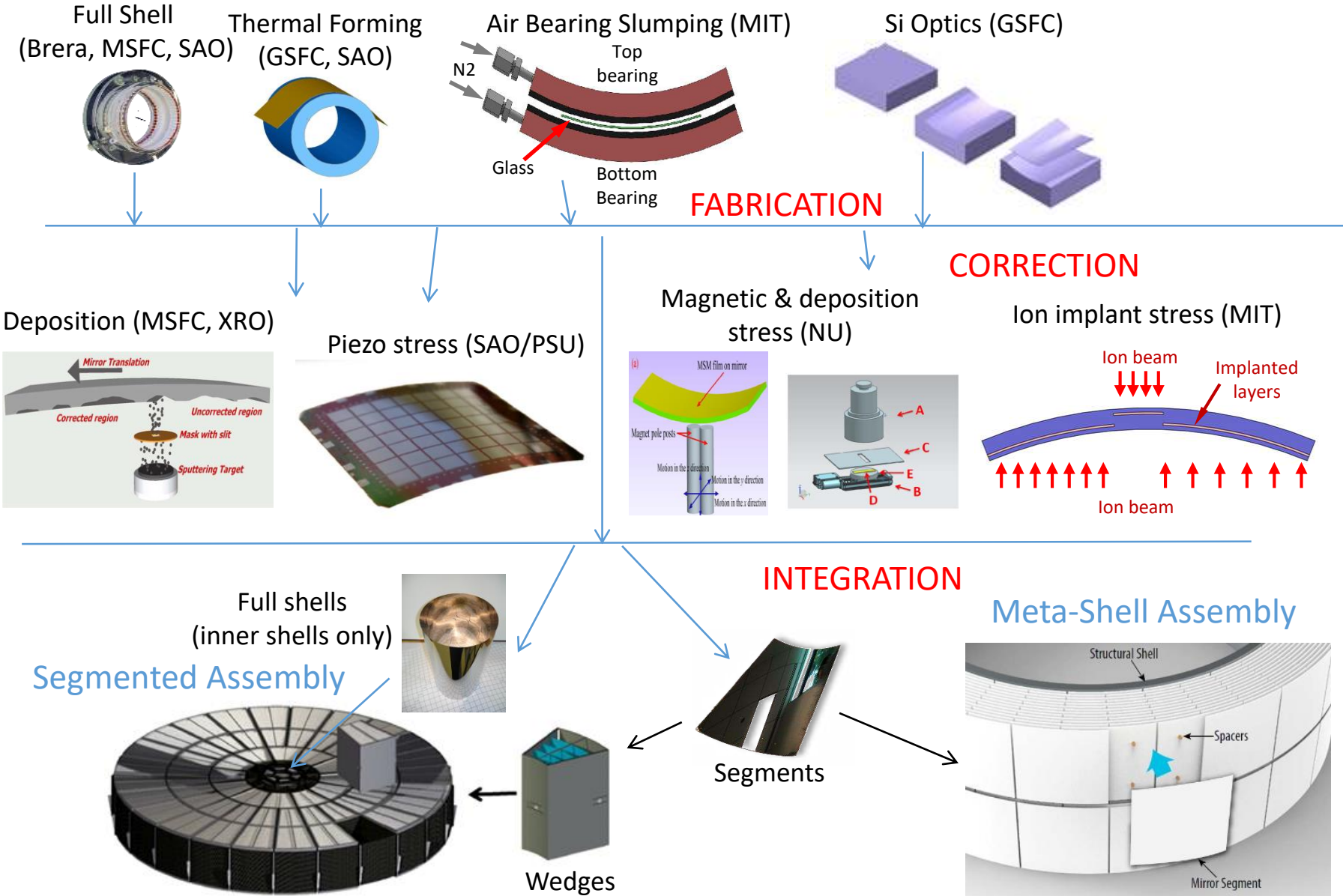

Lynx Science Instruments

- High Definition X-ray Imager (HDXI)

- Instrument Design and Integration (On-going @ MSFC ACO)

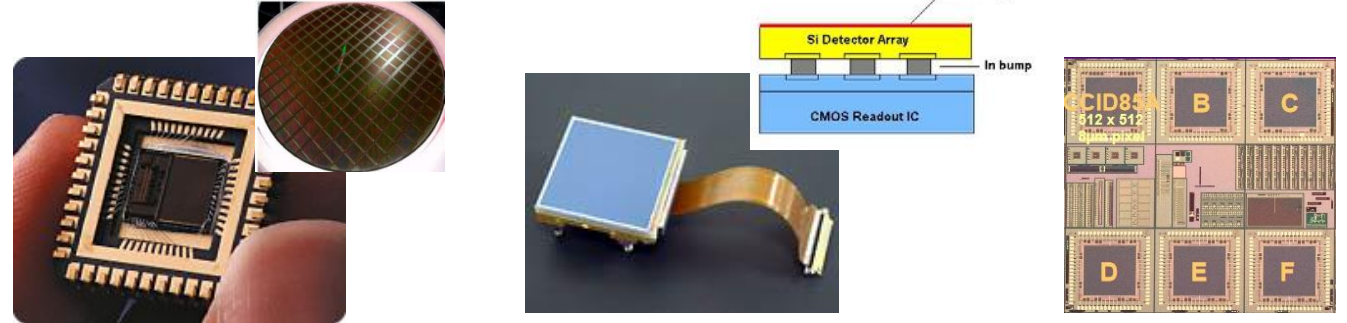

- X-Ray Grating Spectrometer (XGS)

- Instrument Design and Integration (On-going @ MSFC ACO)

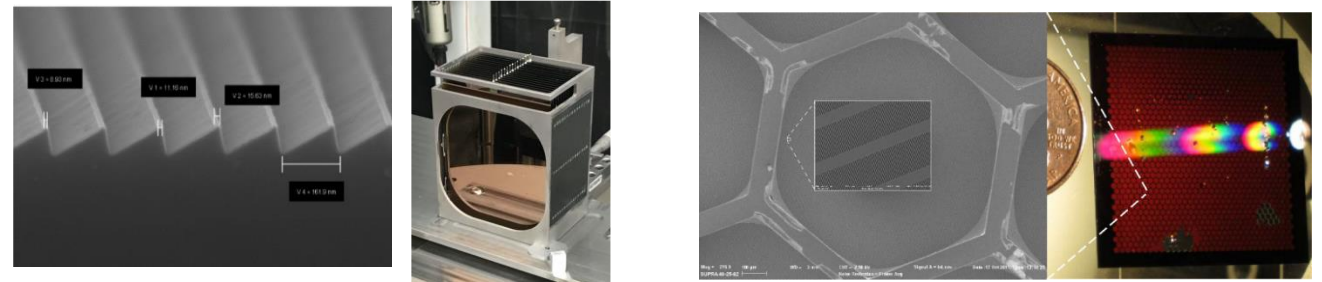

- X-ray Microcalorimeter Imaging Spectrometer (XMIS)

- Instrument Design and Integration (Completed 1st IDL @ GSFC)

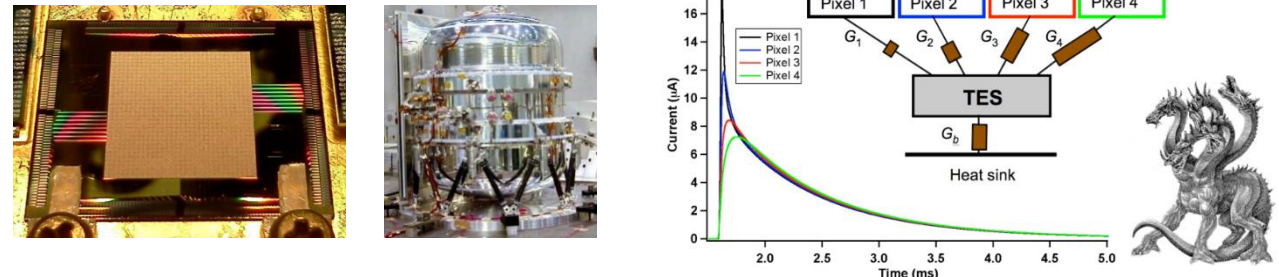

See Talks:

Lynx Science Instruments

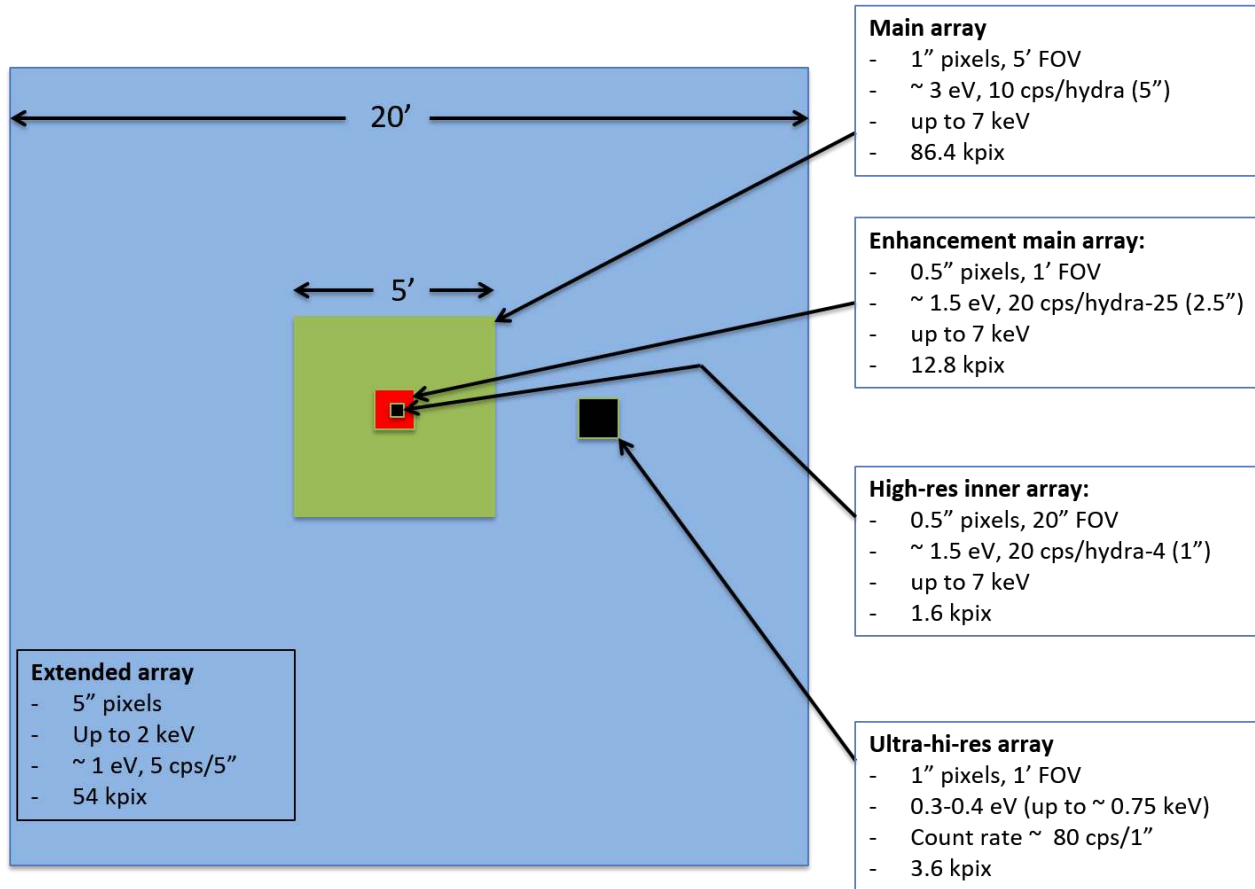

Main array

- 1" pixels, 5' FOV
- ~ 3 eV, 10 cps/hydra (5")
- up to 7 keV
- 86.4 kpix

Enhancement main array:

- 0.5" pixels, 1' FOV
- ~ 1.5 eV, 20 cps/hydra-25 (2.5")
- up to 7 keV
- 12.8 kpix

High-res inner array:

- 0.5" pixels, 20" FOV
- ~ 1.5 eV, 20 cps/hydra-4 (1")
- up to 7 keV
- 1.6 kpix

Ultra-hi-res array

- 1" pixels, 1' FOV
- 0.3-0.4 eV (up to ~ 0.75 keV)
- Count rate ~ 80 cps/1"
- 3.6 kpix

Extended array

- 5" pixels
- Up to 2 keV
- ~ 1 eV, 5 cps/5"
- 54 kpix

High Definition X-ray Imager (Notional)

Energy Range	0.2 – 10 keV QE > 90% (0.3-6 keV), QE > 10% (0.2-9 keV)
FOV	22' x 22' (4k x 4k pixels)
Pixel Size	< 16 x 16 μm (≤ 0.33")
Read Noise	≤ 4 e ⁻
Energy Resolution	37 eV @ 0.3 keV, 120 eV @ 6 keV (FWHM)
Frame Rate	> 100 frames/s (full frame) > 10000 frames/s (windowed region)
Radiation Tolerance	10 yrs at L2

X-ray Grating Spectrometer (Notional)

Effective Area	~4000 cm ² @ 0.3 keV (63% azimuthal coverage)
Resolving Power, R	> 5,000
Energy Resolution	< 5 eV (FWHM)
Count Rate Capability	< 1 count/s/pixel
Array size	300 x 300 pixel array

Lynx X-ray Microcalorimeter (Notional)

Pixel Size	1" (50 μm pixels for 10-m focal length)
FOV	At least 5' x 5'
Energy Resolution	< 5 eV (FWHM)
Count Rate Capability	< 1 count/s/pixel
Array size	300 x 300 pixel array

See Talks:

Mission Design

- *Mission Lifecycle* (Draft)
- *Mission Design* (MSFC ACO) + Trades
 - Structures [Launch vehicle Trade]
 - Thermal
 - Propulsion
 - Avionics [Comm Trade]
 - GNC [Rapid response capability Trade]
 - Power
 - Mechanisms [Moveable optics vs. instrument table Trade]
 - Environments [Orbit Trade]

Model-Based Systems Engineering Approach focused on Concept of Operations

- WBS + dictionary
- Stakeholder Viewpoints
- System Block Diagrams
- System Interface Diagrams (internal and external)
- Use Diagrams
 - Manufacturing
 - AI&T (major sub-systems)
 - Ground Operations
 - Launch Integration
 - Launch Operations (launch, deployment, T&CO)
 - Mission Timeline
 - Science Operations
 - Off-nominal Operations
- Functional Block Diagrams
- System Requirements (Level 1 and 2)

Lynx X-ray Observatory – Notional Mission Lifecycle Schedule

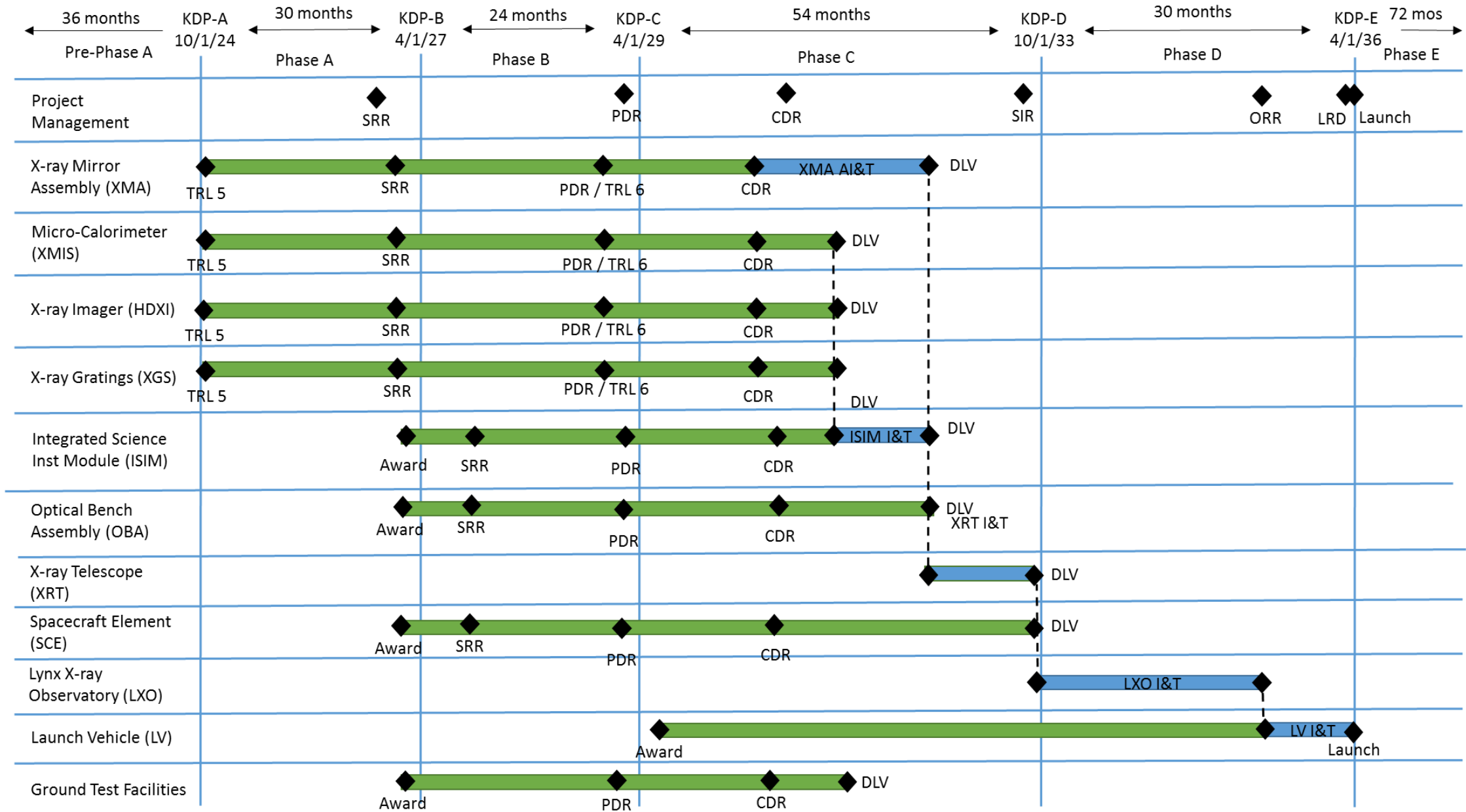

Mission Design

Orbit

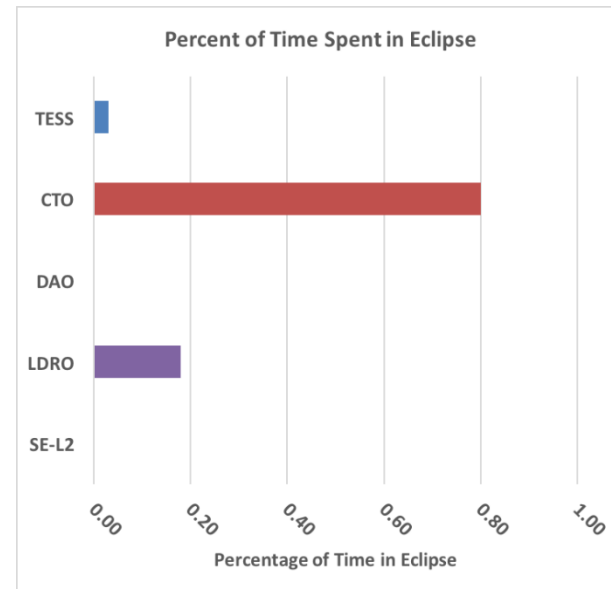
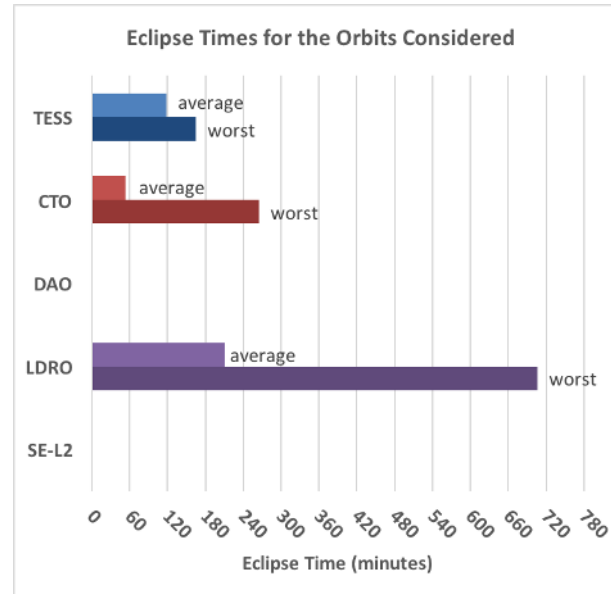
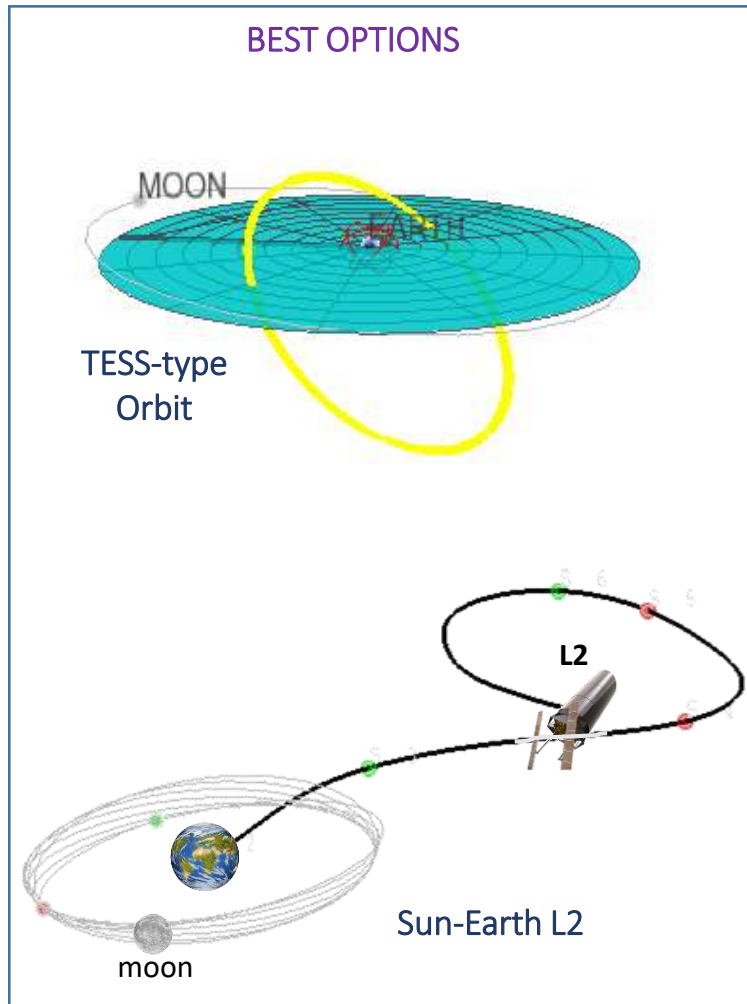

Orbit Trades

- Launch Vehicle (Both)
- Delta-V (SE-L2)
- Thermal Environment (SE-L2)
- Eclipsing (SE-L2, just)
- Communications (TESS)
- Meteroid Environment (Both)
- Radiation Environment (average/worst case – TBD)
- Serviceability (SE-L2)
- Disposal (TESS)
- Station Keeping (TESS)
- Disturbance Environment (Both)

Mission Design

Propulsion

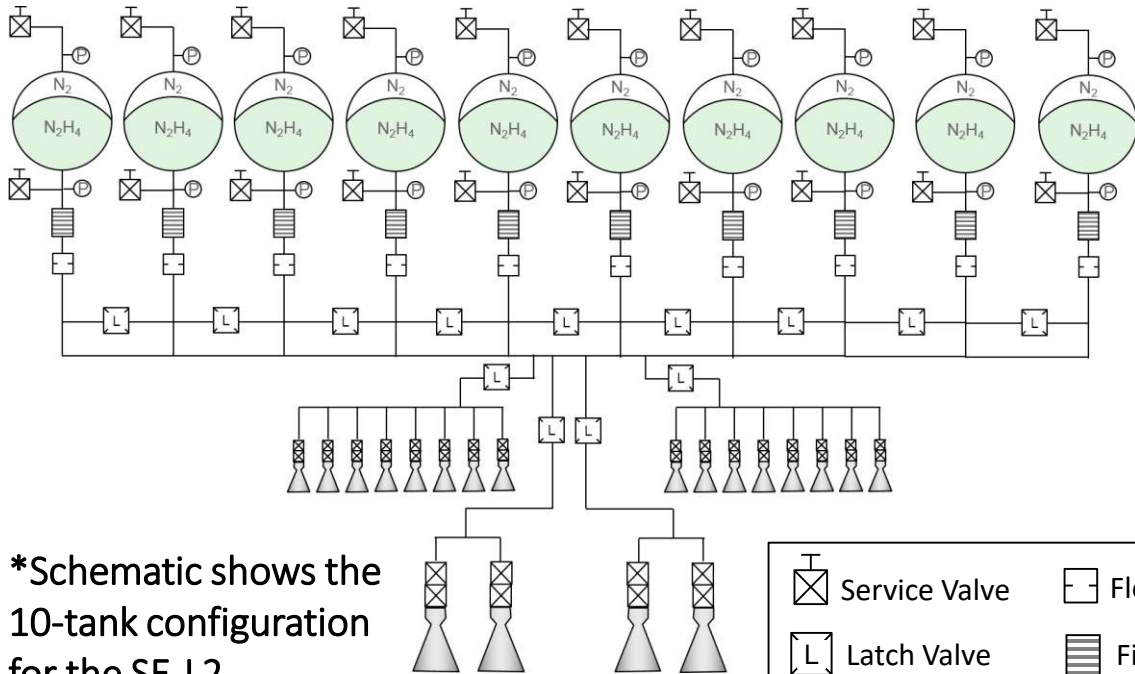

*Schematic shows the 10-tank configuration for the SE-L2 maneuver

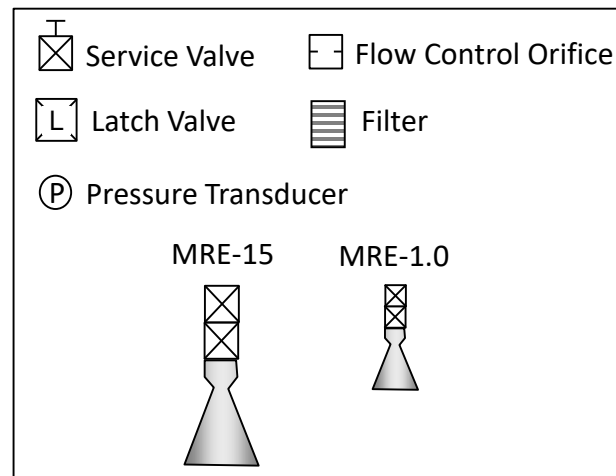

	SE-L2	TESS
Thrust (N)	66	66
Isp (s)	218	218
ΔV (m/s)	215.5	301.7
Propellant Mass (kg) -with 15% Margin-	661.4	907.9
Propellant Volume (in ³)	44,242	60,731
Propellant Tanks Needed	10	13

- Monopropellant blowdown system
Fuel = Hydrazine
Pressurant = Gaseous Nitrogen
- Maneuver assumed: SE-L2
 ΔV required = 215.5 m/s
- Propellant mass for chosen maneuver
Hydrazine = 661.4 kg (includes 5% ACS tax and 10% margin)
- Engines
Main Engines: Northrop Grumman MRE-15
Thrust = 86 N at 27.6 bar, 66 N at 19.0 bar
Isp = 228 s at 19.0 bar
RCS/ACS Engines: Northrop Grumman MRE-1.0
Thrust = 5.0 N at 27.6 bar, 3.4 N at 19.0 bar
Isp = 218 s at 19.0 bar
- Mass estimated using flight-qualified components
Rough estimate made for feedlines and mounts/fittings

Mission Design

Mechanical

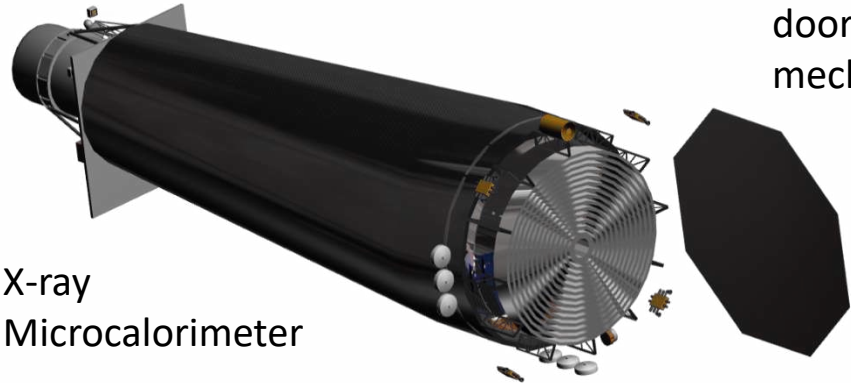

X-ray Microcalorimeter

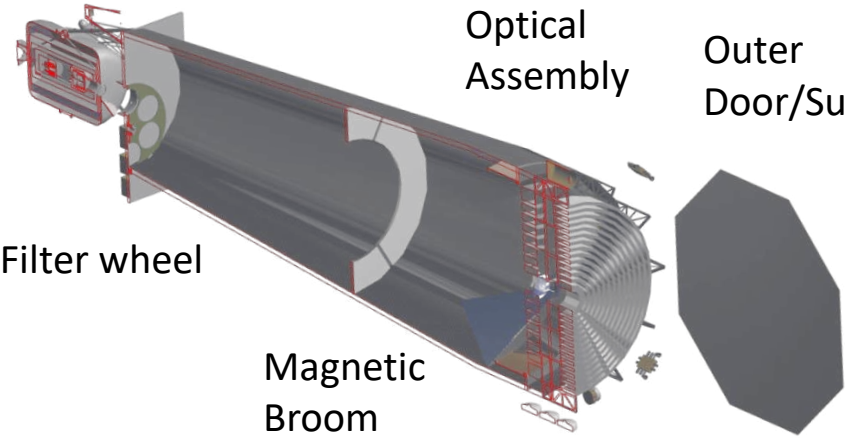

Filter wheel

Magnetic Broom

Optical Assembly

Outer Door/Sunshade

Internal contamination door & gratings mechanisms

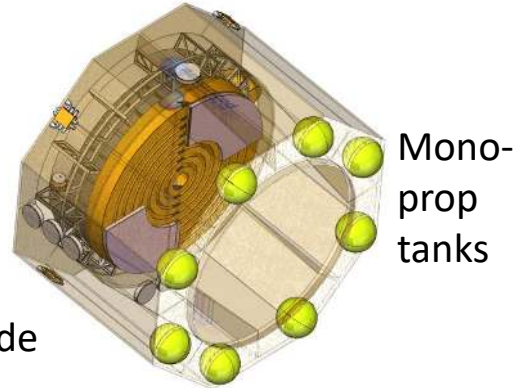
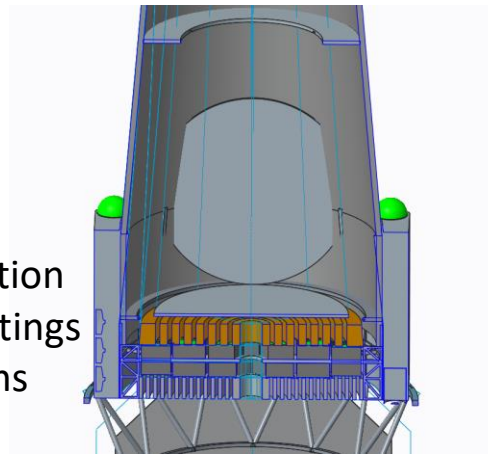

Mono-prop tanks

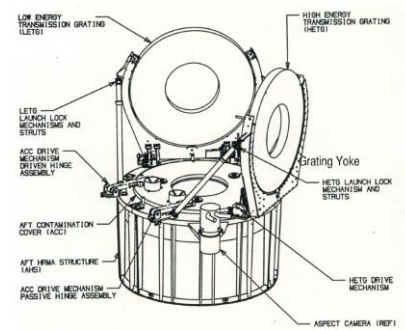

Chandra Heritage Considered

Integrated Science Instrument Module

X-ray Microcalorimeter Designs

Thrust tube design:

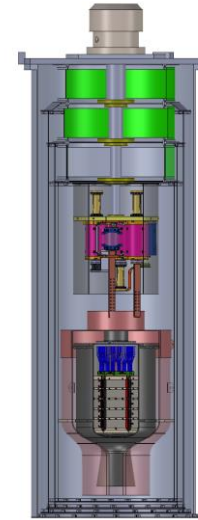

Internal strut design:

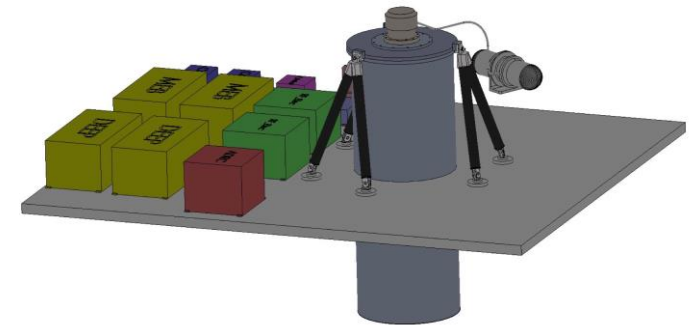
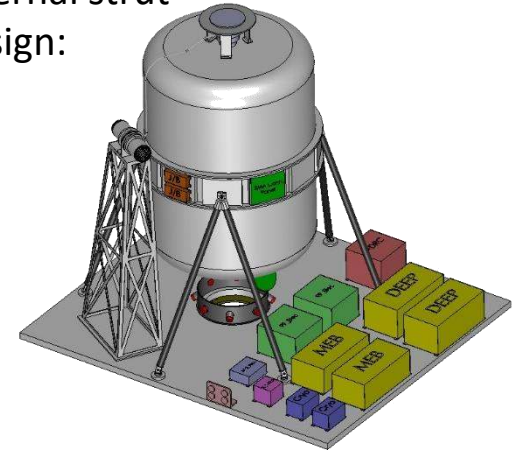

Filter wheel attached to bottom of the cryostat – with sufficient clearance for door

MBSE Output - Examples

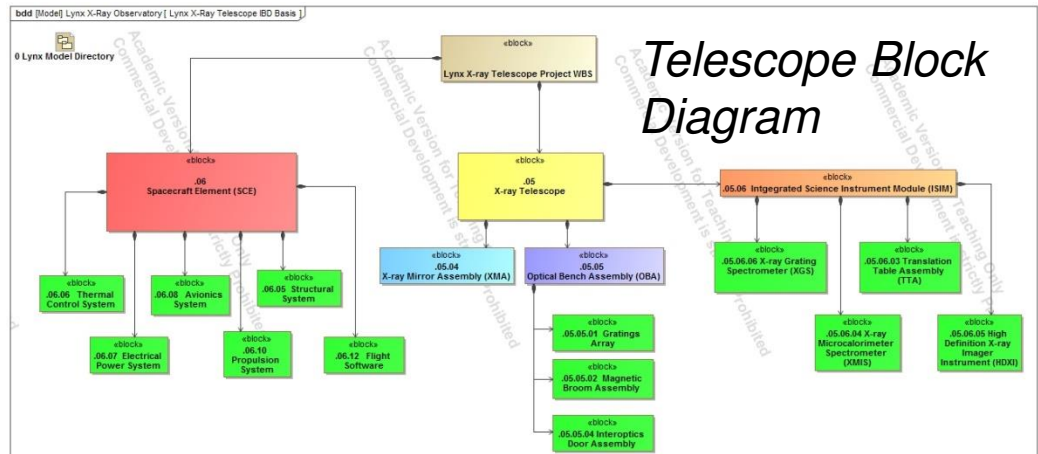

Telescope Functional Diagram

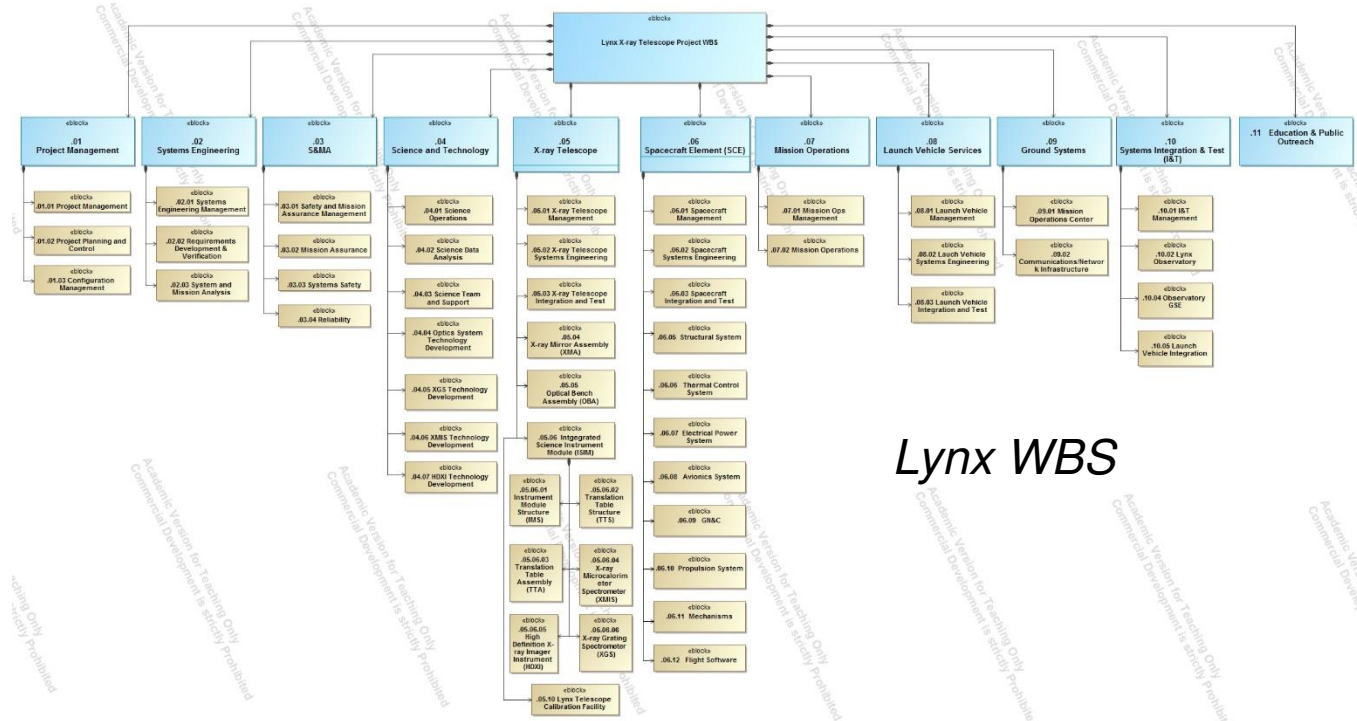
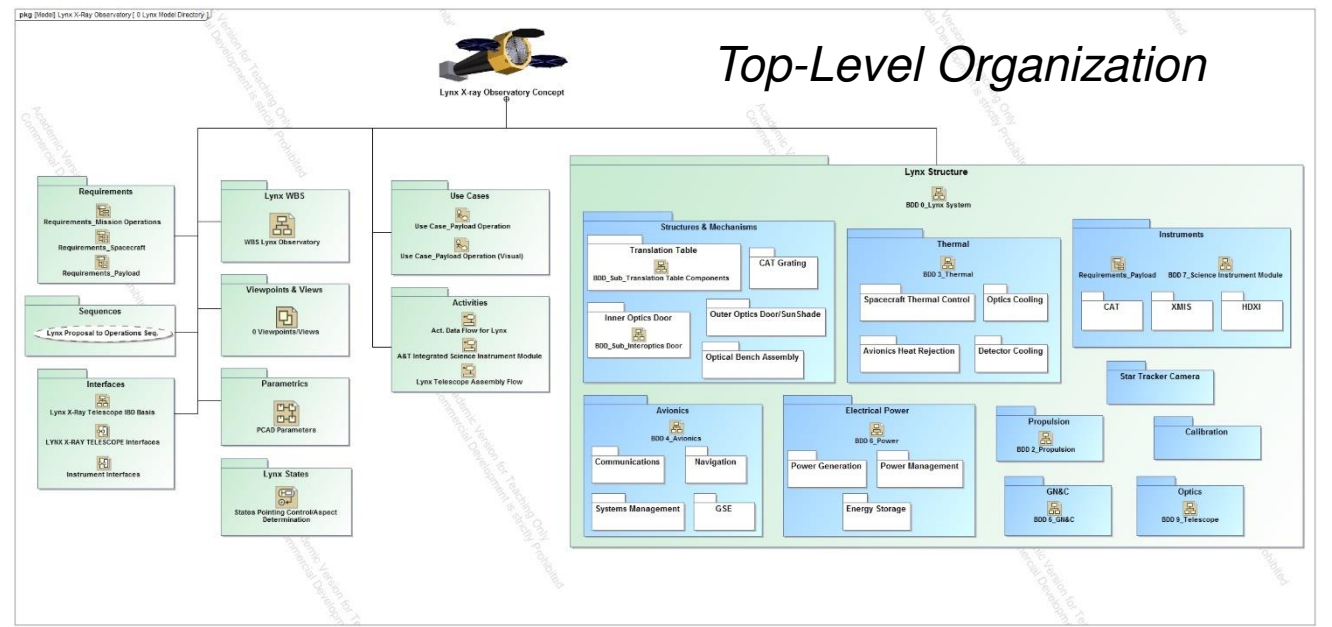
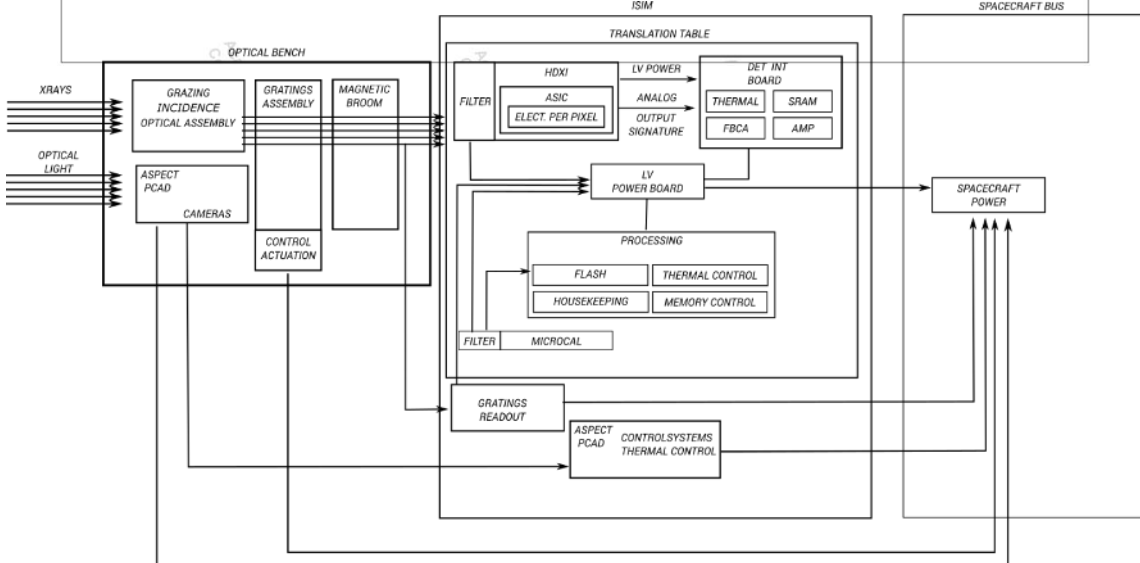

Thank You!

For the latest Lynx news and events, and to sign up to the News Distribution visit us at:

<https://wwwastro.msfc.nasa.gov/lynx/>